

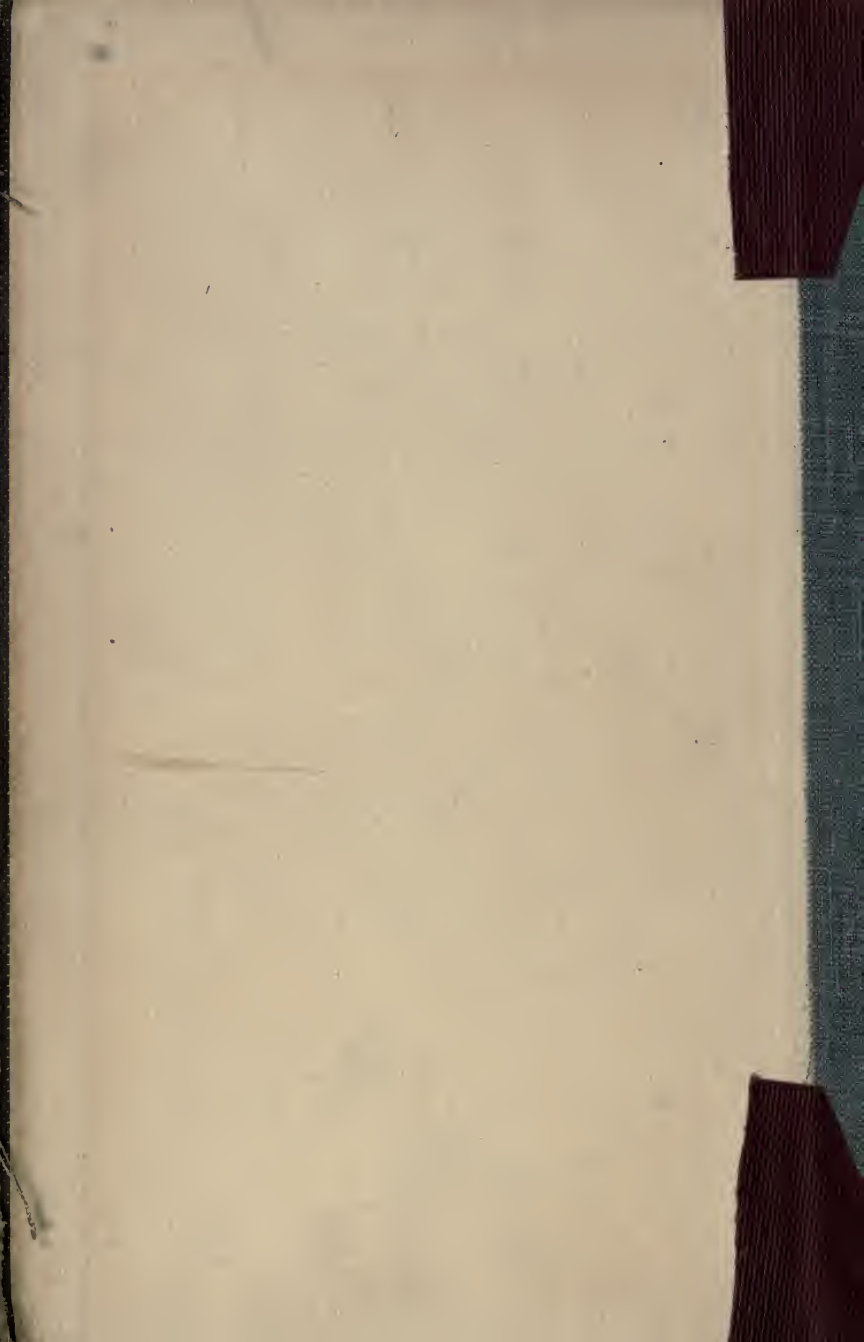

3 1761 05478668 6





Digitized by the Internet Archive
in 2007 with funding from
Microsoft Corporation



ELEMENTARY DYNAMICS

CAMBRIDGE UNIVERSITY PRESS

C. F. CLAY, MANAGER

LONDON : FETTER LANE, E.C. 4



NEW YORK : THE MACMILLAN CO.

BOMBAY
CALCUTTA } MACMILLAN AND CO., LTD.
MADRAS }

TORONTO : THE MACMILLAN CO. OF
CANADA, LTD.

TOKYO : MARUZEN-KABUSHIKI-KAISHA

ALL RIGHTS RESERVED

ysio
leeh.

h.

ELEMENTARY DYNAMICS

A TEXT-BOOK FOR ENGINEERS

BY

Joseph
Hittington
J. W. LANDON, M.A.

FELLOW OF CLARE COLLEGE, AND UNIVERSITY LECTURER
IN MECHANICAL ENGINEERING, CAMBRIDGE

1765/2
30.11.12

CAMBRIDGE
AT THE UNIVERSITY PRESS
1920



2160
11-06

PREFACE

THOSE who have had experience in teaching elementary dynamics to students of Engineering will agree that the majority find considerable difficulty in grasping the fundamental principles on which the subject is based. There are new physical quantities to be understood, and new principles to be accepted which can only be expressed in terms of these quantities. Unfortunately, in many cases, this subject has to be introduced at a stage of development in mathematics at which the student expects some proof of what he is told to believe. He is not so prepared to accept things without proof as he was when first told that $2 \times 3 = 6$. Even at that early stage, probably an attempt was made to prove to him that $2 \times 3 = 6$, yet, in the end, he merely accepted the fact and memorised it.

The author believes that the difficulty experienced is partly, though by no means entirely, due to the way the subject is often presented. In the student's mind it is associated with branches of pure mathematics such as trigonometry, analytical geometry, or infinitesimal calculus, and he is inclined to think that salvation lies in memorising a number of formulae which are to be used in solving problems, instead of looking upon dynamics as a fundamental branch of physical science, in which mathematics is of secondary importance and the physical ideas of primary importance. Quite commonly in elementary text-books, the second law of motion is at first summed up in the form, $\text{force} = \text{mass} \times \text{acceleration}$, and the student is then given a number of examples to work out, most of which consist in substituting numbers in a formula. This very successfully disguises the true meaning of momentum, and the extraordinary generality of the second law of motion. The same applies to problems dealing with motion. The student is generally presented with certain formulae for motion involving a constant acceleration. These formulae, are of

very little, if any, use to him later on, and have merely enabled him to get answers to certain problems without thinking.

At first sight the remedy would appear to lie in teaching dynamics experimentally, but the author's experience is that this is not so for the majority of students. The phenomena of everyday life provide innumerable qualitative experiments, and to most students quantitative laboratory experiments in dynamics are neither interesting nor convincing.

In the following pages an attempt has been made to present the principles of elementary dynamics, and to explain the meaning of the physical quantities involved, partly by definition and description, but mainly by worked examples in which formulae have been avoided as far as possible. By continually having to think of the principle and the physical quantities involved, the student gradually acquires the true meaning of them, and they become real to him.

It will be observed that the first of Newton's Laws of Motion is expressed in a somewhat different form from that in which it is usually given, and the laws are called the Laws of Momentum.

In working examples the absolute unit of force has generally been adopted, and, where applicable, the answers have been reduced to units of weight. It matters little, in the author's opinion, whether absolute or gravitation units are used, so long as mass is not defined as weight divided by the acceleration due to gravity. To say that the engineer's unit of mass is 32.2 lbs. is almost to suggest that he is rather lacking in intelligence, and cannot be expected to understand the difference between equality and proportionality. If weight is introduced in the early conception of mass, the student's conception of mass is extremely vague, and his conception of momentum as a physical quantity is even more vague or erroneous. A student who cannot understand the difference in the two units of force, and who has merely to rely on formulae expressed in one particular set of units, is not likely to get any knowledge of dynamics which will be of real use to him.

A number of graphical examples have been worked out in the text, and a number are included in the examples to be worked by the student. These frequently require more time than analytical examples, but they are more useful and instructive. This is particularly the case with the engineer, who is so frequently faced with problems which can only be solved graphically.

Probably the majority of students will be learning differential and integral calculus at the same time as dynamics, and they should be encouraged to use the calculus in working examples, although all the examples given can be worked without its use.

The examples at the ends of the chapters are arranged more or less to follow the text, and students should work them as they proceed with the reading, and not wait until they have completed the chapter. The miscellaneous examples, at the end of the book, are intended for revision, and for this reason they are not arranged either in order of difficulty or in the order of the chapters dealing with the principles involved. The answers have mostly been obtained by means of a slide rule. It is hoped that the errors in them are not numerous.

Though primarily written for engineering students the book may be useful to some others. The course covered is approximately that required for the Qualifying Examination which Cambridge students have to pass before their second year, if they wish to take an honours degree in Engineering.

The author wishes to thank Mr J. B. Peace, Fellow of Emmanuel College, for valuable suggestions and for having contributed a large number of examples, also Mr W. de L. Winter of Trinity College for very kindly reading the proofs and for useful criticism and suggestions.

J. W. LANDON.

CAMBRIDGE,

August, 1920.

CONTENTS

	PAGE
PREFACE	v
CHAP.	
I. INTRODUCTORY	1
II. MOTION	20
III. LINEAR MOMENTUM	57
IV. ANGULAR MOMENTUM	88
V. CENTRIFUGAL FORCE—CENTRE OF MASS .	110
VI. WORK—POWER—ENERGY	128
VII. UNITS AND DIMENSIONS	162
VIII. SIMPLE HARMONIC MOTION	166
IX. MISCELLANEOUS	187
MISCELLANEOUS EXAMPLES	219
ANSWERS TO EXAMPLES	241
INDEX	245

CHAPTER I

Introductory

THE subject commonly called **Dynamics** is a part of the much bigger subject called **Mechanics**. In its broadest aspect, mechanics deals with bodies or parts of bodies which are acted upon by certain forces, and analyses and examines the effect of these forces in producing motion, or in maintaining a state of rest. For the present purpose mechanics may conveniently be divided into three branches as follows :

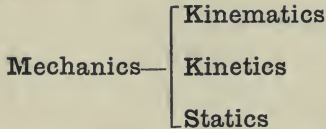

Kinematics is the branch of the subject which deals with the motions of bodies. The bodies may be of any size or shape, and at times it may be convenient to consider them indefinitely small, i.e. as points.

Kinetics deals with the causes of the motions of bodies, and attempts to find a definite relationship between these causes producing or maintaining motion, and the motions themselves.

Statics treats of bodies which are at rest and examines how this state may be maintained.

The subject of *dynamics*, as will be seen, does not in itself form one of the main branches of mechanics, but it may be said generally to include kinetics and a part of kinematics. It deals with motions in so far as they are required in the examination of the forces producing them, and it also deals with the general consideration of the mechanical energy possessed by bodies, either in virtue of their position or of their motion.

Now there are certain fundamental conceptions, and there are also certain principles or laws, which form the basis of the whole subject. Neither the conceptions nor the laws are numerous.

Fundamental Conceptions

These consist of the ideas of **space**, **mass** and **time**. It would be difficult, if not impossible, to define accurately either of these, or to explain exactly how the human mind understands their meaning. The conceptions are acquired in childhood or are born in us. *Space*, *mass*, and *time* are the three fundamental physical quantities, and all the other physical quantities we shall deal with may be defined in terms of them. It is easy to realise that before much practical use can be made of these, we must decide on some unit of measurement of them. We shall here only concern ourselves with two systems of units :

- (1) **Foot, Pound, Second** system. (F.P.S.)
- (2) **Centimetre, Gram, Second** system. (C.G.S.)

Space. We may say that this is what possesses length, breadth and thickness. Each of these is a length and hence space is most conveniently measured in units of length.

In the F.P.S. system the unit of length is the *foot*.

In the C.G.S. system the unit of length is the *centimetre*.

$$1 \text{ foot} = 30.5 \text{ centimetres.}$$

Mass. This may be defined as the quantity of matter or the quantity of stuff in a body. Although it is difficult to define precisely what is meant by mass, we have no difficulty in realising what we understand by the term. If, for example, we ask for half a pound of tobacco, we are not probably interested in the amount of space it occupies, or even its weight, so long as we get the correct quantity of stuff. It may be compressed in the form of a cake and occupy little volume, or it may be loose and occupy a considerable volume. We shall see later how we can compare masses. Probably our earliest conception of mass in childhood is when we try to throw things about. We find that some are more difficult to move or throw than others, and we soon discover that this does not depend upon the size. We consider that

those which are more difficult to throw or move have more stuff in them.

In the F.P.S. system the unit of mass is the *pound* (1 lb.). The standard pound is a particular lump of platinum deposited in the Exchequer Office.

In the c.g.s. system, the unit of mass is the *gram*. Originally this was intended to be the mass of a cubic centimetre of pure water at 4 degrees centigrade, but the standard is now one of platinum like that of the pound.

$$1 \text{ pound} = 453.6 \text{ grams.}$$

In dealing with mass we might conveniently define what is meant by **density**. The density of a substance is the mass per unit volume.

This should not be confused with **specific gravity**. The specific gravity of a substance is the ratio of the mass of a given volume of the substance to the mass of an equal volume of water. For example:

The density of water = 62.3 lbs. per cubic foot.

The specific gravity of steel = 7.78.

$$\begin{aligned} \therefore \text{The density of steel} &= 7.78 \times 62.3 \\ &= 485 \text{ lbs. per cubic foot.} \end{aligned}$$

Time. The unit of time which is adopted in both systems of units is the *second*.

Vectors

The various physical quantities which we have to deal with can be divided into two classes :

- (1) **Scalar** quantities.
- (2) **Vector** quantities.

A **scalar** quantity is one which possesses *magnitude* only, for example, an interval of time, as 3 seconds. There is here no idea

of direction. Again, 2 lbs. of bread. This is merely a definite quantity of stuff and has no connection with direction.

In dealing with scalar quantities we add and subtract by the ordinary rules of arithmetic. For example, in making a certain article in a workshop, work may have to be done on it in three different machines, and the lengths of time in these may be 15 minutes, 40 minutes, and 10 minutes. The total time for machining is then, $(15 + 40 + 10) = 65$ minutes.

A **vector** quantity is one which possesses both *magnitude* and *direction*, for example, the weight of a body. We know that this acts vertically downwards, and that it is generally easier to push an object along than to raise it up.

Suppose we are dealing with the displacement of a body from a given position. Here we want to know, not only how far the body is from its original position, but also in what direction this distance is. Let us take an actual example.

A ship travels 2 miles due east, and then travels $1\frac{1}{2}$ miles in a direction north-east. What is the final displacement of the ship?

The easiest way to solve this is to draw a diagram representing the motion of the ship. Draw OA due east to represent the 2 miles displacement. Make it 1 inch long. Now draw AB in a direction north-east, and make it $\frac{3}{4}$ inch long to represent $1\frac{1}{2}$ miles displacement.

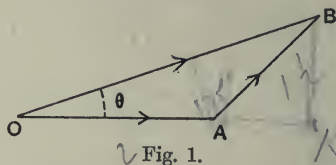

Fig. 1.

The final position of the ship is obviously represented by the point B, and the displacement from the starting-point is given by OB , both in magnitude and direction. By measuring we find OB is 1.62 inches, and we find also that the angle BOA is 19 degrees 9 minutes. We can say, therefore, that the ship is at a distance from the starting-point of 3.24 miles, and that its displacement is 19.15 degrees north of east.

Here we are dealing with vector quantities, since in order to

define them we have to state both magnitude and direction. It is obvious that a vector quantity can conveniently be represented by a straight line, since the line may be drawn of a length to represent the *magnitude* of the quantity, and also be drawn in a definite direction to represent the *direction* of the quantity. In fact, this is why such quantities are called *vector* quantities. A **vector** is a straight line of definite length, drawn in a definite direction. In order to indicate the starting-point of the vector, or to indicate what is called the *sense*, it is often convenient to put an arrow-head on the vector as is shewn in fig. 1.

Addition and Subtraction of Vectors

Suppose we have two vectors as shewn in fig. 2. Let us call them x and y . If we want to find the vector sum of x and y , we take a line OA equal and parallel to x , and then a line AB equal and parallel to y . The sum of the two vectors is given by OB . We write this:

$$\overline{OB} = \overline{OA} + \overline{AB},$$

the line over the top representing the fact that the addition is *vector* addition. The order of the letters gives the sense.

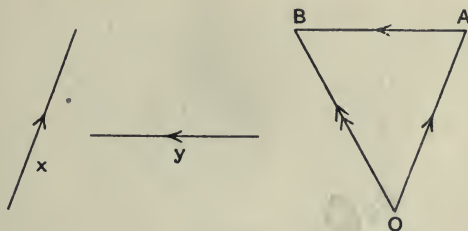

Fig. 2.

If we wish to find the vector difference of x and y we take the line OA as before, and then draw the line AB of the same

length as y , in the same direction, but in the opposite sense as shewn in fig. 3.

We have $\overline{OB'} = \overline{OA} + \overline{AB'} = \overline{OA} - \overline{AB} = \overline{x} - \overline{y}$.

Now in many cases it is convenient to draw the figure accurately to scale, and to measure the vector sum or difference. Sometimes, however, it is more convenient merely to sketch the figure and to calculate the true length and direction of OB or OB' . We shall generally know θ , the angle between the vector quantities we are dealing with.

Draw OM perpendicular to AB as shewn in fig. 4, then

$$\begin{aligned} OB^2 &= OM^2 + MB^2 \\ &= OM^2 + (AB - MA)^2 \\ &= OM^2 + AB^2 - 2AB \cdot MA + MA^2 \\ &= OA^2 + AB^2 - 2AB \cdot OA \cos \theta, \end{aligned}$$

or

$$z^2 = x^2 + y^2 - 2xy \cos \theta.$$

Similarly $OB'^2 = OA^2 + AB'^2 + 2AB' \cdot OA \cos \theta$,

or

$$z'^2 = x^2 + y^2 + 2xy \cos \theta.$$

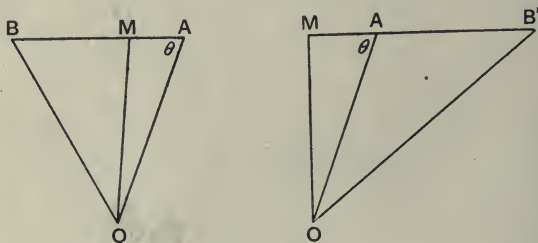

Fig. 4.

The vector OB is called the *resultant* of OA and AB .

The resultant of a number of quantities represents the single

quantity which is exactly equivalent in every way to the number of quantities.

For example in fig. 1, OB is the resultant of OA and AB , and the ship would be in exactly the same position if it had moved 3.24 miles in a direction inclined at an angle 19.15° N. of E., as it is by making the two different movements.

Sometimes we shall find it convenient to think of a single quantity as made up of two quantities. In this case the two quantities are called the **components** of the single resultant quantity.

For example, consider the case of a body being pulled in a certain direction by a pull of magnitude R (see fig. 5). We might produce exactly the same effect on the body by applying two pulls P and Q say. These are then called *components* of the pull R .

If we fix the directions of P and Q , we can at once obtain their magnitudes, by remembering that the vector sum of P and Q must be equal to R .

Let \overline{OB} represent R . From B draw BA parallel to the direction of Q to intersect P .

Then

$$\overline{OB} = \overline{OA} + \overline{AB},$$

$\therefore \overline{OA}$ represents P , and \overline{AB} represents Q .

Now,

$$\frac{P}{R} = \frac{OA}{OB} = \frac{\sin \phi}{\sin (\theta + \phi)}.$$

$$\therefore P = R \frac{\sin \phi}{\sin (\theta + \phi)},$$

and

$$\frac{Q}{R} = \frac{AB}{OB} = \frac{\sin \theta}{\sin (\theta + \phi)}.$$

$$\therefore Q = R \frac{\sin \theta}{\sin (\theta + \phi)}.$$

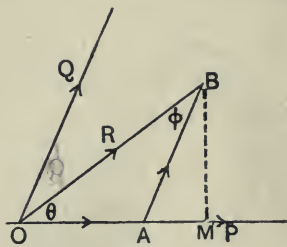

Fig. 5.

Generally we employ *rectangular* components, i.e. components which are at right angles to one another as shewn in fig. 6.

In this case we have

$$\text{Component } AB = OB \sin \theta,$$

$$,, \quad OA = OB \cos \theta.$$

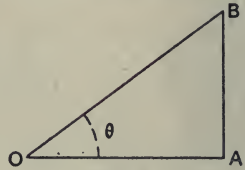

Fig. 6.

There is, however, more advantage in choosing rectangular components than the mere simplification of resolution. If the angle OAB is a right angle, then the components OA and AB represent the *whole* of the quantity OB which is effective in the two directions OA and AB respectively. On the other hand, if the angle OAB is not a right angle, as in fig. 5, then OA and AB are not the whole component of OB in these directions, since component AB has an effect in the direction OA and component OA has an effect in the direction AB . The *whole* component, or *resolved part*, of OB in direction OA is given by OM in fig. 5, where BM is at right angles to OA .

$$\begin{aligned} OM &= OA + AB \cos \widehat{BAM} \\ &= OA + AB \cos (\theta + \phi) \\ &= OA + \text{the rectangular component of } AB \\ &\quad \text{in the direction } OA. \end{aligned}$$

In the case of rectangular components, neither component has any effect in the direction of the other. We shall better realise the importance of this later on when we have dealt with more concrete cases, but we will take one illustration here. Suppose a motor-car is travelling due east, and there is a north-east wind blowing at 20 miles per hour. The north-east wind is equivalent to two winds, one blowing from the north at $20 \times \sin 45^\circ$, i.e. $\frac{20}{\sqrt{2}}$ miles per hour, and one blowing from the east also at $\frac{20}{\sqrt{2}}$ miles per hour. Now the northerly component will have no appreciable effect on the motion of the car, whereas the easterly component will produce a direct resistance to the car's motion.

It may be noted that whereas there is only a single resultant of two quantities, there are an infinite number of pairs of components which will give the same resultant.

This is shewn in fig. 7.

The components (OA_1, A_1B) , (OA_2, A_2B) , (OA_3, A_3B) all have the same resultant OB .

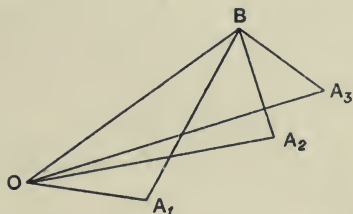

Fig. 7.

Average Values

When we are dealing with two quantities, say y and x , which are related to, or depend upon, one another, we shall at times use the expression, "*the average of one quantity, y say, with respect to the other x .*" Let us make quite sure we understand exactly what we mean.

If we were talking about cricket there would be no need to explain what was meant by the average of a batsman during the season. This is simply the total number of runs made divided by the total number of innings played. Other average values are obtained in a similar way.

Suppose for example we travel by motor-car between two places distant 150 miles and we take $5\frac{1}{2}$ hours to do the journey, we say the average speed was $\frac{150}{5.5}$, i.e. 27.3 miles per hour.

There again we simply take the total value of the one quantity and divide it by the total value of the other quantity.

We must, however, be careful to state what two quantities we are considering. For example, we may state the average cost of an army to the country during a war as so many pounds per day, or we may state the average cost per soldier. The values will be entirely different. In each case we find the total change in one quantity and divide by the total change in the other quantity. We shall have many illustrations of this as we proceed.

Rate of Change

Another idea we have to get hold of clearly is *the rate of change of one quantity with respect to another*.

Suppose for example we have two quantities, denoted by y and x , and that y varies with x in some particular manner. We may express this by giving a table of simultaneous values of the two quantities, as is done in a table of logarithms. Here the two quantities are the numbers x and their logarithms y .

We may also express the variation by representing simultaneous values of the two quantities on a curve as in fig. 8.

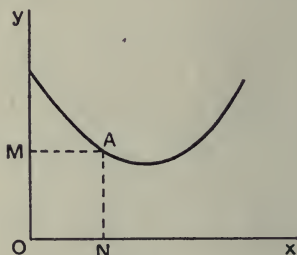

Fig. 8.

For any point A on the curve, ON represents the value of x and NA or OM represents the corresponding value of y .

Frequently we want to know how rapidly one quantity, y say, will change as the other quantity x changes. For example, we may have a motor the speed of which is changing, and we want to know what is the actual speed at different instants of time. This is given us by a speedometer. If a speedometer is not avail-

able, we may get the speed approximately by noting the time taken to travel from one mile-post to the next. This will of course only give us the average speed for the number of minutes required to travel the mile, since the speed of the car may be increasing or decreasing during this time. We should obviously get more nearly what we wanted if we had posts at short intervals of distance, and an accurate stop-watch to measure the time taken between two consecutive posts. If we have a cyclo-meter, we may use this to measure our distances and thereby get still more accurate values of the speed. Now suppose we take the times for different distances from our starting-point, and express the result by a curve as in fig. 9 where y represents the distance from the starting-point and x represents the time taken.

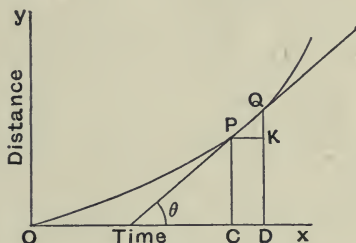

Fig. 9.

To find the speed of the car after a time given by OC we draw CP perpendicular to Ox , then PC is the distance from the starting-point.

Now find the distance from the start when the time has increased by a small amount represented by CD . QD drawn perpendicular to Ox will give the required distance. Draw PK perpendicular to QD . Then the extra distance moved in the small time is given by $QD - PC = QK$.

Let us represent the small change of distance by δs and the small change in time by δt .

Then the average speed for the small interval of time

$$\begin{aligned} &= \frac{\delta s}{\delta t} \\ &= \frac{QK}{PK} \\ &= \tan \widehat{QPK} \\ &= \tan \theta. \end{aligned}$$

Now we shall get nearer to the true value of the speed at P, the smaller we make PK; we shall only get the true value when we take the interval of time indefinitely small. If we do this we can no longer measure QK and PK, but we can still measure $\tan \theta$, because the line joining PQ becomes the tangent to the curve at P, when PK becomes indefinitely small. This is shewn in fig. 10.

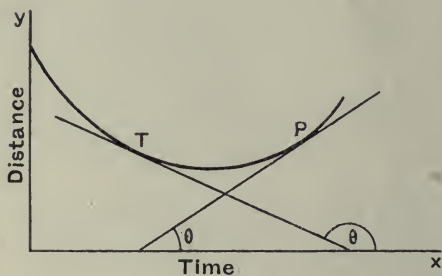

Fig. 10.

Speed at P = $\tan \theta$, i.e. the value of $\frac{\delta s}{\delta t}$ when δt is made indefinitely small.

We write this $\frac{ds}{dt} = \tan \theta$, where $\frac{ds}{dt}$ stands for the rate of change of distance with respect to time.

We have taken a special case, but of course the same holds generally for any quantities x and y and we may write

$$\frac{dy}{dx} = \tan \theta.$$

When θ is greater than one right angle, and less than two right angles, $\tan \theta$ is negative. This means that the rate of change is negative, i.e. y is decreasing as x increases, see point T (fig. 10).

Now in certain cases, instead of accurately drawing the curve to scale we can express the relation between y and x analytically.

In such cases we can also determine the value of $\frac{dy}{dx}$, i.e. the rate of change. This is done for us in the differential calculus.

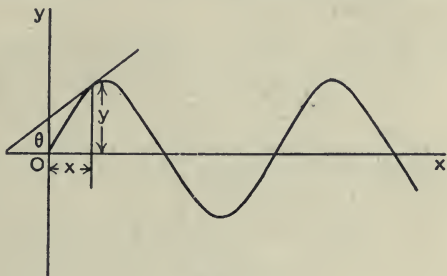

Fig. 11.

We will find the value of the rate of change of y with respect to x for two simple relationships. This will save us a good deal of trouble later on.

(1) Suppose the relation is given by

$$y = a \sin bx.$$

This is shown plotted in fig. 11.

Now we want to find the value of $\frac{dy}{dx}$, i.e. the value of $\tan \theta$ at any point.

We may obtain it thus: Let the radius of the circle in fig. 12 be made equal to a and let the angle AOB be equal to bx . Let, also, the angle BOC be the small angle representing a small increment of x , namely δx , i.e.

$$\widehat{AOB} = bx,$$

$$\widehat{AOC} = b(x + \delta x),$$

$$\therefore \widehat{BOC} = b \cdot \delta x.$$

The value of y corresponding to $x = a \sin bx = BN$.

The value of y corresponding to $(x + \delta x) = a \sin b(x + \delta x) = CM$.

The increase of y for increase of x equal to δx is CK ,

$$\therefore \frac{\delta y}{\delta x} = \frac{CK}{\delta x}.$$

But if \widehat{COB} is very small then the chord CB will be very nearly at right angles to OB , i.e.

$$\begin{aligned} \widehat{CBK} &= \text{complement of } \widehat{KBO} \\ &= \text{complement of } \widehat{BOA}. \end{aligned}$$

$$\begin{aligned} \text{Also } CB &= OB \times \text{angle } COB \\ &= a \times b \cdot \delta x, \end{aligned}$$

$$\begin{aligned} \text{and } CK &= CB \sin \widehat{CBK} \\ &= CB \cos \widehat{BOA} \\ &= a \cdot b \cdot \delta x \cdot \cos bx. \end{aligned}$$

$$\begin{aligned} \therefore \frac{dy}{dx} &= \frac{ab \cdot \delta x \cdot \cos bx}{\delta x} \\ &= ab \cos bx. \end{aligned}$$

Again, suppose that

$$y = a \cos bx.$$

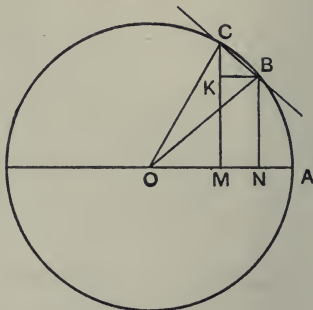

Fig. 12.

Using fig. 12, we have,

Value of y corresponding to x $- a \cos bx = \text{ON}$,
 " " " $(x + \delta x) = a \cos b(x + \delta x) = \text{OM}$.

Increase of y for increase of x equal to δx is $-MN$ (since y really decreases),

$$\therefore \frac{\delta y}{\delta x} = - \frac{MN}{\delta x}.$$

But $MN = KB = CB \cos \widehat{KBC}$
 $= a \cdot b \cdot \delta x \cdot \sin \widehat{BOA}$,
 $\therefore \frac{dy}{dx} = - ab \sin bx$.

We have then, if

$$y = a \sin bx, \quad \frac{dy}{dx} = ab \cos bx,$$

and if

$$y = a \cos bx, \quad \frac{dy}{dx} = - ab \sin bx.$$

Area Curve

In some cases we are given the rate of change of one quantity with respect to another, and we want to find the total effect of this rate of change. For example, we may be given the speed of a body at different instants of time, and want to find how far the body has travelled in different intervals of time. It will be shewn in the next chapter that the distance is given by the area under the curve representing the speed and time. We will now examine a graphical construction which enables the *area curve* to be drawn.

Suppose the given curve is OPQ and we want to find another curve Opq such that the ordinate at any point, say qM , represents the area between the curve OQ and the axis of x . Take any portion of the curve OP and let KL be the mid-ordinate. Draw KK' parallel to Ox and join K' to any point B on Ox produced. Draw Op parallel to BK' , cutting PN at p . Then pN is proportional to the area OPN .

The triangles OpN and BOK' are similar

$$\therefore \frac{pN}{ON} = \frac{OK'}{OB} = \frac{KL}{OB},$$

i.e.

$$pN = \frac{1}{OB} \times KL \cdot ON$$

$$= \frac{1}{OB} (\text{area } OPN),$$

i.e. p is a point on the *area curve*.

For the area under PQ take the mid-ordinate RS . Draw RR' parallel to Ox and join BR' . Draw pq parallel to BR' , and draw pv parallel to Ox .

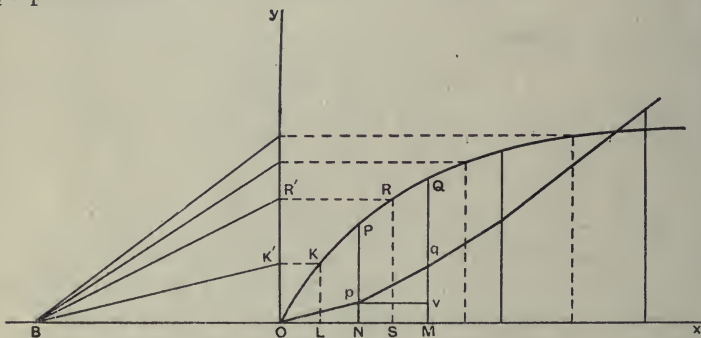

Fig. 13.

The triangles pvq and BOR' are similar,

$$\therefore \frac{vq}{pv} = \frac{OR'}{OB} = \frac{RS}{OB}$$

or

$$vq = \frac{1}{OB} \times (RS \times pv)$$

$$= \frac{1}{OB} (\text{area } NPQM).$$

Hence

$$Mq = pN + vq$$

$$= \frac{1}{OB} (\text{area } OPQM),$$

i.e. q is a point on the *area curve*.

Similarly we may find as many points as we like.

Scales. The scale of the area curve depends upon the distance OB.

Let $OB = h$ inches.

Take 1 square inch of area under the original curve. This, in the area curve, is represented by an ordinate of length $\frac{1}{h}$ inches.

\therefore the scale for ordinates of the area curve is,

$$1 \text{ inch} = h \text{ sq. ins.}$$

Example. A speed-time curve is drawn to the following scales,

$$1 \text{ inch} = 5 \text{ seconds, for the } x \text{ axis,}$$

and, $1 \text{ inch} = 4 \text{ feet per second, for the } y \text{ axis.}$

It is required to find the value of h in inches, so that the scale for the ordinates of the area curve is

$$1 \text{ inch} = 50 \text{ feet.}$$

1 sq. in. under the speed-time curve = 4×5 feet.

\therefore for the ordinates of the area curve we have,

$$h \times 4 \times 5 = 50,$$

or,

$$h = 2\frac{1}{2} \text{ inches.}$$

Examples. Chapter I

1. A sailing boat travels 400 yards in a direction north-east and then 500 yards in a direction 60° west of north. How far has it travelled from the starting-point and in what direction?

If the boat now returns to its starting-point by moving, first due south and then due east, how far will it travel in each of these directions?

2. Three vectors are of magnitude 3, 2, and 1, and their directions are parallel to the sides AB, BC, CA of an equilateral triangle, taken in order. Shew that the resultant vector is perpendicular to the direction of BC, and find its magnitude.

Find also the values of two vectors, one acting in direction AB and the other at right angles to AB, which have the same resultant as the three given vectors.

3. Three wires radiate from a telegraph pole, in a horizontal plane. The first runs east, the second north-east and the third north-west. The tensions in the wires are, respectively, 200 lbs., 150 lbs. and 300 lbs. Calculate the magnitude and direction of the resultant tension. The direction of the resultant is to be specified by the angle it makes with the first wire.

Verify your result by a graphical construction.

4. A vector (r, θ) is a straight line of length r which makes an angle θ with some reference line, the angle being measured in a counter-clockwise direction from the reference line.

If A, B, C represent the vectors $(3, 40^\circ)$, $(5, 115^\circ)$, and $(4.5, 260^\circ)$ respectively, find graphically, (a) $A + B + C$, (b) $A - B$, (c) $B - C - A$.

Check the results analytically by resolving the separate vectors in two directions, along and perpendicular to the reference line.

5. The depth of a trench, measured from the surface of the ground, at different distances along the bottom, is given in the table. Plot a longitudinal section of the trench and estimate the average depth.

Depth in feet ...	3.0	6.2	8.1	6.7	5.1	6.0	5.6	6.0	5.2	4.3
Distance in feet	0	5	24	40	54	60	70	80	92	100

6. A body is moved from rest by a pull P which changes with the distance (s) moved and the time (t) taken, according to the equations

$$P = 80 - 5s, \text{ and } P = 80 \cos \frac{\pi t}{30},$$

the value of P being in pounds when s is measured in feet and t is measured in seconds. Find, graphically, the *space-average* of the pull, and the *time-average* of the pull, for the first 8 feet of motion.

7. The total number of letters collected from a certain district in one year was 854,200. What was the average number of letters collected per day?

If there are 42 post boxes in the district what was the average number of letters posted per week in each box?

8. The population in a certain district at intervals of 5 years was as shewn below.

Plot the figures, and from the graph estimate the population in 1908 and 1917. Find also the rate of increase per year for the same years.

Population in } ... thousands	20·8	29	45·7	71·2	79·3
Year	1900	1905	1910	1915	1920

9. Plot the curve given by $y = 2 \sin \frac{\pi x}{3}$, between the values $x=0$ and $x=3$. Measure the rate of change of y with respect to x for $x=1$ and $x=2\cdot5$. Check your results analytically.

10. Draw the circle $x^2 + y^2 = 4$, and from it find the value of $\frac{dy}{dx}$, (1) for $x=1\cdot5$, (2) for $x = -1\cdot5$.

11. Draw a semicircle with a diameter of 4 inches. Taking one end of the diameter as the origin, and the axis of x along the diameter, draw the area curve.

What is the area under the semi-circular curve from $x=0$, to $x=1\cdot5$?

12. Plot the curve $y = 1\cdot5 \sin \frac{\pi x}{2}$, between the values $x=0$ and $x=4$, and draw the area curve. When the ordinates of the original curve are negative the area is to be considered negative.

13. Plot the curve $y = \frac{x^2}{4}$, between the values $x=0$ and $x=4$, and draw the area curve.

Handwritten notes: $5 = \dots$ and $4 = \dots 368$

$$2x + 2y \cdot \frac{dy}{dx} = 0$$

$$\frac{dy}{dx} = -\frac{2x}{2y}$$

CHAPTER II

MOTION

Speed and velocity

Speed. The meaning of this is quite generally understood. It is merely the rate of travel of a body. For example, if we state that a train is travelling at 25 miles an hour, all we mean is, that if the train continues to run at the same speed it will pass over 25 miles of line in one hour. Here we are not concerned with the direction of travel. The direction may be changing continually, or it may be either in a straight line or along any curved path.

Velocity. The velocity of a body is the rate of change of position and is always measured in a straight line. It is essentially a vector quantity.

Consider a point on the flywheel of an engine. The flywheel may be rotating uniformly at 240 revolutions per minute, and we may say, therefore, that a point on the rim has a constant speed, but we cannot say that it has a constant velocity, in fact, the velocity is continually changing, since its direction is changing, being always tangential to the wheel. This is a very important distinction, as will be seen later.

Velocity may be either **uniform** or **variable**. If a body is moving with a *uniform* velocity then it will pass over equal distances in equal intervals of time, no matter how short the intervals may be, and the distances will all be in the same direction. In the case of a *varying* velocity, the distances passed over in equal intervals of time will be different, or it may be that the directions will be different.

Unit of Velocity. In the F. P. S. system this is 1 foot per second.

In the C. G. S. system the unit is 1 centimetre per second.

If we say that a body is moving with a velocity of 5 feet per second due east, we imply that if it continues for 1 second to have this velocity it will have moved 5 feet due east in the course of the second. If the velocity be varying, then we have two ways of dealing with it :

- (1) We may state the *actual* velocity it has at each instant, or,
- (2) We may state the *average* velocity in respect to time for the interval under consideration.

Let us look at these things graphically.



Fig. 14.

Consider a body K moving in a straight line, and let us start measuring the time when the body is at A.

Now we may represent the position of the body K at any instant by drawing a distance-time curve as shewn in fig. 15. After a time t seconds represented by ON, the distance from A will be given by the ordinate PN, say s feet.

If the body had a uniform velocity it is easy to see that the distance-time curve would be a straight line, since s has to increase uniformly with t .

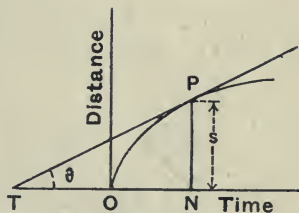

Fig. 15.

It is also evident, in this case, that the velocity will be represented by $\frac{PN}{ON}$, i.e. by $\tan \theta$, (fig. 16).

The velocity-time curve would be a straight line as shewn in fig. 17.

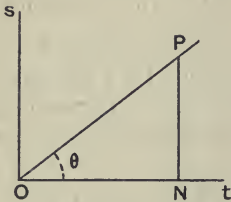

Fig. 16.

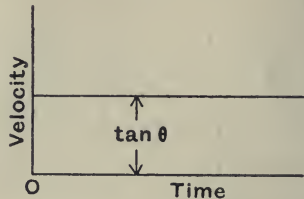

Fig. 17.

Suppose the velocity is varying as shewn in fig. 15, then for any interval of time, t say, we can find the average velocity.

This will merely be $\frac{\text{distance passed over}}{\text{time taken}} = \frac{PN}{ON} = \frac{s}{t}$.

We may want to know the velocity at any particular instant, and this we can find from the space-time curve as follows:

Suppose we require the velocity after a time t , when the distance is given by point P on the curve.

Draw TP the tangent to the curve at the point P ; then the velocity at P will be given by $\tan \hat{PTN}$, i.e. $\tan \theta$.

We have, $\text{velocity} = \frac{ds}{dt} = \tan \theta$.

We may now plot a velocity-time curve, fig. 18, the ordinates of which represent the values of $\tan \theta$ for the space-time curve.

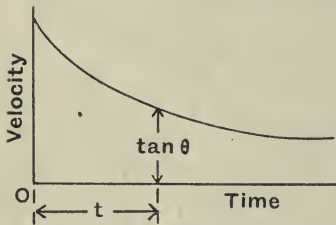

Fig. 18.

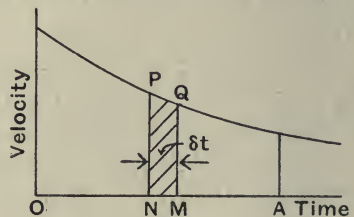

Fig. 19.

Again, we might have been given the velocity-time curve and want to use it to find the distance passed over.

It is easy to see, fig. 19, that for a small interval of time δt , the distance passed over is nearly equal to the velocity at P $\times \delta t$

$$= NP \times MN$$

= area of rectangle PM, approximately.

For the true distance we must take δt indefinitely small.

In this case we cannot draw the rectangle as it becomes a line, but we can clearly see that the sum of the rectangles, for all the small intervals of time from O to A, becomes the area under the curve on the base OA.

Having obtained the distance passed over in any time t by means of the area under the curve, we can now obtain the average velocity with regard to time by dividing this distance by the time.

$$\text{The average velocity} = \frac{\text{area above OA}}{\text{OA}}$$

= the mean height of the curve.

Example (1). *A train has a speed of 60 miles per hour, what is the speed in feet per second?*

60 miles per hour

$$= 60 \times 1760 \times 3 \text{ feet per hour}$$

$$= \frac{60 \times 1760 \times 3}{60 \times 60} \text{ feet per second}$$

$$= 88 \text{ feet per second.}$$

Example (2). *The vanes of a de Laval Steam Turbine are at a mean distance of $3\frac{1}{2}$ inches from the centre of the rotor which runs at 30,000 revolutions per minute. Find the speed of the vanes.*

$$\text{Speed} = 2\pi \times 3.5 \text{ inches in } \frac{1}{30,000} \text{ minute}$$

$$= \frac{2\pi \times 3.5 \times 30,000}{12} \text{ feet per minute}$$

$$= \frac{2\pi \times 3.5 \times 30,000 \times 60}{12 \times 5280} \text{ miles per hour}$$

$$= 625 \text{ miles per hour.}$$

Example (3). A shell is fired at a target 2000 yards away, and explodes at the instant of hitting. At a point distant 1800 yards from the gun and 400 yards from the target, the sounds of firing and exploding of the shell arrive simultaneously. Taking the velocity of sound in air as 1080 feet per second, and assuming the path of the shell straight, find its average velocity.

In fig. 20, let A be the position of the gun, B the position of the target and C the point where the sounds are heard.

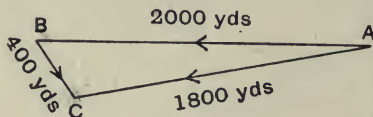

Fig. 20.

Time for sound to travel from A to C = time for shell to travel from A to B + time for sound to travel from B to C.

Let v = the average velocity of the shell in feet per second, then,

$$\frac{1800 \times 3}{1080} = \frac{2000 \times 3}{v} + \frac{400 \times 3}{1080},$$

$$\therefore \frac{2000}{v} = \frac{1400}{1080}$$

or,

$$v = 1542 \text{ feet per second.}$$

Example (4). At a particular instant a body is moving with a velocity of 5 feet per second and 3 seconds later its velocity is 10 feet per second. If it is known that the speed is increasing uniformly with the time, find the distance passed over in the three seconds.

The velocity-time curve is as shewn in fig. 21. It is obvious that the time average of the velocity

$$= \frac{1}{2} (10 + 5) = 7.5 \text{ feet per second.}$$

$$\text{Distance passed over} = 7.5 \times 3$$

$$= 22.5 \text{ feet.}$$

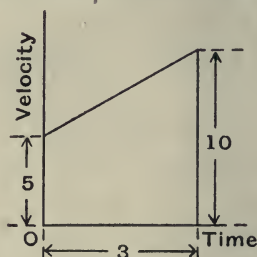

Fig. 21.

Example (5). *The speed-time curve for a motor omnibus, obtained by means of a speed recorder, is given in the following table:*

Speed m.p.h.	6.1	8.1	9.4	10.7	12.8	14.4	15.9	16.8	17.7	18.3	18.7	19.2
Time secs.	2	4	6	8	12	16	20	24	28	32	36	40

It is required to draw the distance-time curve.

The speed-time curve is shown plotted in fig. 22, the scales being:

1 small division = 1 mile per hour,

and

1 small division = 1 second.

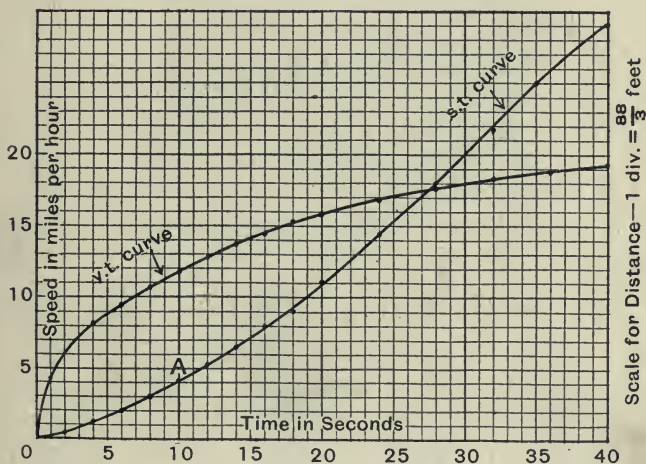

Fig. 22.

The distance passed over is represented by the area under the curve to a scale such that

$$1 \text{ small square} = \frac{88}{30} \times 1 \text{ feet.}$$

Take the distance passed over in the first 10 seconds.

The number of small squares under the velocity-time curve = 82,

$$\text{i.e. distance} = \frac{82 \times 88}{60} \text{ feet.}$$

For the distance scale take

$$1 \text{ small division} = \frac{88}{3} \text{ feet.}$$

The distance for first 10 seconds = 4.1 divisions.

This is shewn by point A.

The distance-time curve obtained in this way is shewn in fig. 22.

If squared paper is not available the graphical method given in chapter I may be used for drawing the area curve.

Referring to fig. 13, p. 16, if we keep the same scales as in fig. 22, we find the distance OB thus.

Let h = the number of small divisions in OB.

The scale for distances is, 1 small division = $h \times \frac{88}{60}$ feet,

$$\therefore h \times \frac{88}{60} = \frac{88}{3},$$

i.e.

$$h = 20 \text{ small divisions.}$$

Example (6). *The supply pipe to a tap is $\frac{3}{8}$ inch bore, and the nozzle of the tap at exit has a bore of $\frac{1}{2}$ inch. The water leaves the tap in a direction inclined at 90 degrees to the supply pipe.*

If the tap discharges 3.6 gallons per minute, what is the velocity of the water at exit, and the change of velocity as it passes through the tap.

1 cubic foot of water contains $6\frac{1}{4}$ gallons.

Let v = the velocity of water at exit in feet per second.

$$\text{The discharge} = \frac{\pi}{16 \times 144} \times v \text{ cubic feet per second}$$

$$= \frac{\pi}{16 \times 144} \times v \times 6.25 \times 60 \text{ gallons per minute.}$$

$$\text{Hence } \frac{\pi}{16 \times 144} \times 6.25 \times 60 \times v = 3.6,$$

or

$$v = \frac{3.6 \times 16 \times 144}{\pi \times 6.25 \times 60}$$

$$= 7.05 \text{ feet per second.}$$

If u = the velocity in the supply pipe, then

$$\frac{\pi \times 9}{4 \times 64 \times 144} \times u \times 6 \cdot 25 \times 60 = 3 \cdot 6,$$

and

$$\begin{aligned} u &= 7 \cdot 05 \times \frac{64}{9} \times \frac{1}{4} \\ &= 12 \cdot 5 \text{ feet per second.} \end{aligned}$$

In fig. 23 let OA represent u and OB represent v , then AB represents the change of velocity, i.e. the velocity which has to be vectorially added to the velocity u to change it to velocity v .

$$\begin{aligned} \text{Change of velocity} &= \sqrt{u^2 + v^2} \\ &= \sqrt{12 \cdot 5^2 + 7 \cdot 05^2} \\ &= \sqrt{205 \cdot 7} \\ &= 14 \cdot 3 \text{ feet per second.} \end{aligned}$$

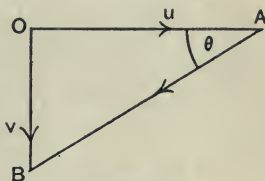

Fig. 23.

The direction is given by the angle θ , i.e.

$$\begin{aligned} \tan^{-1} \frac{v}{u} &= \tan^{-1} \frac{7 \cdot 05}{12 \cdot 5} \\ &= 29 \frac{1}{2}^\circ \text{ (nearly).} \end{aligned}$$

Angular Velocity

When a body is revolving about an axis it is often more convenient to express its speed in terms of the angle turned through in unit time, instead of the distance moved in unit time. The former is called the *angular velocity* of the body and is usually measured in radians per second or revolutions per minute.

It is easy to establish a connection between the angular velocity (ω) and the speed, or velocity (v) at any instant (t). Let a point A rotate about centre O , and let its distance from the

centre be r . Suppose it turns through θ radians in time t and arrives at the point B (fig. 24).

$$\text{Angular velocity} = \omega = \frac{\theta}{t}.$$

$$\text{But speed, } v = \frac{\text{arc AB}}{t} = \frac{r\theta}{t}$$

$$= \omega \cdot r.$$

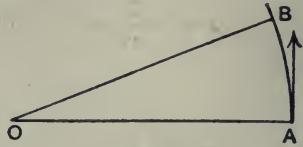

Fig. 24.

Hence the velocity at any instant or the speed $= \omega r$.

Example (7). *The flywheel of an engine is 7 feet in diameter and rotates at 240 revolutions per minute. Find the angular velocity in radians per second, and the linear speed of a point on the rim.*

$$\text{Angular velocity} = 240 \text{ revs. per min.}$$

$$= \frac{240}{60} \text{ revs. per sec.}$$

$$= \frac{240 \times 2\pi}{60} \text{ radians per second}$$

$$= 8\pi \text{ rads. per sec.}$$

$$\text{Speed of a point on the rim} = \omega r$$

$$= 8\pi \times \frac{7}{2}$$

$$= 88 \text{ ft. per sec.}$$

Example (8). *A nut is rotated on a fixed screw at N revolutions per minute. If the screw has n threads per inch and is of effective diameter d inches, find an expression for the speed of sliding of the nut and screw.*

Suppose we strip off one thread and flatten it out, we should get an inclined plane as shewn in fig. 25, where CB equals the circumference of the screw, i.e. πd , and AB equals the pitch of the screw, i.e. $\frac{1}{n}$.

screw, i.e. $\frac{1}{n}$.

Let u = the speed of sliding along AC in feet per minute. We may resolve this into two compounds (a) vertical v_1 , (b) horizontal v_2 .

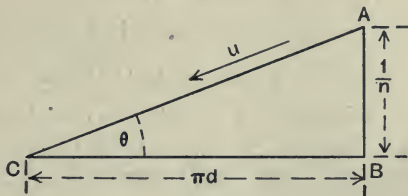

Fig. 25.

In one revolution the horizontal travel is πd inches.

\therefore the horizontal speed = $\pi d N$ inches per minute.

In one revolution the vertical travel equals $\frac{1}{n}$ inches.

\therefore the vertical speed = $\frac{N}{n}$ inches per minute.

The velocity of sliding is equal to the resultant of v_1 and v_2 ,

$$\begin{aligned} &= \sqrt{v_1^2 + v_2^2} \\ &= \sqrt{(\pi d N)^2 + \frac{N^2}{n^2}} \\ &= \frac{N}{n} \times \sqrt{1 + (\pi d n)^2} \text{ inches per minute.} \end{aligned}$$

Acceleration

In precisely the same way as velocity is the rate of change of position, so acceleration is the *rate of change of velocity*: i.e. the change of velocity in unit time. The velocity may be increasing uniformly, in which case we get a constant acceleration. For example, a motor car increased its speed uniformly from

4 miles per hour to 12 miles per hour in 10 seconds. Its acceleration is $(12 - 4)$, i.e. 8 miles per hour in 10 seconds,

$$\begin{aligned} &= \frac{8}{10} \text{ miles per hour in 1 second} \\ &= \frac{8}{10} \times \frac{88}{60} \text{ feet per second in 1 second} \\ &= 1.17 \text{ feet per second per second.} \end{aligned}$$

Again, the velocity may be changing at a variable rate, e.g. in the first second it may increase 1 mile per hour, in the second 4 miles per hour and so on. The acceleration in this case is said to be variable.

It is easy to see that acceleration is related to velocity in exactly the same way as velocity is related to position.

Any properties or formulae which hold for velocity and position will hold also for acceleration and velocity.

Velocity-time curve

Suppose we are given a velocity-time curve as shewn in fig. 26. The acceleration at any time t will be given by the slope of the curve at P, i.e. by the value of $\tan \theta$.

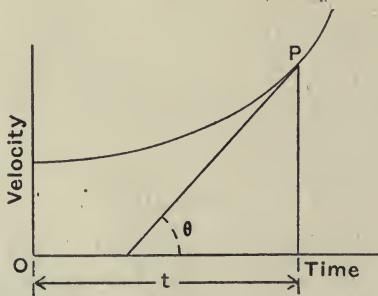

Fig. 26.

Again, if we are given an acceleration-time curve it follows that

the change of velocity in time t is given by the area under the curve from A to P, shewn shaded in fig. 27.

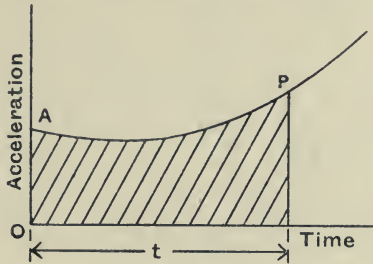

Fig. 27.

Velocity-space curve

In certain practical problems we can obtain the figures for a velocity-space curve and it is often necessary to estimate the acceleration. If v denote the velocity, and t denote the time, the acceleration is given by the value of $\frac{\delta v}{\delta t}$ when δt is indefinitely diminished, i.e. by $\frac{dv}{dt}$. Suppose we wish to find the acceleration at distance s , i.e. at point P on the curve, fig. 28.

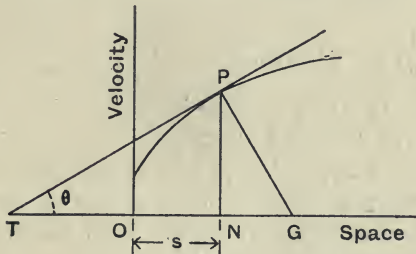

Fig. 28.

Draw the tangent PT to the curve at P , the ordinate PN and the normal PG , i.e. the perpendicular to the tangent.

Now the acceleration = $\frac{\delta v}{\delta s} \cdot \frac{\delta s}{\delta t}$, when δt is indefinitely diminished.

But the limit of $\frac{\delta s}{\delta t} = v$,

and the limit of $\frac{\delta v}{\delta s} = \tan \theta$.

Hence the acceleration = $v \frac{dv}{ds}$
 $= PN \cdot \tan \theta$
 $= PN \cdot \tan \widehat{NPG}$
 $= NG.$

Or, the acceleration is given by the subnormal NG.

$\frac{1}{\text{Velocity}}$, Space curve

Suppose we are given a velocity-space curve and we wish to find the space-time curve.

We have $v = \frac{\delta s}{\delta t}$, nearly,

i.e. $\frac{1}{v} \delta s = \delta t$.

Draw the $\frac{1}{v}$, s , curve (fig. 29).

Then, the time for any distance is given by the area under the curve.

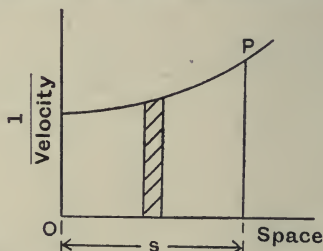

Fig. 29.

In many problems, it is not necessary to actually draw the graphs representing the motion to scale, as we can readily calculate the quantities we require. It is, however, often very helpful to sketch the graph roughly.

Example (9). A tramcar starts from rest and accelerates uniformly for 8 seconds to a speed of 10 miles per hour. It then runs

at a constant speed, and finally is brought to rest in 40 feet with a constant retardation. The total distance passed over is 250 yards. Find the value of the acceleration, the retardation, and the total time taken.

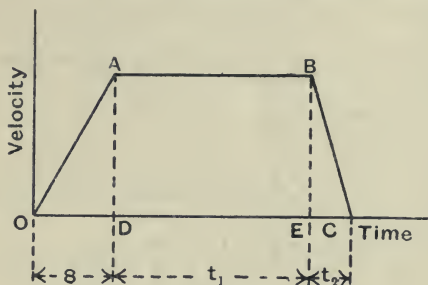

Fig. 30.

The velocity-time curve is shown in fig. 30, where t_1 is the time during which the speed is constant, and t_2 is the time of retardation.

The maximum speed attained = 10 miles per hour
 = $\frac{88}{6}$ feet per second.

Area BEC = the distance passed over during the retardation, i.e.

$$\frac{88}{12} \times t_2 = 40,$$

$$\therefore t_2 = \frac{12 \times 40}{88} = 5.45 \text{ seconds.}$$

Also, area OABC = the total distance passed over, i.e.

$$\frac{88}{12} \times 8 + \frac{88}{6} \times t_1 + 40 = 750.$$

$$\therefore t_1 = \frac{(750 - 40 - 58.7) \times 6}{88}$$

$$= 44.3 \text{ seconds.}$$

We have then,

$$\text{Acceleration} = \frac{88}{6 \times 8} = 1.83 \text{ feet per sec. per sec.}$$

$$\text{Retardation} = \frac{88}{6 \times 5.45} = 2.69 \text{ feet per sec. per sec.}$$

$$\text{Total time taken} = 8 + 44.3 + 5.45$$

$$= 57.8 \text{ seconds.}$$

Example (10). *Using the speed-time curve for the motor omnibus given on p. 25, it is required to construct an acceleration-time curve.*

We have seen that the acceleration at any point P is given by $\tan \hat{PTN}$, where PT is the tangent to the curve at P, fig. 31.

Take the acceleration at 20 seconds from the start,

$$\begin{aligned}\tan \hat{PTN} &= \frac{PN}{NT} \\ &= \frac{11}{37.5} \text{ (measuring in divisions).}\end{aligned}$$

Now each vertical division = 1 mile per hour

$$= \frac{88}{60} \text{ feet per second,}$$

and each horizontal division = 1 second.

Hence to get the true acceleration we have to multiply the value of $\tan \hat{PTN}$ by $\frac{88}{60}$ or $\frac{22}{15}$.

$$\begin{aligned}\therefore \text{acceleration at P} &= \frac{11}{37.5} \times \frac{22}{15} \\ &= 0.43 \text{ ft. per sec. per sec.}\end{aligned}$$

Take for the acceleration scale, 1 small division = 0.1 ft. per sec. per sec., then the acceleration at 20 seconds is given by the point Q.

Repeating this method for times 2, 5, 10, 15, etc. seconds, we get the acceleration-time curve shewn in fig. 31.

Example (11). *A body moves in such a way that its velocity increases uniformly with the distance passed over, and at a distance of 50 feet the velocity is 20 feet per second. What is the acceleration at the instant when the body has moved 15 feet?*

The velocity-space curve is given in fig. 32. PN gives the velocity at 15 feet. Draw PG perpendicular to OP.

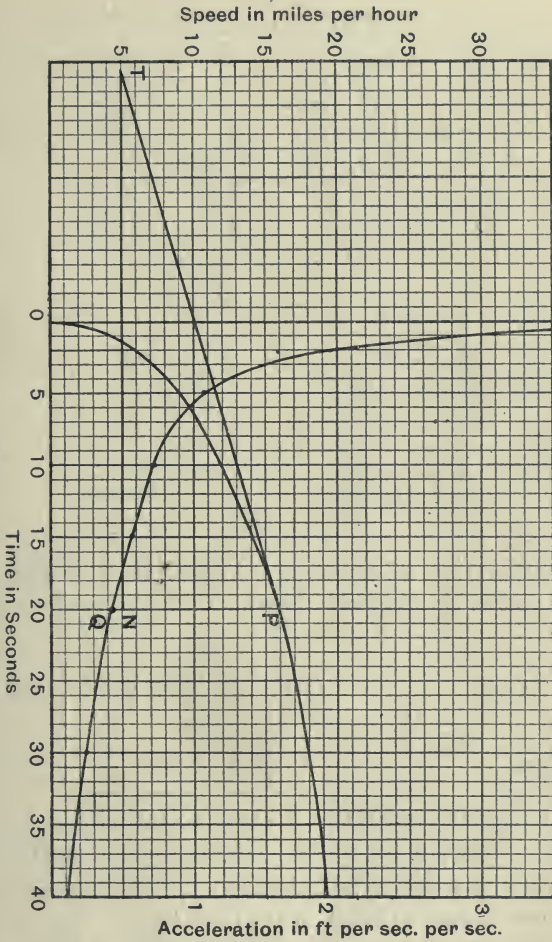

Fig. 31.

The acceleration = NG

$$= PN \tan \hat{NPG}$$

$$= PN \tan \hat{PON}$$

$$= PN \times \frac{PN}{ON}$$

$$= \left(\frac{20 \times 15}{50} \right)^2 \times \frac{1}{15}$$

$$= 2.4 \text{ feet per sec. per sec.}$$

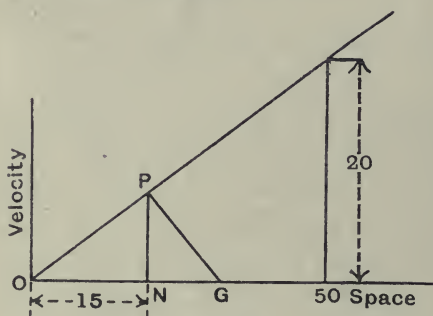

Fig. 32.

Example (12). *The speed of a ship in knots at different distances is given in the table below. Draw the acceleration-space curve, and the speed-time curve.*

Speed (knots)	10.0	12.3	14.1	15.5	16.4	17.0	17.0
Distance (nautical miles)	0	$\frac{1}{4}$	$\frac{1}{2}$	$\frac{3}{4}$	1	$1\frac{1}{4}$	$1\frac{1}{2}$

A nautical mile = 6080 feet, 1 knot = 1 nautical mile per hour.

\therefore 1 knot = 100 feet per minute, approximately.

The velocity-space curve is shown in fig. 33. The acceleration-space curve is shown dotted on the same figure. This is obtained by drawing subnormals. The ordinates are each made equal to twice the subnormals.

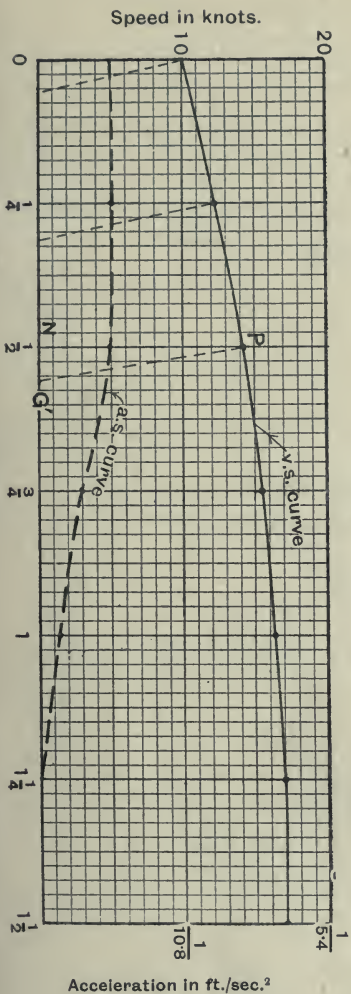

Fig. 33.

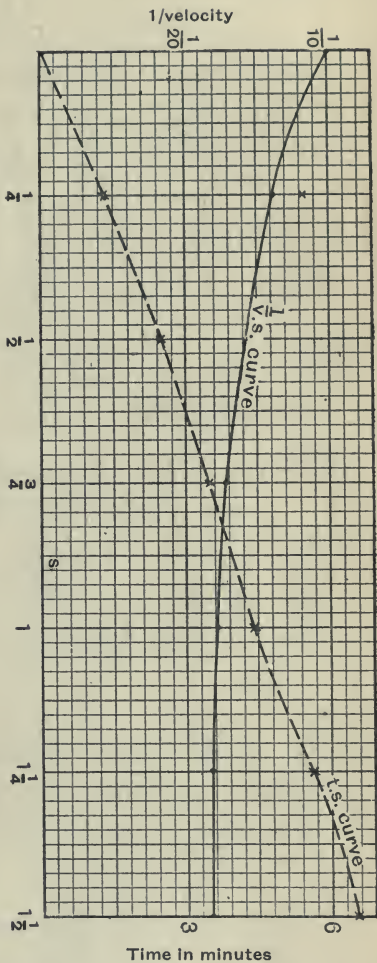

Fig. 34.

Scales : 1 division = 1 knot = $\frac{100}{60}$ feet per second.

1 division = $\frac{1}{40}$ nautical mile = 150 feet.

We saw on p. 31, that the acceleration was given by $v \cdot \frac{dv}{ds}$. If we measure the distances in feet and the velocities in feet per second, the actual length of the subnormal NG in divisions will have to be multiplied by $\frac{100^2}{150 \times 60^2}$, to obtain the true acceleration. Hence the scale for acceleration is

$$\begin{aligned} 1 \text{ division} &= \frac{100^2}{300 \times 60^2} \\ &= \frac{1}{108} \text{ feet per second per second.} \end{aligned}$$

We have seen that the area under the $\frac{1}{v}$, s , curve gives the time. This curve is shown in fig. 34, where the scale for $\frac{1}{v}$ is,

$$1 \text{ division} = \frac{1}{200} \text{ (mile-hour units).}$$

Scale for distance, 1 division = $\frac{1}{40}$ mile.

The dotted line shows the time-distance curve.

This is obtained by plotting as ordinates the area under the $\frac{1}{v}$, s , curve.

The time for distance $\delta s = \frac{1}{v} \delta s$.

Hence, 1 small square = $\frac{1}{200} \times \frac{1}{40}$ hour = $\frac{1}{8000}$ hour.

In the curve drawn, 1 division = 40 small squares

$$\begin{aligned} &= \frac{40}{8000} \text{ hour} \\ &= 18 \text{ seconds.} \end{aligned}$$

Acceleration due to gravity

The number of cases of motion in which the acceleration remains constant are not numerous in Engineering, as in most practical problems we either have a constant velocity or a varying acceleration. One case in which it is usual to assume a constant acceleration is that of a body falling freely. Experiment shews that if the distance from the earth's surface is not large, then the acceleration is nearly constant at any place on the earth. It varies slightly at different points on the earth's surface, but it will be sufficiently near for our purpose to take the acceleration as constant, and equal to 32 feet per second per second, or 981 cms. per second per second. This assumes that the resistance of the air may be neglected, which is only true in the case of quite small velocities. The numerical value of the acceleration is usually denoted by the letter g .

We shall discuss this further when we are dealing with the forces causing motion and the law of gravitation.

Projectiles

We will now work out a few examples on projectiles, making the assumption mentioned above, but it must be borne in mind that the results have very little practical value.

Example (13). *A body is projected with a velocity of u feet per second in a direction inclined at angle θ to the horizontal. It is required to find the total time of flight, the maximum horizontal range, and the maximum height reached.*

Here it is convenient to treat the velocity as consisting of a vertical component and a horizontal component.

$$\text{Horizontal component} = u \cos \theta.$$

$$\text{Vertical component} = u \sin \theta.$$

If we neglect air resistance the horizontal component of the

velocity will remain constant, and the vertical component will decrease uniformly by g feet per second per second.

The path of the body will be as shown in fig. 35 and it is evident that the total time of flight will be twice the time taken to reach the maximum height. The time to reach the maximum height is equal to the time for the vertical velocity to become zero

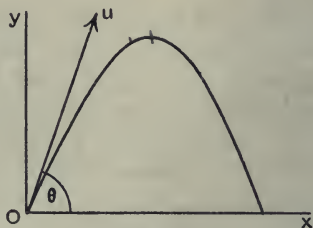

Fig. 35.

$$= \frac{u \sin \theta}{g}$$

$$\therefore \text{the time of flight} = \frac{2u \sin \theta}{g}$$

The range is given by the distance moved horizontally in this time,

$$\frac{u^2 \sin 2\theta}{g} = u \cos \theta \times \frac{2u \sin \theta}{g} = \frac{u^2 \sin 2\theta}{g}$$

This is a maximum when $\sin 2\theta = 1$, i.e. when $\theta = 45^\circ$.

To find the maximum height, we note that since the vertical velocity is decreasing uniformly, the average vertical velocity

$$= \frac{u \sin \theta}{2}$$

\therefore the maximum height

$$= \frac{u \sin \theta}{2} \times \frac{u \sin \theta}{g} = \frac{u^2 \sin^2 \theta}{2g}$$

Path of the Projectile. We can easily find the equation representing the path of the projectile.

Let x = the horizontal displacement at instant of time t from the start. Then

$$x = u \cos \theta \cdot t \dots\dots\dots(1).$$

For the vertical distance,

Velocity at beginning = $u \sin \theta$.

Velocity at end = $(u \sin \theta - gt)$.

Average velocity = $\frac{1}{2}(2u \sin \theta - gt)$.

$\therefore y = \frac{1}{2}(2u \sin \theta - gt) \cdot t,$

or,

$$y = u \sin \theta \cdot t - \frac{1}{2}gt^2 \dots\dots\dots(2).$$

Eliminating t from (1) and (2) we get,

$$y = \frac{u \sin \theta \cdot x}{u \cos \theta} - \frac{g}{2} \frac{x^2}{u^2 \cos^2 \theta},$$

i.e.

$$y = x \cdot \tan \theta - \frac{g}{2u^2 \cos^2 \theta} x^2,$$

which is the equation of a parabola.

Example (14). *A rifle bullet is fired at a target, on the same level as the rifle and distant 900 yards, with a muzzle velocity of 2000 feet per second. Neglecting air resistance, find the angle of elevation. Find also the limits, between the point of firing and the target, within which a man 6 feet high can stand without being hit, assuming the target at the same level as the ground.*

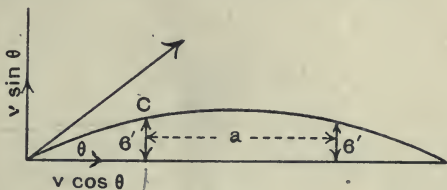

Fig. 36.

Let θ = the angle of elevation, and t = the time of flight.

Horizontally we have

$$2700 = 2000 \cos \theta \cdot t \dots\dots\dots(1).$$

Time to reach the maximum height = $\frac{t}{2}$ seconds.

Retardation upwards = g ft. per sec. per sec.

$$\therefore \frac{2000 \sin \theta}{g} = \frac{t}{2} \dots\dots\dots(2).$$

From (1) and (2), by eliminating t we have,

$$2700 = \frac{2000 \cos \theta \times 4000 \sin \theta}{32},$$

i.e. $\sin 2\theta = \frac{32 \times 2700}{4000000} = 0.0216,$

$$\therefore 2\theta = 1^\circ 14',$$

or $\theta = 37$ minutes.

Let a = the safe zone, and t = the time for the bullet to reach C.

For the vertical motion,

$$6 = \left(\frac{4000 \sin \theta - 32t}{2} \right) \cdot t \dots\dots\dots(3).$$

For the horizontal motion,

$$\frac{2700 - a}{2} = 2000 \cos \theta \cdot t \dots\dots\dots(4).$$

From (3) we get, by substituting for $\sin \theta$ its value 0.0108,

$$6 = 21.6t - 16t^2,$$

or $t = \frac{21.6 - \sqrt{21.6^2 - 24 \times 16}}{32}$

$$= \frac{12.55}{32} \text{ seconds.}$$

From (4) we get

$$2700 - a = \frac{2000 \times 12.55}{32} \times 2.$$

$$\therefore a = 2700 - 1569$$

$$= 1131 \text{ feet.}$$

Change of Direction

In dealing with acceleration, we have up to the present tacitly assumed that the direction of motion remained unchanged, and although dealing with vector quantities we have merely considered the magnitude. We must now consider the case where the direction changes.

Suppose, for example, that a body at a particular instant is moving with velocity u in a direction given by OA (fig. 37) and at t seconds later it is moving with a velocity v and in a direction given by OB . Let us make OA and OB of such lengths that they represent u and v in magnitude. Now in order to change from velocity represented by OA to velocity represented by OB , it is obvious that, we must add vectorially a velocity represented by AB , call it q . Then the average acceleration during the time

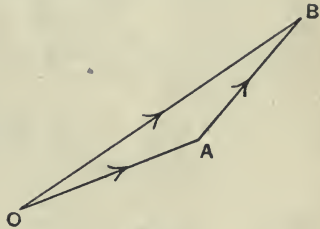

Fig. 37.

$$\begin{aligned}
 &= \text{average rate of change of velocity} \\
 &= \frac{AB}{t} \\
 &= \frac{q}{t}.
 \end{aligned}$$

Circular Motion

Let us apply this to a very common case, viz. that of a body moving in a circular path with a constant speed. Suppose that in time t the body moves from A to B (fig. 38). Draw Oa to represent the velocity at A , and Ob to represent the velocity at B . The added velocity, required to change from velocity v at A to velocity v at B , is given by AB , i.e. the average acceleration for time δt is given by $\frac{ab}{\delta t}$.

But since the triangles Oab and CAB are similar,

$$\frac{ab}{AB} = \frac{Oa}{CA}.$$

$$\therefore \text{the acceleration} = \frac{Oa \cdot AB}{CA \cdot \delta t}.$$

Now

$$\frac{AB}{\delta t} = v.$$

$$\therefore \text{the acceleration} = \frac{v^2}{r}.$$

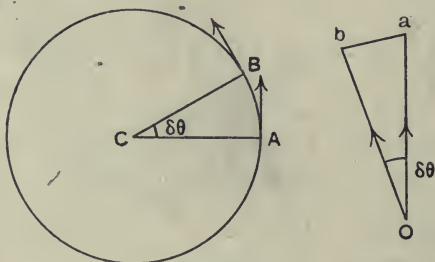

Fig. 38.

When δt is indefinitely diminished $\delta\theta$ becomes zero also, and we see that *the acceleration is always acting towards the centre C and is of magnitude $\frac{v^2}{r}$.*

This is an important result and should be remembered.

Example (15). *A motor-car travelling at 10 miles per hour takes a corner of 10 yards radius. What is the acceleration of the car in feet per second per second?*

$$\text{The speed} = \frac{10 \times 88}{60} \text{ feet per second.}$$

$$\begin{aligned} \text{The acceleration} &= \frac{v^2}{r} \\ &= \frac{10^2 \times 88^2}{60^2} \times \frac{1}{30} \text{ feet per sec. per sec.} \\ &= 7.2 \text{ feet per sec. per sec.} \end{aligned}$$

Example (16). *The crank of an engine has a radius of 9 inches and is rotating at 300 revolutions per minute, what is the linear speed, and the acceleration of the crank pin?*

$$\begin{aligned} \text{The angular velocity} &= \frac{2\pi \times 300}{60} \\ &= 10\pi \text{ radians per second.} \end{aligned}$$

$$\begin{aligned} \text{The linear speed of the crank pin} \\ &= 10\pi \times \frac{9}{12} \\ &= 23.6 \text{ feet per second.} \end{aligned}$$

$$\begin{aligned} \text{The acceleration of the crank pin towards the centre of rotation} \\ &= \frac{23.6^2 \times 12}{9} \\ &= 740 \text{ feet per sec. per sec.} \end{aligned}$$

Relative Velocity

Up to the present, in dealing with motion, it has been assumed that we have some fixed starting point for reference, and that we have measured our displacement from this point. In actual practice, a little thought will shew that we have no really fixed point, but so far as we know any body or point may be moving. It is frequently the case that we imagine a point on the earth's surface as at rest, but in reality this is moving. Again, take the case of an engine on a steamer or motor-car; when we talk about the speed of any moving part of the engine, such as the piston, in estimating its speed we usually imagine the steamer or car at rest. In other words, in dealing with the motion of a body we do not really know anything about the true motion but only the motion relative to some other body which we imagine at rest. Thus all the motions we deal with are really only relative motions. This being so, it will be as well to carefully define what we mean by relative motion. Suppose we have a body or a point A moving relatively to another body or point B, then the relative motion of A with

respect to B is the motion which A appears to have when we view it from B. Take as an example two trains passing one another on parallel tracks. Suppose the train A is moving at 10 miles per hour and the train B at 15 miles per hour. Then to a person in train A viewing train B the latter would appear to be moving with a velocity of $(15 - 10)$ miles per hour, i.e. the relative velocity of B to A is 5 miles per hour. To a person situated in B and viewing A's motion the latter will appear to be $(10 - 15)$, i.e. -5 miles per hour, or the relative velocity is 5 miles per hour in the opposite direction.

Now let us see how we can always measure relative velocity. It is obvious that if we give both bodies the same velocity their relative velocities will be unaltered, e.g. the two trains both have the velocity of the earth, but this does not affect their relative velocities.

Suppose, now, a body A is moving as shewn in fig. 39, with velocity u , a body B is moving with velocity v , and we wish to find the velocity of B relative to A. Give to both bodies a velocity equal and opposite to that of A. This brings A to rest, but does not affect the relative velocity. It is obvious that B's resultant velocity will be the velocity of B relative to A. This is shewn by Bk in fig. 39, where Bn represents the velocity of B, and nk represents the velocity of A reversed. Looking at triangle Bnk , we see that \overline{kn} represents the velocity of point A, and we have

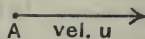
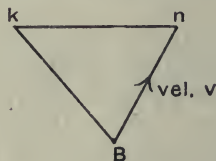

Fig. 39.

$$\overline{Bn} = \overline{kn} + \overline{Bk}.$$

Or remembering that we are dealing with *vectors* :

The velocity of the body B is equal to the velocity of the body A plus the relative velocity of B to A.

Similarly we may state :

The velocity of A is equal to the velocity of B plus the relative velocity of A to B.

Two points rigidly connected. Instead of A and B being two bodies, they may be two points in one rigid body. In this case the relative motion is given in direction, since it must be perpendicular to the line joining the two points. If this were not so, there would be a component of relative velocity along AB, or the points A and B must be either closing in or separating, which is contrary to the assumption that they are rigidly connected. This is shewn in fig. 40.

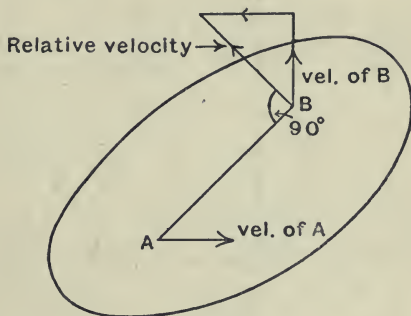

Fig. 40.

Another way of stating this is by saying that the relative motion of B to A is one of rotation of B about A. If ω is the angular velocity of B about A, then the relative velocity of B to A = $\omega \cdot AB$.

Example (17). *The maximum speed of an airship in still air is 40 miles per hour. What is the shortest time in which the ship can travel a distance of 10 miles due north, at a constant altitude, if there is a north-west wind blowing at 18 miles per hour? In what direction will a flag attached to the airship fly?*

The actual velocity of the airship will be equal to the vector sum of the velocity of the wind and the velocity of the ship relative to the wind, i.e. the velocity in still air.

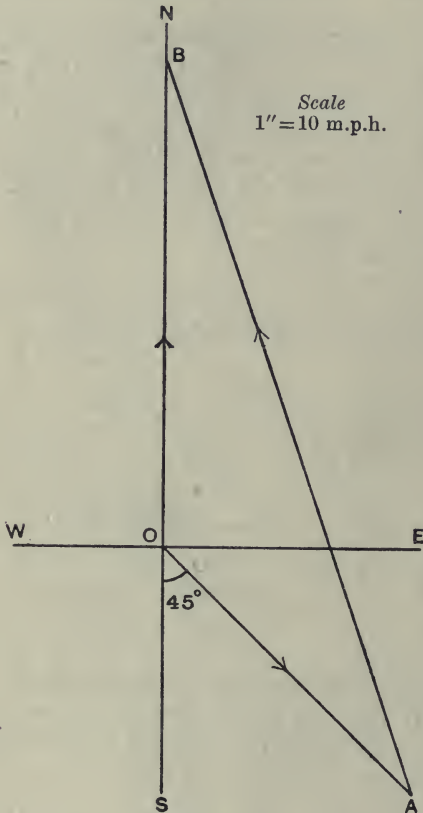

Fig. 41.

Draw OA in a direction south-east to represent to some scale the velocity of the wind (18 miles per hour). Take a length AB to represent, to the same scale, the velocity of the ship in still air. Let this cut the north line through O in the point B .

Then OB represents the actual velocity of the airship.

This by measurement = 25.2 miles per hour.

\therefore The shortest time to travel 10 miles due north.

$$= \frac{10 \times 60}{25.2} \text{ minutes}$$

$$= 23.8 \text{ minutes.}$$

The flag will fly in the direction of the resultant wind on it, that due to its motion with the airship, and the north-west wind.

This is given by the vector sum of BO and OA , i.e. BA .

\therefore The flag flies in the direction BA , which is inclined to the north at an angle of 19° .

Example (18). *The crank of a steam-engine is 9 inches and is rotating at 360 revolutions per minute. The connecting rod is 30 inches long. Find the velocity of the piston when the crank is in the position shewn in the figure below.*

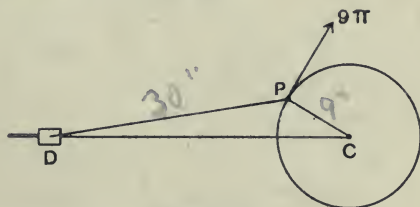

Fig. 42.

In fig. 42, CP represents the crank, PD the connecting rod, and DC the line of stroke. The crosshead D is fixed to the piston and will therefore have the same motion as the piston.

The velocity of $P = \omega r$

$$= \frac{2\pi \times 360}{60} \times \frac{9}{12} \text{ feet per second}$$

$$= 9\pi \text{ feet per second.}$$

Let us give to D and P a velocity equal and opposite to that of P . This brings P to rest and D 's resultant motion will be the

relative velocity of D to P, which must be perpendicular to DP. Draw po to represent a velocity equal and opposite to that of P. Draw od parallel to DC, and pd perpendicular to PD. It is obvious that opd is a triangle of velocities, and that od represents the velocity of D, and pd the velocity of D relative to P.

$$\frac{\text{Velocity of D}}{9\pi} = \frac{od}{op} = \frac{42}{65} \text{ (by measurement),}$$

i.e. the velocity of D = 18.3 feet per second.



Fig. 43.

Rolling wheel

A wheel rolls along a plane, without sliding, at a constant rate; it is required to find the velocity of any point A on the rim.

Let v = the velocity of the centre C, ω = the angular velocity of the wheel, and r = the radius of the wheel.

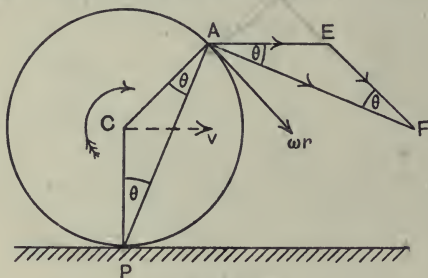

Fig. 44.

For one revolution of the wheel the centre C moves a distance equal to the circumference of the wheel, i.e. the speed of C is the same as the speed of a point on the circumference of the wheel.

$$\therefore v = \omega r.$$

The velocity of A = the vector sum of the velocity of C, and the relative velocity of A to C.

The latter equals ωr and is perpendicular to CA.

In fig. 44 let \overline{AE} represent the velocity of C, and \overline{EF} represent the velocity of A relative to C.

The actual velocity of A is represented by \overline{AF} .

$$\begin{aligned} \therefore \text{The velocity of A} &= 2\omega r \cdot \cos \theta \\ &= \omega \cdot PA. \end{aligned}$$

It is seen from the figure that AF is at right angles to PA.

\therefore The point A is for the instant turning about the point P with an angular velocity ω .

Examples. Chapter II

1. Express the following in metres per second: (1) The speed of a runner who does 100 yards in $10\frac{1}{2}$ seconds. (2) The speed of a train running at 60 miles per hour. (3) The speed of a point on the rim of a flywheel 7 feet in diameter rotating at 250 revolutions per minute.

2. A popular method of estimating the distance away in miles of a flash of lightning is to divide the time in seconds between the flash and the first sound of the accompanying thunder by 5. What velocity of sound in feet per second does this assume?

3. The speed of a ship used to be measured by dropping overboard a log attached to a line and measuring the speed with which the line ran out, it being assumed that the log remained stationary. The line was divided into sections of equal length. Find the length of a section in order that the number of sections running out in 28 seconds should be equal to the speed of the ship in knots.

$$1 \text{ knot} = 6080 \text{ feet per hour.}$$

4. The data for a distance-time curve of a train starting from rest is tabulated below. Plot the curve and from it deduce the speed-time curve.

Distance $\times 10^{-3}$ in feet	0	0.6	2.0	4.4	7.5	11.0	14.8	19.0
Time in minutes	0	1	2	3	4	5	6	7

Distance $\times 10^{-3}$ in feet	23.0	27.8	32.5	37.6	43	48.4	54.2
Time in minutes	8	9	10	11	12	13	14

5. A cam in the form of a circular disc is keyed eccentrically on a horizontal shaft which rotates at 120 revolutions per minute. The diameter of the disc is 6 inches and its centre is one inch from the axis of the shaft. A rod presses against the edge of the disc, and is constrained to move vertically in the plane of the disc along a line passing through the axis of the shaft.

Draw the displacement-time curve of the rod for one revolution of the shaft, and from this curve deduce approximately the velocity-time curve, stating in each case the scales adopted. The end of the rod pressing on the disc may be considered a point.

6. The distance (s) of the piston of an engine from the end of its stroke is given by the equation, $s = 6.5 - 6 \cos 25t - 0.5 \cos 50t$, where s is in feet and t is the time in seconds. Find the velocity at the times given by $t = \frac{1}{32}$ second, $t = \frac{1}{16}$ second, and $t = \frac{1}{8}$ second.

7. A point moves uniformly round a circle of 1 metre radius, making 100 revolutions per minute. Express its linear velocity in feet per second, and its angular velocity in radians per second.

The wheels of a motor-car are 28 inches in diameter. How many revolutions per minute does each wheel make when the car is running at 35 miles per hour?

8. A pulley wheel of 20 inches diameter is connected by a belt to a flywheel of 5 feet diameter, which is rotating at 280 revolutions per minute. What is the speed of the belt if there is no slipping?

Find the speed of rotation of the pulley (1) in revolutions per minute, (2) in radians per second.

9. The spiral grooves in a rifle barrel make one complete turn in 10 inches. Find the speed of rotation of a bullet when it leaves the muzzle with a velocity of 2500 feet per second.

10. A fixed screw of effective diameter 2 inches has 3 threads per inch. A nut on the screw is rotated at 300 revolutions per minute. What is the speed of sliding of the nut in feet per second?

11. At a particular instant a motor car is travelling at a speed of 10 miles per hour, when it starts accelerating at a uniform rate of 2 feet per second per second. Shew that the distance in the 20th second is 53.7 feet.

12. A train starting from rest at one station comes to rest at the next station 6 miles off in 10 minutes, having first a uniform acceleration, then a uniform velocity for 8 minutes and then a uniform retardation; shew that the greatest velocity attained is 40 miles an hour.

13. The table below gives the speeds at different times of an electric train running between two stations. Plot the speed-time curve and from it find the total distance passed over, the mean speed, the initial acceleration, the acceleration at the end of 40 seconds, and the final retardation.

Speed in miles per hour	0	11.2	19.8	28	30	29.2	27	24.8	23.8	21.4	8.5	0
Time in seconds	0	10	20	40	50	60	90	120	130	150	160	166

14. The velocity (v) of the piston of an engine at any time is given by the equation, $v = 10.47 \sin 25t + 0.87 \sin 50t$, where v is in feet per second and t is in seconds. What is the equation giving the acceleration of the piston in terms of the time?

15. The velocity of the ram of a slotting machine for different positions during the cutting and return stroke is given in the table below. Plot the velocity-space curve, and from it deduce the acceleration-space curve.

The length of the stroke is 9 inches.

Fraction of stroke in $\frac{1}{8}$ th	0	1	2	3	4	5	6	7	8
Velocity in ft./sec. Cutting stroke	0	14	21	24	26	27.5	29	29.5	30
Velocity in ft./sec. Return stroke	0	19	32	42	49	55	59	61	62

Fraction of stroke in $\frac{1}{8}$ th	9	10	11	12	13	14	15	16
Velocity in ft./sec. Cutting stroke	29.5	29	27.5	26	24	21	14	0
Velocity in ft./sec. Return stroke	61	59	55	49	42	32	19	0

16. A body moves along a straight path in such a way that its velocity, in feet per second, is related to its displacement, in feet, from a fixed point by the equation, $v^2 = 135 - 60s^2$. Plot the v, s , curve for the complete motion, and from it deduce the acceleration-space curve.

Draw also the space-time curve.

17. A stone is dropped from a balloon which is rising with acceleration a , and t_1 seconds after this a second stone is dropped. Prove that the distance between the stones at a time t after the second stone is dropped is

$$\frac{1}{2}(a+g)t_1(t_1+2t).$$

18. A stone falling freely under gravity is observed to pass from top to bottom of a window 8 feet high in $\frac{1}{8}$ second. Find the distance from the top of the window to the point from which the stone fell.

19. A shell is fired so that at the highest point of its flight it just passes over a mountain half-a-mile high and distant 5 miles from the point of projection. Shew that the horizontal component of the velocity of projection is to the vertical component in the ratio of 5 to 1, and find the values of these components.

20. Water is issuing from a fire-hose nozzle with a speed of 120 feet per second. The jet is to pass through a window which is distant 35 feet vertically and 30 feet horizontally from the nozzle. What must be the inclination of the nozzle if the jet when it reaches the window is (1) to be rising, (2) to be falling?

21. A body at a particular instant was moving due east with a velocity of 5 feet per second, and at a later time it was moving east-north-east with a velocity of 8 feet per second. Find, graphically, the change of velocity in magnitude and direction.

If the time which elapsed between the first and second velocities was 7 seconds, what was the magnitude of the average acceleration during this time?

22. Water is flowing round a small pipe which is bent in an arc of a circle of 18 inches radius, with a speed of 10 feet per second. What is the acceleration of the water while passing round the bend?

23. A cutter can be rowed in still water at 2 knots. It is rowed across a river 400 yards broad, which is flowing at the rate of $1\frac{1}{2}$ knots, starting from one side and reaching the opposite bank 100 yards further up stream. Find the least time in which the passage can be made, and the direction in which the boat will point while going across. Find also the least time and the direction for the return journey.

$$1 \text{ knot} = 6080 \text{ feet per hour.}$$

24. A train A moving with a constant speed of 30 miles per hour is passing another train B which is at rest on a parallel track. At the instant when the engines of the two trains are opposite one another, the train B starts with a

constant acceleration of 2 feet per second per second. What length of time will elapse before the two trains again occupy the same relative position?

If the train B is 100 yards long, at what distance from the station will it just have completely overtaken the train A?

25. Two ships, A and B, start simultaneously from the same point. A steams north-east at 15 knots, and B steams south at 10 knots. Shew that the line AB moves parallel to a fixed direction, and find at what rate the distance AB increases.

After one hour's steaming A changes its course to south; after what time will it be due east of B? At this instant it again changes its course and steams west. At what distance from B will it cross B's course? The distances are to be reckoned in sea miles.

26. Two straight railway tracks, OA and OB, intersect at O and the angle AOB is 60° . A train, P, is running in the direction OA at 40 miles per hour, and another, Q, in the direction OB at 25 miles per hour. Find the magnitude and the direction of the velocity of Q relative to P.

27. A gun pointed at an inclination θ to the horizontal is mounted on a carriage which can run on a horizontal rail. If the shot leaves the gun with a relative velocity v , the gun recoiling along the rail with velocity u , shew how to find the range on a horizontal plane through the point of projection, treating the shot as a projectile *in vacuo*. By how much is the range shortened by the recoil?

If $v=1000$ and $u=10$ feet per second, find whether the range is greater for $\theta=45^\circ$ or $\theta=46^\circ$.

28. The driving wheels of a locomotive are 7 feet in diameter. How many revolutions does each wheel make in a minute when the locomotive is running at 50 miles per hour?

O is the centre of one of the wheels, A its point of contact with the rail, and P a point on the rim. Find the magnitude and direction of the velocity of the point P in each of the positions in which the angle AOP is 120° .

29. A ladder 30 feet long rests with one end on a vertical wall and the other end on the ground at a distance of 12 feet from the wall. The lower end begins to slide horizontally away from the wall with a velocity of 1.5 feet per second. Determine graphically the velocity of the end on the wall, and the relative velocity of the two ends.

30. A cable drum 3 feet in diameter, with side flanges 5 feet in diameter, rests on the road. The free end of the cable, which comes from the under-side of the drum, is pulled forward with a velocity of 2 feet per second. How long will it take to wind up 30 feet of cable, and how far will the drum have rolled during this time?

31. A slider is driven along a straight guide by means of a crank and connecting rod. The length of the crank is 3 inches and the connecting-rod 12 inches. The line of stroke of the slider is 5 inches below the centre of the crank shaft. The crank rotates uniformly at 40 revolutions per minute. Draw a line diagram of the mechanism to a scale $\frac{1}{4}$ full size, and determine the length of stroke, the times of travel of the slider during the forward and return strokes, and the velocity of the slider at the middle of each of the two strokes.

32. The figure below shews two sliders B and C with the same line of stroke BCO. They are driven from the same shaft by means of two cranks OA and OD. If the crank shaft rotates at 75 revolutions per minute, find graphically for the position shewn the relative velocity of B and C.

$$OA = 6'', AB = 12'', OD = 4'', DC = 8''.$$

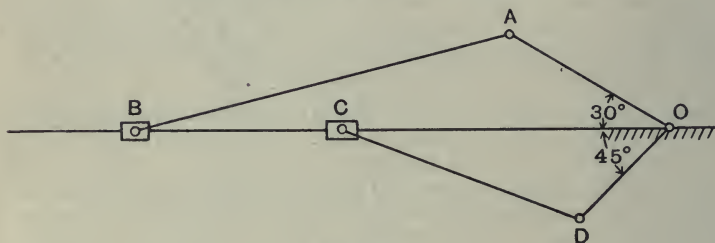

Fig. 45.

CHAPTER III

Linear Momentum

IN the last chapter we dealt with motions, but we did not consider how these motions were produced or changed. We have now to investigate the causes of motion, and for this purpose, we shall use two principles upon which the whole subject of mechanics depends :

- (1) The **Conservation of Momentum.**
- (2) The **Conservation of Energy.**

We will consider the first here, postponing the second for a later chapter. First of all we must introduce, and make ourselves quite familiar with, a new physical quantity, viz. **Momentum**. It is really the product of two physical quantities and we may define it thus :

The Momentum of a body is equal to the product of the mass and the velocity with which it moves.

If a body of mass m lbs. is, at a particular instant, moving with a velocity of v feet per second, then the body is said to possess a quantity of momentum equal to mv ft. lb. sec. units.

Sometimes we shall be considering the change of momentum of a single body, and at others we shall find it convenient to think of the increase or decrease of the resultant momentum of a system, or it may be the component of momentum in any particular direction. Since velocity is a vector quantity so momentum must be considered a *vector quantity*, the direction being that of the velocity.

The quantity of momentum of a body or system may be changed in various ways :

- (1) The mass may remain constant and the velocity be changed in magnitude, e.g. a train moving along a *straight* track may increase or decrease its velocity.

(2) The mass may remain constant and the velocity be changed in direction without any change in magnitude, e.g. the speed of the train may keep constant, but the direction may be changed.

(3) The mass may be changing with the velocity remaining constant, e.g. a locomotive picking up water from a trough along the track.

(4) Any combination of the above three, e.g. a rocket when fired. Here the mass is changing as the products of combustion are blown out, and also the velocity may be changing both in magnitude and direction.

We will now state the laws or principles of momentum*.

1st Law. In any body or system the total momentum remains constant unless the body or system is acted upon by some external force.

2nd Law. If there is a change of momentum, then the force producing it is proportional to the rate of change of momentum and acts in the same direction.

The *first* law introduces a new term, viz. **Force**, which may for the present be defined thus :

Force is that which produces or tends to produce a change of momentum.

The law is the result of observation. If the momentum of a body changes we immediately look for some cause, and this cause we call force. For example, in cycling we may find that our velocity has increased in magnitude, or our direction of motion may be changed, and we immediately look for some cause. It may be that a wind has sprung up and is exerting a force in the direction of motion, thus increasing our velocity, or it may be that we have met an obstacle in the form of a stone with the result that a side force has been exerted and this has changed our direction.

The *second* law is really based upon experimental observation,

* See Preface.

and provides a means of measuring the force which is producing a change of momentum.

Let us make the matter clear by taking a simple concrete case. Suppose we have a mass M acted upon by a constant force F , and that this force, during a time t , produces an increase of velocity from v_1 to v_2 .



Fig. 46.

The momentum at the beginning of the time = Mv_1 .

The momentum at the end of the time = Mv_2 .

∴ the change of momentum = $Mv_2 - Mv_1$.

From the 2nd law,

$$F \propto \frac{Mv_2 - Mv_1}{t}$$

∴ we may write,

$$\begin{aligned} F &= k \cdot \left(\frac{Mv_2 - Mv_1}{t} \right) \\ &= k \cdot \frac{M(v_2 - v_1)}{t} \dots\dots\dots(a), \end{aligned}$$

where k is a *constant*, the value of which depends upon the units which we adopt for measuring the force.

Absolute System of Units

The unit force is that force which produces unit change of momentum in unit time.

Taking $M = 1$, $v_2 - v_1 = 1$, and $t = 1$, we have,

$$1 = k \cdot \frac{1 \cdot 1}{1}, \text{ i.e. } k = 1.$$

Hence with this unit we may write,

$$F = \frac{M(v_2 - v_1)}{t},$$

or, the force is equal to the change of momentum in unit time.

In the F.P.S. system the absolute unit of force is often called the **Poundal**, and is that force which acting on a mass of 1 lb. produces a change of velocity of 1 foot per second in one second.

In the C.G.S. system the absolute unit of force is called the **Dyne**, and is that force which acting on a mass of 1 gram produces a change of velocity of 1 centimetre per second in one second.

Gravitation Units

Newton discovered that any two masses attract one another with a force which varies directly as the product of the masses, and inversely as the square of the distance between them.

Thus, there is a force acting between every body and the earth and this force is called the *force due to gravity*. For any particular body, this force is not really constant except for a definite position, but near the earth's surface the variation is so small that it may be neglected. The force due to gravity on a body is called the **weight** of the body.

We may take the unit weight, i.e. the force of gravity on unit mass, to be our unit of force. This, as noted before, will not strictly be constant unless we specify a definite position or place on the earth's surface. The position is generally stated to be at Greenwich, where the value of the acceleration of a freely falling body is 32.19 feet per second per second, or 981 cms. per second per second.

Denote the numerical value of this acceleration by g .

If we have M lbs. of mass falling freely the acceleration is g feet per second per second, i.e. in unit time there is a change of velocity equal to g , and therefore a change of momentum Mg units.

The force acting is M lbs. wt.

From (a) above, we have :

$$M = k \cdot M \cdot g.$$

$$\therefore k = \frac{1}{g}.$$

Hence with this unit we write,

$$F = \frac{M(v_2 - v_1)}{g \cdot t},$$

or, *Force equals the change of momentum per unit time divided by g.*

In what follows we shall generally use the *absolute unit of force* when working problems, and if necessary, we can express the forces at the end in terms of weight.

It is obvious that :

The absolute unit of force

$$= \frac{1}{g} \{\text{Units of weight}\},$$

or 1 lb. wt. = 32 pounds,

and 1 gram wt. = 981 dynes.

It is very important to distinguish between **mass** and **weight**.

As we have previously stated, *mass* is merely the quantity of matter, and is a *scalar* quantity ; *weight*, on the other hand, is a *force*, and is a *vector* quantity (its direction being always towards the centre of mass of the earth).

We are often, in problems, given the weight of a body, when what we really want is the mass. This is due to the fact that the commonest way of comparing masses is by weighing. Since in any one place the rate of change of velocity due to gravity is constant, it follows that the force due to gravity will only vary with the mass. If we use gravitation units for force, the weight and mass are numerically equal, but it must not be forgotten that they are two entirely different physical quantities. The *mass* of a body is constant no matter where the body may be, but on the other hand, the *weight* will vary with the distance of the body from the centre of the earth.

Suppose, for example, we use a spring balance for measuring our weight, and that this spring balance is calibrated at the equator. Here using foot, second units,

$$g = 32.091.$$

Now suppose we use the spring balance to weigh stuff at one of the poles. Here

$$g = 32.252.$$

The spring balance requires the same force to produce a definite reading wherever it may be, hence for the same weight, the quantities of stuff at the equator and poles will be in the ratio of 32.252 : 32.091,

i.e. we shall measure $\frac{32.252 - 32.091}{32.091} \times 100$ per cent., or $\frac{1}{2}$ per cent. more stuff at the equator than we do at the poles.

Example (1). *A cage weighing $2\frac{1}{2}$ tons is raised and lowered in a coal mine shaft by a steel cable. Find the tension in the cable,*

- (1) *When the cage is raised or lowered with a constant velocity,*
- (2) *When the cage is lowered with the speed increasing uniformly from 0 to 1000 feet per minute, in the first 50 feet.*

Let T be the tension in the cable in poundals, just above the cage. Then the resultant force acting on the cage is,

$$(T - 2.5 \times 2240 \times g) \text{ pdls.}$$

(1) If the velocity is constant, there is no change of momentum.

$$\therefore T - 2.5 \times 2240 \times g = 0,$$

or $T = 2\frac{1}{2}$ tons wt.

- (2) The resultant force downwards
 $= (2.5 \times 2240 \times g - T) \text{ pdls.}$

The average velocity = 500 feet per minute.

\therefore The time to move 50 feet = $\frac{1}{10}$ minute.



$2.5 \times 2240 \times g \text{ pdls}$

Fig. 47.

The change of momentum downwards per second

$$= \frac{2.5 \times 2240 \times 1000}{\frac{1}{16} \times 60 \times 60}.$$

From the 2nd Law,

$$2.5 \times 2240 \times g - T = \frac{2.5 \times 2240 \times 10000}{60 \times 60},$$

or

$$T = 2.5 \times 2240 (32 - 2.8) \text{ pdls.}$$

$$= \frac{2.5 \times 2240 \times 29.2}{32} \text{ lbs. wt.}$$

$$= 2.28 \text{ tons wt.}$$

Example (2). A train weighing 300 tons is being pulled up an incline of 1 in 150 by an engine which is exerting a pull in the coupling of 15 tons wt. If the tractive resistance is constant and equal to $\frac{1}{40}$ of the weight, find the acceleration in feet per second per second.

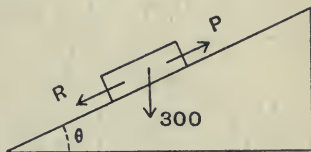

Fig. 48.

Let R be the resistance in tons wt. and P be the pull in the coupling in tons wt.

The resultant force up the incline = $(P - R - 300 \sin \theta)$ tons wt.

$$\tan \theta = \frac{1}{150},$$

$$\therefore \sin \theta = \frac{\tan \theta}{\sqrt{1 + \tan^2 \theta}} = \frac{1}{150} \text{ (nearly).}$$

If a = the change of velocity per second, i.e. the acceleration, in feet per second per second

$$(P - R - \frac{300}{150})g = 300 \times a,$$

$$\therefore a = \frac{(15 - \frac{300}{40} - 2) \times 32}{300}$$

$$= \frac{5.5 \times 32}{300}$$

$$= 0.585 \text{ ft. per sec. per sec.}$$

Example (3). *In the arrangement shewn in fig. 49 below, the mass of the pulleys and friction may be neglected, and the string may be taken as inextensible.*

Find the ratio of $\frac{M}{m}$ in order that M may ascend with a constant acceleration of 2 feet per second per second.

The forces, in absolute units, acting on the masses are shewn on fig. 49.

Consider each of the masses separately.

Take mass M. The resultant force acting upwards in the direction of the acceleration = $T_1 - Mg$,

$$\therefore T_1 - Mg = Ma \dots\dots\dots(1).$$

For mass m, we have

$$mg - T_3 = M\beta \dots\dots\dots(2).$$

Also, since no resultant force is required to accelerate the pulleys we have,

$$T_1 = 2T_2,$$

and

$$T_2 = T_3.$$

Now imagine M raised 1 foot, then if the string remains taut, m must be lowered 2 feet, and we get:

$$\beta = 2a.$$

Substituting in (1) and (2), we have:

$$2T_2 - Mg = Ma,$$

and

$$mg - T_2 = 2ma.$$

Eliminating T_2 we get,

$$(2m - M)g = (M + 4m)a.$$

$g = 32$ ft. per sec., and $a = 2$ ft. per sec. per sec.,

$$\therefore (2m - M)16 = M + 4m,$$

or

$$17M = 28m,$$

i.e.

$$\frac{M}{m} = \frac{28}{17}.$$

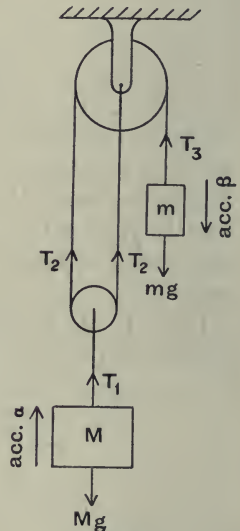

Fig. 49.

Example (4). *Clay is raised from a pit in a truck which is wound up an incline of 1 in 10. The winding engine is such that the pull in the rope is kept constant and equal to 550 lbs. wt. The weight of the loaded truck is 2 tons and the total resistance is equal to 40 lbs. per ton.*

Find the velocity of the truck after it has moved from rest up a distance of 50 feet measured along the incline.

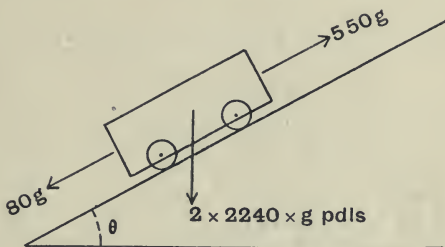

Fig. 50.

$$\tan \theta = \frac{1}{10},$$

$$\therefore \sin \theta = \frac{1}{\sqrt{101}} = \frac{1}{10} \text{ nearly.}$$

The resultant force up the track

$$\begin{aligned} &= 550g - 80g - 4480 \sin \theta . g \\ &= (550 - 80 - 448) g \\ &= 22 \times g \text{ pdls.} \end{aligned}$$

Let v = the velocity gained in time t .

Then by the 2nd law of momentum,

$$22g = 2 \times 2240 \times \frac{v}{t},$$

i.e.

$$\frac{v}{t} = \frac{22 \times 32}{2 \times 2240},$$

or,

$$\frac{v}{t} = \frac{11}{70} \dots\dots\dots(1).$$

The gain of velocity will be uniform, since the force applied is constant, and therefore the average velocity = $\frac{v}{2}$.

Hence
$$\frac{v}{2} \times t = 50,$$

and from (1)
$$\frac{v^2}{2} = \frac{550}{70}.$$

$$\begin{aligned} \therefore v &= \sqrt{\frac{110}{7}} \\ &= 3.95 \text{ feet per second.} \end{aligned}$$

Varying Force

In order to derive our units we have, up to the present, assumed a constant force and a constant mass, but in many cases the force will not be constant and the momentum may be changing in various ways. Suppose the force is varying with the time in the manner shewn in fig. 51. Here we can either measure the rate of change of

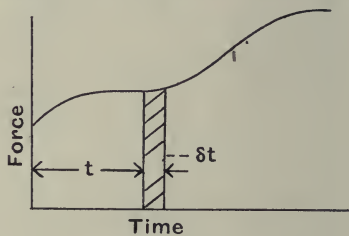

Fig. 51.

momentum at definite instants of time, or, we can find the total change of momentum for a definite interval of time.

Let $\delta(mv)$ be a small change of momentum produced in time δt starting at time t . Thus for this interval of time we have the time average of the force equal to $\frac{\delta(mv)}{\delta t}$, and the true force at

time t is the value of $\frac{\delta(mv)}{\delta t}$ when δt is indefinitely diminished,

i.e.
$$F = \frac{d(mv)}{dt},$$

or if m is constant,
$$F = m \frac{dv}{dt} = ma,$$

where a = the acceleration at the particular instant of time t .

Again we have

$$F = \frac{\delta(mv)}{\delta t} \text{ nearly,}$$

or $F \cdot \delta t = \delta(mv).$

For any time T we may find the sum of each of these terms.

We get $\Sigma F \delta t = \Sigma \delta(mv).$

Now $\Sigma F \delta t$, when δt is made indefinitely small, is represented by the area under the force-time curve from $t=0$ to $t=T$, and this area, therefore, represents the total change of momentum produced by the varying force.

Suppose we find the value of $\frac{\Sigma F \delta t}{T}$. This obviously gives us the time average of the force. Let us call it F' .

Then, $F' \cdot T =$ the total change of momentum.

We must now see how these laws are applied to practical problems, and chiefly we shall deal here with the second law, which we will re-write in this form:

Force in Absolute units

= Change of momentum in unit time.

Accelerating Force on a Piston

Take the case of a petrol engine. Suppose we wish to find the thrust in the connecting rod for a given position of the crank. Let $P =$ the total force in lbs. wt. due to the gases on the piston for the position considered.

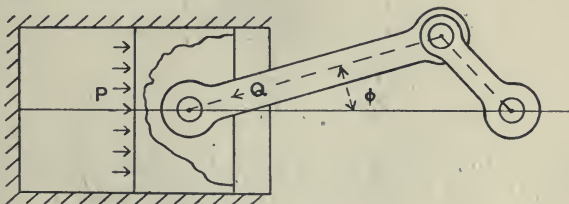

Fig. 52.

In example (18), p. 49, we have seen how the velocity of the piston may be found, and we can therefore draw a velocity-space curve. From this curve we can construct an acceleration-space curve. Let a be the acceleration, measured towards the crank shaft of the piston, in the given position. Let Q = the reaction, in lbs. wt., of the connecting rod on the gudgeon pin. Consider the motion of the piston. The resultant force in the direction of the motion

$$= (P - Q \cos \phi) g \text{ pdls.}$$

This must equal the rate of change of momentum.

$$\therefore (P - Q \cos \phi) g = Ma,$$

where M is the mass of the piston and gudgeon pin in lbs.,

i.e.
$$Q = \left\{ P - \frac{Ma}{g} \right\} \frac{1}{\cos \phi} \text{ lbs. wt.}$$

To get some idea of the possible magnitude of the quantities involved, take the following example.

Example (5). *In a particular engine the mass of the piston and gudgeon pin is 5 lbs. When the engine is running at 1500 revolutions per minute the acceleration at the beginning of the working stroke is 7500 feet per second per second. The diameter of the cylinder is 4 inches, and the pressure at the beginning of the stroke is 300 lbs. per square inch.*

To find the value of Q at the beginning of the stroke we have

$$P = \pi \times 4 \times 300 \text{ lbs. wt.}$$

$$\cos \phi = 1.$$

$$\therefore Q = \left\{ 1200\pi - \frac{5 \times 7500}{32} \right\} \text{ lbs. wt.}$$

$$= 3768 - 1172$$

$$= 2596 \text{ lbs. wt.}$$

Example (6). *In starting a train, the engine driver opens the throttle so that the tractive force increases uniformly from zero to 7 tons wt. during the first 20 seconds. The total weight of the train*

is 400 tons, and the resistance at starting increases up to 17 lbs. a ton, and then remains constant for the remainder of the 20 seconds.

Find the instant the train starts to move, and draw a velocity-time curve for the time considered.

Let P = the tractive force, and R = the maximum tractive resistance. The train will start when $P = R$.

In fig. 53, OAB represents the tractive force-time curve and OAC represents the tractive resistance-time curve.

The maximum value of $R = AN$

$$= \frac{17 \times 400}{2240} \text{ tons wt.}$$

$$= 3.04 \text{ tons wt.}$$

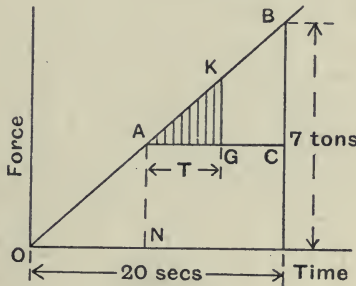

Fig. 53.

The time at which the train begins to move is given by ON

$$= \frac{3.04}{7} \times 20 \text{ seconds}$$

$$= 8.7 \text{ seconds.}$$

The resultant force acting to produce momentum is given at every instant by the difference between the ordinates of OAB and OAC . Take T seconds from N .

Area AKG represents the total momentum generated.

If v = the velocity in feet per second, and if we measure our mass in tons, we have

$$\begin{aligned} 400v &= \text{area KAG} \\ &= \frac{1}{2} \text{KG} \cdot \text{AG}, \\ \frac{\text{KG}}{\text{AG}} &= \frac{7}{20}, \\ \therefore 400v &= \frac{1}{2} \frac{7}{20} \times T^2 \times 32. \\ \therefore v &= 0.014 T^2. \end{aligned}$$

The velocity-time curve for the 20 seconds considered is shown in fig. 54, where the zero for the time in the equation above is 8.7 seconds.

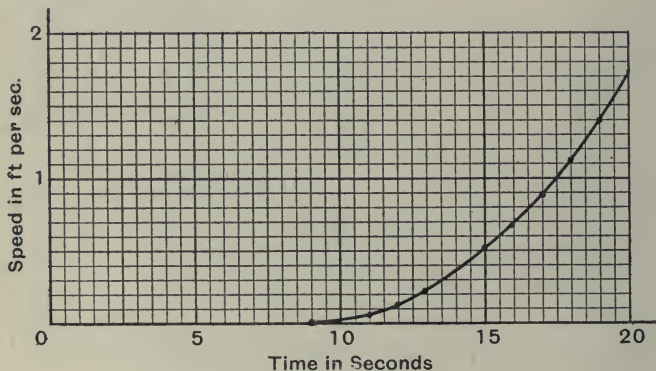

Fig. 54.

Example (7). *The curve below shows the total tractive resistance per ton at different speeds for a motor lorry on a road. The motor of the lorry is producing a constant total tractive force of 217 lbs. wt. If the weight of the lorry is 7 tons find the maximum speed attained. Find also the time taken to increase the speed from 9 to 13 miles per hour.*

The tractive force per ton is equal to $\frac{217}{7} = 31$ lbs. This is shown by the dotted line in the figure.

At maximum speed the change of velocity will be zero and hence the tractive force = the tractive resistance.

From the figure the maximum speed = 15.1 miles per hour.

To find the time we have, if δv is the gain of velocity in a small time δt ,

$$\text{Acceleration } (a) = \frac{\delta v}{\delta t} \text{ (nearly),}$$

$$\therefore \frac{1}{a} \delta v = \delta t.$$

Draw a curve representing $\frac{1}{a}$ and v , then the area under this curve gives the time.

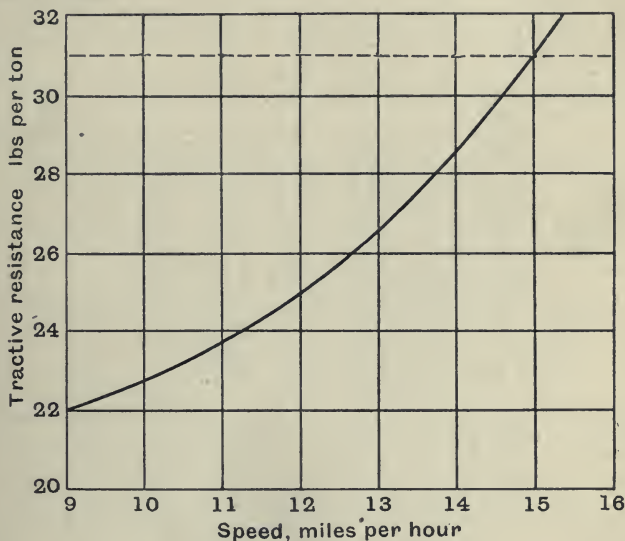

Fig. 55.

If R = the tractive resistance in lbs. wt. per ton,

Accelerating force per ton = $(31 - R)$ lbs. wt.

$$\therefore \text{Acceleration} = \frac{(31 - R) \times 32}{2240} \text{ ft. per sec. per sec.,}$$

$$\frac{1}{a} = \frac{2240}{(31 - R) \times 32} = \frac{70}{31 - R}.$$

Using fig. 55 we find

Speed in miles per hour	Tractive Force per ton in lbs.	Accelerating Force in lbs.	1
			Accel. in ft./sec. ²
9	22	9	7.78
10	22.8	8.2	8.54
11	23.75	7.25	9.66
12	25	6	11.7
13	26.5	4.5	15.5
13.5	27.5	3.5	20
14	28.5	2.5	28

The curve is shewn in fig. 56.

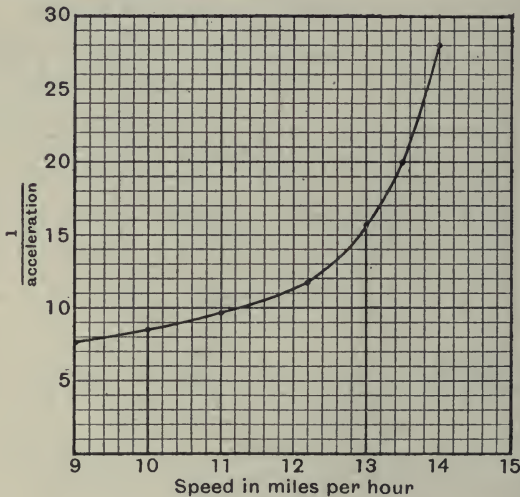

Fig. 56.

Scales 1 division = $\frac{1}{5}$ mile per hour = $\frac{2}{7} \frac{2}{5}$ foot per second.

1 division = $\frac{1}{1 \text{ foot per sec. per sec.}}$

The area under the curve between 10 miles per hour and 13 miles per hour

$$\begin{aligned} &= 167 \text{ squares} \\ &= 167 \times \frac{2}{7} \times \frac{2}{5} \times 1 \text{ seconds} \\ &= 49 \text{ seconds.} \end{aligned}$$

\therefore The time required = 49 seconds.

Example (8). *A machine-gun is mounted on an aeroplane, and when the latter is travelling at 50 miles per hour the gun is fired in the direction of travel for 15 seconds. Find the reduction in speed of the aeroplane due to this, and the force tending to move the gun relative to the aeroplane.*

Total weight of aeroplane 1800 lbs. Rate of firing 600 bullets per minute. Weight of bullet $\frac{1}{2}$ oz. Muzzle velocity of bullets 2000 feet per second.

The reaction of the force acting on the bullets is at every instant acting on the gun, and therefore on the aeroplane.

The time average of the force on the bullets = the change of momentum per second.

The mass discharged per second = $\frac{5}{16}$ lb.

The change of velocity = 2000 feet per second.

$$\begin{aligned} \therefore \text{Force} &= \frac{5}{16} \times 2000 \text{ pdls.} \\ &= 19\cdot5 \text{ lbs. wt.} \end{aligned}$$

This is the force tending to move the gun relative to the aeroplane.

Now let us examine the effect of the reaction of the force on the aeroplane. We may neglect the small change of mass due to the discharge of the bullets.

The force of $\frac{5}{16} \times 2000$ pdls. acts for 15 seconds. If v = the velocity of the aeroplane, in feet per second, at the end of the 15 seconds,

$$1800 \left(\frac{50 \times 88}{60} - v \right) = \frac{5}{16} \times 2000 \times 15,$$

or,

$$\begin{aligned} v &= 73\cdot3 - 5\cdot2 \\ &= 68\cdot1 \text{ feet per second} \\ &= 46\cdot5 \text{ miles per hour.} \end{aligned}$$

Example (9). *A balloon of total mass 620 lbs. is drifting horizontally when 40 lbs. of sand are suddenly released. Find the acceleration immediately after the sand is released.*

Since initially there is no vertical acceleration, the upthrust equals 620 lbs. wt. This upthrust is equal to the weight of the volume of air displaced by the balloon. The latter will be practically the same before and after the release of the sand.

After the release of the sand we have the net resultant force upwards

$$= \{620 - 580\} \text{ lbs. wt.}$$

$$= 40 \text{ lbs. wt.}$$

Let a = the vertical acceleration upwards immediately after release of the sand, then

$$40g = 580a,$$

i.e.
$$a = \frac{40 \times 32}{580}$$

$$= 2.2 \text{ feet per sec. per sec.}$$

As the balloon begins to ascend there will be an increasing resistance due to the motion, and the acceleration will decrease.

Example (10). *Water issuing from a nozzle, of 2 inches diameter, with a velocity of 50 feet per second, impinges on a vertical wall, the jet being at right angles to the wall. If there is no splash find the pressure exerted on the wall.*

If there is no splash the water will flow along the surface of the wall after impact. Let F be the pressure produced on the wall. This must equal

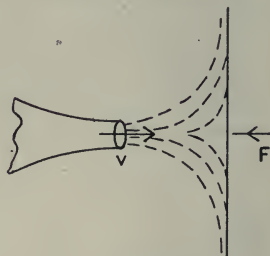

Fig. 57.

the change of momentum per second in a direction perpendicular to the wall

= the mass impinging per second \times the change of velocity in the direction of the force

$$= \rho av \cdot v, \text{ where } \rho \text{ is the density of water,}$$

$$= \rho av^2.$$

$$\therefore \text{ Pressure} = 62.5 \times \frac{\pi}{144} \times 50 \times 50 \text{ pdls.}$$

$$= \frac{62.5 \times \pi \times 2500}{32 \times 144} \text{ lbs. wt.}$$

$$= 107 \text{ lbs. wt.}$$

Example (11). *Fifty cubic feet of water are flowing per minute along the fixed vane AB shown in fig. 58 below. The speed along the vane is constant and equal to 20 feet per second. Find the magnitude and direction of the resultant force produced on the vane.*

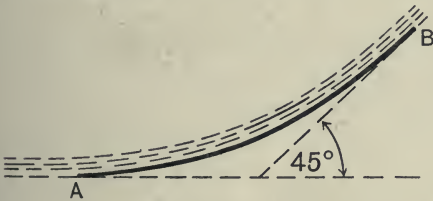

Fig. 58.

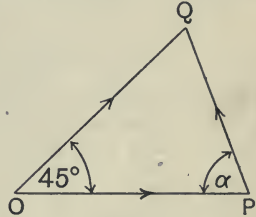

Fig. 59.

The mass flowing per second

$$= \frac{50 \times 62.5}{60}$$

$$= 52 \text{ lbs.}$$

The magnitude of the momentum per second at A or B

$$= 52 \times 20$$

$$= 1040 \text{ units.}$$

Let OP represent 1040 units at A, and OQ represent 1040 units at B (fig. 59).

The change of momentum per second is represented by PQ ,

$$= 2 \times 1040 \sin 22\frac{1}{2}^\circ$$

$$= 2080 \times 0.382$$

$$= 795 \text{ units}$$

$$= \text{Force of the vane on the water.}$$

The resultant force on the vane

$$= 795 \text{ pdls.}$$

$$= 24.8 \text{ lbs. wt.}$$

The direction of the force is given by the angle α ,

$$\alpha = 90 - 22\frac{1}{2}$$

$$= 67\frac{1}{2}^\circ.$$

Impulse

When two bodies impinge on one another, or a moving body impinges on a fixed object, there is a more or less sudden change of momentum. In many cases, it is impossible to measure the time of the impact or the rate at which the momentum of either body is changed, and in such cases, we can only measure the final effect of the stress which exists between the two bodies while they are in contact.

We have already seen that, $F \cdot t = Mv$. Where F is the average force acting, t the time, and Mv is the total change of momentum produced.

Since we cannot measure the force itself, in such cases we have to be content with estimating the value of the product, which can be obtained by measuring the value of the total change of momentum. This product is called the **Impulse**. There is no special name for the units in which it is measured. In the absolute system the unit will be the same as that of momentum, in the gravitation system the unit will be that of momentum multiplied by g (the numerical value of the acceleration due to gravity).

Example (12). *A mass of clay weighing 5 lbs. is thrown against a fixed wall with a velocity of 10 feet per second and sticks on the wall. What is the impulse of the blow?*

The impulse = the total change of momentum
 $= 5 \times 10$ F.P.S. units.

Here we cannot find what is the average pressure on the wall, or the pressure at any instant, since we know nothing about the time taken for the clay to come to rest. It may be asked, what happens to the wall, since it receives the same impulse, but in the opposite direction, as the clay. Theoretically there is the same change of momentum produced, but the mass of the wall and the earth, to which it is fixed, is so great that the velocity is negligibly small.

Magnitude of impulsive force. It may be noted that, generally, the time of the impact will be very short, and hence we may expect that the time average of the force will be large.

To give some idea of this, we may take two cases which have been investigated.

(1) Two ivory billiard balls impinge with equal velocities of 8 feet per second. It has been shewn that the time of the impact is $\frac{1}{4000}$ of a second, and that the maximum total pressure between the balls, which occurs at the instant when they are at rest, is equal to 1300 lbs.

(2) A leaden bullet weighing 0.03 lb. hits a steel target with a velocity of 1800 feet per second. The time required to stop the bullet is about $\frac{1}{18000}$ second.

Hence the time average of the force on the target

$$\begin{aligned} &= \frac{0.03 \times 1800}{\frac{1}{18000}} \text{ pdls.} \\ &= \frac{0.03 \times 1800 \times 18000}{2240 \times 32} \text{ tons wt.} \\ &= 13.5 \text{ tons wt.} \end{aligned}$$

In this case the pressure is probably nearly uniform during the stopping of the bullet.

In cases where the time during which the force is acting is very

small we speak of the impulse as a *blow*. As we have already seen, the time may be very short indeed and the average force will therefore be very large, since the product of the two is equal to the definite and finite change of momentum which occurs. In such cases, we can generally omit the effect of *steady forces* which may also be acting during the time of the blow, since the changes of momentum produced by them in the short time will be negligibly small.

Take the example of the bullet given on p. 77, and suppose it is fired vertically downwards at the target. By neglecting the steady force, namely the weight, in considering the impact, we are only neglecting 0.03 lb. wt. in comparison with 13.5 tons wt., i.e. we are making an error of $\frac{0.03 \times 100}{2240 \times 13.5}$ or $\frac{1}{10000}$ per cent.

Case of two bodies impinging. When two bodies impinge we may if we like consider the two as a single system. Hence in all cases of bodies impinging there is no total change of momentum due to the impact since there is no external force acting, or as it is often stated, *the total momentum before impact equals the total momentum after impact*. Another way of looking at the problem is to consider each body separately. Since the total change of momentum is zero, one body must lose exactly the same quantity as the other body gains. But the forces acting on each body are proportional to the change of momentum of each body, and since these are equal in magnitude and opposite in sign, *the forces on the two bodies are equal and opposite*. This is true whatever be the length of time during which the bodies are in contact. The two equal and opposite forces which are called into play together form what is called a *stress*.

Equilibrium. The second law of momentum is quite general in its application, and we may use it to investigate the forces acting on a body or system of bodies which is in equilibrium, i.e. at rest. In this case, the rate of change of momentum is zero, and therefore the resultant force, on the system or any part of it, must also be zero. By applying the law, firstly to the whole and afterwards

to the different parts, we can shew that, in every case, the interaction of any two bodies, or parts of a body which are connected or in contact, consists of a stress in which the two components are always equal in magnitude and opposite in sign. This fact is often stated in the form, "to every action there is an equal and opposite reaction," and is called Newton's *third* law of motion. As we have seen, it really follows directly from the second law of momentum. It forms the basis of investigation of the internal and external forces in statical problems.

Example (13). *A railway truck of mass 12 tons, moving with a velocity of 6 miles per hour, impinges on another truck weighing 10 tons, and moving in the same direction with a velocity of 2 miles per hour. When impact occurs the two trucks are automatically coupled together. Find the velocity of the trucks after impact.*

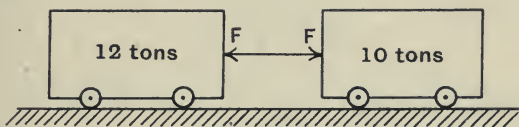

Fig. 60.

Let $F \cdot t$ be the impulse between the two trucks, and let v = the final velocity in the original direction of motion.

For the 12 ton truck,

$$F \cdot t = 12(6 - v).$$

For the 10 ton truck,

$$F \cdot t = 10(v - 2).$$

$$\therefore 72 - 12v = 10v - 20,$$

or
$$v = \frac{92}{22} = 4.17 \text{ miles per hour.}$$

The impulse of the blow = $F \cdot t$

$$= 12(6 - v) \times \frac{2240 \times 88}{60}$$

$$= 7220 \text{ F.P.S. units.}$$

Or, Momentum before impact = Momentum after impact,

i.e.
$$12 \times 6 + 10 \times 2 = (12 + 10)v,$$

$$\therefore v = 4.17 \text{ miles per hour.}$$

Example (14). A shell of mass m lbs. impinges obliquely on a fixed target and ricochets. If the striking velocity is u feet per second inclined at an angle θ to the normal at the point of contact, and the velocity of rebound is v feet per second inclined at an angle ϕ to the normal, find the resultant blow on the target.

Resolve the blow into two components, P and Q say, tangential and normal to the plane of the target.

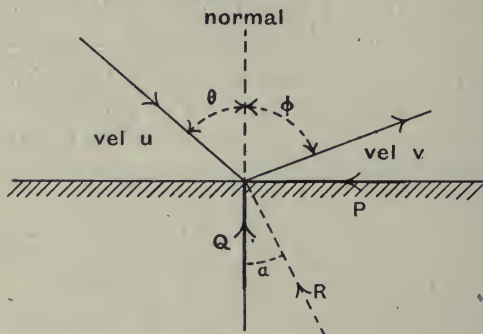

Fig. 61.

$$\begin{aligned} \text{Tangential,} \quad P &= mu \sin \theta - mv \sin \phi \\ &= m(u \sin \theta - v \sin \phi). \end{aligned}$$

$$\begin{aligned} \text{Normal,} \quad Q &= mu \cos \theta + mv \cos \phi \\ &= m(u \cos \theta + v \cos \phi). \end{aligned}$$

$$\begin{aligned} \text{Resultant (R)} &= \sqrt{P^2 + Q^2} \\ &= m \{u^2 \sin^2 \theta + v^2 \sin^2 \phi - 2uv \sin \theta \sin \phi \\ &\quad + u^2 \cos^2 \theta + v^2 \cos^2 \phi + 2uv \cos \theta \cos \phi\}^{\frac{1}{2}} \\ &= m \{u^2 + v^2 + 2uv \cdot \cos(\theta + \phi)\}^{\frac{1}{2}}. \end{aligned}$$

This makes an angle α with the normal such that

$$\begin{aligned} \tan \alpha &= \frac{P}{Q} \\ &= \frac{u \sin \theta - v \sin \phi}{u \cos \theta + v \cos \phi}. \end{aligned}$$

Or using vectors: The change of momentum equals the vector difference of mu and mv .

This is given by \overline{OB} in fig. 62, where \overline{OA} represents the initial momentum mu of the projectile, and \overline{BA} represents the final momentum mv .

The impulse of the blow = OB

$$= m \{u^2 + v^2 + 2uv \cos (\theta + \phi)\}^{\frac{1}{2}},$$

and the direction may be calculated from the figure.

It may be noted that generally we shall not be able to determine the values of v and ϕ , if we are merely given u and θ .

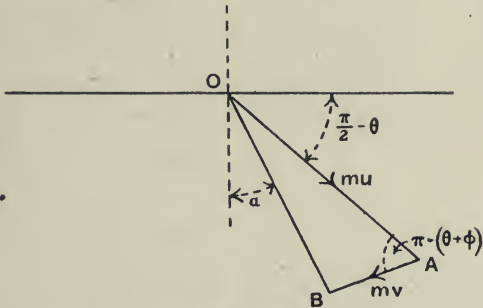

Fig. 62.

Example (15). *A hammer head weighing 1.2 lbs., and moving with a velocity of 16 feet per second, strikes a nail of 0.1 lb. weight and drives it $\frac{1}{2}$ inch into a piece of wood. Assuming no rebound of the hammer and the resistance to penetration of the nail constant find its magnitude.*

Let v = the velocity in feet per second with which the nail and hammer move immediately after the impact. Then by the conservation of momentum,

$$1.2 \times 16 = (1.2 + 0.1) v;$$

$$\therefore v = \frac{16 \times 1.2}{1.3}$$

$$= 14.8 \text{ feet per second.}$$

Since the resistance to penetration is constant the time rate of change of velocity will be uniform.

$$\begin{aligned} \therefore \text{the average velocity of penetration} &= \frac{14.8}{2} \\ &= 7.4 \text{ feet per second,} \end{aligned}$$

$$\text{and the time of penetration} = \frac{1}{24 \times 7.4} \text{ second.}$$

The resistance = rate of change of momentum

$$= 1.3 \times 14.8 \times 24 \times 7.4 \text{ pdls.}$$

$$= \frac{1.3 \times 14.8 \times 24 \times 7.4}{32} \text{ lbs. wt.}$$

$$= 107 \text{ lbs. wt.}$$

The magnitude of the blow between the hammer and the nail
= the change of momentum of the hammer

$$= 1.2 (16 - 14.8)$$

$$= 1.2 \times 1.2$$

$$= 1.44 \text{ F.P.S. units.}$$

Example (16). *A bar of metal 3 inches wide, 1 inch thick, and 15 feet long is to be passed through a rolling mill, the area of section being thereby reduced by $\frac{1}{4}$. The diameter of the rolls is 12 inches and they rotate at 200 revolutions per minute. Assuming that the speed at which the bar leaves the rolls is the same as that of the surface of the rolls, shew that the tangential impulse on the rolls when the bar is first gripped is 1180 absolute F.P.S. units. Shew also that, apart from the force required to overcome friction and to do the work of deforming the metal, a tangential force of 6.4 lbs. wt. is required to maintain the motion.*

The density of the metal = 480 lbs. per cubic foot.

The speed of the surface of the rolls

$$= \frac{2\pi \times 200}{60 \times 2}$$

$$= 10.47 \text{ feet per second}$$

$$= \text{the speed at which the bar leaves the rolls.}$$

Since the same volume of metal passes in and out of the rolls in a unit time, the velocity at which the bar is fed into the rolls

$$\begin{aligned} &= \frac{3}{4} \times 10.47 \\ &= 7.85 \text{ feet per second.} \end{aligned}$$

At starting, the whole bar is suddenly given this velocity,

$$\begin{aligned} \therefore \text{the impulse} &= 480 \times \frac{3}{144} \times 15 \times 7.85 \\ &= 1170 \text{ abs. F.P.S. units.} \end{aligned}$$

The steady tangential force required to maintain the motion

$$\begin{aligned} &= \text{the change of momentum per second} \\ &= \text{the mass per second} \times \text{the change of velocity} \\ &= \frac{480 \times 3 \times 7.85}{144} \times (10.47 - 7.85) \\ &= 204 \text{ pdls.} \\ &= 6.4 \text{ lbs. wt.} \end{aligned}$$

Examples. Chapter III

1. What do you understand by *momentum*? Define *force* in terms of this quantity.

In 5 seconds a car weighing 30 cwt. changes its speed from 20 feet per sec. to 27 feet per sec.; what uniform force must have been acting if it requires 50 lbs. per ton to just move the car steadily on the track? If the power is cut off at the end of the 5 seconds, what constant deceleration will result, and how far will the car run before coming to rest?

2. Express a force equal to the weight of 1 ton in (1) absolute F.P.S. units (poundals), (2) absolute c.g.s. units (dynes).

$$1 \text{ inch} = 2.54 \text{ centimetres.} \quad 1 \text{ pound} = 453.6 \text{ grams.}$$

$$\text{Acceleration due to gravity} = 981 \text{ cms. per sec. per sec.}$$

3. A car weighing 12 tons is ascending a slope of 3 in 100 against a frictional resistance equal to 1 per cent. of its weight. What pull is required in order that the car may increase its velocity by 1.5 miles per hour in one second?

4. Explain fully how you infer that at a given place on the earth a body's weight is proportional to its mass.

Two weights W, W' are connected by a light string passing over a light pulley. If the pulley moves upwards with an acceleration equal to that of gravity shew that the tension of the string is

$$\frac{4WW'}{W+W'}$$

5. A cage weighing 2000 lbs. can be raised or lowered in the shaft of a mine by a cable. Find the tension in the cable (1) when the cage is rising or falling with a uniform velocity, (2) when it is rising with an acceleration of 2 feet per second per second, and (3) when it is falling with an acceleration of 5 feet per second per second.

6. A tram-car weighing 17,000 lbs. is ascending a gradient of 1 in 20 with an acceleration of 1.2 feet per second per second. If the resistance is equal to 0.011 of the weight find the tractive force on the rails. If the tractive force and resistance remain the same, what would be the acceleration when travelling down a gradient of 1 in 30?

7. A truck is running on the level with a velocity of 20 miles per hour when the wheels are locked by the application of the brakes. If the coefficient of sliding friction between the wheels and the rails is 0.08, for how long and for what distance does the truck move before coming to rest?

Find the corresponding time and distance if the truck is moving down a slope of 1 in 100.

8. Find the magnitude and direction of the force which, acting on a mass of 4 pounds which is moving with a velocity of 8 feet per second, will in 4 seconds cause its velocity to be 8 feet per second in a direction at right angles to the original direction of motion.

9. A fire engine is delivering 312 gallons of water per minute through a nozzle of $1\frac{1}{8}$ inch diameter, fixed to the engine and inclined upwards at 30° to the horizontal. Find the vertical and horizontal reactions produced on the engine.

1 gallon of water weighs 10 lbs. 1 cubic foot of water weighs 62.5 lbs.

10. A motor-car has a machine-gun mounted on it, and when the car is at rest the gun is fired horizontally and straight to the front for 15 seconds. Find the velocity of the car at the end of this time.

Rate of firing, 600 bullets per minute; muzzle velocity of bullets, 2400 feet per second; weight of bullet, $\frac{1}{2}$ oz.; weight of loaded car, 18 cwt.; resistance to motion of the car, 16 lbs.

11. A mass of 10 lbs. is acted upon by a force P which varies with the time t according to the law, $P = 2 \sin \frac{\pi}{15} t$ lbs. weight, where t is in seconds. Plot the force-time curve from $t = 0$ to $t = 30$, and from it deduce the velocity-time curve, being given that the velocity is zero when the time is zero.

12. A boat is sailing at a constant velocity of 6 knots before a following wind of twice the velocity of the boat. The sail area is 450 square feet, and may be assumed a plane area perpendicular to the direction of motion of the boat. Find the total resistance to motion of the boat.

One cubic foot of air weighs 0·08 lb.

One knot equals 6080 feet per hour.

13. The relation between the total tractive resistance and the speed for a locomotive and train weighing 246 tons is given below. The total load on the driving wheels of the locomotive is 33 tons, and the coefficient of sliding friction between the wheels and the rails is $\frac{1}{5}$. The train is accelerated from rest as rapidly as possible on a level track. Plot a curve shewing the value of

$\frac{1}{\text{acceleration}}$ for different speeds, and from it estimate the time for the train to attain a speed of 45 miles an hour.

Speed in feet per sec.	0	5	7·5	10	20	30	40	50	60	70	80
Resistance in lbs. per ton	10·9	7·3	6·6	6·5	7·3	8·4	9·9	11·8	13·9	16·3	19·3

14. A torpedo boat fitted with hydraulic propulsion took in 1 ton of water per second in a direction perpendicular to the direction of motion of the boat, and discharged it horizontally astern with a velocity of 37·25 feet per second, relative to the boat. With this discharge the steady speed of the boat was 12·6 knots. Find the resistance to motion of the boat.

15. A locomotive while travelling at 40 miles per hour scoops up 760 gallons of water from a trough in a length of 500 yards. The water enters the scoop horizontally and is discharged into the tank of the locomotive vertically downwards. The delivery pipe has a diameter of 4 inches. Due to the change of momentum of the water, find (1) the horizontal resistance to the train's motion, (2) the reduction of pressure on the rails.

16. If the resistance to the motion of a train running at V miles per hour be $0·3(V + 10)$ lbs. per ton, find, graphically or otherwise, how long it will take to reduce the speed from 50 to 30 miles per hour in the case of a train running freely on the level. How far will the train run in the time?

17. A balloon weighing 800 lbs. is descending with a constant acceleration of 1 foot per second per second, when 50 lbs. of ballast is suddenly released. Find the magnitude and direction of the acceleration immediately after the release.

18. It is found that a bullet weighing 0.4 ounce and travelling at 2400 feet per second will just penetrate 36 inches of a certain wood. If a similar bullet with the same initial velocity is fired through 18 inches of the same wood, what will be the velocity when it emerges, and what is the force of resistance to penetration? Neglect the spin of the bullet.

19. Find the minimum plan area a parachute may have to enable a man weighing 10 stone to descend vertically at a final speed of not more than 25 feet per second. The weight of the parachute may be taken as 10 lbs., and the weight of one cubic foot of air 0.08 lb.

20. The velocity of flow in a water main of 6 inches diameter is 5 feet, per second. At one place the main is bent through an angle of 30° . Find the resultant force on the bend.

21. The inlet valve of a petrol engine is held on its seat by a spring which exerts a force of $1\frac{1}{2}$ lbs. If the valve opens downwards, weighs 3 ounces, and has a lift of 0.2 inch, find the time occupied in closing, and the velocity at the instant of closing.

22. A plumb-line, 7 feet long, is suspended from the roof of a railway carriage which is travelling along a straight level track. The plumb-bob is observed to be displaced 3 inches from the vertical through the point of suspension in the opposite direction to the direction of motion of the train. What is the acceleration of the train?

23. The acceleration of the reciprocating parts of a steam engine is given in feet per second per second by $120 \cos \theta + 20 \cos 2\theta$, where θ is the angle which the crank makes with the inner dead centre. If the weight of the reciprocating parts is 8 tons, find the accelerating force required in the direction of the line of stroke for the positions given by values of θ , 0° , 45° , 90° , 135° , 180° .

24. A small mass is suspended by two equal strings each inclined at 30° to the vertical. Shew that if one of the strings be suddenly cut the tension in the other is immediately increased by 50% .

25. Using a pile-driver with a hammer weighing 1 ton, it is found that a pile weighing 4 cwt. is driven 5 inches into the ground when the hammer falls a distance of 10 feet before striking. Assuming that there is no rebound of the hammer, and that the mean resistance and the drop remain the same, find the distance which the pile would be driven if the weight of the hammer were increased by $\frac{1}{4}$ ton.

26. The muzzle velocity of an eighteen-pounder shell is 1600 feet per second, and the gun recoils in its cradle a distance of 40 inches. The force exerted on the gun during recoil is $1\frac{1}{2}$ tons weight. Find the mass of the gun and its momentum at the beginning of recoil.

27. A sledge hammer of mass 14 lbs. falls freely from a height of 4 feet on an anvil and rises 6 inches after the blow. If the time of contact be $\frac{1}{100}$ of a second, find the mean force between the hammer and the anvil.

28. Two masses A and B, weighing 3 and 4 kilograms respectively, are connected by a light inextensible string which passes over a light frictionless pulley. The strings are vertical and just taut, the mass A resting on the ground and the mass B being supported 1 metre from the ground. If the support of B is suddenly removed, find (1) the time before B first reaches the ground, (2) the impulse in the string when B is first jerked off the ground, (3) the greatest height to which B subsequently rises.

29. A freely suspended steel bar, $1\frac{1}{4}$ inches diameter, was subjected to a pressure on the end by means of a charge of explosive. The pressure varied with the time in the manner shewn by the table below.

Find the magnitude of the impulse produced. If the bar weighs 12 lbs. find the velocity acquired.

Pressure, tons per sq. inch	0	27	50	37	22	8	3	0
Time, millionths of a second	0	1	2.5	5	10	20	30	40

30. Two equal masses A and B, moving in the same straight line and in the same direction, collide. Before the collision the distance of A behind B is diminishing at the rate of 6 feet per second and after the collision the distance of B ahead of A is increasing at the rate of 2 feet per second; also at one instant during collision both are moving at 10 feet per second. Find their velocities before and after collision.

CHAPTER IV

Angular Momentum

IN the chapter dealing with motion we saw that when a body was rotating about an axis it was convenient to use the term angular velocity to express the motion.

We must now investigate how forces may produce a change in angular velocity. In doing this, we do not have to introduce any new principles, but merely to apply those we have already stated. We will first of all deal with cases where the rotation is about a fixed axis, and where the forces applied are in a plane perpendicular to the axis of rotation.

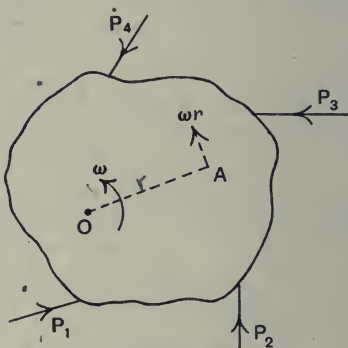

Fig. 63.

Suppose we have a body, as shewn in fig. 63, which is free to rotate about a fixed axis through O perpendicular to the plane of the paper. Let this body be acted upon by a set of forces P_1 , P_2 , etc.

Consider any small particle A of mass m situated at a distance r from O. If at a particular instant the angular velocity of the body is ω , then the linear velocity of A will be ωr in a direction perpendicular to OA.

The particle at A will also have an acceleration of magnitude $\omega^2 r$ towards O as found in Chapter II.

Now there will be certain forces acting on the particle at A, and we may conveniently consider these as having a total component, f say, perpendicular to OA and p , say, along AO.

We will deal first of all with the force f , acting perpendicular

to OA, leaving the force p for future consideration. It is obvious that the force p will have no effect on the rotation.

Let the angular velocity at the instant considered be increasing by an amount $\delta\omega$ in a time δt , or at the rate $\frac{d\omega}{dt}$. The linear acceleration of A perpendicular to OA is $r \frac{d\omega}{dt}$.

Applying the second law of momentum to the particle at A and measuring forces in absolute units we have

f = the rate of change of momentum,

i.e. $f = m \cdot r \cdot \frac{d\omega}{dt}$, where m is the mass of the particle.

Multiplying by r we have

$$f \cdot r = mr^2 \cdot \frac{d\omega}{dt} \dots\dots\dots(1).$$

Now we may imagine the whole body to consist of an infinite number of particles such as the one at A, and for each particle we shall get an equation similar to equation (1).

Adding the right and left-hand sides of all these equations we may express the sum thus :

$$\Sigma fr = \Sigma \left(mr^2 \cdot \frac{d\omega}{dt} \right).$$

But $\frac{d\omega}{dt}$ is the same for each of the particles, and hence we may write

$$\Sigma fr = \Sigma mr^2 \times \frac{d\omega}{dt}.$$

Σfr = the algebraic sum of the moments* of all the forces acting on the particles about O.

These include both external and internal forces. But the internal forces balance, and hence

Σfr = the algebraic sum of the moments of all the external forces about the axis O.

This is often called the **torque** or turning moment on the body and is denoted by the symbol τ .

* The *moment* of a force about a point is equal to the product of the magnitude of the force and the perpendicular distance from the point to the force.

$\Sigma mr^2 =$ the sum of the products of the mass of each particle multiplied by the square of its distance from O .

This is called the **moment of inertia*** of the body about the axis O , and is usually denoted by the symbol I .

The above equation may be written

$$\tau = I \frac{d\omega}{dt}.$$

Now just as the mass multiplied by the linear velocity is called linear momentum or more commonly momentum, so the product $I\omega$ is called the **angular momentum**, or sometimes the **moment of momentum**.

$I \frac{d\omega}{dt}$ is the same thing as $\frac{d(I\omega)}{dt}$, i.e. the rate of change of angular momentum.

Using absolute units for the torque we may write the second law of momentum as applied to rotation thus :

Torque = Rate of change of angular momentum.

If the torque is measured in gravitation units we must write

$$\text{Torque} = \frac{\text{Rate of change of angular momentum}}{g}.$$

Varying Torque

If the torque is varying, we can, as we did in dealing with linear momentum, either measure the rate of change of angular momentum at definite instants of time, or, we can find the total change of angular momentum for a definite interval of time.

Suppose the torque at different instants of time is given by the curve in fig. 64.

We have, Torque, $\tau = \frac{dI\omega}{dt}$.

* *Inertia* may be defined as that property of a body in virtue of which it will not change its state of motion or rest unless acted upon by some external force. For translational problems it is measured by the mass.

If we take a narrow strip as shewn shaded in the figure, the area = $\tau \delta t$
 = $\delta (\mathbf{I}\omega)$,

i.e. the area represents the change of angular momentum during time δt .

\therefore For any time θ from the start, the area under the torque-time curve from $t=0$ to $t=\theta$, measures the total change of angular momentum.

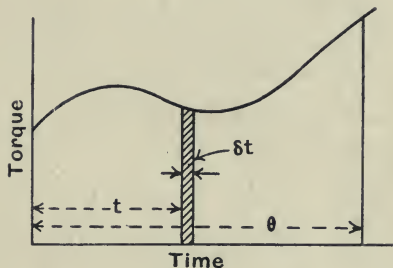

Fig. 64.

If the moment of inertia is constant, then the area under the curve represents the total change of angular velocity.

As in dealing with linear momentum, we may find the *time-average of the torque*. This is given by the area under the torque-time curve divided by the length of the base. Thus,

The time-average of the torque \times the time
 = the total change of angular momentum.

Impulsive Torque

In many problems we cannot measure the torque at each instant of time, either due to the total time being so short, or for other reasons. In such cases, all we can do is to measure the total effect produced by the torque during the time concerned. This is given us by the total change of angular momentum, and gives us the

product of the torque and time, or the area under the torque-time curve. This we may call the **impulsive torque** but we must remember that it is not a true torque but a product of *force, distance and time*, i.e. a product of *an impulse and a distance*.

Example (1). *Two masses M and m are supported by an inextensible string which passes over a pulley as shewn in fig. 65. Find the acceleration.*

Let I be the moment of inertia and r be the radius of the pulley.

The forces acting are shewn on the figure.

Let a = the acceleration of M downwards.

We have for M ,

$$Mg - T_1 = Ma \quad \dots\dots\dots(1).$$

For m , $T_2 - mg = ma \quad \dots\dots\dots(2).$

For the pulley the resultant torque

$$= (T_1 - T_2)r.$$

The angular acceleration $= \frac{a}{r}$,

$$\therefore (T_1 - T_2)r = \frac{Ia}{r} \quad \dots\dots\dots(3).$$

Adding (1) and (2) we get,

$$(T_2 - T_1) = (M + m)a - (M - m)g.$$

From this and (3),

$$-\frac{Ia}{r^2} = (M + m)a - (M - m)g,$$

i.e. The acceleration $= \frac{(M - m)g}{M + m + \frac{I}{r^2}}.$

We can also find T_1 and T_2 if desired.

It will be noted that here T_1 and T_2 are different, since the pulley requires a turning moment to change its angular velocity.

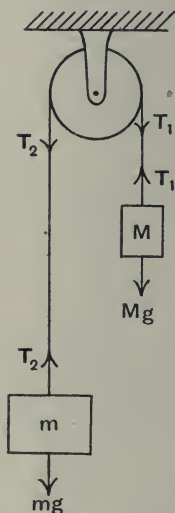

Fig. 65.

In example (3) on p. 64, we assumed that the moments of inertia of the pulleys were negligibly small, and in that case we had the tensions in the string on the two sides equal.

Example (2). *A gas engine works against a constant torque of 525 lbs. ft. If the gas supply is suddenly cut off and the resisting torque remains the same, find in how many revolutions the speed will fall from 250 to 240 revolutions per minute.*

The flywheel of the engine has a mass of 3 tons and it may be considered concentrated at a radius of 3 feet.

Since the resisting torque is constant the speed will decrease uniformly.

$$\begin{aligned} \text{The time average of the speed} &= \frac{250 + 240}{2} \\ &= 245 \text{ revolutions per minute.} \end{aligned}$$

If t is the time in seconds for the fall in speed, then the angular retardation = $\frac{10}{t}$ revolutions per minute per second

$$= \frac{20\pi}{60t} \text{ radians per sec. per sec.}$$

The torque = the change of angular momentum per second,

i.e.
$$525 \times 32 = 3 \times 2240 \times 3^2 \times \frac{\pi}{3t},$$

$$\therefore t = \frac{9 \times 2240 \times \pi}{525 \times 32}$$

$$= 3.77 \text{ seconds.}$$

\therefore The number of revolutions required

$$= \frac{245}{60} \times 3.77$$

$$= 15.4 \text{ revolutions.}$$

Example (3). *A flywheel, of moment of inertia 900 lb. ft. units, has a fan attached to its spindle. It is rotating at 60 revolutions per minute when the fan is suddenly immersed in water. If the*

resistance of the water be proportional to the square of the speed, and if the speed be halved in 3 minutes, find the initial retarding couple.

The retarding torque = $\lambda\omega^2$, where λ is a constant to be determined, and ω is the angular velocity in radians per second.

By the second law of momentum we have,

$$-\lambda\omega^2 = \mathbf{I} \frac{d\omega}{dt},$$

where \mathbf{I} is the moment of inertia.

This gives,
$$-\frac{dt}{d\omega} = \frac{\mathbf{I}}{\lambda} \cdot \frac{1}{\omega^2}.$$

Plot $-\frac{dt}{d\omega}$, i.e. $\frac{1}{\text{retardation}}$ and speed curve, using any suitable scale for $-\frac{dt}{d\omega}$. This is done in fig. 66.

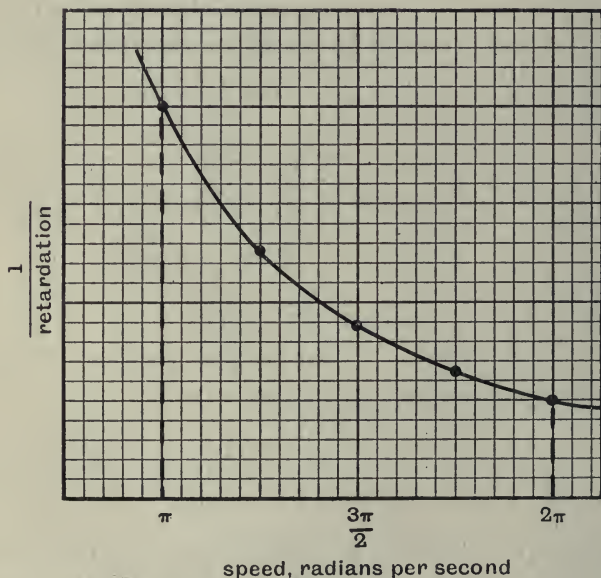

Fig. 66.

The scale for speed is, 1 division = $\frac{\pi}{20}$ radians per second.

The scale for $\frac{1}{\text{retardation}}$ is such that its value for ω equal to 2π radians per second is represented by 5 divisions,

$$\text{i.e.} \quad 5 \text{ divisions} = \frac{1}{\lambda} \times \frac{1}{4\pi^2},$$

$$\therefore 1 \text{ division} = \frac{1}{20\pi^2\lambda}.$$

Now if we take a narrow vertical strip between the base and the curve the area = $\frac{\delta t}{\delta \omega} \times \delta \omega$
= the time to change speed by amount $\delta \omega$.

\therefore The area under the curve between $\omega = \pi$ and $\omega = 2\pi$ represents 180 seconds.

The area = 198 small squares

$$= \frac{1}{20\pi^2\lambda} \times \frac{\pi}{20} \times 198 \text{ seconds}$$

$$= 0.157 \frac{1}{\lambda} \text{ seconds.}$$

$$\therefore 0.157 \times \frac{900}{\lambda} = 180,$$

$$\text{i.e.} \quad \lambda = 0.785.$$

The initial retarding couple = $0.785 \times 4\pi^2$ pdls. ft.
= 0.967 lb. ft.

Example (4). *A rope is being wound on to a drum from a coil on the ground, as shewn in fig. 67. The rope weighs 1 lb. a foot and the radius of the drum, which may also be taken as its radius of gyration*, is 2 feet. The mass of the drum is 80 lbs. When the drum starts there is one complete turn of rope on it, and it accelerates uniformly at the rate of 20 revolutions per minute per second. Find the couple at the end of 4 seconds. Neglect the diameter of the rope.*

* For definition of radius of gyration, see p. 105.

Let T_1 and T_2 be the tensions in the rope at the points shewn in the figure.

The weight of the hanging part of the rope will be $20g$ pdls.

The average speed during the first 4 seconds

$$= 40 \text{ revolutions per minute.}$$

The mass of the rope wound on in 4 seconds

$$= \frac{40 \times 4}{60} \times 4\pi \text{ lbs.}$$

The mass of the rope on the drum at the end of 4 seconds

$$= \left(\frac{8}{3} + 1\right) 4\pi \text{ lbs.}$$

$$= \frac{44\pi}{3} \text{ lbs.}$$

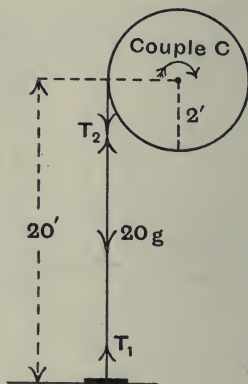

Fig. 67.

The moment of inertia of the drum and rope on it

$$= 80 \times 2^2 + \frac{44\pi}{3} \times 2^2$$

$$= 504 \text{ lbs. ft.}^2$$

The speed of the rope at the end of 4 seconds

$$= \frac{80 \times 4\pi}{60} \text{ feet per second.}$$

Let C = the couple in pdls. feet units on the drum. For the drum we have,

$$C - 2T_2 = 504 \times \frac{20 \times 2\pi}{60} \dots\dots\dots(1)$$

$$= 1055 \text{ pdls. ft.}$$

For the portion of the rope between the drum and the ground,

$$T_2 - 20g - T_1 = 20 \times \frac{40\pi}{60} \times 2 \dots\dots\dots(2)$$

$$= 84 \text{ pdls.}$$

Considering the coil, the pull τ_1 has to supply momentum to the new portion of the rope which is being jerked from the coil.

$$\text{The mass per second} = \frac{80 \times 4\pi}{60} \text{ lbs.}$$

$$\text{The change of velocity} = \frac{80 \times 4\pi}{60} \text{ feet per second.}$$

$$\begin{aligned} \therefore \tau_1 &= \left(\frac{80 \times 4\pi}{60} \right)^2 \dots\dots\dots(3) \\ &= 280 \text{ pdls.} \end{aligned}$$

From (2) and (3),

$$\begin{aligned} \tau_2 &= 84 + 280 + 640 \\ &= 1004 \text{ pdls.} \end{aligned}$$

From (1),

$$\begin{aligned} C &= 1055 + 2008 \\ &= 3063 \text{ pdls. ft.} \\ &= 96 \text{ lbs. ft.} \end{aligned}$$

Example (5). *In a press for stamping medals a flywheel is keyed to a vertical screw which rotates in a nut fixed to the frame. If M is the mass, k the radius of gyration of the screw and wheel, n the number of threads per unit length, r the mean radius of the screw, and μ the coefficient of friction, find an expression for the vertical acceleration of the screw and wheel when left to themselves.*

Imagine one complete turn of the thread stripped off from the nut and opened out as shewn in fig. 68.

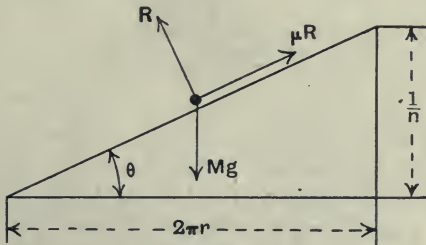

Fig. 68.

Let R = the normal pressure between the nut and screw. The friction μR will act at right angles to this and so as to oppose the motion.

The resultant force vertically downwards

$$= Mg - R \cos \theta - \mu R \sin \theta.$$

The horizontal force acting at a radius r

$$= R \sin \theta - \mu R \cos \theta.$$

Let a = the linear axial acceleration, and A = the angular acceleration. Then

$$\frac{a}{A} = \frac{\frac{1}{n}}{2\pi} = \frac{1}{2\pi n}.$$

We may apply the second law of momentum to the two components of the motion and we have

$$Mg - R (\cos \theta + \mu \sin \theta) = Ma \quad \dots\dots\dots(1),$$

and

$$R (\sin \theta - \mu \cos \theta) r = Mk^2 \cdot A \quad \dots\dots\dots(2).$$

Eliminating R from (1) and (2) we get

$$Mg - \frac{Mk^2 \cdot A}{r} \cdot \left(\frac{\cos \theta + \mu \sin \theta}{\sin \theta - \mu \cos \theta} \right) = Ma.$$

$$\therefore \left\{ \frac{k^2 \cdot 2\pi n}{r} \cdot \left(\frac{2\pi nr + \mu}{2\pi nr - \mu} \right) + 1 \right\} a = g.$$

$$\therefore \text{The vertical acceleration} = \frac{g}{\left\{ \frac{k^2 \cdot 2\pi n}{r} \left(\frac{2\pi nr + \mu}{2\pi nr - \mu} \right) + 1 \right\}}.$$

If $\mu = 0$ this reduces to $\frac{g}{\frac{k^2}{r} + 1}$.

Example (6). *In an inward-flow water turbine the water enters the wheel at a radius of 11 inches, with a velocity of 36 feet per second, and is inclined at 10° to the tangent at the point of entry. The water leaves the wheel with a velocity of 10 feet per second at a radius of 5 inches, and in a direction inclined back-*

wards at 50° to the tangent at the point of exit. If 400 cubic feet of water per minute pass through the wheel, and there is no shock at entry, find the turning moment produced.

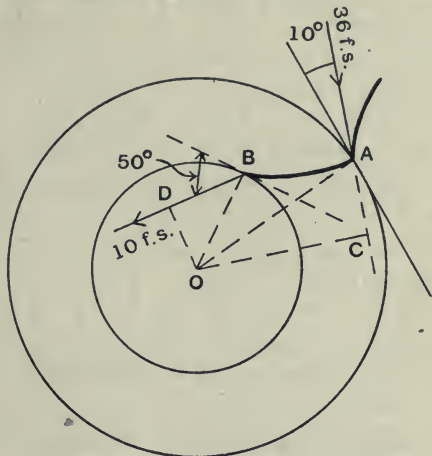

Fig. 69.

$$\begin{aligned} \text{The mass of water per second} &= \frac{400 \times 62.5}{60} \\ &= 417 \text{ lbs.} \end{aligned}$$

$$\begin{aligned} \text{The moment of momentum initially} &= 450 \times 36 \times OC. \\ \text{,, ,, finally} &= -417 \times 10 \times OD, \end{aligned}$$

where OC and OD are the perpendiculars from O on to the actual directions of motion of the water at entry and exit.

The turning moment

$$\begin{aligned} &= \text{Change of moment of momentum per second} \\ &= 417 \times 36 \times OC + 450 \times 10 \times OD \\ &= 417 \left\{ 36 \times \frac{11}{12} \cos 10^\circ + 10 \times \frac{5}{12} \cos 50^\circ \right\} \text{ pdls. ft.} \\ &= \frac{417}{32} \left\{ 36 \times \frac{11}{12} \times 0.985 + 10 \times \frac{5}{12} \times 0.643 \right\} \text{ lbs. ft.} \\ &= 458 \text{ lbs. ft.} \end{aligned}$$

Example (7). *Two toothed wheels, of moments of inertia 4 and 2 lbs. ft. units respectively, are arranged on parallel shafts. The first wheel is rotating with a speed of 500 r.p.m. when the second wheel, which is initially at rest, is suddenly made to mesh with it, by sliding the second wheel along the shaft. If the number of teeth on the wheels are 28 and 20 respectively, find the speed of each wheel immediately after they are in mesh.*

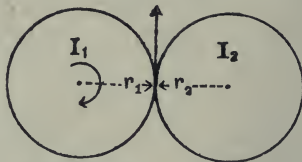

Fig. 70.

When the wheels are in mesh, since the circumferences have the same speed, we have

$$\frac{r_1}{r_2} = \frac{28}{20} = \frac{n_2}{n_1},$$

where n_1 and n_2 are the speeds, in revolutions per minute, after meshing.

Let P = the tangential component of the impulse between the teeth of the wheels during the period of meshing.

$$\text{For (1),} \quad P \cdot r_1 = 4 \times \frac{2\pi}{60} (500 - n_1).$$

$$\text{For (2),} \quad P \cdot r_2 = 2 \times \frac{2\pi}{60} n_2,$$

$$\text{i.e.} \quad \frac{r_1}{r_2} = \frac{2(500 - n_1)}{n_2},$$

$$\text{i.e.} \quad \frac{1000 - 2n_1}{n_2} = \frac{28}{20},$$

$$\text{and} \quad n_2 = 1.4n_1,$$

$$\therefore 1000 - 2n_1 = 1.4^2 \times n_1,$$

$$\text{or} \quad n_1 = \frac{1000}{3.96} = 253 \text{ r.p.m.}$$

$$\text{and} \quad n_2 = \frac{1400}{3.96} = 354 \text{ r.p.m.}$$

Moment of Inertia

The values of the moment of inertia of various bodies can be obtained by employing the integral calculus to effect the summation required, or we may employ certain graphical methods. Here we will state the values for a few bodies which are frequently met with in rotation problems.

Routh's Rule for Moment of Inertia

The following simple rule for rapidly obtaining the moment of inertia of many bodies dealt with in dynamics will be found very useful.

The moment of inertia about a symmetrical axis through the centre of gravity

$$= \text{Mass} \times \frac{\text{Sum of the squares of the perpendicular semi-axes}}{3, 4, \text{ or } 5}.$$

3, is to be used for a *rectangular* or *square* body.

4, is to be used for an *elliptical* or *circular* body.

5, is to be used for an *ellipsoidal* or *spherical* body.

Let us see how this is applied :

Rectangular plate

Suppose we want the moment of inertia about oz . Here the only axis perpendicular to the axis considered is the y -axis, the thickness being supposed negligibly small.

$$\therefore I_{oz} = \frac{M \frac{h^2}{4}}{3} = \frac{1}{12} M h^2.$$

$$\text{Similarly, } I_{oy} = \frac{1}{12} M b^2$$

$$\text{and } I_{oz} = \frac{1}{12} M (b^2 + h^2),$$

where oz is the axis perpendicular to the plane of the figure.

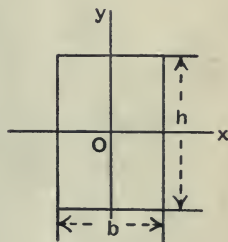

Fig. 71.

Circular disc or cylinder

Let r = the radius.

$$I_{oz} = \frac{M(r^2 + r^2)}{4} = \frac{Mr^2}{2}.$$

For a thin disc

$$I_{oz} = \frac{Mr^2}{4} = I_{oy}.$$

Sphere

$$\begin{aligned} I_{oz} &= M \frac{r^2 + r^2}{5} \\ &= \frac{2}{5} Mr^2 \\ &= I_{ox} = I_{oy}. \end{aligned}$$

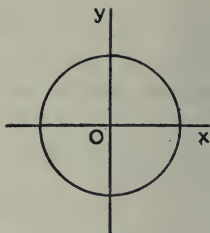

Fig. 72.

Moment of Inertia about any Axis

For determining the moment of inertia about an axis which does not pass through the centre of gravity we may employ the following :

The moment of inertia of a body about any axis is equal to the moment of inertia about a parallel axis through the centre of gravity plus the product of the mass and the square of the distance between the two axes.

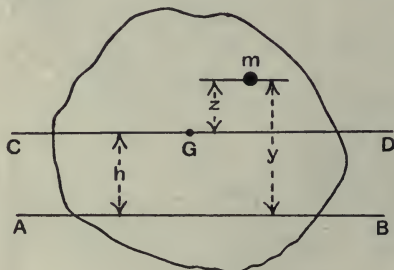

Fig. 73.

Referring to fig. 73, let CD be an axis through the centre of gravity parallel to the axis AB. Then

$$\begin{aligned}
 I_{AB} &= \sum my^2 \\
 &= \sum m(z+h)^2 \\
 &= \sum mz^2 + \sum mh^2 + \sum m \cdot 2hz \\
 &= \sum mz^2 + Mh^2 + 2h \sum mz,
 \end{aligned}$$

where M = the total mass.

Now $\sum mz^2 = I_{CD}$,

and $\sum mz =$ the moment of the mass of all the particles about CD
 $=$ zero, since the centre of gravity lies on CD . See p. 117.

$$\therefore I_{AB} = I_{CD} + Mh^2.$$

Plane Lamina

Another proposition which is often useful in determining moments of inertia is as follows :

In the case of a plane lamina or flat body in which the thickness is negligibly small *the moment of inertia about an axis perpendicular to the plane is equal to the sum of the moments of inertia about any two axes in the plane mutually at right angles to each other and intersecting on the first axis.*

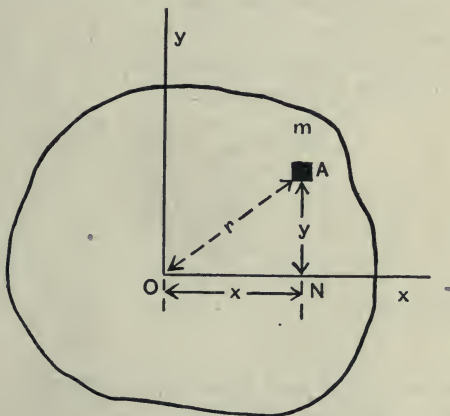

Fig. 74.

Take the axis of oz perpendicular to the plane, and the axes ox and oy in the plane.

If m is the mass of a particle A, fig. 74, then

$$\begin{aligned} \mathbf{I}_{oz} &= \Sigma m r^2 \\ &= \Sigma m \text{OA}^2 \\ &= \Sigma m (\text{ON}^2 + \text{NA}^2) \\ &= \Sigma m (x^2 + y^2) \\ &= \Sigma m x^2 + \Sigma m y^2 \\ &= \mathbf{I}_{oy} + \mathbf{I}_{ox}. \end{aligned}$$

Hoop about a diameter

The moment of inertia \mathbf{I}_{oz} for a thin-rimmed hoop of radius r and mass m equals mr^2 .

$$\therefore \mathbf{I}_{ox} + \mathbf{I}_{oy} = mr^2.$$

But

$$\mathbf{I}_{ox} = \mathbf{I}_{oy},$$

$$\therefore \mathbf{I}_{ox} = \frac{1}{2}mr^2.$$

Hollow cylinder about its axis

Let R and r be the external and internal radii respectively. Let h be the height, and ρ be the density.

Treat the hollow cylinder as the difference between two solid cylinders of radii R and r respectively.

$$\begin{aligned} \mathbf{I} &= \rho\pi R^2 h \frac{R^2}{2} - \rho\pi r^2 h \frac{r^2}{2} \\ &= \rho\pi (R^2 - r^2) h \left(\frac{R^2 + r^2}{2} \right) \\ &= M \frac{R^2 + r^2}{2}, \end{aligned}$$

where M is the mass.

Thin rod

This may be treated as a thin rectangular plate in which *two* of the axes are negligibly small.

Let l be the length of the rod and m be the mass.

The moment of inertia about an axis through the middle

$$\begin{aligned} & \frac{l^2}{4} \\ & = m \cdot \frac{4}{3} \text{ (Routh's rule)} \\ & = \frac{ml^2}{12}. \end{aligned}$$

The moment of inertia about one end

$$\begin{aligned} & = \frac{ml^2}{12} + m \cdot \left(\frac{l}{2}\right)^2 \\ & = \frac{ml^2}{3}. \end{aligned}$$

Radius of Gyration

In the case of a thin-rimmed hoop all the mass may be considered to act at the same radius, viz. the radius of the hoop r , and hence the moment of inertia about an axis through the centre perpendicular to the plane $= mr^2$, where m is the total mass.

In the case of a body where the mass is at different distances from the axis of rotation, it is often convenient to imagine it replaced by a simpler body having all the mass concentrated at the same radius. This body must have the same dynamical effect so far as rotation is concerned as the original body.

If M = the mass of the original body,

I = the moment of inertia of the original body,

and k = the radius at which we may imagine the whole mass to be acting, then

$$Mk^2 = I,$$

or

$$k^2 = \frac{I}{M}.$$

k is called the radius of gyration.

For example, the moment of inertia of a flywheel = 6750 ft.² lbs.

The mass of the wheel = 1100 lbs.

$$\begin{aligned} \therefore \text{The radius of gyration} &= \sqrt{\frac{6750}{1100}} \\ &= 2.48 \text{ feet.} \end{aligned}$$

Example (8). *The figure shows a sheave of an eccentric, the sheave consisting of a steel disc of radius 6 inches and thickness 1 inch, with a hole of 4 inches diameter, the centre of which is 3 inches from the centre of the disc. Find the moment of inertia of the sheave about the axis of the hole.*

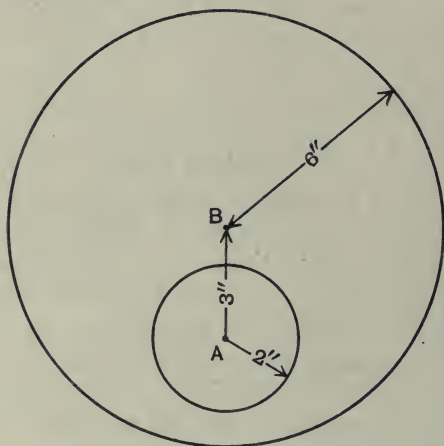

Fig. 75.

The moment of inertia about A = the moment of inertia of the complete disc about B + the mass of the complete disc $\times AB^2$ - the moment of inertia of the part removed for the hole about A

$$= \rho \times \pi \times \frac{1}{4} \times \frac{1}{12} \left\{ \left(\frac{1}{2} \right)^2 + \left(\frac{1}{4} \right)^2 \right\} - \rho \pi \times \frac{1}{36} \times \frac{1}{12} \times \left(\frac{1}{8} \right)^2,$$

where ρ is the density, i.e. 480 lbs. per cubic foot,

$$\begin{aligned} \therefore I_A &= \frac{30\pi}{16} - \frac{10\pi}{648} \\ &= 5.8 \text{ lbs. ft.}^2 \end{aligned}$$

Examples. Chapter IV

1. Define the term moment of inertia as applied to a revolving mass.

A wheel of mass 50 lbs., rotating at 400 revolutions per minute, is brought to rest in 10 seconds by the application of a brake. Find the average frictional torque during the 10 seconds, if the whole mass of the wheel may be considered as situated at 18 inches from the axis.

2. A wheel of 200 lbs. weight and radius of gyration 2 feet is mounted on smooth bearings. The axle is 3 inches in diameter, and a weight of 40 lbs. hangs from a string wrapped round the axle. With what acceleration will the weight fall?

If after the weight has fallen through 6 feet from rest the string is cut and a retarding tangential force of 20 lbs. applied on the axle, how many revolutions will the wheel make before coming to rest?

3. A uniform circular disc of weight W is mounted with its axis horizontal and a light string passing over it carries weights M and $M+m$, at its ends. If the string does not slip on the disc, shew that when the system is in motion the acceleration of the weights is equal to

$$g \frac{2m}{4M + 2m + W}.$$

Find also the values of the tensions in the two portions of the string, and the resultant thrust on the bearings of the disc.

4. The axle of a flywheel is 6 inches in diameter. A weight of 20 lbs., hung at the end of a fine flexible wire which is wrapped round the axle, is just sufficient to overcome friction, and when put in motion, falls with a constant velocity. When an additional 50 lbs. is hung on the wire it descends with a constant acceleration equal to $\frac{g}{10}$. Find the value at the end of 10 seconds, of (1) the velocity of the weight, (2) the angular velocity of the flywheel. Find also the moment of inertia of the flywheel.

5. In the previous question if instead of the additional 50 lbs. being hung on the wire, the weight of 20 lbs. is pulled downwards with a steady force of 50 lbs. wt., what will be its acceleration?

6. A propeller and shaft, the moment of inertia of which is 500 lbs. ft.² units, is observed to slow up in the manner given in the table below. Find

the retarding torque at speeds of 800 and 300 revolutions per minute, and the number of revolutions made during this fall of speed.

Speed, revs. per min.	1000	875	765	645	550	460	375	305	240
Time, seconds	0	15	30	45	60	75	90	105	120

7. The drum of a winch has an effective diameter of 12 inches. The axis is horizontal and 40 feet above the ground. One end of a chain, weighing 2 lbs. per foot, is fixed to the drum, and the chain hangs vertically to a loose heap on the ground where there are 40 feet of chain. The drum is rotated at a constant speed so that 60 feet of chain are wound up per minute. Neglecting friction, find the couple required to rotate the drum. Draw a curve shewing the couple during the last 40 seconds before the chain is completely wound up.

8. An oscillating rotary valve has a motion given by the equation,

$$\theta = 3 \sin 4t,$$

where θ is the angle turned through in time t . Shew that the torque varies directly as the angle turned through.

9. A disc, the moment of inertia of which is 300 lbs. ft.² units, is retarded from a speed of 50 revolutions per minute by a resisting couple which varies directly with the speed. If the time for the speed to be reduced to 20 revolutions per minute is 4 minutes, find the initial retarding couple.

10. In a rifle barrel the grooves make one complete turn in 10 inches. A bullet of mass 0.4 ounce and radius of gyration 0.11 inch has a muzzle velocity of 2000 feet per second. What are the values of the effective impulse and impulsive couple exerted on the bullet during its travel along the barrel?

11. In order to determine the moment of inertia of a flywheel and its shaft it was speeded up by a belt which was then thrown out of gear. When coming to rest under its own friction it was found to take 42 seconds to change the speed from 200 to 180 revolutions per minute. With a brake giving a constant torque of 18 lbs. feet it took only 18 seconds to change from 200 to 180 revolutions per minute. Find the moment of inertia of the flywheel and shaft.

12. A cylindrical nut, whose internal and external radii are 1 inch and 4 inches respectively, works along a vertical screwed shaft. The pitch of the screw is $\frac{1}{2}$ inch and the coefficient of friction $\frac{1}{4}$. If the nut be set turning so as to travel down the shaft, shew that its linear retardation will be approximately 0.05 foot per second per second.

13. A cylinder rolls down a plane inclined to the horizontal at an angle θ . Shew that the acceleration of the centre of the cylinder is $\frac{2}{3}g \sin \alpha$.

14. As a flywheel rotates it winds up on its axle a light inextensible string which is attached to a weight of 50 lbs. resting on the ground in such a position that the string is vertical when it becomes tight. The moment of inertia of the flywheel is 200 lbs. ins.², and the diameter of the axle is 2 inches. Shew that at the instant when the weight leaves the ground the angular velocity of the flywheel is reduced in the ratio 4 to 5.

15. A uniform circular trap-door, 2 feet in diameter, is to be provided with a stop in such a way that when the door is thrown open against the stop there shall be no jar on the hinge. Find where the stop must be placed.

16. A water turbine is taking 500 cubic feet of water per minute. The water enters the wheel at a radius of 10 inches and with a velocity of 25 feet per second inclined at 20° to the tangent at the point of entry. If there is no shock at entry, and the discharge is radial, find the turning moment on the wheel.

17. A uniform circular disc of diameter 1 foot is rotating about an axis through its centre perpendicular to its plane at a speed of 100 revolutions per minute; this is brought up to a stationary disc of the same mass but of diameter 2 feet, which is free to rotate about the same axis. After rubbing the two rotate together; find the common angular velocity.

18. A door is 6 feet 6 inches high and 2 feet 6 inches wide and weighs 40 lbs. Find the moment of inertia about the hinges.

19. A hollow sphere has an external diameter of 9 inches and an internal diameter of 8 inches. It is made of metal the density of which is 480 lbs. per cubic foot. Find the moment of inertia about a diameter.

20. The rim of a cast-iron flywheel is rectangular in cross-section, the thickness being 6 inches. The outside and inside diameters of the rim are 4 feet and 3 feet 3 inches respectively. If the density of cast-iron is 460 lbs. per cubic foot, find the moment of inertia of the flywheel. The hub and spokes may be omitted.

21. A round rod, $\frac{1}{2}$ inch in diameter, is screwed into a solid sphere of 6 inches diameter, the axis of the rod being along a radius of the sphere. The length of the rod from the end to the centre of the sphere is 3 feet, and both the rod and sphere are of steel the density of which is 490 lbs. per cubic foot. Find the moment of inertia about an axis (1) through the centre of gravity, (2) through the end of the rod.

CHAPTER V

CENTRIFUGAL FORCE AND CENTRE OF MASS

Centrifugal Force

WHEN we were applying the second law of momentum to rotation we dealt only with the tangential components of the forces acting on the particles ; we must now deal with the normal forces.

Suppose we have a mass m rotating in a circle of radius r with an angular velocity ω . We have already shewn that such a mass has, continually, an acceleration towards the centre of magnitude $\omega^2 r$. This means that there is a rate of change of momentum towards the centre equal to $m\omega^2 r$. In order to produce this rate of change of momentum we must have a force F acting always towards the centre. This force is sometimes called the *centripetal force*.



Fig. 76.

Thus,

$$F = m \cdot \omega^2 r \dots \dots \dots (1).$$

The force may be provided, in the case just considered, by attaching the mass m to the centre of rotation by means of a string. The tension in this string will be equal to $m\omega^2 r$.

In the case where m is a small particle of a body, the force is provided by an internal stress being set up in the material of the body. That this is so, is well known, since it is possible by rotating bodies at sufficiently large speeds to cause the internal stresses set up to be greater than the material can withstand, with the result that the body flies to pieces. Many cases have occurred, frequently with disastrous results, where engine flywheels, for

example, have suddenly flown to pieces due to the governor sticking, and the speed increasing greatly beyond the normal.

In dealing with cases of rotation where the angular velocity is constant it has become customary to use the principles of statics to solve problems. There is a good deal to be said for this method, but unfortunately it is often a stumbling block to beginners. However, the method has become so usual that it is not desirable to try to change it, and we must adopt it. In statical problems the velocity is zero and the rate of change of momentum is zero. The resultant force is therefore zero. Now, taking the case of the rotating mass just considered, let us imagine that there is a force equal to $m\omega^2 r$ acting away from the centre instead of towards the centre, and that instead of the body having a rate of change of momentum it is in equilibrium. The resultant force on the mass must be zero,

$$\therefore F - m\omega^2 r = 0,$$

where F is the pull in the string towards the centre.

This *imaginary* force equal in magnitude to $m\omega^2 r$ and acting *away from* the centre of rotation, which we apply to make the problem a statical one, is called the **centrifugal force**.

It is exactly equal in magnitude to the true force which must act to produce the acceleration but is in the opposite direction. It is obvious that all *dynamical* problems might be treated as *statical* problems if we introduce imaginary forces equal and opposite to the rates of change of momentum. It is often convenient to do this.

Example (1). *A mass of m lbs. is suspended from a string of length l and is rotating in a horizontal circle of radius r . Find the time of one revolution and also the tension in the string.*

Such an arrangement is called a conical pendulum.

We will treat this problem firstly as *dynamical* and secondly as *statical*.

(1) *Dynamical.*

Let T be the tension in the string, and ω the angular velocity.

The resultant force vertically = $T \cos \theta - mg$.

The resultant force horizontally = $T \sin \theta$.

The rate of change of momentum vertically = 0.

The rate of change of momentum horizontally (towards C) = $m\omega^2 r$.

From the second law of momentum

$$T \cos \theta - mg = 0 \dots\dots\dots(a),$$

and $T \sin \theta = m\omega^2 r \dots(b).$

From (a) and (b),

$$\tan \theta = \frac{\omega^2 r}{g},$$

i.e. $\omega^2 = \frac{g}{r \cot \theta}$
 $= \frac{g}{h}$, where $h = OC$,
 $\therefore \omega = \sqrt{\frac{g}{h}}$.

For one revolution the angle turned through = 2π .

$$\begin{aligned} \therefore \text{The time for one revolution} &= \frac{2\pi}{\omega} \\ &= 2\pi \sqrt{\frac{h}{g}}. \end{aligned}$$

From (a),

$$\begin{aligned} T &= \frac{mg}{\cos \theta} \\ &= \frac{mgl}{h}. \end{aligned}$$

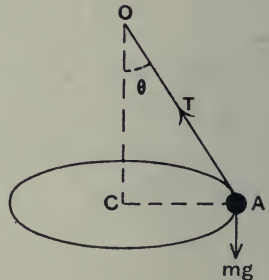

Fig. 77.

(2) *Statical.*

Apply a force $m\omega^2 r$ as shewn in fig. 78. We may now treat the mass m as in equilibrium under the action of the three forces, T , $m\omega^2 r$, and mg .

Resolving vertically and horizontally, we have

$$T \cos \theta - mg = 0,$$

and $T \sin \theta - m\omega^2 r = 0.$

From these, as before, we get

$$T = mg \frac{l}{h}$$

and

$$\omega = \sqrt{\frac{g}{h}}.$$

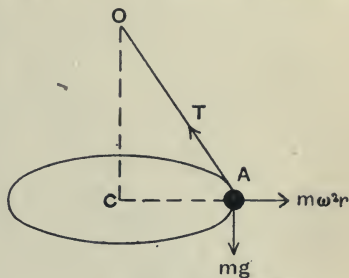

Fig. 78.

Example (2). *A simple governor for operating the throttle valve of a steam engine is shewn in fig. 79. The vertical spindle, to which is fixed the piece AB, derives its rotation from the crank shaft of the engine. The sleeve DC can slide up and down the spindle, and moves a lever, the forked end of which fits in a groove on the sleeve. This lever opens or closes the throttle valve.*

It is required to find the total mass W of the loaded sleeve so that the angle CAH may be 30° , when the engine is moving at its normal speed and rotating the governor spindle at 120 revolutions per minute.

Take $AB = CD = 3$ inches.

$CH = HA = BG = GD = 10$ inches.

The weight of each ball = 3 lbs.

The radius of the ball path = $(1.5 + 10 \sin 30^\circ)$
 $= 6.5$ inches.

The centrifugal force per ball = $\frac{3 \times 16\pi^2 \times 6.5}{12}$ pdls.
 $= 26\pi^2.$

Let P equal the pull in each of rods CH and DG,
 and Q " " " HA and GB.

Consider one ball and resolve the forces vertically and horizontally.

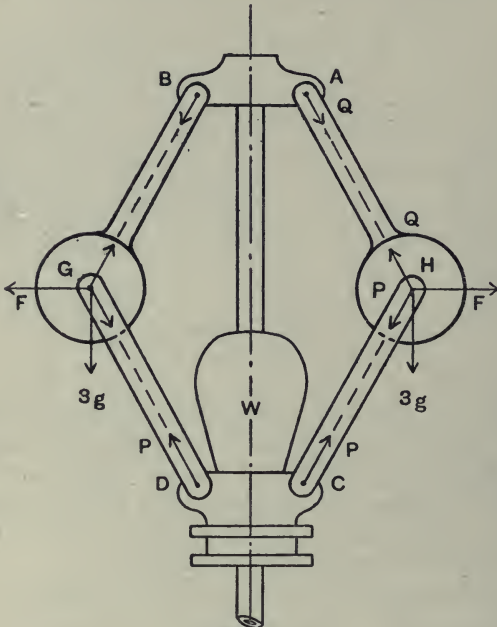

Fig. 79.

We have

$$\left. \begin{aligned} P \cos 30^\circ - Q \cos 30^\circ + 3g &= 0 \\ (P + Q) \sin 30^\circ - 26\pi^2 &= 0 \end{aligned} \right\},$$

or

$$\left. \begin{aligned} P - Q &= -\frac{96 \times 2}{\sqrt{3}} \\ P + Q &= 26\pi^2 \times 2 \end{aligned} \right\}.$$

$$\therefore 2P = 52\pi^2 - \frac{96 \times 2}{\sqrt{3}}$$

$$= 512 - 111$$

$$= 401 \text{ pdls.}$$

$$\therefore P = \frac{200 \cdot 5}{32} = 6 \cdot 26 \text{ lbs. wt.}$$

Revolving vertically for the sleeve we have

$$2P \cos 30^\circ = Wg.$$

$$\therefore W = \frac{401 \times \sqrt{3}}{2 \times 32}$$

$$= 10.85 \text{ lbs. wt.}$$

Centre of Mass, or Centre of Inertia

In dynamical problems when we are dealing with a body of finite size and not merely a small particle, we may consider the body as consisting of a very large (infinite) number of small particles. These particles may be moving with different velocities, e.g. a body rotating about an axis, and in estimating the total change of momentum we shall require to find the vector sum of the changes of momentum of all the particles.

Take the case of a body the mass of which may be considered concentrated in one plane, e.g. a thin sheet of material. Let the body be rotating about a fixed axis with an angular velocity ω .

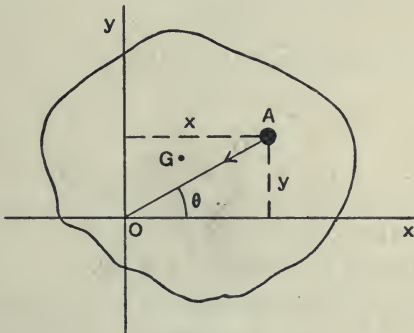

Fig. 80.

Suppose we take two axes Ox and Oy in the body, for convenience at right angles, and passing through the axis of rotation. Let x and y be the coordinates of a particle of mass m (fig. 80).

The rate of change of momentum is $m\omega^2 r$, where $r = OA$, and is in direction AO .

The rate of change of momentum in the direction Ox

$$= m\omega^2 r \cos \theta$$

$$= m\omega^2 x.$$

The rate of change of momentum in the direction Oy

$$= m\omega^2 r \sin \theta$$

$$= m\omega^2 y.$$

For the whole body we have,

$$\text{Total force in direction } xO = \Sigma m\omega^2 x = P.$$

$$,, \quad ,, \quad yO = \Sigma m\omega^2 y = Q.$$

$$\therefore P = \omega^2 \Sigma mx,$$

and

$$Q = \omega^2 \Sigma my.$$

Now we can obviously find a point, coordinates \bar{x} , \bar{y} , say, in the body such that

$$M\bar{x} = \Sigma mx$$

and

$$M\bar{y} = \Sigma my,$$

where M = the total mass of the body,

i.e.

$$\bar{x} = \frac{\Sigma mx}{M},$$

and

$$\bar{y} = \frac{\Sigma my}{M}.$$

The point whose coordinates are \bar{x} and \bar{y} is called the **centre of mass** or **centre of inertia** of the body.

The resultant force in the direction xO and yO is given by

$$P = M\bar{x} \cdot \omega^2$$

and

$$Q = M\bar{y} \cdot \omega^2,$$

and instead of thinking of the individual particles we may imagine the whole mass of the body concentrated at the *centre of mass*.

The single resultant force required to produce the change of momentum

$$\begin{aligned} &= \sqrt{P^2 + Q^2} \\ &= \omega^2 M \cdot \sqrt{\bar{x}^2 + \bar{y}^2} \\ &= M\omega^2 OG^2, \end{aligned}$$

where G is the centre of mass of the body.

The **centre of gravity** of a body is the point through which the resultant force on the body due to gravity always acts, no matter what the position of the body.

It is easy to shew that the *centre of gravity* coincides with the *centre of mass*.

In fig. 80 imagine the weight of each particle, such as m at A , to act at right angles to the plane of the figure.

Let \bar{x}' and \bar{y}' be the coordinates of the centre of gravity. Taking moments about the axes Oy and Ox , we have

$$Mg \times \bar{x}' = \Sigma mgx,$$

i.e.
$$\bar{x}' = \frac{\Sigma mx}{M},$$

and
$$Mg \times \bar{y}' = \Sigma mgy,$$

i.e.
$$\bar{y}' = \frac{\Sigma my}{M}.$$

From the previous article we see that, $\bar{x}' = \bar{x}$, and $\bar{y}' = \bar{y}$, and hence the centre of gravity coincides with the centre of mass.

Example (3). *A motor omnibus, when fully loaded, weighs $6\frac{1}{2}$ tons and the height of the centre of gravity is 4 feet 10 inches above the ground, and may be assumed to be in the vertical plane midway between the wheels. The effective breadth of the wheel base is 6 feet 8 inches. Assuming no side slip, what is the maximum speed at which the omnibus can take a corner of 5 yards mean radius without beginning to overturn?*

The omnibus keeps the middle of the road so that the wheel base is horizontal.

What minimum coefficient of friction is required to prevent side slip?

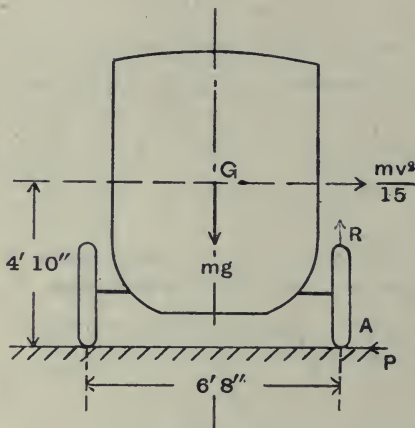

Fig. 81.

Let v = the maximum speed in feet per second, and m = the mass of the loaded omnibus.

The acceleration of the centre of gravity = $\frac{v^2}{r}$

$$= \frac{v^2}{15} \text{ feet per sec. per sec.}$$

The centrifugal force acting at the centre of gravity = $\frac{mv^2}{15}$.

When overturning is about to begin the pressure between the inner wheels and the road will be zero.

Let R = the normal pressure on the outer wheels, and P = the tangential pressure preventing skidding.

Taking moments about A we have

$$\frac{mv^2}{15} \times 58 - mg \times 40 = 0,$$

i.e.
$$v^2 = \frac{40 \times 15 \times 32}{58}$$

$$= 333,$$

$$\therefore v = 18.2 \text{ feet per second}$$

$$= 12.4 \text{ miles per hour.}$$

For P we must have

$$\begin{aligned} P &= \frac{mv^2}{15} \\ &= \frac{6.5 \times 2240 \times 18.2^2}{15} \text{ pdls.} \\ &= 4.5 \text{ tons wt.} \end{aligned}$$

Similarly

$$\begin{aligned} R &= mg \text{ pdls.} \\ &= 6.5 \text{ tons wt.} \end{aligned}$$

$$\begin{aligned} \text{The coefficient of friction} &= \frac{P}{R} \\ &= \frac{4.5}{6.5} \\ &= 0.69. \end{aligned}$$

Cant on Railway Curves

When a train travels along a curved track a force will be required towards the centre of curvature in order to provide the necessary change of momentum. If the track is level, as is usual in the case of tramways, the flanges on the wheels bear against the outer rail. In railway curves the outer rail is raised above the inner rail, and by this means, for a definite speed, all side thrust on the flanges may be avoided. The amount the outer rail is raised above the inner is called the *cant*. If the speed of the train exceeds that for which the cant was calculated the outer flange has to transmit some thrust; if the speed is less than that

for which the cant was calculated the inner flange will bear against the rail.

We will investigate this.

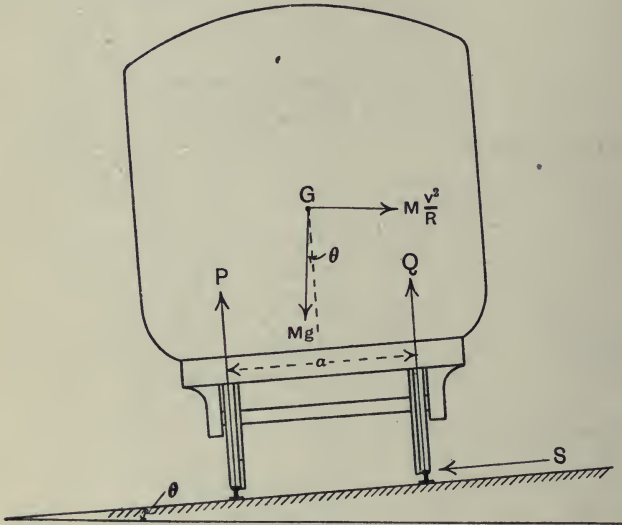

Fig. 82.

In fig. 82 let G be the centre of gravity, P and Q the normal thrusts on the wheels, a the mean distance between them, S the flange thrust, and v the speed in feet per second.

The acceleration towards the centre of curvature is $\frac{v^2}{R}$, where R is the radius of curvature. Put on a centrifugal force $\frac{Mv^2}{R}$, and we may then treat the problem as a statical one.

Resolving all the forces parallel and perpendicular to the track, we have :

Perpendicular to the track

$$P + Q - Mg \cos \theta - \frac{Mv^2}{R} \sin \theta = 0 \dots\dots\dots(1).$$

Parallel to the track

$$S + Mg \sin \theta - \frac{Mv^2}{R} \cos \theta = 0 \dots\dots\dots(2).$$

If S is zero, i.e. no side thrust on the flanges, we get from (2)

$$\tan \theta = \frac{v^2}{Rg}.$$

Let h = the cant, then $\tan \theta = \frac{h}{\sqrt{a^2 - h^2}} = \frac{h}{a}$, since h is small compared with a ,

$$\text{i.e. the cant} = \frac{av^2}{Rg}.$$

$$\begin{aligned} \text{Also } S &= M \left(\frac{v^2}{R} \cos \theta - g \sin \theta \right) \\ &= M \left(\frac{v^2}{R} - g \cdot \frac{h}{a} \right), \text{ if } \theta \text{ is small.} \end{aligned}$$

Example (4). Let $R = 660$ feet,
 $v = 40$ miles per hour

$$= \frac{88 \times 2}{3} \text{ feet per second,}$$

$a = 4$ feet $8\frac{1}{2}$ inches

$$= \frac{56 \cdot 5}{12} \text{ feet.}$$

The cant of the outer rail (h) for no side flange thrust

$$\begin{aligned} &= \frac{av^2}{Rg} \\ &= \frac{56 \cdot 5 \times 88^2 \times 4}{12 \times 660 \times 9 \times 32} \text{ feet} \\ &= 0 \cdot 765 \text{ foot} \\ &= 9\frac{1}{8} \text{ inches.} \end{aligned}$$

For a speed of 60 miles per hour, the side thrust of the flanges

$$\begin{aligned} &= M \left\{ \frac{88^2}{660} - 32 \times \frac{0 \cdot 765 \times 12}{56 \cdot 5} \right\} \\ &= M \{ 11 \cdot 7 - 5 \cdot 2 \} \text{ absolute units.} \end{aligned}$$

Or taking $M = 2240$ lbs. we get,

$$\begin{aligned} \text{The thrust per ton} &= \frac{2240 \times 6.5}{3.2} \\ &= 455 \text{ lbs. per ton.} \end{aligned}$$

Stress in the Rim of a Flywheel

Let us consider a flywheel in which the thickness of the rim is small compared with the mean radius, the flywheel consisting of a heavy rim connected to the hub by spokes.

Let ρ = the density of the metal of the wheel,

ω = the angular velocity of the wheel,

r = the mean radius, i.e. the radius of the centre of mass of a cross-section of the rim.

Take a small part of the rim subtending an angle $\delta\theta$ at the centre of the wheel (fig. 83).

Let a = the area of cross-section of the rim.

P = the total pull on the area at A or B in absolute units.

The mass of the element $AB = \rho ar \delta\theta$.

The acceleration towards the centre C

$$= \omega^2 r.$$

The centrifugal force on the element

$$= \rho \cdot a \cdot r^2 \cdot \omega^2 \cdot \delta\theta,$$

and acts at the centre of mass of the element.

This centrifugal force has to be balanced by the components of the forces P at A and B,

$$\therefore 2P \cdot \sin \frac{\delta\theta}{2} = \rho ar^2 \omega^2 \delta\theta.$$

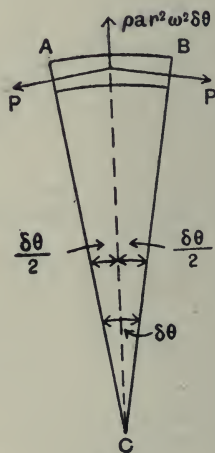

Fig. 83.

But since $\delta\theta$ is very small, we may write

$$\sin \frac{\delta\theta}{2} = \frac{\delta\theta}{2},$$

and we get

$$P \cdot \delta\theta = \rho ar^2 \omega^2 \delta\theta,$$

or

$$P = \rho ar^2 \omega^2.$$

Let f = the internal force per unit area at A or B, then

$$f = \frac{P}{a},$$

$$\therefore f = \rho r^2 \omega^2$$

$$= \rho v^2 \text{ absolute units,}$$

where v is the velocity of the centre of mass of a cross-section of the rim.

Example (5). *A flywheel is made of cast-iron which breaks when subjected to a pull of 10 tons per sq. inch. The external diameter is 8 feet and the thickness of the rim is 6 inches. What is the speed, in revolutions per minute, which will cause the flywheel to fly to pieces?*

The density of cast-iron = 470 lbs. per cubic foot.

Let N = the required speed.

Then $\omega = \frac{2\pi N}{60},$

and $v = \frac{2\pi N}{60} \times \frac{7.5}{2}$ feet per second.

The breaking stress = $10 \times 144 \times 2240 \times g$ pdls. per sq. foot.

Using the formula, $f = \rho v^2$, we have

$$10 \times 144 \times 2240 \times 32 = \frac{470 \times 4\pi^2 \times N^2 \times 7.5^2}{120^2},$$

or

$$N = \sqrt{\frac{120^2 \times 1440 \times 2240 \times 32}{470 \times 4 \times 3.14^2 \times 7.5^2}}$$

$$= 1195 \text{ revolutions per minute.}$$

Examples. Chapter V

1. A bucket of water is swung round in a vertical circle of 26 inches radius. What is the minimum speed of rotation if none of the water is spilled?

2. A particle is attached to the end of a string of length l , the other end of which is fixed, and moves as a conical pendulum making n revolutions per minute. Find the radius of the circular path which it describes.

A mass of 10 lbs. rotates as a conical pendulum at the end of an elastic string, of unstretched length 3 feet, and makes 40 revolutions per minute. If the string is stretched $\frac{1}{10}$ of its length by the weight of 1 lb. find the length of the string during the motion.

3. The spindle **EB** shewn in fig. 84 receives vertical support only at **E**, and is supported horizontally by collars at **A** and **B**. **DC** is a stiff arm rigidly attached to the spindle and carrying a weight at **C**. If **AB** is 8 inches, **DC** 10 inches, **D** midway between **A** and **B**, and the weight at **C** 10 lbs., find the horizontal forces at **A** and **B**.

Also find these forces when the spindle is rotating freely at 100 revolutions per minute, and determine the speed of rotation for which the reaction at **A** is zero.

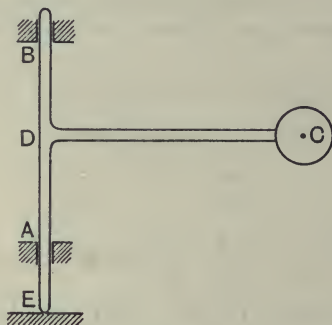

Fig. 84.

4. A particle of mud, sticking to the rim of a motor-car wheel travelling at 20 miles per hour, leaves it when situated at a point 30° behind the vertical line between the centre of the wheel and the road. Determine its velocity relative to the road, the mudguard, and the top of the wheel respectively.

To what forces and to what accelerations is the particle subjected before it leaves the wheel?

5. The governor of a steam engine, when making 210 revolutions per minute, takes up the position shewn on the sketch. If each ball weighs 1 lb., determine the weight W .

Supposing the speed of the engine to increase 2 per cent. before the throttle valve moved, what pull would the governor exert on the throttle valve lever?

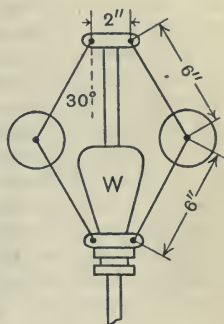

Fig. 85.

6. A steam roundabout revolves four times a minute. A wooden horse on the roundabout is suspended from the roof by an iron rod, and the centre of gravity of the horse and the man on it is at a distance of 20 feet from the axis about which the roundabout turns. Find the angle which the suspending rod makes with the vertical. Find also the horizontal displacement of the centre of gravity caused by centrifugal force, supposing this centre of gravity to be at a distance of 5 feet from the point of suspension.

7. A car weighing 30 cwt. is running at 15 miles per hour round a curve of 60 feet radius on a level road. What horizontal force perpendicular to the direction of motion must be exerted by the ground on the wheels of the car?

Assuming that the grip of the outer wheel is sufficient to prevent skidding, find at what speed the inner wheel will begin to lift off the ground. The width of the wheel base is 4 feet, the centre of gravity is 3 feet above the ground, and the given radius, 60 feet, is the radius of the circle midway between the tracks of the inner and outer wheels.

8. A motor-car track is designed to allow of cars running round a curve of 500 feet radius at 60 miles an hour without any frictional side pressure between the tyres and the road surface. Find the slope to which the curved part of the track must be banked up, and the side pressure produced per ton of car when the speed is 80 miles an hour.

9. A uniform disc is mounted on an axle which passes through its centre O . A mass of 25 lbs. is clamped to the disc, its centre of gravity being at a point A distant 2 feet from the centre O , and another mass of 40 lbs. is clamped with its centre of gravity at B distant 2.5 feet from O . The angle AOB is 120° . Find the resultant force on the axle due to the rotation of these masses, when the disc is making 200 revolutions per minute.

10. In the shaft governor, shewn diagrammatically in fig. 86, the ball levers are pivoted to a piece D which is fixed to the shaft F. For the position shewn, the pull in the springs connecting the balls is 150 lbs., and there is a force on the sleeve along the axis of the shaft equal to 115 lbs. In addition to this there is a maximum axial force on the sleeve due to friction of 10 lbs., which may act in either direction. Find the two extreme speeds at which the shaft may run without the sleeve of the governor moving along it. The length of AB is 6 inches; the length of BC is $3\frac{3}{4}$ inches; the balls are 12 inches apart and each weighs 15 lbs.

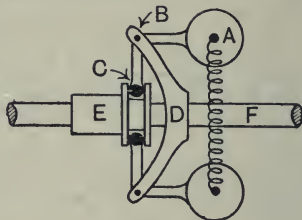

Fig. 86.

11. A cast-iron flywheel has a mean diameter of 4 feet. If the mean tensile stress in the rim is to be limited to 1000 lbs. per sq. inch find the maximum allowable speed of the wheel. A cubic foot of cast-iron weighs 470 lbs.

12. What is the side pressure between a train weighing 300 tons and the rails, when the train is going round a curve of 120 yards radius at 30 miles per hour, the rails being on the same level? What should be the cant for no side pressure with a speed of 30 miles per hour if the gauge is 4 feet $8\frac{1}{2}$ inches? With this cant, what will be the side pressure if the speed is 45 miles per hour?

13. A belt the mass of which is ρ lbs. per foot length passes round half the circumference of a pulley wheel, the speed of the belt being v feet per second. If T_1 and T_2 be the tensions in lbs. in the two sides of the belt, shew that, neglecting the weight of the belt, the total pull on the pulley is equal to

$$\left\{ T_1 + T_2 - \frac{2\rho v^2}{g} \right\} \text{ lbs.}$$

14. The wheel base of a steam tractor weighing 16 tons is 6 feet 10 inches across and the distance between the axles when they are parallel is 10 feet 10 inches. When going round a curve the distances between the points of contact of the wheels and the ground are 11 feet 4 inches for the outside pair, and 9 feet 4 inches for the inner pair. If the speed is 6 miles per hour, find the force tending to shift the tractor sideways.

15. A railway line over a bridge is curved, the radius of the curve being 400 yards. Find the side thrust on the bridge when a locomotive weighing 90 tons passes over at a speed of 30 miles per hour.

If the gauge is 4 ft. $8\frac{1}{2}$ inches, find how much the outer rail must be raised above the inner rail in order that there shall be no thrust on the flange.

16. A casting weighing 6 lbs. is bolted to the face-plate of a lathe, for the purpose of machining, in such a position that its centre of gravity is at a distance of 2 inches from the axis of the mandrel. The centrifugal force is to be balanced by two 3 lb. masses placed on two radii on opposite sides, and inclined at 45° to the diameter passing through the centre of gravity of the casting. Find how far from the centre the masses should be placed.

CHAPTER VI

WORK, POWER AND ENERGY

Work

WE have now to introduce some new physical quantities, and also another principle or law, mentioned in Chapter III, which is very far reaching in its applications and of particular importance to engineers.

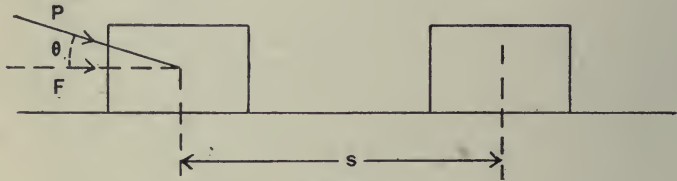

Fig. 87.

If a force acting on a body causes a displacement of it then the force is said to do *work*. Also, if a body is moved in the opposite direction to a force acting on it, work is said to be done against the force.

We see that there are two things necessary before work can be done, viz. **force** and **motion**.

The quantity of work done is measured by the product of the component of the force in the direction of the displacement, and the displacement.

For example, in the case shewn in fig. 87, if the force P moves the mass a distance s then,

$$\begin{aligned}\text{The work done} &= P \cos \theta \cdot s \\ &= F \cdot s,\end{aligned}$$

where F is the component of the force in the direction of motion.

The absolute unit of work in the F.P.S. system is the *foot-poundal*.
One foot-poundal is the work done by 1 poundal of force acting through a distance of 1 foot.

In the c.g.s. system the absolute unit is the *erg*.

One erg is the work done by 1 dyne of force acting through a distance of 1 centimetre.

$$1 \text{ joule} = 10^7 \text{ ergs.}$$

Frequently the gravitation unit is used, and we speak of the number of foot-lbs. of work done.

One ft.-lb. is the work done by a force equal to the weight of 1 lb. acting through a distance of 1 foot.

In the simple case shewn in fig. 87 we considered the force constant, but in many cases the force varies as the displacement increases. In such cases we may conveniently draw a *Force-Space* curve such as is shewn in fig. 88.

The work done for a small displacement δs will be represented by $AB \cdot \delta s$, i.e. the cross-shaded area, and the total work done is represented by the area under the force-space curve, shewn shaded vertically.

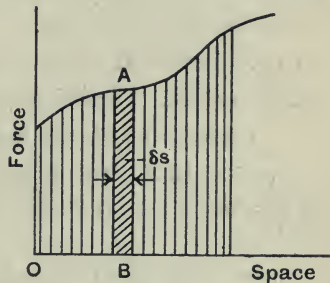

Fig. 88.

Or, we may find the *space-average* of the force (F) from the graph, or otherwise, and the work done will then be equal to $F \cdot s$, where s is the total displacement.

Note. This *space-average* of the force must not be confused with the *time-average* of the force which we used in applying the principle of momentum. In very few cases will the two averages have the same value.

Example (1). *The weight of the centre span of the Quebec bridge is 5400 tons. This span was raised into position through a vertical*

height of 150 feet by means of hydraulic jacks. Find the useful work done in foot-tons.

During lifting the vertical force downwards was constant and
 $= 5400 \times 2240$ lbs. wt.

The distance through which this force was overcome
 $= 150$ feet.

\therefore The work done $= 5400 \times 2240 \times 150$ ft.-lbs.
 $= 8.1 \times 10^5$ ft.-tons.

Power

Power is a name given to the time-rate of doing work, or is the amount of work done per unit time.

Absolute System of Units.

F.P.S. system. The unit of power is 1 foot-poundal per second.

C.G.S. system. The unit of power is 1 erg per second.

1 watt is 1 joule per second, i.e. 10^7 ergs per second.

Practical Unit. The British unit, most frequently employed for measuring power, is the **horse-power** originally introduced by Watt.

1 *horse-power* (H.P.) is a rate of working equal to 550 ft.-lbs. of work per second, or 33,000 ft.-lbs. of work per minute.

It may be noted that power multiplied by time gives us work done, or

$$W = H \cdot t,$$

where W = the work done, H = the power, and t = the time.

In dealing with heat engines we frequently use this as a basis for a large unit of work called the

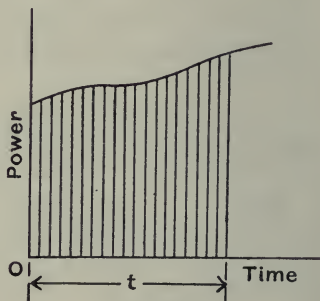

Fig. 89.

horse-power-hour. This is the work done by an agent, working at 1 horse-power, in one hour.

i.e. 1 horse-power-hour = $33,000 \times 60$ ft.-lbs.

If the power is varying we may find the work done by drawing a *power-time* curve, fig. 89.

The work done in time t is obviously represented by the shaded area under the curve.

Example (2). *An electric crane raises a load of 3 tons through a vertical distance of 20 feet, in 12 seconds, at a uniform speed. If 23 per cent. of the power supplied is wasted in friction, what is the horse-power which has to be supplied to the motor?*

The work done in 12 seconds = $3 \times 2240 \times 20$ ft.-lbs.

The work done per second = $\frac{3 \times 2240 \times 20}{12}$ ft.-lbs.

\therefore The horse-power used in raising the load

$$= \frac{3 \times 2240 \times 20}{12 \times 550}$$

$$= 20.4 \text{ H.P.}$$

Let H = the horse-power supplied to the motor.

$$H = 20.4 + \frac{2.3}{100} H,$$

i.e.
$$H = \frac{20.4}{0.77}$$

$$= 26.5 \text{ H.P.}$$

Energy

The energy of a body is its capacity to do work.

It is measured by the amount of work which can be done, and therefore has the same units as work. So long as we deal with the energy of a body, or system of bodies, and not with energy

in the abstract, for mechanical problems we may divide energy into two classes:

- (1) **Potential Energy.**
- (2) **Kinetic Energy.**

The **Potential Energy** of a body is the energy a body possesses in virtue of its *position*.

The commonest case is the energy due to a body's position relative to the earth.

Suppose we have a mass of M lbs. raised a distance h feet above the ground, then if we allow the body to fall the force of gravity, Mg absolute units, will act through the distance h , and the work it does will be equal to Mgh absolute units.

Mgh is a measure of the potential energy, in absolute units, of a mass M raised a height h .

Another example of potential energy is afforded by a mass of iron which is in the neighbourhood of a fixed magnet. If there is no resisting force such as friction, the mass of iron, if freed, will be moved to the magnet. Therefore, when separated from the magnet, it possesses Potential Energy due to its position. Again, a helical spring or elastic body which is stretched, has potential energy stored up in it, and this can be got out when the spring or body is allowed to return to its normal length.

The **Kinetic Energy** of a body is the energy it possesses in virtue of its *motion*.

That there is energy possessed by a body in motion is easily seen when we realise that, in order to stop a body which is moving, we shall have to exert a force, and work will be done against this force while the body is being brought to rest.

We must find an expression to represent the quantity of kinetic energy possessed by a mass M say, moving with a speed v .

Suppose we apply a constant force F , in a direction opposite to

that of the motion, and that this force stops the body in a distance s .

The kinetic energy of the body
 = the work done against the force
 = $F \cdot s$.

Now this constant force will produce a uniform rate of change of speed given by $\frac{v}{t}$, where t is the time taken to come to rest.

$$\therefore \text{We have} \quad F = \frac{Mv}{t}.$$

Also, the time-average of the speed will be $\frac{v}{2}$,

$$\therefore s = \frac{v}{2} \cdot t.$$

The kinetic energy = $F \cdot s$

$$\begin{aligned} &= \frac{Mv}{t} \times \frac{v}{2} \cdot t \\ &= \frac{1}{2} Mv^2. \end{aligned}$$

This is the expression required for the kinetic energy.

The kinetic energy in absolute units is equal to one-half the product of the mass and the square of the speed.

Suppose now the force is not constant. Let it be F when the velocity is u , and suppose that it produces a small decrease of velocity δu , and that the distance moved is δs . Then

$$\begin{aligned} F \cdot \delta s &= \text{the change of kinetic energy for the distance } \delta s \\ &= \delta \left(\frac{1}{2} Mv^2 \right), \end{aligned}$$

$$\text{or} \quad F = \frac{\delta \left(\frac{1}{2} Mv^2 \right)}{\delta s}.$$

This is only true when δs is made indefinitely small, as F may vary over the distance δs . When δs is made indefinitely small we get

$$F = \frac{d \left(\frac{1}{2} Mv^2 \right)}{ds},$$

or, the force for any position of the body is equal to the rate of change of the kinetic energy with respect to the distance.

If F is the space-average of the force, and s is the total distance,

$$F \cdot s = \text{the total change of kinetic energy.}$$

Gravitation Units.

The kinetic energy = $\frac{1}{2} \frac{Mv^2}{g}$, where g is the numerical value of the acceleration due to gravity.

If we use this unit, it is clear that in equating the work done to the kinetic energy the force must be measured in Gravitation Units.

Example (3). *A motor-car weighing 18 cwt. and travelling at 10 miles per hour is brought to rest in 20 feet by the application of its brake. Find the space-average of its retarding force.*

The kinetic energy of the car

$$\begin{aligned} &= \frac{1}{2} mv^2 \text{ abs. units} \\ &= \frac{1}{2} \times 18 \times 112 \times \left(\frac{88}{60} \times 10\right)^2 \text{ ft.-pdls.} \\ &= 2 \cdot 17 \times 10^5 \text{ ft.-pdls.} \end{aligned}$$

Let F be the space-average of the retarding force in abs. units.

The work done against this force F by the car is equal to $F \cdot s$, i.e. $F \times 20$ ft.-pdls.

$$\therefore F \times 20 = 2 \cdot 17 \times 10^5,$$

$$\begin{aligned} \text{i.e.} \quad F &= \frac{2 \cdot 17 \times 10^5}{20} \text{ pdls.} \\ &= \frac{2 \cdot 17 \times 10^5}{20 \times 32} \text{ lbs.} \\ &= 340 \text{ lbs.} \end{aligned}$$

Comparison between Momentum and Kinetic Energy

If a constant force F acts on a body of mass M and produces a change of velocity from u to v , in a distance s , and a time t , then,

$$F \times t = \text{the change of momentum} = (Mv - Mu),$$

$$F \times s = \text{the change of kinetic energy} = \left(\frac{1}{2} Mv^2 - \frac{1}{2} Mu^2\right).$$

If the force is varying, for estimating the change of **momentum** we must use the **time-average** of the force.

For estimating the change of **kinetic energy** we must use the **space-average** of the force.

Example (4). *In the problem on p. 69 we had the accelerating force-time curve for the first 11.1 seconds after the starting of a train.*

Find the time-average and the space-average of the force.

The force increased uniformly with the time and at the end of 11.1 seconds was 3.96 tons wt.

$$\begin{aligned} \therefore \text{The time-average of the force} &= \frac{3.96}{2} \\ &= 1.98 \text{ tons wt.} \end{aligned}$$

To find the space-average of the force we want to know the distance moved. This we can obtain from the velocity-time curve shewn on p. 70. The area under the curve gives the distance. By counting squares we find there are 128.

$$\therefore \text{The distance} = 128 \times 0.1 \times 0.5 = 6.4 \text{ feet.}$$

The velocity at the end of the time = 1.72 feet per second.

Equating the work done to the kinetic energy generated, we have

$F \cdot s = \frac{1}{2} Mv^2$, where F is the space-average of the force.

$$F \times 6.4 = \frac{1}{2} \times 400 \times 1.72^2.$$

$$\begin{aligned} \therefore F &= \frac{400 \times 1.72^2}{2 \times 6.4} \\ &= \frac{400 \times 1.72^2}{2 \times 6.4 \times 32} \text{ tons wt.} \\ &= 2.89 \text{ tons wt.} \end{aligned}$$

We thus have,

Time-average of the force = 1.98 tons wt.

Space-average of the force = 2.89 tons wt.

It should be noted that energy is a *scalar* quantity and not a vector quantity. The force in the case of potential energy and the velocity in the case of kinetic energy will have definite directions, but this does not affect the energies. We have already defined the energy of a body merely as its capacity for doing work. By suitable means we can arrange for the direction of the work done by a given quantity of energy to be what we wish. For example in the case shewn in fig. 90, we may use the potential energy of the mass m in doing work against a resistance F acting on M .

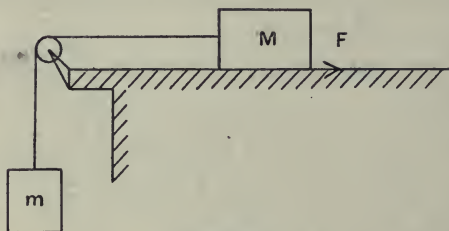

Fig. 90.

Or again, take the case of a motor-car going round a corner at a constant speed. In order to change the momentum we know we must have a force acting towards the centre of rotation for a given time, but this force does no work since it always acts at right angles to the motion, and the kinetic energy remains constant although the direction is changing.

In dealing then with energy, in order to obtain the total we add the quantities algebraically and not vectorially.

Conservation of Energy

So far we have only been dealing with *two* forms of energy, *potential* and *kinetic*, but, apart from these mechanical forms, there are, in nature, several forms of energy, heat, light, electrical, chemical and so on.

Now the various forms of energy can be converted one into another. When a piece of iron is hammered on an anvil the

potential energy of the hammer is first changed into kinetic energy. This is changed into heat when the hammer strikes the iron. In the case of a steam engine driving an electrical generator we have a case of heat energy of the steam being used to produce electrical energy. The heat of the steam is produced from chemical energy in the coal.

In all these conversions of energy from one form to another which are either arranged by man, or occur in nature, we assume that there is no net loss or gain of energy. When a definite quantity of one form of energy, A say, is used up in producing another form of energy, B say, the quantity of B produced is exactly equal to the quantity of A which has disappeared. To put it in another way, man finds he cannot create or destroy energy and he believes that the Deity does not do so.

The whole of physical science rests on this *principle of the conservation of energy*. Whenever physical phenomena have been discovered, which appeared at first to violate this principle, further experiments have always shewn, either an error of observation, or that a form of energy has been discovered which, up to that time, was unknown to man. It seems most probable that there are still forms of energy which exist unknown to man, or which man cannot make use of by converting them to other forms.

Now in mechanical problems we shall always be dealing with a definite body, or system of bodies, and generally we need only concern ourselves with the mechanical forms of energy.

In such cases the body or system of bodies may have the total energy altered by work being done on or by the body or system.

We may express this as follows :

Whenever a body or system of bodies has its energy changed the increase of energy is exactly equal to the net work done on the system by the external forces. Or,

Work put in – work got out = Gain of energy.

If the left-hand side is negative the gain of energy will be negative, i.e. there will be a loss of energy in the body or system.

Example (5). *A shell weighing 260 lbs., which did not explode, was found to have penetrated the ground in a certain place a distance of 8 feet in the direction of impact. The striking velocity was 820 feet per second. What was the space-average resistance to penetration of the ground? Neglect the energy due to rotation.*

If the velocity of the shell had been 1000 feet per second at striking, how far would it have penetrated?

Let R = the average resistance to penetration in lbs. wt.

We may neglect the change of potential energy of the shell and may say,

The work done against the resistance of the ground = the loss of kinetic energy of the shell, i.e.

$$R \times g \times 8 = \frac{1}{2} \times 260 \times 820^2.$$

$$\therefore R = \frac{260 \times 820^2}{2 \times 32 \times 8} \text{ lbs. wt.}$$

$$= 342,000 \text{ lbs. wt.}$$

$$= 153 \text{ tons wt.}$$

Let x = the distance of penetration for a striking velocity of 1000 feet per second.

Then, since R is constant,

$$\frac{x}{8} = \frac{1000^2}{820^2},$$

$$\therefore x = 11.9 \text{ feet.}$$

Example (6). *A spring is such that it extends $\frac{1}{2}$ inch for a pull of 1 lb. wt. A mass of 4 lbs. is suspended by the spring, being fixed to the end, and is pulled down until the spring is extended a total distance of 5 inches. If the mass is suddenly let go, how high will it rise and what will be its maximum velocity?*

The mass of the spring may be neglected.

The energy stored in the spring, when stretched, is equal to the work done in stretching it.

The pull-extension curve will be a straight line as shewn in fig. 91.

For 5 inches extension the pull of the spring = 10 lbs. wt.

The energy in the spring initially

$$= \text{area OAB}$$

$$= \frac{10 \times 5}{2 \times 12} \text{ ft.-lbs.}$$

Let h = the maximum height in inches which the mass rises.

When the mass is at its maximum height, the spring is extended $(5 - h)$ inches.

The pull of the spring in this position

$$= 2(5 - h) \text{ lbs. wt.}$$

The energy stored in the spring in this position

$$= \frac{2(5 - h)^2}{2 \times 12} \text{ ft.-lbs.}$$

The gain of potential energy of the mass = $\frac{4h}{12}$ ft.-lbs.

The gain of potential energy of the mass = the loss of strain energy of the spring.

$$\therefore \frac{4h}{12} = \frac{10 \times 5}{2 \times 12} - \frac{2(5 - h)^2}{2 \times 12},$$

or

$$h^2 - 6h = 0,$$

i.e.

$$h = 0, \text{ or } h = 6 \text{ inches.}$$

It is obvious that the spring will be in compression.

To find the maximum velocity of the mass. The velocity will continue to increase so long as the pull of the spring is greater than the weight of the mass, i.e. until the spring's extension is reduced to 2 inches. We have then,

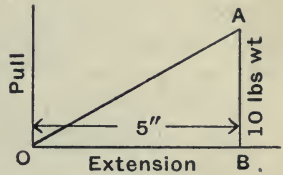
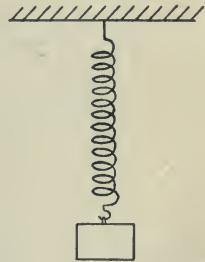

Fig. 91.

The gain of potential and kinetic energy of the mass = the loss of strain energy in the spring,

or, using absolute units,

$$\frac{4 \times 3 \times 32}{12} + \frac{1}{2} \times 4v^2 = \left(\frac{10 \times 5}{2 \times 12} - \frac{2 \times 2^2}{2 \times 12} \right) 32,$$

i.e. $32 + 2v^2 = \frac{4 \frac{2}{4}}{2} \times 32,$

$$\therefore v^2 = \sqrt{\frac{18 \times 32}{24 \times 2}},$$

or $v = 3.46$ feet per second.

Example (7). *A railway siding is level for the first 50 yards, and then rises at a slope of $\frac{1}{40}$. A wagon weighing 10 tons is shunted on to the siding with a velocity of 18 miles per hour, and is observed to reach the foot of the incline in 6 seconds. If the resisting force due to friction is constant, what is its magnitude?*

How far up the incline will the wagon travel before coming to rest?

Let v = the velocity at the foot of the incline in feet per second.
The average velocity for the first 6 seconds

$$\begin{aligned} & \frac{18 \times 88}{60} + v \\ &= \frac{\quad}{2}, \end{aligned}$$

$$\therefore \frac{26.4 + v}{2} \times 6 = 150,$$

i.e. $v = 50 - 26.4$
 $= 23.6$ feet per second.

Let F = the force due to friction in abs. units.

By the 2nd law of momentum we have,

$$\begin{aligned} F &= \frac{m(v_1 - v_0)}{t} \\ &= \frac{10 \times (26.4 - 23.6)}{6} \text{ abs. units} \\ &= \frac{10 \times 2.8}{6 \times 32} \text{ tons wt.} \\ &= 0.146 \text{ tons wt.} \end{aligned}$$

The total retarding force up the incline
 $= 0.146 + \frac{1}{40} \times 10$ (approx.)
 $= 0.396$ tons wt.

Again, by the 2nd law of momentum for the incline,

$$0.396 \times 32 = 10 \times \frac{23.6}{t},$$

where t is the time taken to come to rest, i.e.

$$t = \frac{10 \times 23.6}{0.396 \times 32} \text{ seconds.}$$

The average velocity $= \frac{23.6}{2}$ feet per second.

\therefore The distance up the incline $= \frac{23.6}{2} \times \frac{236}{32 \times 0.396}$
 $= 220$ feet.

Or, we may use the energy principle.

The work done against friction = the loss of energy.

For the first part of motion,

$$\begin{aligned} F \times 150 &= \frac{1}{2} \times 10 (26.4^2 - 23.6^2), \\ \therefore F &= \frac{5 (26.4^2 - 23.6^2)}{150} \text{ abs. units} \\ &= \frac{5 \times 50 \times 2.8}{32 \times 150} \text{ tons wt.} \\ &= 0.146 \text{ tons wt.} \end{aligned}$$

For the motion up the incline, let s = the distance in feet.

The gain of potential energy $= \frac{10 \times s}{40}$ (nearly)
 $= \frac{s}{4}$ foot-tons.

$$\begin{aligned} \therefore 0.146 \times g \times s &= \frac{1}{2} 10 \times 23.6^2 - \frac{s}{4} \times g, \\ \therefore s &= \frac{5 \times 23.6^2}{0.396 \times 32} \\ &= 220 \text{ feet.} \end{aligned}$$

Example (8). 200 gallons of water are to be pumped per minute through a 3-inch pipe up a height of 40 feet. The useful horse-power of the pump is 42 per cent. of the horse-power supplied, and the estimated loss due to friction in the pipe is equivalent to an additional height of 16 feet. What horse-power will have to be supplied to the pump?

1 cubic foot contains $6\frac{1}{4}$ gallons.

1 gallon of water weighs 10 lbs.

Let v = the velocity of delivery in feet per second, and d = the diameter of the pipe in feet.

$$\text{Then,} \quad \frac{\pi d^2}{4} \times v = \frac{200}{60} \times \frac{1}{6\frac{1}{4}},$$

$$\begin{aligned} \text{i.e.} \quad v &= \frac{200 \times 4 \times 16}{60 \times 6 \cdot 25 \times \pi} \\ &= 10 \cdot 85 \text{ feet per second.} \end{aligned}$$

$$\begin{aligned} \text{The mass of water delivered per second} &= \frac{2000}{60} \text{ lbs.} \\ &= 33 \cdot 3 \text{ lbs.} \end{aligned}$$

$$\text{The potential energy supplied per second} = 33 \cdot 3 \times 40 \text{ ft.-lbs.}$$

$$\text{The work done against friction per second} = 33 \cdot 3 \times 16 \text{ ft.-lbs.}$$

The kinetic energy supplied per second

$$= \frac{1}{2} \frac{33 \cdot 3 \times 10 \cdot 85^2}{32} \text{ ft.-lbs.}$$

The total energy supplied per second

$$\begin{aligned} &= 33 \cdot 3 \left\{ 40 + 16 + \frac{10 \cdot 85^2}{64} \right\} \text{ ft.-lbs.} \\ &= 33 \cdot 3 \{ 40 + 16 + 1 \cdot 84 \} \\ &= 1930 \text{ ft.-lbs.} \end{aligned}$$

$$\text{The horse-power given to the water} = \frac{1930}{550}.$$

$$\begin{aligned} \therefore \text{The horse-power to be supplied to the pump} &= \frac{1930}{550} \times \frac{100}{42} \\ &= 8 \cdot 35. \end{aligned}$$

In applying the principle of conservation of energy to mechanical problems, we must be careful to see that we are not getting energy developed which we are neglecting. For example, take the case of an impact between two bodies where we are getting a sudden change of momentum. Most frequently in such cases we shall get energy dissipated in the form of heat. Work may actually be done in damaging the bodies which impinge, or vibrations may be set up by the impact, the energy of which is ultimately changed to heat. In such cases we cannot apply the principle stated above, but we can still apply the principle of conservation of momentum.

Consider the example of two trucks on p. 79.

Before impact the total kinetic energy

$$= \left(\frac{1}{2} \times 12 \times 36 + \frac{1}{2} \times 10 \times 4 \right) \frac{88^2}{60^2 \times 32} \text{ ft.-tons}$$

$$= 15.85 \text{ ft.-tons.}$$

After impact the total kinetic energy

$$= \frac{1}{2} \times 22 \times 4.17^2 \times \frac{88^2}{60^2 \times 32}$$

$$= 12.9 \text{ ft.-tons.}$$

$$\therefore \text{The energy lost during impact} = (15.85 - 12.9)$$

$$= 2.95 \text{ ft.-tons.}$$

Example (9). *In a ballistic pendulum, for estimating the velocity of rifle bullets, a block of wood weighing 10 lbs. was suspended by two parallel strings as shewn in fig. 92. When a bullet weighing 0.4 oz. was fired into the block in a horizontal direction, passing through the centre of gravity of the block, it was observed that the block rose 6.95 inches. Find the velocity of the bullet.*

In this case we shall get a considerable quantity of heat developed. We may assume that the block does not appreciably move until the bullet has penetrated its greatest distance.

Let v = the initial velocity of the bullet in feet per second, and

v = the velocity with which the block begins to move in feet per second.

The total momentum of the bullet and the block in a horizontal direction must remain constant, since there is no resultant force in that direction.

$$\therefore \frac{0.4}{16} v = \left(10 + \frac{0.4}{16}\right) v,$$

i.e. $v = 10.025 \times 40v,$

or $v = 401v \dots\dots\dots(1).$

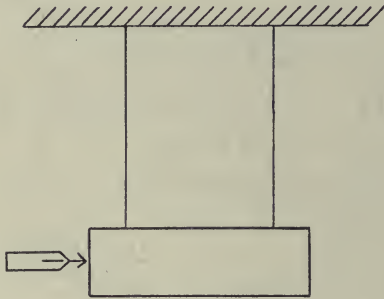

Fig. 92.

The block and the bullet now swing forward, and all their kinetic energy is changed to potential energy when they reach their highest point.

$$\therefore \frac{1}{2} (10.025) v^2 = 10.025 \times 32 \times \frac{6.95}{12} \dots\dots\dots(2),$$

i.e. $v^2 = \frac{64 \times 6.95}{12},$

or $v = 6.06$ feet per second.

\therefore from (1),

The velocity of the bullet = 401×6.06
 = 2430 feet per second.

The fraction of the initial energy dissipated in heat

$$\begin{aligned}
 &= \frac{\frac{1}{2} \left(\frac{0.4}{16} \right) \times 2430^2 - \frac{1}{2} (10.025) \times 6.06^2}{\frac{1}{2} \left(\frac{0.4}{16} \right) \times 2430^2} \\
 &= 1 - \frac{10.025 \times 40 \times 6.06^2}{2430^2} \\
 &= 0.9975.
 \end{aligned}$$

Example (10). Loads M , m , and P are suspended by a string which passes over a light frictionless pulley as shewn in fig. 93. A ring fixed at A is large enough for m to pass through but stops P . The string connected to m passes through a hole in P . M is greater than m and less than $P + m$. Shew that, if the masses start from rest in the position shewn in the figure, after the mass m has passed twice through the ring the system will, for the instant, come to rest again with P at a height $\left(\frac{M + m}{P + m + M} \right)^2$ above the ring.

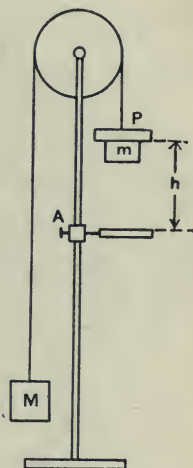

Fig. 93.

Let h' be the required height above the ring when the system is again at rest.

The total energy lost is all potential and is equal to

$$(P + m - M) g (h - h').$$

This energy is lost due to the two impacts at the ring.

On the first passage through the ring the velocity v is given by

$$g (P + m - M) h = \left(\frac{P + m + M}{2} \right) v^2 \dots\dots\dots (1).$$

When P strikes the ring the energy lost

$$= \frac{1}{2} P v^2 \dots\dots\dots (2).$$

On the return journey, just before m strikes P , the velocity of m will again be v , since there is no loss of energy.

Let T = the impulse in the string when P is jerked into motion, and let u = the velocity after the jerk.

Then for P and m ,

$$T = (P + m)u - mv,$$

and for M , $T = Mv - Mu$.

Eliminating T , we get,

$$u = \left(\frac{M + m}{P + m + M} \right) v \dots\dots\dots(3).$$

The energy lost

$$= \frac{1}{2} (M + m) v^2 - \frac{1}{2} (M + m + P) u^2 \dots\dots\dots(4).$$

The total energy lost from (2) and (4)

$$\begin{aligned} &= \frac{1}{2} (P + m + M) (v^2 - u^2) \\ &= (P + m - M) g (h - h'). \end{aligned}$$

Since the masses came to rest at a height h' ,

$$(P + m - M) gh' = (P + m + M) \frac{u^2}{2}.$$

From equations (3) and (1),

$$gh' = \frac{(M + m)^2 v^2}{2 (P + m + M) (P + m - M)}.$$

$$\therefore h' = \left(\frac{M + m}{P + M + m} \right)^2 h.$$

Energy and Momentum Principles

It should be noted that since in defining work and mechanical energy we have introduced no new physical facts, but merely *definitions* in terms of physical quantities already measurable, we cannot really obtain any new results by the application of the principle of the conservation of energy in the restricted form given above. The same results can always be obtained by the principle of momentum, but frequently the labour may be very considerably reduced by using the principle of energy.

This of course does not apply to the general principle of conservation of energy where all forms of energy are taken into account. We will emphasize the two principles as applied to translation by restating them.

(1) "In any system the total momentum remains constant unless the system is acted upon by external forces."

If external forces are acting, then the resultant change of momentum is equal to the resultant external force multiplied by the time during which it acts.

(2) "In any system the total energy remains constant unless the system is acted upon by external forces."

If external forces are acting, then the total change of energy is equal to the resultant external force multiplied by the distance moved by the point of application in the direction of the force.

Kinetic Energy due to rotation about a fixed axis

Bearing in mind that kinetic energy is a scalar quantity, it is easy to estimate the kinetic energy of a body due to rotation.

Suppose a body is rotating about a fixed axis O with an angular velocity ω radians per second. Consider a small particle of mass m at a distance r from the axis. This has a speed ωr , and its kinetic energy

$$= \frac{m\omega^2 r^2}{2} \quad \frac{1}{2} m v^2$$

\therefore For the whole body the kinetic energy $= \sum \frac{1}{2} m\omega^2 r^2$, the summation being effected for all the particles of the body, i.e. The kinetic energy $= \frac{1}{2} \omega^2 \sum mr^2$
 $= \frac{1}{2} \mathbf{I} \cdot \omega^2$,

where \mathbf{I} equals the moment of inertia of the body about the axis through O .

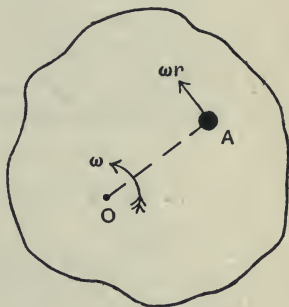

Fig. 94.

Work done by a couple or torque

Let a body, pivoted about a fixed axis, be subjected to a turning moment or torque T . Consider a particle at A , distant r from the axis, and let f be the force acting on the particle in a direction perpendicular to AO . The component of force acting on A in the direction AO will do no work, since there is no motion towards or away from O . If the body rotate through a small angle $\delta\theta$, the work done on the particle $= f \cdot r \delta\theta$.

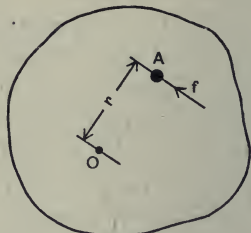

Fig. 95.

For the whole body we shall have,

$$\begin{aligned} \text{The work done} &= \sum f r \delta\theta \\ &= \delta\theta \times \sum f r, \end{aligned}$$

since $\delta\theta$ is the same for all the particles.

Now $\sum f r$ = the algebraic sum of the moments of all the forces, external and internal, about the axis through O . The internal forces mutually balance.

$\therefore \sum f r$ = the algebraic sum of the moments of all the external forces about the axis through O , i.e.

$$\sum f r = \text{the torque.}$$

$$\therefore \text{The work done} = T \delta\theta.$$

Constant Torque.

If the torque is constant then the work done for an angle of rotation $\theta = T\theta$.

Varying Torque.

If the torque be a varying one, the work done may be obtained from the curve connecting the torque and angle turned through.

$$\text{The work done} = \sum T \delta\theta$$

$$= \text{The area under the torque-angle curve.}$$

Energy principle applied to rotation

The energy principle applied to rotation may be stated thus,

The work done by the resultant torque = the gain of rotational kinetic energy.

Example (11). *A clock spring is such that the turning moment required to wind it up varies as the angle of wind. The turning moment exerted at the end of the first revolution equals 3 inch-lbs. Find the work done in making the third revolution.*

The torque-angle curve will be a straight line as shewn in fig. 96.

Let $OC = 4\pi$ radians, and $OD = 6\pi$ radians.

The work done during the third revolution

$$= \text{area ABDC}$$

$$= \left(\frac{AC + BD}{2} \right) \times CD.$$

$$AC = 6 \text{ inch-lbs. } BD = 9 \text{ inch-lbs.}$$

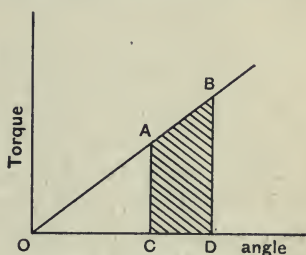

Fig. 96.

$$\therefore \text{The work done} = \frac{6 + 9}{2} \times 2\pi$$

$$= 15\pi \text{ inch-lbs.}$$

$$= 3.93 \text{ foot-lbs.}$$

Example (12). *In a De Laval Steam Turbine giving 5 horse-power the rotor runs at 30,000 revolutions per minute. The vanes, on which the steam acts, are at a mean distance from the axis of $3\frac{1}{2}$ inches. Neglecting frictional losses, find the tangential force exerted by the steam on the rotor.*

Let P = the force in lbs. weight acting tangentially on the rotor.

$$\text{The torque on the rotor} = \frac{P \times 3.5}{12} \text{ lbs. ft.}$$

$$\begin{aligned} \text{The angle turned through per minute} \\ = 30,000 \times 2\pi \text{ radians.} \end{aligned}$$

$$\begin{aligned} \text{The work done per minute by the steam} \\ = \frac{P \times 3.5 \times 30,000 \times 2\pi}{12} \text{ ft.-lbs.} \\ = \text{Horse-power} \times 33,000. \end{aligned}$$

$$\therefore P \times 3.5 \times 5000 \times \pi = 5 \times 33,000,$$

$$\begin{aligned} \text{or} \quad P &= \frac{33}{3.5 \times \pi} \\ &= 3 \text{ lbs. wt.} \end{aligned}$$

Example (13). *A uniform trap-door, 2 feet by 2 feet, and weighing 20 lbs., falls from the vertical position and strikes the floor only along the edge opposite the hinges. Find the angular velocity of the door just before it strikes the floor, and the magnitude of the blow on the edge.*

(1) To find the angular velocity we may equate the loss of potential energy and the gain of kinetic energy.

Since the centre of gravity falls 1 foot, the loss of potential energy

$$= 20 \times g \text{ ft.-pdl.}$$

The moment of inertia about an axis through the hinges

$$\begin{aligned} &= 20 \left\{ \frac{1}{3} + 1 \right\} \\ &= \frac{80}{3} \text{ lbs. ft.}^2 \end{aligned}$$

The gain of kinetic energy = $\frac{1}{2} \times \frac{80}{3} \times \omega^2$, where ω is the angular velocity just before striking the floor.

$$\therefore \frac{40}{3} \omega^2 = 20 \times 32,$$

or,

$$\begin{aligned} \omega &= \sqrt{48} \\ &= 6.9 \text{ radians per second.} \end{aligned}$$

(2) To find the impulse on the edge, we have, the impulsive torque equals the change of angular momentum.

Let P = the impulse in absolute units.

Then $P \times 2$ = the impulsive torque.

$$\therefore P \times 2 = \frac{80}{3} \times 6.9,$$

or,

$$P = 92 \text{ abs. units.}$$

Example (14). *The turning moment on the crank shaft of an engine for different positions of the crank is given in the figure below. The scales are such that 1 inch = 150 lbs. ft. of turning moment, and 1 inch = 135 degrees of angle turned through by the crank. The mean speed of the engine is 150 revolutions per minute, and the moment of inertia of the flywheel is 944 lbs. ft.² units.*

If the resisting moment is constant, find approximately the greatest fluctuation of speed.

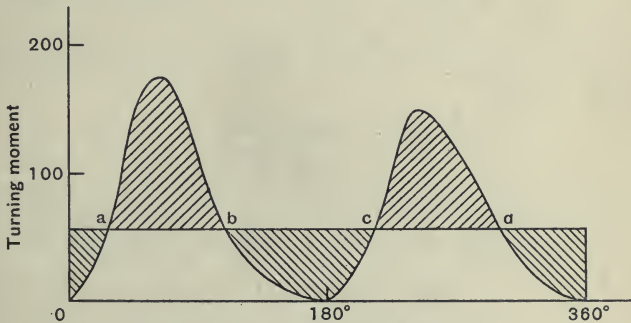

Fig. 97.

The area under the curve gives the work done per revolution.

This area = 1.16 square inches.

$$\begin{aligned} 1 \text{ sq. in.} &= \frac{150 \times 135}{180} \pi \text{ ft.-lbs.} \\ &= 112\pi \text{ ft.-lbs.} \end{aligned}$$

The work done per revolution = $112 \times 1.16\pi = 130\pi$ ft.-lbs.

If T is the resisting torque, we have

$$\begin{aligned} T \times 2\pi &= 130\pi, \\ \therefore T &= 65 \text{ lbs. ft.} \end{aligned}$$

This torque is represented in fig. 97 by the line $abcd$.

Now from a to b , since the turning moment is greater than the resisting moment, there will be a resultant moment increasing the speed of the engine. The gain of kinetic energy will be represented by the shaded area above ab .

Similarly from b to c the speed will be decreasing, and the loss of kinetic energy will be given by the shaded area below bc .

From c to d the speed will again be increasing, the gain of kinetic energy being given by the shaded area above cd .

From d to a the speed will be decreasing, the loss of kinetic energy being given by the shaded area below da .

The greatest change of energy will be given by the greatest of the four shaded areas. By trial it will be found that the area above ab is the greatest.

$$\begin{aligned} \text{This area} &= 0.227 \text{ square inch} \\ &= 25.5\pi \text{ ft.-lbs.} \end{aligned}$$

Let ω_1 be the angular velocity at a , and ω_2 be the angular velocity at b . If I is the moment of inertia of the flywheel, we have

$$\frac{1}{2} I\omega_2^2 - \frac{1}{2} I\omega_1^2 = 25.5\pi \times g,$$

i.e.,

$$(\omega_2^2 - \omega_1^2) = \frac{51 \times \pi \times 32}{944} \dots\dots\dots(1).$$

Now we do not exactly know the mean speed in terms of ω_2 and ω_1 since the speed is not changing uniformly. We may, however, as a close approximation, near enough for practical purposes, assume that $\frac{\omega_2 + \omega_1}{2}$ is equal to the mean speed, i.e.

$$\frac{\omega_2 + \omega_1}{2} = \frac{2\pi \times 150}{60}.$$

From equation (1) we get

$$(\omega_2 - \omega_1)(\omega_2 + \omega_1) = \frac{51 \times \pi \times 32}{944},$$

i.e. $(\omega_2 - \omega_1) = \frac{51 \times \pi \times 32 \times 60}{944 \times 4\pi \times 150}$ radians per second.

Or, if N_1 and N_2 are the extreme limits of speed in revolutions per minute,

$$\begin{aligned} (N_2 - N_1) &= \frac{(\omega_2 - \omega_1) \times 60}{2\pi} \\ &= \frac{51 \times 16 \times 60 \times 60}{944 \times 4\pi \times 150} \\ &= 1.65 \text{ revolutions per minute.} \end{aligned}$$

The percentage fluctuation in speed

$$\begin{aligned} &= \frac{1.65}{150} \times 100 \\ &= 1.1 \text{ per cent.} \end{aligned}$$

Example (15). *Taking the figures given in the example on p. 100, find the energy lost in heat due to the impact of the two wheels.*

The kinetic energy before impact

$$= \frac{1}{2} \times 4 \times \left(\frac{2\pi \times 500}{60} \right)^2 \text{ ft.-pdl.s.}$$

The kinetic energy after impact

$$\begin{aligned}
 &= \frac{1}{2} \times \frac{4\pi^2}{3600} \times (4 \times 253^2 + 2 \times 354^2) \\
 &= \frac{1}{2} \times \frac{4\pi^2}{3600} \times 5.07 \times 10^5 \text{ ft.-pdl.}
 \end{aligned}$$

\(\therefore\) The energy lost in heat

$$\begin{aligned}
 &= \frac{1}{2} \times \frac{4\pi^2}{3600} \times \{10^6 - 0.507 \times 10^6\} \times \frac{1}{32} \text{ ft.-lbs.} \\
 &= \frac{\pi^2 \times 10^3 \times 4.93}{9 \times 64} \\
 &= 84.3 \text{ ft.-lbs.}
 \end{aligned}$$

Examples. Chapter VI

1. A cage weighing 3 tons is supported by a steel rope which weighs 20 lbs. per yard, and is being lifted at a uniform speed. How much work is done when the free length of the rope is shortened from 1500 feet to 300 feet?

If the uniform speed is 2 feet per second, at what rate is work being done in lifting (1) when the depth is 1500 feet, (2) when it is 300 feet?

2. How many foot-pounds of work are done in pumping 1 ton of water into a boiler against a pressure of 150 lbs. per square inch? If the pump has a solid ram of 2 inches diameter, with a 10-inch stroke, how many strokes are required and what is the thrust on the ram?

1 cubic foot of water weighs 62.5 lbs.

3. The values of the net pressure on the piston of an engine during one stroke are given in the following table. The length of the stroke is 16 inches, and the distances are measured in inches from one end of the stroke. The pressures are given in lbs. per square inch.

Distance	0	2	4	6	8	10	12	14	16
Pressure	40	72	75	50	32	26	22	18	10

Draw a graph connecting the pressure and the distance and find the space-average of the pressure.

If the piston diameter is 14 inches, how much work is done during the stroke?

4. What do you understand by the expressions "the work done by a force," and "the power supplied by an agent"? In what units are these quantities usually measured?

A truck, weighing 8 tons, is being drawn by a horse along a siding on a down grade of 1 in 400, the horse exerting a constant horizontal pull of 120 lbs. on a chain inclined at 30° to the rails. The frictional resistances to motion of the truck amount to 12 lbs. per ton. Find how far the truck will be moved from rest in one minute, and the power which the horse is exerting at the end of the minute.

5. The table below gives the horse-power transmitted by the propeller shafts for different speeds in the case of the "Mauretania" Atlantic Liner.

Draw a graph shewing how the resistance overcome varies with the speed.

Shaft horse-power	12,500	20,000	27,300	37,500	51,000	75,000
Speed in knots	16	18	20	22	24	26

6. A planing machine is working with its stroke set at 4 feet, and is planing a piece of work 3 feet long, the tool clearing the work 6 inches at each end. There is a constant frictional resistance equivalent to 45 pounds at the tool, and the cutting resistance is 560 lbs. more. The machine makes 20 complete strokes per minute. Find its average rate of working, in horse-power.

If the cutting stroke take twice as long as the return stroke, find the average speed of each, and if the highest cutting speed is $1\frac{1}{2}$ times the mean, find the greatest rate of working.

7. A wagon weighing 10 tons is running at 6 miles per hour when the brakes are applied and it is brought to rest in 15 yards. How much work is done in bringing the wagon to rest, and what is the space-average of the total braking force?

8. A car, for which the frictional resistance is 30 lbs. per ton, is travelling on the level at the rate of 30 feet per second, when it comes to a hill of 1 in 20, and after the speed has become steady on the hill the engine is working at the same power as on the level. Find this steady speed.

If while the car is slowing down the tractive force of the engine increases uniformly with the distance from the bottom of the hill until it reaches its steady value on the hill, find how far the car travels before reaching its steady speed.

9. The road and wind resistance to the motion of a motor-car weighing 30 cwt. is given by $(40 + 0.03 v^2)$ lbs., where v is the speed in miles per hour. What horse-power will be required to drive the car up a hill of 1 in 30 at a steady speed of 20 miles per hour?

If the maximum tractive force the motor can supply is 220 lbs., what is the maximum speed attainable up the hill?

10. A body is given kinetic energy by a force acting on it. How is the force related to the kinetic energy generated?

A railway wagon weighing 12 tons runs into a stop when travelling at 6 miles per hour. The buffer springs of the wagon are such that each exerts a force of 4 tons per inch of compression. Assuming the stop does not yield, find how much the springs are compressed when the wagon is for the instant brought to rest.

11. A motor-car, weighing 1 ton, ascends a hill of slope 1 in 12 at a uniform speed of 6 miles per hour. When it reaches the top it begins to travel down a uniform slope of 1 in 40. If the tractive force produced by the engine and the road-and-wind resistance are constant, find what the velocity and the kinetic energy will be when the car has travelled 25 yards down the slope.

12. A 5 ton truck is pulled from rest up a slope of 1 in 50; the pull to just move it on the level is 126 pounds; the tension in the rope varies with the distance (along the slope) as given below. Find the total work done, the kinetic energy at the end, and the horse-power exerted at the distance of 15 feet.

Distance in feet	0	5	10	15	20	25	30	35	40
Pull in lbs.	450	570	620	640	620	550	470	410	350

13. A body is acted upon by a force which causes motion. How are the momentum and the kinetic energy generated, each related to the force acting?

It is estimated that the actual work done in accelerating a steamer of 1000 tons displacement from rest, for the first 210 seconds, is 4500 foot-tons, and the distance travelled is 2000 feet. Find,

- (1) the speed attained,
- (2) the space-average of the accelerating force,
- (3) the time-average of the accelerating force.

14. The total pressure on the base of a shell during its passage along the bore is given in the table below. The total travel is $4\frac{1}{2}$ feet and it may be assumed that 6 per cent. of the pressure is used in overcoming friction and imparting rotation to the shell. Plot the pressure-distance curve and estimate the muzzle velocity of the shell, given that it weighs 12 lbs.

Distance in feet	0	$\frac{1}{4}$	$\frac{1}{2}$	$\frac{3}{4}$	1	$1\frac{1}{4}$	$1\frac{1}{2}$	$1\frac{3}{4}$	2	$2\frac{1}{2}$	3	$3\frac{1}{2}$	4	$4\frac{1}{2}$
Total pressure, tons	4	54	97	123	130	124	106	91	81	62	50	40	30	25

15. A train, running on the level, with steam shut off, has its speed reduced from 52 miles per hour to 48 miles per hour in 800 yards. Assuming that the resistance to motion is constant, find its value per ton of the train.

If the train weighs 200 tons, at what rate, in horse-power, must work be done to keep it moving at 50 miles per hour against the same constant resistance?

16. A motor lorry, of total weight 8 tons, starts from rest and is observed to have the accelerations at different points given below :

Distance, feet	0	10	20	30	40	50
Acceleration, ft. per sec. per sec.	2.1	1.57	1.2	0.87	0.54	0.30

Find the accelerating force for each distance, and plot a force-distance curve. From the curve, find the total work done in accelerating, and the velocity at each distance.

17. State the principle of conservation of energy as it applies to mechanical problems.

A mass is suspended by a string ABC , 3 feet long, from the point A , and is swinging through an angle of 30° on either side of the vertical. Find the velocity of the mass when it is vertically below A .

If at this instant the point B in the string is suddenly fixed, find the new angle of swing, AB being equal to $\frac{1}{2} BC$.

18. A light spring, whose inertia may be neglected, is such that a $\frac{1}{2}$ lb. weight will compress it 1 inch. It is compressed 2 inches and placed on a table so that it will expand in a vertical direction. If a $\frac{1}{4}$ lb. weight is put upon it and the spring is released, what is the velocity of the $\frac{1}{4}$ lb. at the instant that it leaves the spring?

19. In fig. 98 A is a hard steel shaft which can slide horizontally in the bearings BB . It is provided with stops which are just in contact with the end of the spring buffer. A lead bullet moving with a velocity of 1000 feet per second strikes the end of the shaft in the centre. The mass of the shaft is 5 lbs., that of the bullet 0.04 lb., and the spring compresses 1 inch under a load of 20 lbs. The force required to overcome the friction of the shaft is 1 lb. Assuming that the mass of the spring may be neglected, find to the nearest hundredth of an inch by how much the spring is compressed by the blow.

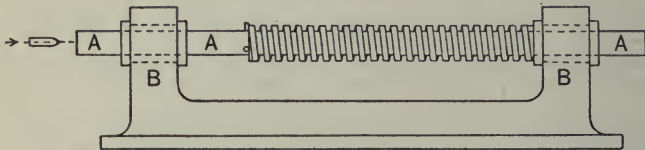

Fig. 98.

20. A bullet, weighing 0.025 lb. and moving with a velocity of 2000 feet per second, strikes a ballistic pendulum weighing 20 lbs., and remains in it after the impact. Determine the percentage of kinetic energy lost, and the average pressure exerted between the bullet and pendulum, supposing the former to come to rest after travelling six inches.

21. A railway wagon of total load 20 tons is shunted on to a siding and reaches a hydraulic buffer stop at a speed of 6 miles per hour. The buffer stop is such that it exerts a substantially steady force of 40 tons while the buffers are being pushed in, but only exerts a negligible force while returning. The wagon buffer springs each require a force of 4 tons to compress them 1 inch.

Find (1) the distance the wagon moves before coming to rest after striking the buffer stop, (2) the velocity of the wagon at the instant it leaves the buffer stop.

22. A steamer of 10,000 tons, when its engines are not working, slows down from 7 to 5 feet per second in 90 feet. Find the average resistance to motion.

If the engines are started and the speed is uniformly increased from 5 to 7 feet per second in 120 feet at what average rate in horse-power are the engines working during this motion, the resistance to motion being taken as uniform, and equal to the average resistance in the first part of the question?

23. A train weighing 200 tons has its speed reduced by a constant braking force from 60 miles per hour to 40 miles per hour in 4 seconds. Determine the change in the momentum of the train, the change in its kinetic energy, and the distance travelled. Also find the value of the retarding force, taking it as (1) the change of momentum per second, and (2) the change of kinetic energy per foot of distance.

24. The propulsion horse-power required to drive a steamer of 12,000 tons displacement at a steady speed of 20 knots is 15,000. Assuming that the resistance is proportional to the square of the speed, and that the engine exerts a constant propeller thrust at all speeds, find the initial acceleration, when the steamer starts from rest, and the acceleration when the speed is 10 knots.

(Take 1 knot=100 feet per minute.)

25. Shew that the twisting moment in a shaft which is transmitting power is given by $\frac{33000H}{2\pi N}$, where H is the horse-power transmitted and N the number of revolutions per minute.

A torsion dynamometer, which registers the angle of twist per foot length of the shaft when running, was used to determine the horse-power given out by a steam turbine. The mean speed of the shaft was found to be 2000 R.P.M. and the dynamometer registered 8.25 minutes. Find the horse-power given out by the turbine, having given that a couple of 72 inch-lbs. applied to the shaft produces an angle of twist per foot length of one minute.

26. The drum of a capstan has an effective diameter of 10 inches. Eight men on the capstan bars, walking round three times a minute, at a mean radius of $5\frac{1}{2}$ feet, can produce a pull of $2\frac{1}{2}$ tons in the rope being wound up. Find the horse-power got out, and the horse-power wasted in friction etc., assuming each man exerts a force of 70 lbs. on the bars. The tension in the rope coming off the drum may be neglected.

27. What is understood by the moment of inertia of a body about an axis?

Shew that the kinetic energy of a body rotating with angular velocity ω about an axis is $\frac{1}{2} I \omega^2$, where I is the moment of inertia of the body about the axis.

A rectangular door of sides 10 and 6 feet and weighing 500 lbs., swings about a horizontal axis fixed along its greater edge; find its angular velocity as it reaches the vertical from rest in the horizontal position. What is the pull on the axis as it reaches the vertical? What would be the angular velocity if the hinges exert a constant frictional couple of 100 inch-lbs.?

28. An engine works against a constant load which absorbs 25 horse-power when the speed is 250 revolutions per minute. The flywheel of the engine weighs 3 tons, and its radius of gyration is 3 feet.

Find (1) the work done against the load in one revolution, (2) the energy stored in the flywheel when the speed is 250 revolutions per minute.

If the source of power be cut off while the load remains constant, in how many revolutions will the speed drop from 250 to 240 revolutions per minute?

29. The figure below shews the torque exerted on the crank of a two-cylinder tandem gas engine for different crank angles during one revolution. The torque scale is such that 1 inch = 40,000 lbs. feet.

The moment of inertia of the flywheel is 90 tons ft.² units, and the speed is 200 revolutions per minute. The engine is working against a constant resisting moment, and giving the same torque-angle diagram every revolution.

Find graphically the resisting torque and estimate the maximum percentage fluctuation of flywheel speed.

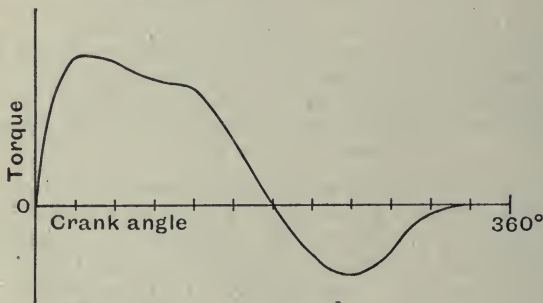

Fig. 99.

30. A 6-inch shaft is being turned in a lathe and it is found that the tangential pressure on the tool at the cutting edge is 785 lbs. The traverse of the saddle is $\frac{1}{8}$ inch per revolution of the mandrel and the speed of the latter is 20 revolutions per minute. Find the energy usefully expended in cutting per foot of traverse. Find also the efficiency of the machine if 1.3 horse-power is being supplied by the belt.

31. Two uniform discs of steel are each 3 feet in diameter. They are mounted side by side on the same shaft, and are free to move independently and without friction. One disc A is rotating at 500 revolutions per minute, the other, B, is at rest. A projection on the disc A impinges on a similar projection on the disc B and the blow dissipates one-fifth of the kinetic energy. Find the angular velocities of the two discs after the blow, and determine how long it will be until the projection on B overtakes the projection on A.

Also find the magnitude of the blow, if each disc weigh 250 lbs. and if the projections on the disc are each 15 inches from the centre of the shaft.

32. In example (14), p. 109, shew that the kinetic energy of the system is reduced in the ratio 4 to 5.

CHAPTER VII

Units and Dimensions

IN the first chapter we noted that there were three fundamental conceptions, space, mass, and time, and we saw how these were measured in certain units. The units were those of **length**, **mass**, and **time**.

We also called attention to the fact that all physical quantities could be defined in terms of these fundamental units. In the previous chapters we have introduced all the physical quantities we require in elementary dynamics, and we have based the measurement of each of these quantities directly on the fundamental units, or on physical quantities the measurement of which had already been based on these units.

It will be useful, as a revision of the previous chapters and also for other purposes, to examine again, in some detail, how each of the physical quantities we have introduced and used is related to the units of length, mass, and time. We shall then be able to see immediately how the measure of each quantity would be affected by a change in any or all of the fundamental units. We will denote these by L , M , and T respectively.

Let us consider *density*. This we defined as the mass per unit volume, i.e. the mass of a body divided by the volume of the body.

Now the volume is equal to the product of length, breadth and thickness, and each of these is a length. We say, therefore, that volume has three elements of length or, has the dimensions (length)³, i.e. L^3 .

$$\begin{aligned} \therefore \text{Density has the dimensions } & \frac{M}{L^3} \\ & = L^{-3} \cdot M \cdot T^0, \end{aligned}$$

T^0 denoting that it has no time dimension.

The significance of this will perhaps be realised better if we take a concrete example.

Example (1). *The density of steel in c.g.s. units is 7.78. Find the density in F.P.S. units, given that, 1 centimetre = 0.0328 foot, and 1 gram = 0.00221 lb.*

The dimensions are $L^{-3} \cdot M \cdot T^0$.

$$\begin{aligned} \therefore \text{The density in lbs. per cubic foot} \\ &= 7.78 \times (0.0328)^{-3} \times 0.00221 \\ &= 484. \end{aligned}$$

We will now find the dimensions of certain quantities in length, mass, and time.

Dimensions

Absolute System of Units

- Velocity (linear) = $\frac{\text{length}}{\text{time}} = L \cdot T^{-1} = L \cdot M^0 \cdot T^{-1}$.
- Acceleration (linear) = $\frac{\text{velocity}}{\text{time}} = L \cdot T^{-1} \cdot T^{-1} = L \cdot M^0 \cdot T^{-2}$.
- Angle (radians) = $\frac{\text{arc}}{\text{radius}} = L \cdot L^{-1} = L^0 \cdot M^0 \cdot T^0$.
- Angular velocity = $\frac{\text{radians}}{\text{time}} = T^{-1} = L^0 \cdot M^0 \cdot T^{-1}$.
- Angular acceleration = $\frac{\text{angular velocity}}{\text{time}} = T^{-1} \cdot T^{-1} = L^0 \cdot M^0 \cdot T^{-2}$.
- Momentum = mass \times velocity = $M \cdot L \cdot T^{-1} = L \cdot M \cdot T^{-1}$.
- Force = $\frac{\text{momentum}}{\text{time}} = M \cdot L \cdot T^{-1} \cdot T^{-1} = L \cdot M \cdot T^{-2}$.
- Weight = force = $L \cdot M \cdot T^{-2}$.
- Impulse = force \times time = $L \cdot M \cdot T^{-2} \cdot T = L \cdot M \cdot T^{-1}$.
- Angular momentum = momentum \times distance = $L \cdot M \cdot T^{-1} \cdot L$
 $= L^2 \cdot M \cdot T^{-1}$.

$$\text{Torque} = \text{force} \times \text{distance} = \text{L} \cdot \text{M} \cdot \text{T}^{-2} \cdot \text{L} = \text{L}^2 \cdot \text{M} \cdot \text{T}^{-2}.$$

$$\text{Impulsive torque} = \text{torque} \times \text{time} = \text{L}^2 \cdot \text{M} \cdot \text{T}^{-2} \cdot \text{T} = \text{L}^2 \cdot \text{M} \cdot \text{T}^{-1}.$$

$$\text{Moment of inertia} = \text{mass} \times (\text{distance})^2 = \text{M} \cdot \text{L}^2 = \text{L}^2 \cdot \text{M} \cdot \text{T}^0.$$

$$\text{Work} = \text{force} \times \text{distance} = \text{L} \cdot \text{M} \cdot \text{T}^{-2} \cdot \text{L} = \text{L}^2 \cdot \text{M} \cdot \text{T}^{-2}.$$

$$\text{Energy} = \text{capacity for work} = \text{L}^2 \cdot \text{M} \cdot \text{T}^{-2}.$$

$$\text{Power} = \frac{\text{work}}{\text{time}} = \text{L}^2 \cdot \text{M} \cdot \text{T}^{-2} \cdot \text{T}^{-1} = \text{L}^2 \cdot \text{M} \cdot \text{T}^{-3}.$$

Use of dimensions in checking formulae

If we have an equation involving physical quantities, the dimensions in each of the units, length, mass, and time, must be the same on the two sides of the equation. If this were not so, by changing the units of length, mass, and time we should alter the equation.

Suppose, for example, in an equation, the dimensions of the left-hand side in mass were M^2 , and on the right-hand side M , and we wished to change from lbs. to grams. We should multiply the left-hand side by $(453.6)^2$ and the right-hand side by 453.6, which would completely alter the equation.

We will examine a few of the formulae we have derived in the previous chapters. The student should examine all the remainder.

(1) Net work done = kinetic energy gained,

$$\text{or} \quad F \cdot s = \frac{1}{2} Mv^2.$$

The left-hand side has dimensions, $\text{L}^2 \cdot \text{M} \cdot \text{T}^{-2}$.

The right-hand side has dimensions, $\text{M} \cdot (\text{L} \cdot \text{T}^{-1})^2$
 $= \text{L}^2 \cdot \text{M} \cdot \text{T}^{-2}.$

(2) Acceleration = $v \cdot \frac{dv}{ds}$,

The left-hand side has dimensions, $\text{L} \cdot \text{T}^{-2}$.

The right-hand side has dimensions, $\frac{\text{L} \cdot \text{T}^{-1} \times \text{L} \cdot \text{T}^{-1}}{\text{L}}$
 $= \text{L} \cdot \text{T}^{-2}.$

3) Torque = moment of inertia \times angular acceleration,

$$\tau = I \cdot A.$$

The left-hand side has dimensions, $L^2 \cdot M \cdot T^{-2}$.

The right-hand side has dimensions, $L^2 \cdot M \cdot T^{-2}$.

Example (2). Find the number of watts in 1 horse-power, having given: 1 lb. = 453.6 grams, 1 ft. = 30.48 cms., and $g = 32.2$ feet per sec. per sec.

1 horse-power = 550 ft.-lbs. per sec.

$$= 550 \times 32.2 \text{ abs. F.P.S. units of power.}$$

The dimensions of power are $L^2 \cdot M \cdot T^{-3}$.

$$\therefore 1 \text{ horse-power} = 550 \times 32.2 \times 30.48^2 \times 453.6$$

$$= 746 \times 10^7 \text{ ergs per sec.}$$

$$= 746 \text{ watts.}$$

CHAPTER VIII

Simple Harmonic Motion

IN many cases of motion we have a body which moves backwards and forwards about a mean position, as, for example, the piston of a steam engine or the pendulum of a clock.

We will now investigate a particularly simple form of such a motion called Simple Harmonic Motion.

A body is said to move with a simple harmonic motion in a straight line when it has an acceleration directed towards some fixed point in its path, and proportional to the distance of the body from the fixed point.

Suppose, for example, that a body P moves in the straight line A'A with simple harmonic motion about a fixed point O.

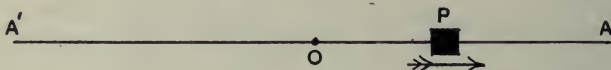

Fig. 100.

The acceleration will be in direction PO always, and equal to $\mu \cdot OP$, where μ is a constant*.

If we consider OA to be the positive direction of the displacement, the acceleration along PO will be negative, and we must write:—

$$\text{Acceleration} = -\mu \cdot s,$$

where $s = OP$.

* It should be noted that μ is a constant for a definite system of units, but its value will change if the unit of time be changed. Writing acceleration = $\mu \times$ distance, we see immediately, that in order that the dimensions of the two sides of the equation may be the same, μ must have dimensions

$$L^0 \cdot M^0 \cdot T^{-2}.$$

Now suppose the body is started with a given velocity, u say, when it is at O , then, since the acceleration is always towards O , it follows that the velocity will gradually be diminished to zero, and the body will for an instant be at rest at the point A , say. The body P will then start moving back to O with a velocity which will increase to u , but in the direction AO . Exactly the same type of motion will now occur to the left of O . We see then, that the body will continue to move backwards and forwards along the path AA' .

The velocity-time curve must be something like that shewn in fig. 101,

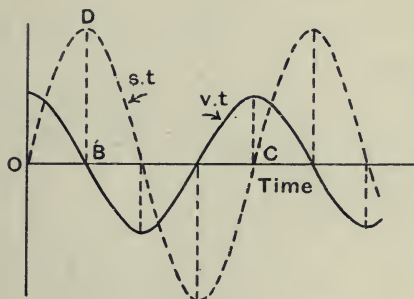

Fig. 101.

where OB represents the time to reach the first rest position A , and OC represents the time to make one complete reciprocation, i.e. the time for the body to travel from O to A , A to A' and A' to O . Also, we can see that the displacement-time curve must be something like the dotted curve in fig. 101, where BD represents OA .

Now in order to analyse the motion we want to know the exact shape of these curves.

For the space-time curve let us try the equation

$$s = a \sin bt.$$

From the example on p. 14 we have

$$\text{The velocity, } v = \frac{ds}{dt} = ab \cos bt.$$

$$\begin{aligned} \text{The acceleration, } a &= \frac{dv}{dt} = -ab^2 \sin bt \\ &= -b^2 \cdot s. \end{aligned}$$

If, therefore, we make b^2 equal to μ , we see immediately that this displacement is the one we want.

We have then for simple harmonic motion

$$\text{The acceleration} = -\mu \cdot s.$$

$$\text{The velocity} = a \cdot \sqrt{\mu} \cdot \cos \sqrt{\mu}t.$$

$$\text{The displacement} = a \sin \sqrt{\mu}t.$$

Also, we may obtain the acceleration in terms of the time, and the velocity in terms of the displacement.

$$\text{The acceleration} = -\mu a \sin \sqrt{\mu}t.$$

$$\begin{aligned} \text{The velocity} &= a\sqrt{\mu} \cdot \sqrt{1 - \sin^2 \sqrt{\mu}t} \\ &= a\sqrt{\mu} \cdot \sqrt{1 - \left(\frac{s}{a}\right)^2} \\ &= \sqrt{\mu} \cdot \sqrt{a^2 - s^2}. \end{aligned}$$

The periodic time is the time for one complete vibration.

This is the time for the body to move from O to A, A to A' and back to O.

From the curve we see that this is represented by the length OC, for which $\sqrt{\mu}t = 2\pi$,

$$\therefore \text{the periodic time} = \frac{2\pi}{\sqrt{\mu}}.$$

The greatest displacement (a) on either side of the centre is called the amplitude of the motion.

It should be noted that the *periodic time* is independent of the *amplitude* and depends only on the value of μ .

$$\text{But, } \mu = \frac{\text{Acceleration}}{\text{Displacement}}$$

Hence we may say, for any simple harmonic motion,

$$\text{The periodic time} = 2\pi \times \sqrt{\frac{\text{Displacement}}{\text{Acceleration}}}$$

Example (1). A mass of 4 lbs. is suspended from the end of a light helical spring, and when the system is at rest the spring is found to be extended 3 inches. The mass is now slowly depressed a further distance of 2 inches and then let go.

Find (a) the periodic time of vibration, (b) the maximum velocity.

Experiment shews that the pull produced by a helical spring is proportional to the extension.

If P = the pull, and x = the extension, then we may write

$$P = \lambda x, \text{ where } \lambda \text{ is a constant for the spring.}$$

In this case, when $P = 4g$ pdls.,

$$x = \frac{1}{4} \text{ feet.}$$

$$\therefore 4g = \frac{\lambda}{4},$$

or,

$$\lambda = 16g.$$

Let s = the displacement at any instant downwards from the equilibrium position.

From the 2nd law of momentum we have

$$(P - 4g) = 4a, \text{ where } a = \text{the acceleration upwards.}$$

$$\begin{aligned} \therefore a &= \frac{P - 4g}{4} \\ &= \frac{\lambda \left(\frac{1}{4} + s\right) - 4g}{4} \\ &= 4g \cdot s, \end{aligned}$$

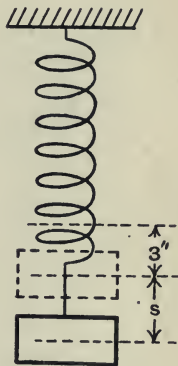

Fig. 102.

or, a varies as the displacement, and therefore the motion is simple harmonic.

$$\begin{aligned} \text{The periodic time} &= 2\pi \times \sqrt{\frac{\text{Displacement}}{\text{Acceleration}}} \\ &= 2\pi \sqrt{\frac{1}{4g}} \\ &= \frac{\pi}{4\sqrt{2}} \text{ seconds.} \end{aligned}$$

The number of complete vibrations per minute

$$\begin{aligned} &= \frac{4\sqrt{2}}{\pi} \times 60 \\ &= 108. \end{aligned}$$

The maximum velocity occurs when the mass passes the equilibrium position, i.e. when $s = 0$.

$$\begin{aligned} \therefore \text{The maximum velocity} &= \sqrt{\mu} \cdot a \\ &= \frac{1}{8} \sqrt{4g} \\ &= \frac{4\sqrt{2}}{3} \text{ feet per second.} \end{aligned}$$

Oscillation

Now suppose instead of a mass moving in a straight line we have a mass oscillating in a circle about a fixed axis. It is easily seen that all the reasoning we have just employed will hold, so long as we substitute angular displacement for linear displacement, angular velocity for linear velocity and angular acceleration for linear acceleration.

Simple Pendulum

A simple pendulum is a mass, which may be considered *small*, attached to a fixed point by a weightless rod or string and oscillating in a vertical plane.

Let m = the mass, l = the length of the string, and let the string make an angle θ with the vertical at some instant of time.

Treat the problem as one of rotation about O , and apply the 2nd law of momentum to the mass m .

The only forces acting on m are the tension T in the string and the weight mg .

The turning moment about O

$$= mgl \sin \theta.$$

The moment of inertia of m about $O = ml^2$, since the mass m is small.

$$\therefore mgl \sin \theta = -ml^2 \cdot A,$$

where A is the angular acceleration in a counter-clockwise direction.

$$\begin{aligned} \therefore \text{The angular acceleration} &= -\frac{mgl \sin \theta}{ml^2} \\ &= -\frac{g}{l} \cdot \sin \theta, \end{aligned}$$

i.e. the angular acceleration varies as $\sin \theta$.

This is not a case of simple harmonic motion, but if we keep the angle θ always small, i.e. the amplitude small, then $\sin \theta = \theta$, very nearly. In this case we may write,

$$\text{The angular acceleration} = \frac{g}{l} \cdot \theta,$$

i.e. the angular acceleration varies as the angle of displacement, and the motion is simple harmonic.

$$\begin{aligned} \text{The periodic time} &= 2\pi \times \sqrt{\frac{\text{Displacement}}{\text{Acceleration}}} \\ &= 2\pi \sqrt{\frac{l}{g}}. \end{aligned}$$

The fact, that for small swings the pendulum has a definite periodic time independent of the amplitude, is the reason why it is frequently employed to control clocks.

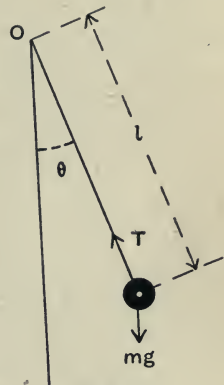

Fig. 103.

Example (2). Find the length of a simple pendulum to beat seconds, i.e. a pendulum which makes one complete oscillation in 2 seconds.

$$\text{The periodic time} = 2\pi \sqrt{\frac{l}{g}}$$

$$\therefore 2 = 2\pi \sqrt{\frac{l}{32}}$$

or,

$$l = \frac{32}{\pi^2} \\ = 3.25 \text{ feet.}$$

It may be noted that if we keep the length of the pendulum exactly constant, then for different positions on the earth's surface the periodic time will vary inversely as the square root of the acceleration due to gravity. This gives us a convenient means of comparing the values of g at different places.

Compound Pendulum

A body which is arranged to swing like a pendulum, but in which the whole mass is not concentrated at a point, is called a *compound pendulum*.

Let O be the centre of suspension, G be the centre of gravity, and let the body be at some instant in a position such that OG is inclined at an angle θ to the vertical. See fig. 104.

Let $OG = h$.

The weight may be considered to act through G .

The restoring moment about the axis

$$\begin{aligned} O &= mg \times OG \sin \theta \\ &= mgh \cdot \theta, \end{aligned}$$

if θ is always small.

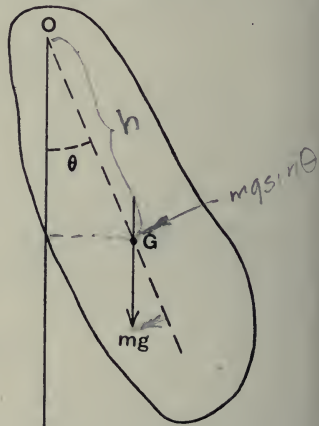

Fig. 104.

The equation of motion becomes

$$\mathbf{I} \cdot \mathbf{A} = -mgh \cdot \theta,$$

where \mathbf{I} is the moment of inertia of the body about \mathbf{O} , or,

$$\mathbf{A} = -\left(\frac{mgh}{\mathbf{I}}\right) \cdot \theta,$$

i.e. the body has a simple harmonic motion.

$$\text{The periodic time} = 2\pi \sqrt{\frac{\mathbf{I}}{mgh}}$$

$$= 2\pi \sqrt{\frac{k^2}{hg}},$$

where k is the radius of gyration of the body about \mathbf{O} .

For the simple pendulum, the periodic time

$$= 2\pi \sqrt{\frac{l}{g}}.$$

Hence the length of a simple pendulum which has the same periodic time as the compound pendulum

$$= \frac{k^2}{h}.$$

This length is called the length of the *simple equivalent pendulum* (S.E.P.).

Example (3). *The centre of gravity of a connecting rod is 4.5 feet from the centre of the small end. When suspended on a knife edge at the centre of the small end it has the same periodic time as a plumb-line of 6.2 feet. If the rod weighs 500 lbs., find the moment of inertia about an axis through the centre of gravity parallel to the axis of the end.*

We have the simple equivalent pendulum

$$= \frac{k^2}{h},$$

where k is the radius of gyration about the axis of the small end, and h is the distance 4.5 feet.

$$\therefore 6.2 = \frac{k^2}{4.5},$$

or,

$$k = \sqrt{6.2 \times 4.5} \\ = \sqrt{27.9}.$$

The moment of inertia about the axis through the centre of gravity

$$= Mk^2 - Mh^2 \\ = 500 \{27.9 - 4.5^2\} \\ = 500 \times (27.9 - 20.3) \\ = 3800 \text{ lbs. ft.}^2$$

Example (4). *A solid cylinder of radius r is free to oscillate in a vertical plane about a fixed axis A as shewn in the figure below. The cylinder is connected to the link AB by a pin joint at the axis, which is horizontal.*

Show that if the inertia and weight of the link AB is negligible

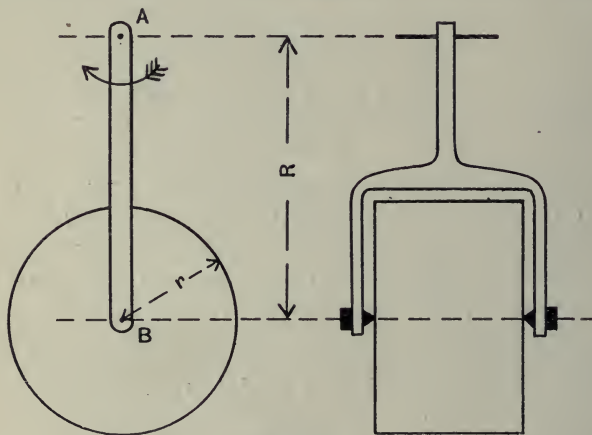

Fig. 105.

and there is no friction, the periodic time for a small oscillation will be given by $2\pi \sqrt{\frac{R}{g}}$.

Further shew that if the cylinder is fixed to the link the periodic time will be increased in the ratio $\sqrt{\frac{2R^2 + r^2}{2R^2}}$.

1st Case. Since the pin joint at B is frictionless, the only external forces acting on the cylinder are the pull P along link BA and the weight of the cylinder mg acting vertically downwards.

Now since there is no couple on the cylinder, it will have no rotation about B, and a diameter which is horizontal, say, will remain horizontal, i.e. there will be no relative motion between any point of the cylinder and B.

Therefore the acceleration of every point of the cylinder will equal the acceleration of B. The latter may be considered as consisting of two components,

(1) an acceleration $\omega^2 BA$ in the direction BA, where ω is the angular velocity of AB, and

(2) an acceleration a , say, perpendicular to BA.

Also, $a = R \cdot \Omega$, where Ω is the angular acceleration of BA.

Resolving the forces on the cylinder perpendicular to BA we get

$$mg \sin \theta = -mR \cdot \Omega,$$

i.e.
$$\Omega = -\frac{g}{R} \cdot \theta, \text{ if } \theta \text{ is small.}$$

This is a simple harmonic motion.

$$\text{The periodic time} = 2\pi \sqrt{\frac{R}{g}}.$$

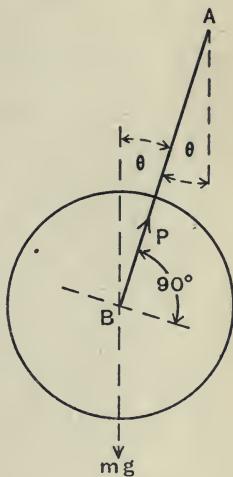

Fig. 106.

2nd Case. If the cylinder is fixed to the link it will rotate with the link and we get a compound pendulum as treated on p. 172.

The moment of inertia about A = $mR^2 + \frac{mr^2}{2}$.

∴ The (radius of gyration)² about A = $R^2 + \frac{r^2}{2}$.

The centre of gravity of the pendulum is at a distance R from A.

$$\therefore \text{The periodic time} = 2\pi \sqrt{\frac{R^2 + \frac{r^2}{2}}{Rg}},$$

i.e. the periodic time is increased in the ratio $\sqrt{\frac{2R^2 + r^2}{2R^2}}$.

It will be seen that in the first case the arrangement behaves as a simple pendulum of length R, and it will be remembered that in the simple pendulum the mass was to be considered small, i.e. we were neglecting the rotation of the mass itself about its centre of mass. This is equivalent, in the above example, to neglecting the term $\frac{mr^2}{2}$.

Example (5). *The balance wheel of a watch weighs $\frac{1}{300}$ ounce, and its radius of gyration is $\frac{1}{4}$ inch. It is controlled by a flat spiral spring and has a periodic time of $\frac{1}{2}$ second. What torque per degree of twist must the spring exert?*

Let λ = the torque in lbs. inch exerted by the spring per degree of twist.

If the wheel is rotated through θ radians from its mean position, then

The restoring couple due to the spring

$$= \frac{\lambda \cdot \theta \times 180 \times g}{\pi \times 12} \text{ pdls. ft.}$$

Let A = the angular acceleration of the wheel in the direction of twist.

The equation of motion of the wheel is,

$$\frac{1}{300 \times 16} \times \left(\frac{1}{48}\right)^2 \times A = - \frac{\lambda \cdot \theta \times 180 \times g}{\pi \times 12},$$

i.e.
$$A = - \frac{\lambda \times 15 \times 4800 \times 16 \times 144 \times 32}{\pi} \cdot \theta$$

$$= - (1.89 \times 10^9 \times \lambda) \cdot \theta.$$

The periodic time =
$$\frac{2\pi}{\sqrt{1.89 \times 10^9 \times \lambda}} = \frac{1}{2}.$$

$$\therefore \lambda = \frac{16\pi^2}{1.89 \times 10^9} = 8.96 \times 10^{-8} \text{ lbs. ins.}$$

Harmonic Motion and Circular Motion

We will now see how we can obtain mechanically a simple harmonic motion from a circular motion or vice-versa.

In fig. 107, Q represents a pin fixed to a circular disc which is rotating about O. This pin engages with a slotted link K constrained by guides to move in a line passing through O.

As the disc is rotated the pin Q will slide in the slot, and the link K will move backwards and forwards in a straight line. Draw QP perpendicular to the line of motion of K, then the motion of P will be the same as the motion of the link K.

Suppose the disc is rotated with a constant angular velocity ω .

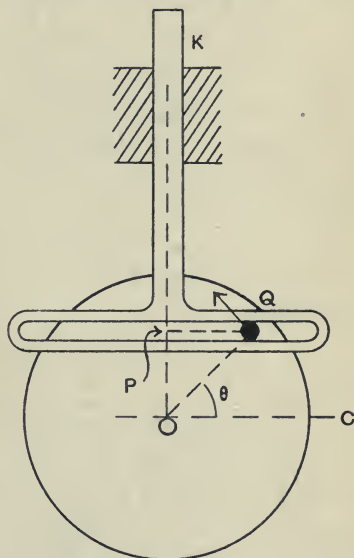

Fig. 107.

The acceleration of $Q = \omega^2 \cdot QO$, and is always towards O .

The acceleration of $P =$ the component of the acceleration of Q in the line PO ,

$$\begin{aligned} &= \omega^2 \cdot QO \cdot \cos \hat{P}OQ \\ &= \omega^2 \cdot PO, \end{aligned}$$

i.e. the acceleration of P is always towards O , and varies as its displacement from O .

$\therefore P$ has a simple harmonic motion.

It is easy to see that the periodic time is the time for Q to make one complete rotation, i.e. $\frac{2\pi}{\omega}$. Here ω^2 corresponds to μ in the previous pages.

The other results follow very simply.

The velocity of $P =$ the component of Q 's velocity in the direction OP ,

$$\begin{aligned} &= \omega \cdot OQ \cdot \sin \hat{P}OQ \\ &= \omega \cdot OQ \cdot \cos \hat{Q}OC, \end{aligned}$$

where OC is perpendicular to OP (fig. 107).

If $OQ = a$, and if we start measuring the time when P is at O ,

the angle $QOC = \omega t$.

\therefore The velocity of $P = \omega a \cos \omega t$.

For the displacement, in the same way, we have

$$\begin{aligned} s &= OP \\ &= a \sin \omega t. \end{aligned}$$

Crank and connecting rod

In the crank and connecting rod mechanism, used in steam engines and other machines, the slotted link is replaced by a connecting rod QA , as shewn in fig. 108. The crosshead has not a true simple harmonic motion.

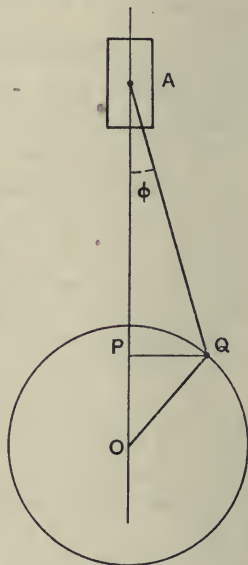

Fig. 108.

We can see, however, that if the rod QA is very long compared with the crank OQ , then the angle ϕ will always be small and the motion of A will be very nearly the same as that of P , where QP is perpendicular to the line of stroke,

i.e. A has approximately a simple harmonic motion.

Example (6). *The slide-valve of a steam engine has a total travel of 4 inches. It is driven from the crank shaft by an eccentric, the rod of which is so long compared with the travel that the motion of the valve may be considered simple harmonic. If the crank shaft rotates at 240 revolutions per minute, find (1) the maximum velocity of the valve, (2) the velocity of the valve at one-third of the stroke, (3) the time to travel the middle third of its path.*

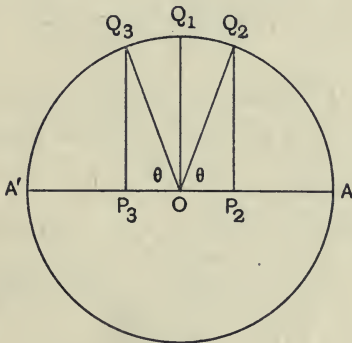

Fig. 109.

Let AA' represent the travel of the valve, i.e. 4 inches. Draw a circle with AA' as diameter. The motion of the valve will be given by the component of motion, parallel to AA' , of a point Q rotating round the circle with an angular velocity (ω) equal to that of the crank shaft.

$$\begin{aligned} \therefore \omega &= \frac{2\pi \times 240}{60} \\ &= 8\pi \text{ radians per second.} \end{aligned}$$

(1) The maximum velocity will occur when the valve is at O, i.e. Q is at Q₁.

$$\begin{aligned}\therefore \text{The maximum velocity} &= 8\pi \times \frac{2}{1\frac{1}{2}} \\ &= 4.19 \text{ feet per second.}\end{aligned}$$

(2) Let OP₂ = $\frac{1}{6}$ AA'.

The velocity at one-third stroke

$$\begin{aligned}&= 4.19 \sin \theta \\ &= 4.19 \times \frac{P_2Q_2}{OQ_2} \\ &= \frac{4.19 \times \sqrt{2^2 - (\frac{2}{3})^2}}{2} \\ &= 3.94 \text{ feet per second.}\end{aligned}$$

(3) Let OP₃ = $\frac{1}{6}$ AA'.

The time to travel the middle third of the stroke, i.e. P₂P₃,
= the time for Q to rotate through an angle ($\pi - 2\theta$)

$$= \frac{\pi - 2\theta}{8\pi} \text{ seconds.}$$

Now $\cos \theta = \frac{1}{3}$,

i.e.

$$\theta = 70.5^\circ = 0.391 \pi \text{ radians.}$$

$$\begin{aligned}\therefore \text{The time required} &= \frac{1 - 0.782}{8} \\ &= 0.0272 \text{ second.}\end{aligned}$$

Example (7). *The drum of a steam engine indicator is driven by a cord wrapped round part of the drum and is controlled by a helical spring which always exerts a couple opposed to that produced by the pull of the cord. The end of the cord has a motion proportional to the piston's motion, and the latter may be assumed to be simple harmonic. Shew that, neglecting friction and the effect of stretch of the cord, the spring must be wound up so that the mean*

torque it exerts on the drum is not less than the absolute magnitude of $\lambda a \left\{ \frac{N^2}{n^2} - 1 \right\}$, where N = the speed of the engine in revolutions per minute, n = the number of oscillations the drum would make per minute if oscillating freely under the control of the spring, λ = the torque required to twist the spring through 1 radian, and a = the amplitude of the motion of the drum.

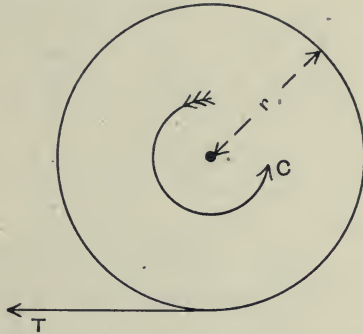

Fig. 110.

Let θ = the angle of rotation of the drum measured in a clockwise direction from the mean position.

Let C = the couple produced by the spring for this position.

„ T = the tension in the cord.

„ r = the radius of the drum.

„ I = the moment of inertia of the drum.

The resultant torque on the drum = $Tr - C$.

∴ From the 2nd law of momentum we have

$$Tr - C = I \cdot A \dots\dots\dots(1),$$

where A is the angular acceleration measured in a clockwise direction.

Let ϕ = the angle of twist of the spring when the drum is in its mean position.

For angle of rotation θ , the angle of twist in the spring = $(\phi + \theta)$.

$$\therefore C = \lambda (\phi + \theta).$$

Substituting in (1) we get

$$T.r - \lambda (\phi + \theta) = I.A \dots\dots\dots(2).$$

The motion of the end of the string is given by

$$x = ra \sin \omega t, \text{ where } \omega = \frac{2\pi N}{60}.$$

But

$$x = r\theta,$$

$$\therefore \theta = a \sin \omega t.$$

Also

$$A = -a\omega^2 \sin \omega t.$$

\therefore From (2) we get

$$Tr = \lambda (\phi + a \sin \omega t) - I a \omega^2 \sin \omega t,$$

i.e.

$$Tr = \lambda \phi - (I a \omega^2 - \lambda a) \sin \omega t.$$

Now if the drum's motion is to be the same as that of the string T must always be positive, and if $(I a \omega^2 - \lambda a)$ is positive, $\lambda \phi$ must be not less than $(I a \omega^2 - \lambda a) \sin \omega t$.

The maximum value of $\sin \omega t = 1$.

$$\therefore \lambda \phi \leq I a \omega^2 - \lambda a.$$

But $\lambda \phi$ = the mean torque due to the spring.

$$\therefore \text{The mean torque} \leq \lambda a \left\{ \frac{I \omega^2}{\lambda} - 1 \right\} \dots\dots\dots(3).$$

Suppose the drum were oscillating with its own spring, and there were no cord, we should have

$$-\lambda \theta = I.A,$$

i.e.

$$A = -\frac{\lambda}{I} \cdot \theta,$$

which is a simple harmonic motion.

The periodic time $= 2\pi \sqrt{\frac{\bar{I}}{\lambda}}$.

But the periodic time $= \frac{60}{n}$.

$$\therefore \frac{\bar{I}}{\lambda} = \frac{60^2}{4\pi^2 n^2}.$$

Also $\omega^2 = \frac{4\pi^2 N^2}{60^2}$.

\therefore From (3),

$$\text{the mean torque} \prec \lambda \alpha \left\{ \frac{N^2}{n^2} - 1 \right\}.$$

If $(I\alpha\omega^2 - \lambda\alpha)$ is negative, i.e. $\left(\frac{N^2}{n^2} - 1\right)$ is negative, then we must take $\sin \omega t = -1$, and we get

$$\text{the mean torque} \prec \lambda \alpha \left\{ 1 - \frac{N^2}{n^2} \right\},$$

i.e. the mean torque must not be less than the absolute magnitude of $\lambda \alpha \left\{ \frac{N^2}{n^2} - 1 \right\}$.

Examples, Chapter VIII

1. A mass is suspended at the end of a light vertical spring, and when at rest stretches the spring l feet. Shew that if it is slightly displaced from this position of rest and then let go it will vibrate with a periodic time equal to $2\pi \sqrt{\frac{l}{g}}$, where g is the acceleration due to gravity in feet per second per second.

2. A body of mass 2 lbs. moves in such a way that the curve connecting its displacement (in feet) from a given point in its line of action and the time (in seconds) is represented by the equation $s = 2 \sin 3t$. Find the time of a complete oscillation, and the force acting on it when at a distance of 1 foot from the fixed point. Plot the velocity-time curve for a complete oscillation.

3. A pendulum of a clock beats seconds. If the clock keeps correct time in one place, how many seconds per day will it lose in a place where the acceleration due to gravity is decreased by $\frac{1}{100}$ per cent.?

4. A part of a machine weighing 60 lbs. describes Simple Harmonic Motion, making 180 complete vibrations per minute, and the length of the stroke is 2 feet. Find the greatest velocity, and the force acting on the moving part at one end of its stroke and at $\frac{1}{4}$ of its stroke.

5. A uniform rod, weighted at one end, floats in water with its axis vertical and part of the rod projecting above the free surface. The total weight of the rod is 3 lbs. and its cross-section is circular and of diameter 2 inches. If it is depressed vertically and then let go find the periodic time of vibration.

When a body is in water the upthrust on it is equal to the weight of the volume of water displaced.

6. A particle of mass m moves in a straight line under the action of a force, towards a point O in the line, the value of which, at a distance x from the point, is $m\mu x$. Determine the time of an oscillation.

Shew that the potential energy when the particle is at a distance x from O is $\frac{1}{2}m\mu x^2$.

Shew also that the motion of a simple pendulum making small oscillations approximates to the same type.

7. A simple pendulum, of length 3 feet, oscillates through an angle of 12 degrees on either side of the vertical. Using the principle of conservation of energy, find the maximum velocity. Compare this with the maximum velocity obtained by considering the motion to be simple harmonic.

8. A thin rod, 3 feet long, is pivoted at one end and oscillates through a small angle in a vertical plane. Find the periodic time of oscillation, and shew that it will be the same if the rod is pivoted at a point one-third the length from the end as it is when pivoted about the end.

9. A mass of 5 lbs. has a simple harmonic motion, the period of which is $\frac{1}{2}$ second and the amplitude 6 inches. Draw diagrams to stated scales shewing (i) the force acting on the mass as a function of the time, (ii) the velocity as a function of the displacement.

10. A flywheel is hung up with its axis vertical by two long ropes parallel to and equidistant from its axis so that it can execute torsional oscillations. It is found that a static couple of 50 lbs. ft. will turn it through an angle of one-tenth of a radian, and that if it be turned through a small angle and then let go the period of a complete oscillation backwards and forwards is 5 seconds. Calculate how much energy will be stored in this flywheel when running 200 revolutions per minute.

11. A mass of 5 lbs. is suspended by a spring, and when at rest, just touches the platform of a spring balance without the latter taking any of the weight. The spring is such that it extends 1 inch for 10 lbs. and the platform of the spring balance is depressed 1 inch for 20 lbs. If the mass of 5 lbs. is slowly depressed $\frac{3}{4}$ inch and then let go, find the periodic time of vibration. Find, also, the maximum height the mass rises and the maximum velocity it attains.

12. A Tee square, of the dimensions shewn in the figure, is suspended at A, and oscillates through a small angle in its own plane. The horizontal cross-piece is twice as thick as the vertical piece. Find the periodic time of oscillation.

13. A rectangular bar magnet, weighing 0.2 lb., is 6 inches long and of cross-section $\frac{1}{2}$ inch by $\frac{1}{2}$ inch. It is pivoted in a horizontal plane so that it is free to swing about a vertical axis through its middle. Find the periodic time of oscillation in a place where the earth's magnetic field has a horizontal intensity of 0.19 dyne, if the magnetic moment of the magnet is 400 dyne-cm. units.

14. A rotary valve for an engine makes 500 complete oscillations per minute about a horizontal axis, the total angle of rotation being 90 degrees. The motion is obtained from a rack which moves with a simple harmonic motion, and drives a pinion of effective diameter $1\frac{1}{2}$ inches keyed to the valve spindle. If the moment of inertia of the valve, spindle, and pinion is 30 lb.-inch units, find, neglecting friction, the maximum total pressure between the teeth of the rack and the pinion.

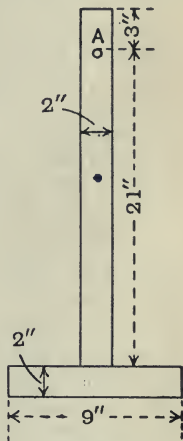

Fig. 111.

15. A machine is carried by, and in the middle of, two girders, built in at the ends. The dead weight of the machine causes a deflection of $\frac{1}{2}$ inch. Shew that if the girders weigh $\frac{1}{10}$ th of that of the engine, the frequency of a small vertical oscillation will be between 252 and 265 vibrations per minute.

Assume firstly, that all the weight of the girders is at the centre, and secondly, that the weight of the girders may be neglected in comparison with the weight of the machine.

16. The stroke of an engine is 6 inches, the connecting rod 10 inches, and the speed of the crank 720 revolutions per minute. The line of stroke passes through the axis of the crank shaft.

Draw the velocity-space curve for the motion of the piston, and from this construct the acceleration-space curve.

On the same diagram shew the acceleration-space curve, assuming the connecting rod infinitely long.

17. A uniform rectangular block of length 12 inches and of height 6 inches is suspended in a horizontal position by two vertical strings AB and CD , as shewn in the figure. The centre of gravity of the block is 2 feet below the points of suspension. Find the time of a small oscillation in the plane of the strings.

If the vertical strings are replaced by two equal strings OB and OD , the centre of gravity remaining at the same distance below the point of suspension, what will be the periodic time for small oscillations?

18. Shew that the motion of the crosshead of an engine is approximately simple harmonic.

Find the force that is necessary to start the reciprocating parts of an engine into motion at the beginning of each stroke, when the engine is running at 120 revolutions per minute. The mass of the reciprocating parts is 1 ton, the stroke is 5 feet and the obliquity of the connecting rod may be neglected.

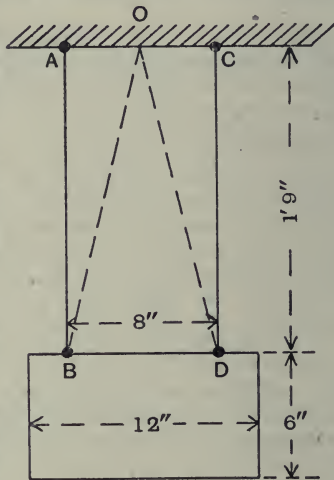

Fig. 112.

CHAPTER IX

MISCELLANEOUS

Transmission of power by belts

POWER is frequently transmitted from an engine shaft or motor shaft to a machine by means of a belt connecting pulleys on the two shafts as shewn in fig. 113. When the machine is doing work the tension in the two sides of the belt will be different.

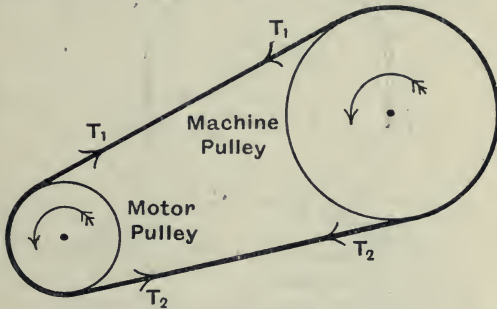

Fig. 113.

Let T_1 = the tension in lbs. wt. in the tight side of the belt,

T_2 = the tension in the slack side of the belt,

N = the speed in revolutions per minute of the machine shaft,

R = the radius of the pulley on the machine shaft in feet.

The resultant turning moment on the machine shaft

$$\begin{aligned} &= T_1R - T_2R \\ &= (T_1 - T_2)R \text{ lbs. ft.} \end{aligned}$$

The angle turned through in 1 minute = $2\pi N$ radians.

The work done per minute = $(T_1 - T_2)R \times 2\pi N$ ft.-lbs.

$$\therefore \text{The horse-power transmitted to the machine} = \frac{(T_1 - T_2) 2\pi NR}{33,000}.$$

Example (1). *In order to measure the horse-power which can be given out by an engine, a brake is arranged, consisting of a belt on the flywheel of 5 feet diameter, as shewn in fig. 114. A weight of 50 lbs. is attached to one side of the belt and a weight of 20 lbs. to the other side. The 20 lbs. weight is partly supported on a spring balance. When the flywheel is running at 150 revolutions per minute the spring balance reads 9.2 lbs. Find the horse-power absorbed by the brake.*

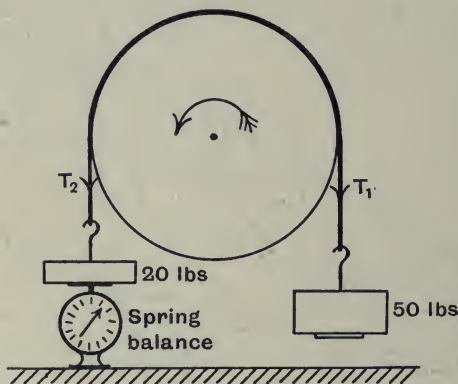

Fig. 114.

We have $T_1 = 50$ lbs. wt.,

and $T_2 = (20 - 9.2) = 10.8$ lbs. wt.

The resisting moment on the wheel

$$= (50 - 10.8) \times 2.5 \text{ lbs. ft.}$$

$$\therefore \text{The horse-power} = \frac{(50 - 10.8) \times 2.5 \times 2\pi \times 150}{33,000}$$

$$= \frac{39.2 \times 2.5 \times 6.28 \times 150}{33,000}$$

$$= 2.8.$$

Machines

A machine is an instrument for converting energy into useful work. In order to take in the energy supplied the *receiving end* of the machine will require a definite motion, depending on the form in which the energy is supplied. Also, the motion of the *working end* will have to be of a definite kind, depending on the nature of the work which is required to be done.

Take the case of a steam engine. Here the energy is supplied in the form of the pressure of the steam. This acts on a piston, and does work by moving it along a straight path. The receiving end has therefore a reciprocating motion. The working end, on the other hand, is required to rotate, and the force of the steam on the piston has to produce a couple causing rotation of the crank shaft against the resisting torque.

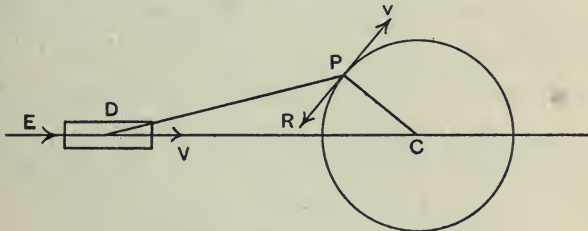

Fig. 115.

If we like, we can consider the torque on the crank shaft produced by a force R acting on the crank pin at right angles to the crank. In this case the crank pin becomes the working end and the piston becomes the receiving end.

Let v = the velocity of the piston or the crosshead
and $v =$ „ „ crank pin.

The *velocity ratio* of the machine

$$\begin{aligned}
 &= \frac{\text{The velocity of the receiving end}}{\text{The velocity of the working end}} \\
 &= \frac{v}{V}.
 \end{aligned}$$

If we may neglect friction and also the change in kinetic and potential energy of the moving points, then we must have for a *definite interval of time*,

The work put in at the receiving end
= the work got out at the working end.

Taking a unit interval of time we have,
The power supplied at the receiving end
= the power given out at the working end.

If E = the force exerted at the receiving end
and R = „ overcome at the working end,

$$E \cdot V = R \cdot v$$

or
$$\frac{R}{E} = \frac{V}{v},$$

i.e. the *force ratio* is inversely proportional to the *velocity ratio*.

Example (2). On p. 50 we found, for the position of the crank shown, the value of $\frac{V}{v} = \frac{42}{65}$. Suppose the steam pressure = 80 lbs. per sq. inch, and the diameter of the piston = 10 inches. Find the crank effort, i.e. the tangential force on the crank pin.

$$\begin{aligned} \text{The total pressure (E)} &= 25\pi \times 80 \\ &= 6280 \text{ lbs. wt.} \end{aligned}$$

$$\begin{aligned} \text{The crank effort (R)} &= \frac{V}{v} \times E \\ &= \frac{42}{65} \times 6280 \\ &= 4050 \text{ lbs. wt.} \end{aligned}$$

Friction. If we consider friction then there will be some energy wasted in heat, and the ratio of $\frac{R}{E}$ will no longer be equal to $\frac{V}{v}$.

The ratio $\frac{R}{E} = \frac{\text{Resistance}}{\text{Effort}}$ is called the *mechanical advantage* of a machine.

$$\begin{aligned} \text{The mechanical efficiency of a machine} &= \frac{\text{Power given out}}{\text{Power given in}} \\ &= \frac{Rv}{EV} \\ &= \frac{\text{Mechanical advantage}}{\text{Velocity ratio}}. \end{aligned}$$

Example (3). *Fig. 116 (a) on p. 192 shews diagrammatically the mechanism of a drawing press. ABC is a bell-crank lever pivoted at B. The end C is connected by the link CD to the piece D, which is constrained to move in direction BD. By drawing velocity triangles, find the ratio of the velocity of A to the velocity of D.*

Neglecting friction, what vertical force P applied at A is required to produce a vertical push of 1 ton on D?

The bell-crank lever ABC is pivoted at B, and therefore the velocity of A : the velocity of C as AB : BC.

In fig. 116 (b), draw *oa* perpendicular to AB, and equal to AB, to represent the velocity of A. Draw *oc* perpendicular to BC, and equal to BC, to represent the velocity of C.

The relative velocity of D to C must be perpendicular to CD, and the velocity of D is along BD.

Draw *cd* perpendicular to CD, and draw *od* parallel to BD.

The velocity of D equals the vector sum of the velocity of C and the relative velocity of D to C.

ocd is a triangle of velocities.

∴ *od* represents the velocity of D, to the same scale as *oa* represents the velocity of A.

$$\begin{aligned} \therefore \frac{\text{Velocity of A}}{\text{Velocity of D}} &= \frac{oa}{od} \\ &= \frac{1}{0.83} \text{ (by measurement)} \\ &= 1.2. \end{aligned}$$

Now P acts vertically. Draw *op* vertical, and draw *ap* perpendicular to *op*.

Then op represents the component of A's velocity in the direction of the force P .

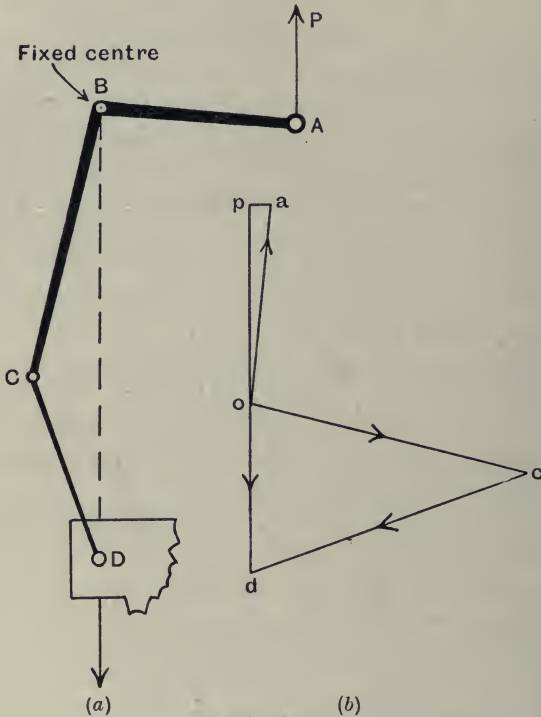

Fig. 116.

Employing the principle, work put in = work got out, we have

$$P \times op = F \times od,$$

where F is the force required at D.

$$\begin{aligned} \therefore F &= P \times \frac{op}{od} \\ &= 1 \times \frac{0.98}{0.83} \\ &= 1.18 \text{ tons.} \end{aligned}$$

Example (4). *The mechanical efficiency of a certain type of tackle may be taken equal to $\left(\frac{7}{7+n}\right)$, where n = the total number of sheaves round which the rope is wrapped.*

A runner tackle, in which the moving block has 3 sheaves and the fixed block 2 sheaves, is to be used to overcome a resistance of 5 tons.

What will be the pull in the running end of the rope, and the mechanical advantage of the tackle ?

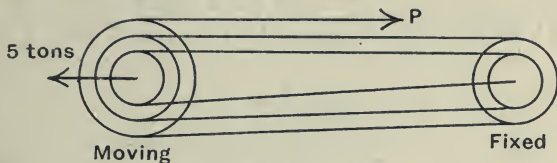

Fig. 117.

The sheaves are really all the same size and not as shewn in fig. 117, and the portions of the rope may be assumed parallel.

From the figure, we see that if the moving block shifts 1 foot there will be a motion of the running end equal to 6 feet.

∴ The velocity ratio = 6.

Let P = the pull of the running end, in tons wt.

$$\begin{aligned} \text{The mechanical efficiency} &= \frac{\text{Work done}}{\text{Work put in}} \\ &= \frac{5}{P \times 6}. \end{aligned}$$

$$\therefore \frac{5}{P \times 6} = \frac{7}{7+5},$$

or

$$\begin{aligned} P &= \frac{60}{42} \\ &= 1\frac{0}{7} \text{ tons wt.} \end{aligned}$$

The mechanical advantage

$$\begin{aligned} &= \frac{5}{P} \\ &= \frac{35}{10} \\ &= 3.5. \end{aligned}$$

Example (5). *In a steam tractor the motion is transmitted from the crank shaft A through two parallel shafts B and C. A wheel of 22 teeth on A gears with a wheel of 21 teeth on B. Compound with this wheel is a wheel of 17 teeth gearing with a wheel of 44 teeth keyed on shaft C. Keyed also on C is a wheel of 12 teeth gearing with a wheel of 56 teeth fixed to the road wheel.*

Find the velocity ratio of the gear, and, neglecting friction, find the couple required on the crank shaft to produce a total tractive force of 1000 lbs., the diameter of the road wheels being 7 feet.

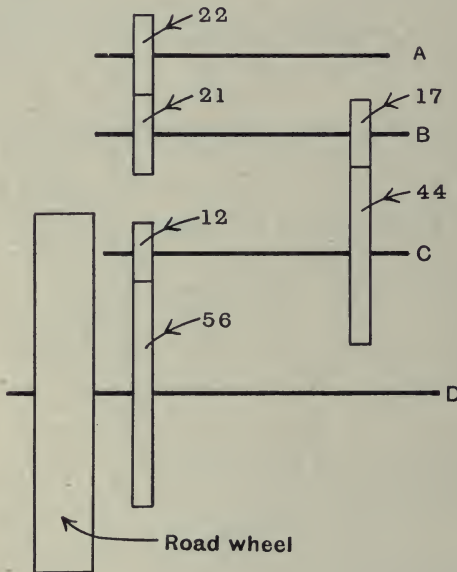

Fig. 118.

The arrangement of the gear is shewn diagrammatically in fig. 118.

For one revolution of the crank shaft A we have

Shaft B makes $\frac{2}{21}$ revolutions,

„ C „ $\frac{2}{21} \times \frac{17}{44}$ revolutions,

„ D „ $\frac{2}{21} \times \frac{17}{44} \times \frac{12}{56}$ revolutions.

$$\begin{aligned} \therefore \text{The velocity ratio of the gear} &= \frac{\text{Speed of A}}{\text{Speed of D}} \\ &= \frac{21 \times 44 \times 56}{22 \times 17 \times 12} \\ &= 11.53. \end{aligned}$$

Let T = the couple on the crank shaft in lbs. ft.

P = the tractive force in lbs., at the points of contact of the two road wheels.

The couple on the road wheels shaft D

$$= P \times \frac{7}{2} \text{ lbs. ft.}$$

Neglecting friction, we must have the work put into the crank shaft in any time = the work given out by the road wheels in the same time.

$$\therefore P \times \frac{7}{2} = T \times 11.53.$$

Putting $P = 1000$ lbs.,

we get
$$T = \frac{1000 \times 3.5}{11.53} = 303 \text{ lbs. ft.}$$

Relative Momentum and Relative Kinetic Energy

In dealing with motion we pointed out that we really do not know anything about absolute motion, and that all the motions we deal with are relative motions. In the same way, when we talk or write about momentum, and kinetic energy, since these involve velocity and speed, we are really implying relative momentum, and relative kinetic energy.

Momentum. Suppose we are determining the force acting on a body by considering the time-rate of change of momentum. If the momentum is changing uniformly with the time, we have

$$F = \frac{m(v - u)}{t},$$

where v and u are the final and initial velocities of the mass m , measured relatively to some body of reference.

Suppose the body of reference has itself a constant velocity V in the same direction as u and v , then the real change of momentum

$$\begin{aligned} &= m(v + V) - m(u + V) \\ &= m(v - u). \end{aligned}$$

Now we may assume that the *time* is the same whatever is our body of reference,

$$\therefore F = \frac{m(v - u)}{t}, \text{ as before.}$$

Kinetic Energy. Suppose we are determining the force acting on a body by considering the space-rate of change of kinetic energy. Again taking the force constant, relative to our body of reference, we have

$$F = \frac{m(v^2 - u^2)}{2s},$$

where s is the distance moved relative to the body of reference.

If the body of reference has a constant velocity V , then the real change of kinetic energy

$$\begin{aligned} &= \frac{m(v + V)^2}{2} - \frac{m(u + V)^2}{2} \\ &= \frac{m(v^2 - u^2)}{2} + mV(v - u). \end{aligned}$$

Let s' = the total distance moved during this change.

$$\text{Then} \quad Fs' = \frac{m(v^2 - u^2)}{2} + m(v - u)V.$$

$$\text{Now} \quad s' = s + Vt, \text{ and } F = \frac{m(v - u)}{t}.$$

$$\therefore Fs + F \cdot Vt = \frac{m(v^2 - u^2)}{2} + Ft \cdot V,$$

$$\text{i.e.} \quad F = \frac{m(v^2 - u^2)}{2s}, \text{ as before.}$$

Hence we may use *relative* kinetic energy if at the same time we use the *relative* displacement.

As an example, consider the energy required to accelerate or retard the piston of a locomotive which is travelling at any given speed relative to the earth. In estimating this, we are not concerned with the speed of the locomotive, but merely with the speed of the piston relative to the cylinder, and the distance moved by the piston relative to the cylinder while this change of speed has occurred.

In the same way, in order to find the total work done by the steam, we use the force-space curve, the force being the total pressure of the steam on the piston and the space being the relative displacement of the piston in its cylinder.

Indicated Horse-Power

The *indicated horse-power* (I.H.P.) of an engine is the horse-power supplied to the engine by the working substance, e.g. in a steam engine, the horse-power supplied by the steam as it acts on the piston. The term indicated is used since the I.H.P. is usually obtained by means of an *Indicator*. This is a small instrument which autographically records the force-space curve at the receiving end of the engine. An indicator diagram for a

steam engine in which the steam acts only on one side of the piston is shewn in fig. 119.

abc represents the pressure of the steam as the piston is moving in towards the crank shaft, i.e. during the forward stroke, and cda represents the pressure during the return stroke.

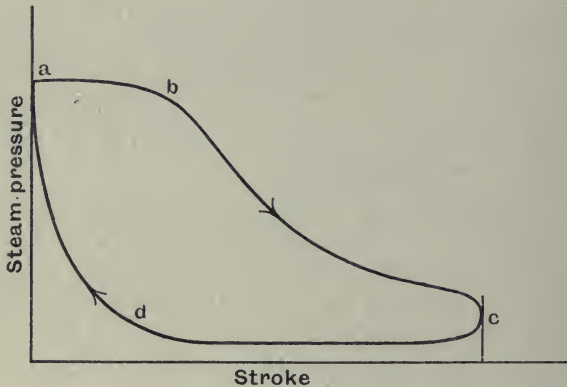

Fig. 119.

Let P_f = the mean pressure in lbs. per sq. inch during the forward stroke.

P_b = the mean pressure in lbs. per sq. inch during the return stroke.

A = the area of the piston in sq. inches.

L = the length of the stroke in feet.

N = the speed of the engine in revolutions per minute.

The work done by the steam during the forward stroke

$$= P_f \cdot A \cdot L \text{ ft.-lbs.}$$

The work done by the steam during the return stroke

$$= -P_b \cdot A \cdot L \text{ ft.-lbs.}$$

The negative sign is used since the engine has to do work in pushing the steam out of the cylinder.

∴ The work done by the steam per revolution

$$\begin{aligned} &= (P_f - P_b) \cdot AL \\ &= P \cdot A \cdot L \text{ ft.-lbs.,} \end{aligned}$$

where P is the mean effective pressure given by the diagram *abcd*.

This is obtained from the mean distance between the curves *abc* and *cda*, or the area *abcd* divided by the length of the diagram.

The work done per minute = $P \cdot A \cdot L \cdot N$ ft.-lbs.

$$\therefore \text{The indicated horse-power} = \frac{P \cdot L \cdot A \cdot N}{33,000}.$$

The *brake horse-power* (B.H.P.) or the horse-power which is given out by the engine may be obtained by using a brake such as is shewn in fig. 114, p. 188.

The difference between the indicated horse-power and the brake horse-power represents the horse-power which is wasted in friction in the engine itself.

The *mechanical efficiency*

$$= \frac{\text{Brake horse-power}}{\text{Indicated horse-power}}.$$

Example (6). *The driving wheels of a two-cylinder locomotive are 6 feet in diameter. The mean pressure of the steam in each cylinder is 60 lbs. per sq. inch. The diameter of the cylinders is 20 inches, and the stroke 22 inches. Find the indicated horse-power if the speed of the locomotive is 20 miles per hour.*

Find also the draw-bar pull produced, if 12.5 per cent. of the power supplied is wasted in friction.

The speed of the driving wheels and crank shaft

$$\begin{aligned} &= \frac{20 \times 5280}{60 \times \pi \times 6} \\ &= 93.5 \text{ revolutions per minute.} \end{aligned}$$

I.H.P. for one end of one cylinder

$$= \frac{60 \times \pi \times 10^2 \times 22 \times 93.5}{33,000 \times 12}$$

$$= 98.$$

$$\therefore \text{Total I.H.P.} = 4 \times 98$$

$$= 392.$$

The horse-power available for draw-bar pull

$$= 0.875 \times 392$$

$$= 343.$$

If P = the draw-bar pull in tons

The work done per revolution

$$= P \times \pi \times 6 \text{ ft.-tons.}$$

The useful energy supplied per revolution

$$= \frac{4 \times 60 \times \pi \times 100 \times 22}{2240 \times 12} \times 0.875 \text{ ft.-tons.}$$

Equating these, we get

$$P = \frac{240 \times \pi \times 100 \times 22 \times 0.875}{2240 \times 12 \times \pi \times 6}$$

$$= 2.86 \text{ tons.}$$

Mechanical Losses in a Steam Tractor

As an illustration of the method of applying the principle of the conservation of energy to a practical problem, we will briefly discuss an actual test of a steam tractor which was made in order to determine the mechanical efficiency, and to discover where the losses of power occurred.

The tractor is driven by a steam engine, fitted with a flywheel, and the motion is transmitted through gear wheels from the crank shaft to the driving wheels, as described in example (5), p. 194. A clutch is fitted between the crank shaft and the gear.

Tests were made while the tractor was drawing a train of loaded wagons along a level road. The power put in was measured by taking indicator diagrams from the cylinders. The power transmitted to the wagons was measured by the pull in the spring coupling between the tractor and the wagons.

For this purpose an apparatus was arranged to autographically draw a pull-distance curve, and at the same time equal intervals of time were recorded on the diagram.

The following are the figures for one test :

Indicated horse-power = 19·1.

Speed of crank shaft = 236 revolutions per minute.

Space-average of pull on wagons = 582 lbs.

Speed of tractor from diagram = 446 feet per minute.

Velocity ratio of gear = 11·53.

Diameter of driving wheels = 7 feet.

Horse-power transmitted to the wagons

$$= \frac{582 \times 446}{33,000}$$

$$= 7·9.$$

∴ Overall mechanical efficiency

$$= \frac{7·9}{19·1}$$

$$= 41·3 \text{ per cent.}$$

Horse-power lost in the tractor

$$= 19·1 - 7·9$$

$$= 11·2.$$

To find the slip of the driving wheels on the road, we have,

$$\text{Speed of the driving wheels} = \frac{236}{11·53} \text{ revolutions per minute}$$

$$= 20·4 \text{ revolutions per minute.}$$

$$\begin{aligned} \text{Speed of the circumference of driving wheels} \\ &= 20.4 \times 7 \times \pi \text{ feet per minute} \\ &= 450 \text{ feet per minute.} \end{aligned}$$

$$\text{Speed of the tractor} = 446 \text{ feet per minute.}$$

\therefore Percentage slip of the driving wheels

$$= \frac{450 - 446}{450} \times 100$$

$$= 0.9 \text{ per cent.}$$

The total mechanical losses in the tractor consist of the following items :

- (1) Engine friction loss.
- (2) Gear friction loss.
- (3) Friction loss of the driving wheels on the road and other resistances to motion (traction loss).

(1) In order to determine the engine friction the clutch was disengaged and an absorption brake fitted on the flywheel. A number of tests of the indicated horse-power and the flywheel horse-power were taken.

These tests shewed that the power lost in engine friction was practically constant and equal to 3.3 horse-power.

(2) To determine the gear loss the total horse-power lost between the cylinders and the driving wheels was estimated. This was effected by jacking up the tractor, and fitting a brake-ring and an absorption brake on one of the driving wheels.

From a series of tests it was found that the brake horse-power was related to the indicated horse-power as follows :

$$\text{Brake horse-power} = 0.925 (\text{indicated horse-power}) - 3.06.$$

For indicated horse-power = 19.1, we have,

$$\begin{aligned} \text{Brake horse-power} &= 0.925 \times 19.1 - 3.06 \\ &= 17.66 - 3.06 \\ &= 14.6. \end{aligned}$$

$$\begin{aligned} \text{The horse-power transmitted to the gear} \\ &= 19.1 - 3.3 \\ &= 15.8. \end{aligned}$$

$$\begin{aligned} \text{The horse-power lost in friction of the gear} \\ &= 15.8 - 14.6 \\ &= 1.2. \end{aligned}$$

$$\begin{aligned} \text{The efficiency of the gearing} &= \frac{14.6}{15.8} \\ &= 92.5 \text{ per cent.} \end{aligned}$$

$$\begin{aligned} (3) \text{ The horse-power given to the wagons} \\ &= 7.9. \end{aligned}$$

$$\begin{aligned} \therefore \text{Horse-power wasted in tractor road-friction and resistance} \\ &= 14.6 - 7.9 \\ &= 6.7. \end{aligned}$$

Summary of Losses

Input.		19.1 H.P.
Output.	Engine Friction	3.3 H.P.
	Gear Friction	1.2 H.P.
	Traction Loss	6.7 H.P.
	Transmitted to Wagons	7.9 H.P.
	Total	19.1 H.P.

Pelton Water Wheel

In a Pelton Wheel a number of buckets are arranged round the rim of a disc, and a jet of water, moving with a high velocity, impinges tangentially on the buckets. The reaction to the tangential pressure required to change the momentum of the water, provides the turning moment on the wheel.

A diagrammatic sketch of the wheel is shewn in fig. 120, and an enlarged sectional plan of one bucket is shewn also in the figure.

Let a = the area of the nozzle in sq. feet.

u = linear speed of the buckets in feet per second.

v = the velocity of the water as it issues from the nozzle in feet per second.

ρ = the density of the water in lbs. per cubic foot.

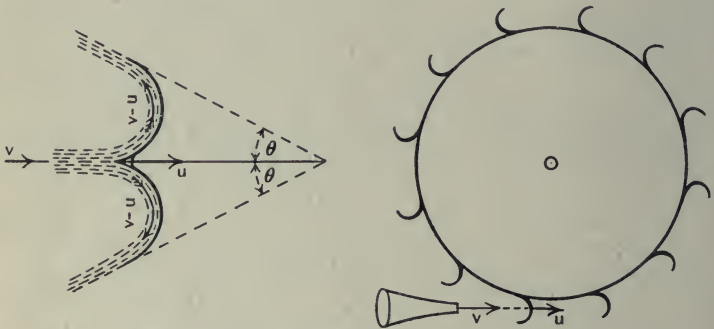

Fig. 120.

The tangential pressure on the wheel

= the change of momentum of the water per second

= the mass of water impinging per second \times the change of velocity.

The velocity of the water, relative to the bucket, just before it impinges is $(v - u)$.

In the absence of friction, this will also be the magnitude of the relative velocity of water and bucket at any point of the bucket. The direction will be changed by the normal pressure but this cannot affect the relative tangential velocity.

The final velocity of the water relative to the bucket in the direction of the jet = $-(v - u) \cos \theta$.

∴ The final velocity of the water relative to the fixed nozzle

$$= -(v - u) \cos \theta + u$$

$$= u (1 + \cos \theta) - v.$$

∴ The change of velocity in the direction of the jet

$$= v - \{u (1 + \cos \theta) - v\}$$

$$= 2v - u (1 + \cos \theta).$$

In practice θ is made very small, just sufficient to allow the water leaving to clear the wheel. Take $\theta = 0$.

The change of velocity in the direction of the jet = $2(v - u)$.

The quantity of water impinging on one bucket per second depends upon the relative velocity, and = $\rho a (v - u)$ lbs.

With a number of buckets, neglecting splash, we may assume that all the water impinges on the wheel.

∴ The mass of water impinging per second

$$= \rho a v \text{ lbs.}$$

The tangential pressure on the wheel

$$= \rho a v \times 2(v - u) \text{ abs. units}$$

$$= \frac{2\rho a v (v - u)}{g} \text{ lbs. wt.}$$

The work done on the wheel per second

$$= \frac{2\rho a v (v - u)}{g} \times u \text{ ft.-lbs.}$$

The energy supplied to the wheel per second

$$= \frac{1}{2} \rho a v \frac{v^2}{g}$$

$$= \frac{\rho a v^3}{2g} \text{ ft.-lbs.}$$

∴ The efficiency = $\frac{2\rho a v (v - u) u}{\rho a v^3}$

$$= \frac{2(v - u) u}{v^2}$$

Let ω = the angular velocity of the body at the instant considered, and r = the distance AG.

Then the relative velocity of A to G = ωr , and is perpendicular to AG.

Draw AB perpendicular to GA to represent ωr , and draw BC to represent v .

Then AC will represent u , and we have

$$\overline{AC} = \overline{AB} + \overline{BC},$$

or
$$u^2 = \omega^2 r^2 + v^2 + 2\omega r \cdot v \cdot \cos \phi.$$

Draw AN perpendicular to the direction of motion of G. Then AN is perpendicular to BC, and AB is perpendicular to AG.

$$\therefore \widehat{GAN} = \phi$$

and
$$r \cos \phi = AN.$$

If δm is the mass of a particle of the body at A, the kinetic energy of it

$$= \frac{1}{2} \delta m \cdot u^2.$$

For the whole body we get

$$\begin{aligned} \text{The kinetic energy} &= \sum \frac{1}{2} \delta m \cdot u^2 \\ &= \sum \frac{1}{2} \delta m (\omega^2 r^2 + v^2 + 2\omega v \cdot AN) \\ &= \frac{\omega^2}{2} \sum r^2 \delta m + \frac{v^2}{2} \sum \delta m + 2\omega v \sum \delta m \cdot AN. \end{aligned}$$

$\sum r^2 \delta m$ = the moment of inertia (**I**) of the body about an axis through G.

$\sum \delta m$ = the total mass **M**.

$\sum \delta m \cdot AN$ = the moment of each particle about the axis GN = zero, since G is the centre of gravity.

\therefore The kinetic energy of the body

$$= \frac{1}{2} \mathbf{I} \omega^2 + \frac{1}{2} \mathbf{M} v^2.$$

We may express this in words thus :

The total kinetic energy of a body moving in a plane equals the kinetic energy of the whole mass moving with the velocity of the centre of gravity plus the kinetic energy due to rotation about the centre of gravity.

Example (7). *In the arrangement shewn in fig. 122, each of the pulleys has a mass w , a radius r , and a radius of gyration k . If when left to itself the mass M descends and raises mass m , find the velocity of M when it has fallen a distance h from rest.*

Using the principle of the conservation of energy we may write,

the loss of potential energy = the gain of kinetic energy.

Let v = the velocity of M after descending a distance h .

The mass m and the pulley B will have ascended a distance $\frac{h}{2}$, and their linear velocity will be $\frac{v}{2}$.

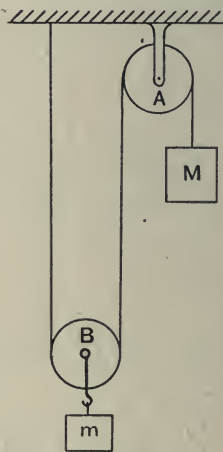

Fig. 122.

The angular velocity of pulley A will be $\frac{v}{r}$.

„ „ „ „ B „ $\frac{v}{2r}$.

We have then,

$$Mgh - (m+w)g \frac{h}{2} = \frac{1}{2} Mv^2 + \frac{1}{2} (m+w) \frac{v^2}{4} + \frac{1}{2} wk^2 \frac{v^2}{r^2} + \frac{1}{2} wk^2 \frac{v^2}{4r^2},$$

i.e.
$$v^2 \left\{ M + \frac{m}{4} + \frac{w}{4} + \frac{5wk^2}{4r^2} \right\} = (2M - m - w)gh,$$

or
$$v = \left\{ \frac{(2M - m - w)gh}{\left(M + \frac{m}{4} + \frac{w}{4} + \frac{5wk^2}{4r^2} \right)} \right\}^{\frac{1}{2}}.$$

Example (8). A wagon of total mass M has four wheels, each of mass m , radius r , and radius of gyration k . Shew that the effect of the rotation of the wheels is the same as that of an increase of mass equal to $\frac{4mk^2}{r^2}$.

Let the speed of the wagon be increased from u to v by the application of a constant accelerating force F in the direction of motion.

We may equate the work done by this force to the gain of kinetic energy.

Initially.

The kinetic energy of the wagon without the wheels

$$= \frac{1}{2} (M - 4m) u^2,$$

The kinetic energy of the wheels $= 4 \left\{ \frac{1}{2} m u^2 + \frac{1}{2} m k^2 \cdot \frac{u^2}{r^2} \right\}$, since

the angular velocity of the wheels is $\frac{u}{r}$.

\therefore The total kinetic energy $= \frac{1}{2} M u^2 + 2m \frac{k^2}{r^2} \cdot u^2$

$$= \frac{1}{2} \left(M + 4m \frac{k^2}{r^2} \right) u^2.$$

Finally.

The total kinetic energy $= \frac{1}{2} \left(M + 4m \frac{k^2}{r^2} \right) v^2.$

If s is the distance, and t the time for the change of velocity,

$$F \cdot s = \frac{1}{2} \left(M + \frac{4mk^2}{r^2} \right) (v^2 - u^2) \dots\dots\dots(1).$$

With the wheels locked we should have

$$F \cdot s = \frac{1}{2} M (v^2 - u^2),$$

assuming the same accelerating force to act.

\therefore The rotational inertia of the wheel is equivalent to an additional mass of $\frac{4mk^2}{r^2}$.

We may find the acceleration thus :

$$\text{From (1).} \quad F \cdot s = \frac{1}{2} \left(M + \frac{4mk^2}{r^2} \right) (v-u)(v+u).$$

But

$$\frac{v+u}{2} \cdot t = s,$$

$$\begin{aligned} \therefore F &= \left(M + \frac{4mk^2}{r^2} \right) \left(\frac{v-u}{t} \right) \\ &= \left(M + \frac{4mk^2}{r^2} \right) \times \text{acceleration.} \end{aligned}$$

$$\text{The acceleration} = \frac{F}{M + \frac{4mk^2}{r^2}}.$$

Examples. Chapter IX

1. It is required to transmit 50 horse-power from a pulley, 36 inches in diameter, running at 250 revolutions per minute. The belt is $\frac{1}{2}$ inch thick, and the permissible stress in the material is 600 lbs. per square inch. Find the proper width of the belt, on the assumption that the tension in the tight portion of the belt is twice that in the slack portion.

2. Shew that the horse-power delivered by a belt to a pulley of diameter D feet, running at N revolutions per minute, is given by

$$\frac{(T_1 - T_2) D \cdot N}{10500},$$

where T_1 and T_2 are the tensions in lbs. in the two sides of the belt.

Power is transmitted from a pulley A to a pulley B , and in order to measure the power the belt is arranged as shewn in fig. 123.

If the weight W attached to the light jockey pulley P is 150 lbs. and the spring balance attached to the light jockey pulley Q reads 70 lbs., find the horse-power transmitted when the speed of B is 200 revolutions per minute and its diameter is 9 inches.

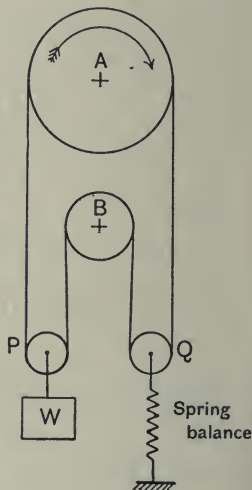

Fig. 123.

3. A flywheel, of mass 10 tons, is rotating 40 times per minute and the mean diameter of its rim is 19 feet. Express its energy as the fraction of a horse-power-hour.

Find the difference of the tensions in belting passing over the flywheel which would reduce it to rest in 10 minutes, taking the outer diameter of the flywheel as 20 feet.

4. Fig. 124 shews an absorption brake arranged for measuring the horse-power given out by a water turbine. When the brake was arranged on a pulley, which was quite free to rotate without friction, the spring balance read 4 lbs. If the brake pulley of the turbine is rotating at 500 revolutions per minute, and the spring balance reads 36 lbs. find the horse-power given out.

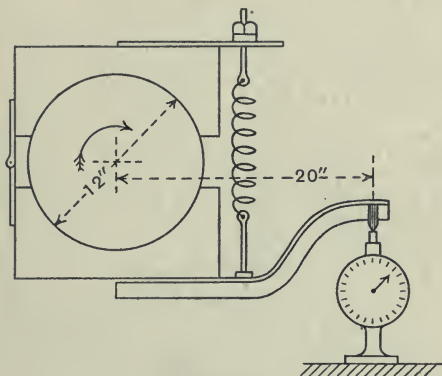

Fig. 124.

5. The table of a planing machine has a rack fixed to its underside, and takes its motion, along the bed of the machine, from a pinion which gears with the rack. The pinion has 14 teeth of $1\frac{1}{2}$ inch circumferential pitch, and to its axle is keyed a wheel of 68 teeth, which is driven from the pulley shaft through a wheel of 17 teeth. If the pulley shaft is running at a speed of 90 revolutions per minute, what is the linear speed of the table in feet per minute?

The table weighs 1000 lbs., and the coefficient of friction between the table and the bed is 0.12. If no power is lost in the gear, what torque must be applied to the pulley shaft in order to move the table along the bed?

6. The moving block of a tackle has two sheaves and the fixed block three sheaves. For raising a load the relation of the effort P to the load W is given by $P = \frac{W}{G} \left(1 + \frac{n}{8} \right)$, where G is the velocity ratio, and n is the number of sheaves round which the rope is wrapped.

Sketch the arrangement, and find the efficiency and the effort, when a load of 10 tons is raised.

What value of P would you expect to be required to slowly lower 10 tons?

7. The sketch, fig. 125, shews the mechanism of a coining press, in which pressure is exerted on the piece D by a pull at the end A of a bell-crank lever ABC pivoted at B . The direction of the pull is perpendicular to BD , and D is constrained to move along BD .

Determine, graphically, the velocity ratio of D to A . Neglecting friction, what pull is required at A to move D against a thrust of 2 tons?

[Prick the figure through to your paper.]

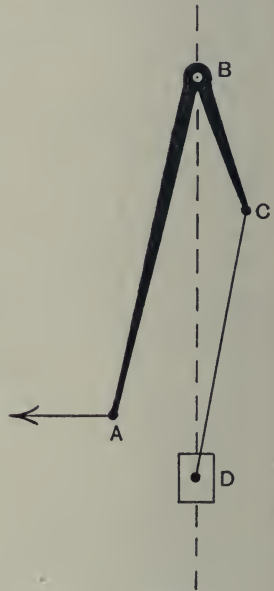

Fig. 125.

8. A winch has four parallel shafts A , B , C and D . On shaft A there is a pinion with 11 teeth, which meshes with a wheel with 39 teeth on shaft B . Compound with this wheel, a pinion of 12 teeth meshes with a wheel with 50 teeth on shaft C . This shaft has a pinion with 11 teeth meshing with a wheel with 70 teeth on the drum shaft D . The external diameter of the drum is 10 inches, and the winding rope has a circumference of $2\frac{1}{2}$ inches.

If the pull in the rope being wound on the drum is 5 tons, and the efficiency of the machine is 75 per cent., what tangential force will have to be applied to a handle of 15 inches' effective radius (i) if it is fixed on shaft A , (ii) if it is fixed on shaft B ?

9. A flywheel, 6 feet in diameter and weighing half a ton, is supported midway between two bearings on a shaft of 4 inches diameter. Power is delivered to the shaft at the rate of 25 horse-power, and drives the flywheel

at 150 revolutions per minute against the friction of a strap which passes over the upper half of the circumference, and carries 300 lbs. at one end and 25 lbs. at the other. Find how much of the power is absorbed by the friction of the strap, and how much by the friction of the bearings. Find also the total thrust, and the resultant frictional force, on each bearing.

10. Define the terms velocity ratio, mechanical advantage, efficiency, and shew that the efficiency is equal to the mechanical advantage divided by the velocity ratio.

In a test of a crane with a velocity ratio of 280 the following values of load and effort were observed:

Load in tons	1	2	3	4	5	6
Efforts in lbs.	31	49	67·5	86	104·5	123

Plot the values given and obtain the relation between load and effort. Plot also a curve shewing the efficiency for the above loads.

11. Shew how to find the crank effort in a single cylinder engine for any given crosshead thrust. The crank of an engine is 8 inches, the connecting rod 30 inches; the crosshead thrusts at quarter stroke, at half stroke, and at three-quarter stroke are 4000, 2500, and 600 lbs. wt. respectively. Find the corresponding turning moments on the crank.

12. An electric motor has keyed to its spindle a wheel A of 14 teeth which gears with a wheel B of 70 teeth. Compound with B is a wheel C of 13 teeth which gears with a wheel D of 48 teeth. Compound with D is a wheel E of 23 teeth which gears with a wheel F of 54 teeth. Wheel F is keyed to the axle of the chain barrel of a crane, the effective diameter of which is 15 inches. Find the speed of the motor when the chain is being wound on the barrel at a rate of 20 feet per minute.

If a load of 10 tons is being raised at this speed, what power will be taken by the motor, assuming the combined efficiency of the motor and crane is 45 per cent.?

13. A steam engine is driving a dynamo by a belt and is running at 120 revolutions per minute. The diameter of the driving pulley is 3 feet, and the tensions in the tight and slack portions of the belt are 2000 lbs. and 800 lbs. respectively. What horse-power is the engine delivering?

14. A sliding door of a railway carriage is 3 feet broad and weighs 250 lbs. It closes in the direction of motion of the train. The door is fully open and the train travelling at 20 miles per hour when the latter starts slowing up with a constant retardation of 2 feet per second per second. If the resistance to motion between the door and the carriage is constant and equal to 4 lbs., find the velocity, relative to the train, with which the door closes. If the catch on the door automatically couples it when it closes, find the impulse and the energy dissipated.

15. A locomotive with two cylinders each 19 inches diameter, 22 inches stroke, and driving wheels $5\frac{1}{2}$ feet diameter, is working with a mean steam pressure in the cylinders of 135 lbs. per sq. inch. Find the tractive force at the rails, assuming that 10 per cent. of the power developed is wasted in engine friction. Calculate also the greatest load, including the engine, which can be taken up an incline of 1 in 150 at 10 miles per hour if the resistance per ton at this speed is 6.9 lbs.

16. The pressure in one end of a steam engine cylinder, during a revolution, is shewn on the indicator diagram below, fig. 126. The piston area is 80 sq. inches, the stroke is 15 inches and the engine runs at 120 revolutions per minute. Determine the average effective pressure during a revolution, the work done per minute, and the horse-power.

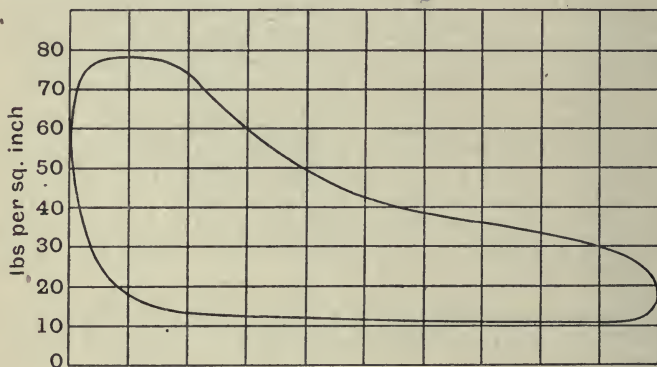

Fig. 126.

17. The engines of a steamer are developing 2500 indicated horse-power when the speed is steady and equal to 16 knots. If the overall efficiency is 60 per cent., find the total resistance to motion of the vessel in tons.

Assuming the total resistance varies as the square of the speed, find the new steady speed when the horse-power is increased to 3000, the overall efficiency remaining the same.

[1 knot = 6080 feet per hour.]

18. A gas engine is speeding up under no load, and at the beginning of one cycle the speed is 100 revolutions per minute. The indicator diagram for the cycle is given below. Find the work done during the cycle, and the speed of the engine at the end of the cycle, neglecting friction.

Diameter of piston 18 inches. Length of stroke 2 feet. Moment of inertia of flywheel 107 tons ft.² Scale for pressure, 1 inch = 180 lbs. per sq. in.

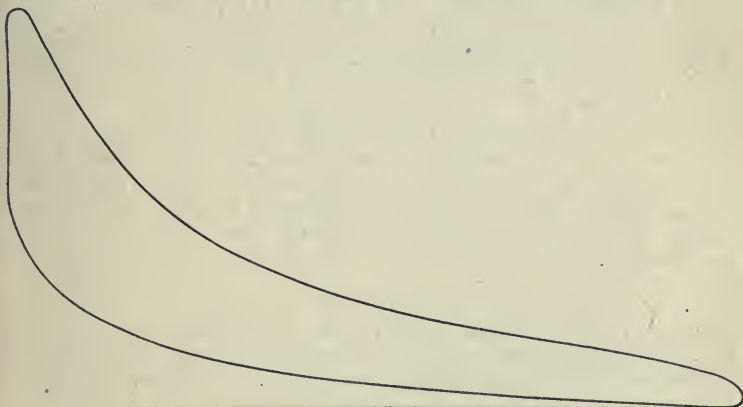

Fig. 127.

19. In a single cylinder steam engine, the diameters of the piston and the piston rod are respectively 11 inches and $1\frac{1}{2}$ inches, the length of stroke 1 foot, and the speed 197 revolutions per minute. The mean pressure on each side of the piston is found from the indicator diagrams to be 16.5 lbs. per sq. in. Find the indicated horse-power.

If the engine is driving a dynamo, the output of which is 10.8 kilowatts and the efficiency 95 per cent., find the horse-power wasted in friction in the engine.

[0.746 kilowatt = 1 horse-power.]

20. In order to determine the efficiency of some gearing, power was transmitted through it from a steam engine. The indicated horse-power of the engine and the horse-power given out by the gearing to a brake wheel

were measured. Previous experiment shewed that the horse-power wasted in friction in the engine was practically constant and equal to 2·6.

Find the efficiency of the gearing from the following data :

I.H.P. of the engine, 24·2.

Speed of engine shaft, 240 r.p.m.

Velocity ratio (crank shaft to brake wheel), 11·7.

Torque on brake wheel, 4750 lbs. ft.

21. A motor-car delivers 25 horse-power to its shaft. The engine shaft is geared down to the back axle in the ratio 4 to 1, and 12 per cent. of the shaft-power is lost in the gear. The car wheels are 28 inches in diameter, and the car is running at 32 miles per hour. Find the torque on the engine shaft, the torque on the back axle, and the propulsive force between the road and the driving wheels.

The car runs up a slope of 1 in 25, and the gear is changed so that the reduction ratio is 6 to 1, and the gear loss is now 25 per cent. of the shaft power. If the torque on the engine shaft remains constant, while the resistance to motion is proportional to the square of the speed, find the uniform velocity with which the car ascends the slope. The weight of the car is 2500 lbs.

22. A gas engine is working at 10 indicated horse-power and at 200 revolutions per minute when the gas is suddenly cut off. Assuming the torque due to the brake and other resistances remain constant, find the number of revolutions the engine makes before coming to rest. The moment of inertia of the flywheels is 3500 lbs. feet².

23. What is the rate in horse-power at which energy can be delivered by a stream, 2 square feet in section, flowing at the rate of 8 feet per second? (1 cu. ft. of water weighs 62½ lbs.)

If the stream is used to drive a water wheel turning at a constant rate of 30 revolutions per minute and exerts on it a constant couple of 120 in feet and lbs., what is the efficiency of the arrangement?

24. Flat vanes are arranged radially round the circumference of a wheel to form a water turbine. A jet of water impinges on the vanes, the direction of the jet being tangential to the wheel and at a distance of 9 inches from the centre. The velocity of the jet is 50 feet per second, and the discharge is 20 cubic feet per minute. Find what should be the speed of the wheel for maximum horse-power, and the theoretical horse-power at that speed.

25. The effective diameter of a Pelton wheel is 40 inches and the nozzle area 12.5 square inches. It is supplied with 672 cubic feet of water per minute and runs at a speed of 380 revolutions per minute. Find the theoretical efficiency assuming the direction of motion of the water completely reversed.

If the horse-power given out is 250, what is the actual efficiency?

26. A moving staircase has a speed of 100 feet per minute, and rises 30 feet vertically in 50 feet horizontally. 180 people use the staircase per minute, and the average weight per person is 9 stones. When they step on at the bottom, they do so at a speed relative to the ground of 80 feet per minute in the direction of motion of the staircase. They remain at rest relatively to the staircase while moving horizontally at the bottom and top, but during the rise they climb relatively to the staircase at a rate of 60 feet vertically per minute. At the top they step off in the direction of motion with a speed of 100 feet per minute relative to the ground.

Find the horse-power required to maintain the motion of the staircase, neglecting friction.

27. Work is done at the rate of 17.5 horse-power in driving a car, which weighs 8 tons, up an incline of 1 in 20 at a speed of 6 miles per hour. If the frictional resistances remain constant, find the acceleration in feet per second per second when the car is allowed to run freely down the same incline.

28. In a horse car the energy of rotation of the wheels is a negligible fraction of the total energy of the car, but in an electric car the energy of the rotation of armatures, gear wheels, etc., is appreciable. Given two cars, one in which the rotational energy may be neglected, and one in which it amounts to one-tenth of the total energy of the car, shew that, neglecting friction, their accelerations down a given slope are in the ratio of 10 to 9.

Call the two cars A and B and suppose that their total weights are equal, then find the acceleration down a slope of inclination α (1) of car A running alone, (2) of car B running alone, (3) of A and B running coupled.

29. A pump is driven by an electric motor by means of a belt. When the motor is absorbing 20 horse-power, the pump lifts 400 gallons of water per minute through a height of 80 feet. What is the efficiency of the plant as a whole? Neglect the kinetic energy of the water. 1 gallon of water weighs 10 lbs.

If the motor has an efficiency of 88 per cent., find the efficiency of the pump, neglecting any loss of power in the belt.

In addition to raising the water through 80 feet the pump is required to deliver it against a pressure of 20 lbs. per sq. inch. Assuming that the efficiency of the plant is the same as in the previous case, find what power must be supplied to the motor.

30. A steam engine has a stroke of 10 inches, and is running uniformly at a speed of 250 revolutions per minute. The piston weighs 80 lbs. Neglecting the obliquity of the connecting rod, find how much energy is stored in the piston (1) between dead centre and quarter stroke, and (2) between quarter stroke and half stroke.

Also find the amount of energy stored in the piston while the crank moves through an angle of 45° from dead centre.

MISCELLANEOUS EXAMPLES

The following examples are not arranged in order of difficulty nor according to the principle involved.

1. Four members of a frame, A, B, C and D, all lie in one plane, and meet at a point. Members B, C and D make angles, all measured in the same direction, of 90° , 210° , $257\frac{1}{2}^\circ$ respectively, with the member A. The pulls in the members C and D are 4.7 tons and 5 tons respectively. Find the pulls in members A and B (1) graphically, (2) by calculation.

2. In order to find the height of an airship which is travelling over the sea, a gun is fired from the ship and the time between the firing of the gun and the receipt of the sound reflected from the sea is noted. The time in one case was 15.8 seconds. What was the height of the airship?

If five minutes later the time was 16.6 seconds, what was the vertical velocity assuming it to be uniform?

[Velocity of sound in air = 1080 feet per second.]

3. A section of a railway between two points A and B distant 2000 yards apart, is given by the following table which shews the elevation above A for every 200 yards :

Distances in yds.	A	200	400	600	800	1000	1200	1400	1600	1800	B
Heights in ft.	0	$3\frac{1}{2}$	10	17	25	32	38	40	$36\frac{1}{2}$	$28\frac{1}{2}$	16

A train, the mass of which exclusive of the engine is 300 tons, passes A at a speed of 30 miles per hour. The locomotive exerts a constant draw-bar pull of 7000 lbs., and the train resistance may be taken as 15 lbs. per ton. Draw a curve shewing the variation in speed as the train advances from A to B.

4. Shew that if a body is moving in a circular path of radius r feet with a uniform speed of ω radians per second, then it has an acceleration towards the centre equal to $\omega^2 r$ feet per second per second.

The mean diameter of a cast-iron flywheel is 4 ft. 3 in. What is the maximum speed of rotation, expressed in revolutions per minute, if the mean stress in the rim is not to exceed $\frac{1}{2}$ ton per sq. inch?

[1 cubic foot of cast-iron weighs 460 lbs.]

5. The relation between the tractive force on a car weighing 1 ton and the time is as follows :

Time in secs.	0	5	10	15	20	25	30
Force in lbs. wt.	110	108	104	98	88	78	70

If the car starts from rest and the resistances to motion are equivalent to a force of 40 lbs., draw the acceleration-time curve for the motion and find the velocity at the end of the 30 seconds.

6. A train A, moving with a constant speed of 30 miles per hour, is passing another train B, which is at rest on a parallel track. At the instant when the engines of the two trains are opposite, the train B starts with a constant acceleration of 2 feet per second per second. What length of time will elapse before the two trains again occupy the same relative position? If the train B is 100 yards long, at what distance from its starting point will it have completely overtaken train A?

7. Below is an indicator diagram for one end of one cylinder of a locomotive, the spring used being such that 1 inch on the diagram represents 150 lbs. per sq. inch. The diameter of the cylinder is 20 inches, the stroke 22 inches, and the speed 240 revolutions per minute. Find the indicated horse-power represented by the diagram.

[Prick the diagram through to your paper.]

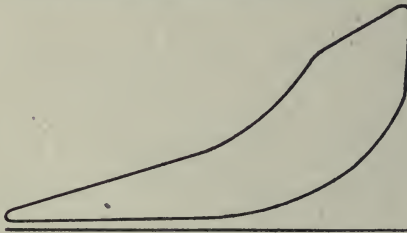

Fig. 128.

8. A uniform disc, 18 inches in diameter, and weighing 30 lbs., is keyed to a spindle of 1 inch diameter and is mounted on frictionless bearings. A light cord is wound round the spindle and carries a weight of 1 lb. at its free end. Find the angular acceleration of the disc, and the linear acceleration of the weight when the system is in motion.

9. One part of the track of a switch-back railway consists of a complete vertical circle of 20 feet diameter. Neglecting friction, find the minimum velocity with which a car must start on its journey round the circle if it is to keep the rails. How high must the starting point of the track be above the top of the circular portion in order that this minimum velocity may be attained? The rotational inertia of the wheels may be neglected.

10. A shell is fired so that at the highest point of its flight it just passes over a mountain 3000 feet high and distant 5 miles from the point of projection. Find the ratio of the horizontal component of the velocity of projection to the vertical component, and the values of these components.

If the shell weighs 350 lbs., what is its kinetic energy (1) as it leaves the gun, (2) as it passes through the highest point of its flight?

11. The crank of an engine is 9 inches, the connecting rod 3 feet, and the line of stroke of the piston passes through the axis of the crank shaft. The speed of the crank is 240 revolutions per minute. Find, graphically, the velocity of the piston at one-quarter of the distance from each end of the stroke.

For the same two positions of the piston, find the velocity of rubbing between the connecting rod and crank pin, if the latter is $2\frac{1}{2}$ inches in diameter.

12. In a double-acting steam engine the stroke is 12 inches long and the connecting rod may be assumed infinitely long. The effective thrust on the crosshead due to the steam pressure is constant and equal to 2000 lbs. Shew that the torque on the crank shaft produced by this thrust varies as the sine of the angle turned through by the crank from the dead centre position.

Plot a curve shewing the turning moment on the crank and the angle turned through by the crank.

13. In the previous question, the engine is working against a constant resisting torque and the mean speed is 240 revolutions per minute. Find the moment of inertia of the flywheel required to limit the speed fluctuation to 3 per cent. above or below the mean speed.

14. A gunboat with hydraulic jet propulsion takes water in through vertical openings amidships and discharges it astern. A discharge of 5.2 tons per second at a velocity of 29 feet per second relative to the boat gave a speed of 9.3 knots. Find the resistance to motion of the boat.

15. A casting, the shape of which is an equilateral triangle with a cylindrical boss at each corner, is bolted to the face-plate of a lathe, the axis of one of the bosses coinciding with the axis of the face-plate. The length of the sides of the casting, measured from centre to centre of the bosses, is 10 inches, and the weight is 6 lbs. Find where on the face-plate a mass of 2 lbs. should be bolted in order to balance the centrifugal force of the casting.

16. A flexible belt weighing $\frac{1}{2}$ lb. per foot connects two equal pulleys the centres of which are 10 feet apart. The diameter of the pulleys is 3 feet, and the moment of inertia of each is 110 lbs. ft. Find the couple required to uniformly increase the speed from 120 revolutions per minute to 240 revolutions per minute in 30 seconds.

17. A roundabout makes 3 revolutions per minute, and the horses are suspended from the roof at a distance of 15 feet from the centre by rods 8 feet long. What is (1) the angular velocity of the roundabout, (2) the speed of the points of suspension, (3) the speed of the horses?

18. A train weighing 100 tons starts from rest and the engine exerts a uniform pull of 3 tons against a road resistance of 15 lbs. per ton. In what time will the speed reach v feet per second, and how far will the train move in the time?

If steam is cut off and the brakes applied, with a retarding force of 20 tons, when the speed is v feet per second, how far and how long will the train run before coming to rest?

The train has to run a distance of 2 miles from stop to stop and the speed is not to exceed 45 miles an hour. How long will the journey take?

19. The balance wheel of a small clock weighs $\frac{1}{8}$ ounce and its radius of gyration is $\frac{3}{8}$ inch. The periodic time of oscillation is 1 second and its amplitude 180 degrees. What is the strength of the controlling spring expressed in inch-lbs. per radian? Find also the maximum energy stored in the spring at any time.

20. Explain clearly how it is that the pressure of a brake on the rim of the wheel of a vehicle produces a retarding force on the vehicle considered as a whole.

A railway truck, weighing 15 tons, is running freely at 20 miles an hour down an incline of 1 in 100 when brakes are applied equally to all four wheels

with a pressure of 1000 lbs. each. Taking the coefficient of friction between brake-block and wheel to be $\frac{1}{3}$, and neglecting other resistances to motion and also the inertia of the wheels, find how far down the incline the truck would travel after the application of the brakes. In what manner would the inertia of the wheels, if taken into account, affect the calculated value of the retarding force?

21. A cage, weighing 16 cwt. with its load of coal, is lifted from the bottom of a mine by a rope weighing 6 lbs. per yard. The rope is wound straight on to a drum 8 feet in diameter, and a constant torque of 4 tons ft. is applied to drive the drum. At the start there is a length of 210 feet of rope hanging vertical, and there is one complete turn of rope on the drum. The inertia of the drum itself may be neglected. Find how much work has been done when four more complete turns have been wound on the drum, and the velocity of the cage at that instant.

22. A marine turbine makes 165 revolutions per minute, and carries a screw whose blades measure 8 feet 8 inches from the centre of the shaft to the tip of the blade. Find the circumferential speed of the tip of the blade, and express it in feet per second and in miles per hour.

The wheel of a Laval turbine is 30 inches in diameter, and it runs at 10,500 revolutions per minute. Find the speed of a point on the rim.

23. A car starts from rest and its velocity has the following values at the times specified:

Time in secs.	1	2	3	4	5
Velocity in ft. per sec.	2	5	8.5	9.5	10

Plot the velocity-time curve and find the time-average of the velocity, and the total distance covered.

Find also the time-average of the acceleration, and its maximum value.

24. A body weighing 10 lbs. is moving with a simple harmonic motion, the length of its path being 12 inches, and the maximum velocity 8 feet per second. Draw the force-distance curve, and the force-time curve for the motion from the centre to one end of the path, and determine the space average and the time-average of the force.

25. The figure below shows a governor in which, at a speed of 120 revolutions, the sleeve remains at rest. For this speed, find the forces in the rods AB and BC, if the ball at B weighs 1 lb.

Assuming the sleeve at C does not move, at what speed will the stress in BC be zero?

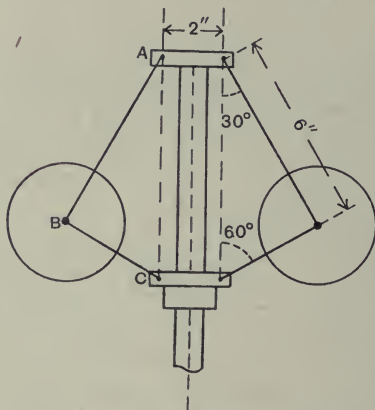

Fig. 129.

26. A bullet weighing $\frac{1}{2}$ ounce and travelling at 2000 feet per second is just held up by a fixed block of wood of length 36 inches in the direction of impact. A ballistic pendulum arranged as shown in fig. 92, p. 144, is made of the same wood. It is 30 inches long in the direction of impact and weighs 25 lbs. A bullet similar to the above and travelling with the same speed is fired into the pendulum. Find (1) the speed with which the bullet emerges, (2) the height the pendulum rises, (3) the kinetic energy imparted to the pendulum, (4) the energy wasted in heat, (5) the time taken for the bullet to pass through the pendulum. The pendulum may be assumed to remain at rest during the passage of the bullet through it.

27. What is the side pressure between a train weighing 300 tons and the rails when the train goes round a curve of 120 yards radius at the rate of 30 miles an hour, the rails being on the same level? What will the side pressure be if the rails are banked at an angle of 5° ?

28. A motor running at 600 revolutions per minute is belted to a machine, the ordinary fast and loose pulley arrangement being used, and the speed being reduced in the ratio 3 to 1. If the belt is suddenly shifted from the

loose to the fast pulley, find the speed of the machine shaft immediately after slipping has ceased. The moment of inertia of the armature shaft of the motor is 800 lbs. ft.², that of the machine shaft 400 lbs. ft.², and the inertia of the loose pulley and belt may be neglected.

29. A uniform plank 20 feet long has one end against a vertical wall, the other on a horizontal plane. The plank just starts skidding when the angle of inclination to the vertical is 30°. Assuming the resistance to motion down the vertical wall is negligibly small, and that along the horizontal plane it is constant, find the angular velocity of the plank at the instant it reaches the ground.

30. The motion of a point is the resultant of two simple harmonic motions in two directions at right angles to one another and of the same periodic time. Shew that the path of the point is an ellipse.

31. A ship lies at anchor, half a mile from the shore, in a stream running at 8 miles per hour. A boat starts from the shore, 1 mile higher up stream, and is rowed at right angles to the shore. At what speed must it be rowed in order that it may reach the ship?

Find also the speed required when the boat is rowed in a direction at right angles to the line joining its starting point to the ship.

If the greatest speed at which the boat can be rowed is 5 miles per hour, shew that it cannot reach the ship unless its starting point be at least 1100 yards higher up stream than the ship.

32. A bullet of mass m travelling at a certain speed is just stopped in a distance S by a fixed target, the resistance to penetration of which is constant. Shew that if the same bullet travelling horizontally with the same speed strikes a target of the same material as before, and of mass M , which is free to move horizontally, it will penetrate a distance $\frac{M}{M+m} S$. Find the time of penetration.

33. In a steam engine the crank is 6 inches long, the connecting rod 3 feet long, and the speed 200 revolutions per minute. Shew that the velocity in feet per second is approximately given by $10.47 \sin \theta + .87 \sin 2\theta$, where θ is the angle which the crank makes with the inner dead centre.

Find a similar expression for the acceleration of the piston.

34. In an engine driven by water pressure the crank AB is acted upon by three connecting rods BC , BD , BE . For the positions shewn in fig. 130, the thrusts in the rods are 40 lbs., 180 lbs., and 200 lbs. respectively. Find, graphically, the resultant force produced by these on the crank pin, and also its components parallel and perpendicular to the crank.

Check your results analytically, by resolving all the forces along and perpendicular to the crank.

[The figure may be pricked through to your paper.]

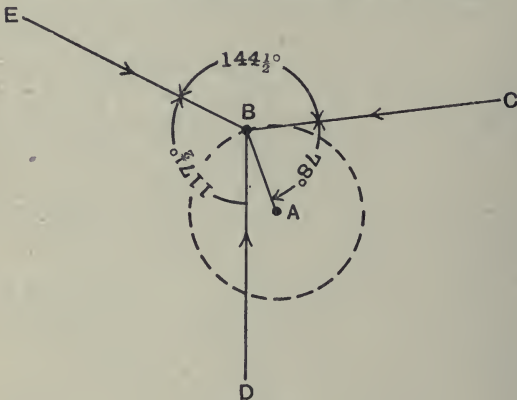

Fig. 130.

35. An engineer's pocket-book gives the following formula for the retarding force R required to stop a train travelling at V miles per hour in D feet, R being the force in percentage of the weight of the train.

$$R = 3.34 \frac{V^2}{D}.$$

Prove this formula.

36. In a small shaping machine the mechanism of which is shewn diagrammatically in fig. 131, the tool is fixed to the ram C . When the crank AB is inclined at 45° to the line of stroke the force at the cutting edge of the tool along the line of stroke is 500 pounds. Find the couple required on the crank, neglecting friction and the effect of inertia of the moving parts. Find, also, the length of stroke of the tool, and the ratio of time of cutting to time of return.

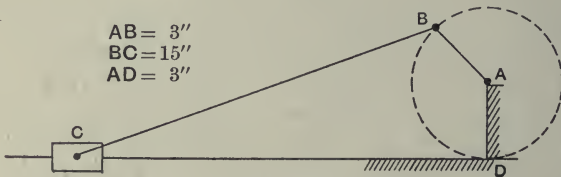

Fig. 131.

37. In an inclined railway the length of the track is 7017 feet and the gradient is uniform and equal to 1 in 9.75. The weight of an empty train is 19 tons, and it can carry a maximum load of 21 tons. Two trains are run simultaneously, one ascending and the other descending, the two being connected by a steel-wire rope which passes round a 10 foot pulley at the top. The pulley is rotated by a stationary engine. The weight of the rope is $2\frac{1}{2}$ lbs. per foot. Neglecting friction, find the varying torque required to steadily haul a full train up the incline, the descending train being empty.

If the journey takes 15 minutes, neglecting the power to start and stop, find the average horse-power.

38. In question 37 above, if the trains are started with a uniform acceleration so that they attain their speed in 6 seconds, what torque on the pulley will be required for accelerating? The moment of inertia of the pulley and the wheels of the train may be neglected.

39. A disc of 10 inches diameter is keyed eccentrically to a horizontal shaft, the distance between the centres being 3 inches. The disc presses against the underside of a horizontal plate, and is used as a cam to give a reciprocating vertical motion to the plate. Shew that the reciprocating motion is simple harmonic, and determine the length of the stroke. Find also the maximum velocity of the plate when the disc is rotating once in a second.

40. A car starts from rest and moves with a uniform acceleration of $1\frac{1}{8}$ feet per second per second. How long will it take to acquire a velocity of 20 miles per hour, and how many feet will it move in the time?

If the car weighs 2000 lbs. and the motion is on the level and against an external resistance of 30 lbs. wt. what is the value of the horizontal force between the car and the ground?

41. A weight moves as a conical pendulum, at the end of a string 3 feet long and makes 40 revolutions per minute. Find to the nearest degree the inclination of the string to the vertical.

A string whose length is l passes through a heavy ring and has its ends attached to two points, distant a apart in the same vertical line. Shew that when the ring rotates in a horizontal circle the portion of string between the ring and the lower point of support will be horizontal if the angular velocity is given by $\omega^2 = 2g \frac{l^2}{a(l^2 - a^2)}$.

42. A traction engine weighing 8 tons is hauling a loaded wagon weighing 18 tons along a level road, at 5 miles per hour. There is a spring coupling between the engine and the wagon, and the extension of the spring shews that the pull on the wagon is 600 lbs. At what rate in horse-power is work being done in hauling the wagon?

If the resistance per ton is the same for the engine as for the wagon, what is the total resistance overcome by the engine and at what rate, in horse-power, is the engine working?

43. The motion of a body moving in a straight path is given by $s = 10 + 8t + 6t^2$, s being measured in feet and t in seconds. Plot the distance-time curve, the velocity-time curve, and the velocity-space curve, for the first 6 seconds. For this period find the time-average and the space-average of the velocity.

44. A body swings about a fixed horizontal axis through an angle α on either side of its position of equilibrium. Prove that for different values of α the maximum angular velocity of the body is proportional to $\sin \frac{\alpha}{2}$.

A body makes complete revolutions about a fixed horizontal axis, about which its radius of gyration is k , and the centre of gravity of the body is at a distance c from the axis. If the greatest and least angular velocities are $\frac{1}{2}$ per cent. greater and $\frac{1}{2}$ per cent. less than ω , prove that $\omega = \sqrt{\frac{200gc}{k^2}}$.

45. What do you understand by a curve of crank effort? Shew how to determine the crank effort corresponding to a given piston-thrust in any position of the crank of a single-cylinder engine.

Determine the crank effort for a piston-thrust of 100 lbs. when the crank makes (1) 45° , (2) 90° , (3) 135° with the line of stroke, the lengths of the crank and connecting rod being 6 inches and 24 inches.

46. A cage weighing 1 ton is being raised from the bottom of a shaft 200 feet deep by means of a drum and chain. The chain weighs 5 lbs. per foot. Draw a curve of the effort exerted at the lifting drum, throughout the motion, and find the whole work done during the lift. If the cage is raised at a uniform speed in $2\frac{1}{2}$ minutes, find the maximum and the mean values of the horse-power exerted at the drum.

47. Two links AB and CD are pivoted at A and C and a weight of 10 lbs. hangs from point E in the link BD, as shewn in fig. 132. Prick the figure through to your paper, and taking 2 inches to represent the velocity of the

point D, find the angular velocity ratio of AB and CD, and the position of the point in BD which has a vertical motion.

Find also what couple must be applied to CD in order to just support the weight.

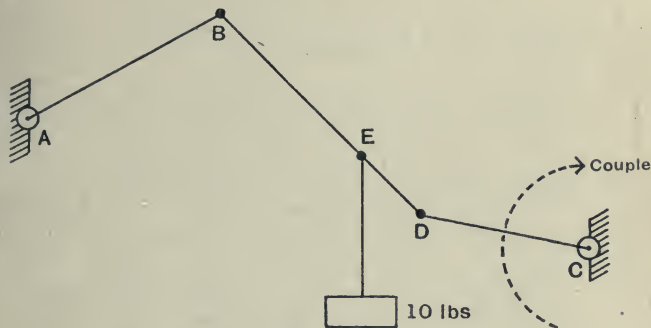

Fig. 132.

48. A uniform heavy rod is supported in a horizontal position, being pivoted at one point in its length and attached at another point to the end of a spring which hangs from a fixed point vertically above the point of attachment. If a is the distance between the points of support, k the radius of gyration about the pivot, and d the extension of the spring when it carries a weight equal to the weight of the rod, shew that the period of small oscillations in a vertical plane is

$$2\pi \frac{k}{a} \cdot \sqrt{\frac{d}{g}}$$

If a sliding weight is moved from the pivot towards the spring how is the period affected?

49. The engines of a steamship develop 20,500 I.H.P. Of the power developed 15 per cent. is lost in engine and shaft friction, and 30 per cent. in slip and friction of the propeller. If the speed of the ship is 20 knots what is the total resistance to its motion?

If the resistance vary as the square of the speed, what I.H.P. is required for a speed of 22 knots?

1 knot is 6080 feet per hour.

50. A centrifugal pump lifts water at the rate of 6000 gallons per minute and discharges it at a level of 10 feet above the level of suction. The discharge pipe is 18 inches in diameter and runs just half full. Find how much

work is spent per minute (1) in lifting the water, (2) in imparting kinetic energy to it.

The pump runs at 460 revolutions per minute and one-fifth of the power supplied to it is wasted in friction, slip, etc. What is the torque on its shaft?

51. A train starts from rest and its velocity during the first 90 seconds of its motion is given in the following table:

Time from start in secs.	15	30	45	60	75	90
Velocity in ft. per sec.	5.2	10	14.1	17.3	19.3	20

Plot the velocity-time curve, and determine the distance travelled in the given time.

From the curve deduce the value of the starting acceleration and plot a curve shewing approximately how the acceleration diminishes.

52. In a gas engine the maximum amount of energy which the two fly-wheels have to absorb and give out during running is equal to 3550 ft.-lbs. The mean speed of the engine is 200 revolutions per minute, and the moment of inertia of each wheel is equivalent to a mass of 692 lbs. acting at a radius of $2\frac{1}{2}$ feet. Find the greatest fluctuation of speed of the engine.

53. What is the length of a simple pendulum whose periodic time is 2.3 seconds?

How will the time-keeping of a pendulum clock be affected if it be taken to a place where " g " is decreased by 0.01 per cent.?

54. A balloon weighing 5 cwt. is moving horizontally at 100 feet from the ground when 50 lbs. of ballast is suddenly released. Neglecting the friction of the air, find how high the balloon will be when the ballast reaches the ground.

55. A shell is fired at an elevation of 15° so as to hit a mark 900 yards distant on a horizontal plane. Find its velocity of projection and its time of flight. Find also its height above the ground when it has travelled 600 yards horizontally.

56. A lifting gear consists of a train of toothed wheels as shewn in fig. 133, the intermediate wheels being keyed to the same axle. The gear is driven by a force P applied at the end of the handle AP , which is 18 inches long and is fixed to the wheel A . The load W is supported by a rope wound

round a drum of 4 inches diameter. The numbers of teeth are, on A 21, on B 60, on C 18, on D 70. Find the velocity ratio of the machine.

If a force P of 3 lbs. raises a load W of 200 lbs., shew that the efficiency is 66.7 per cent.

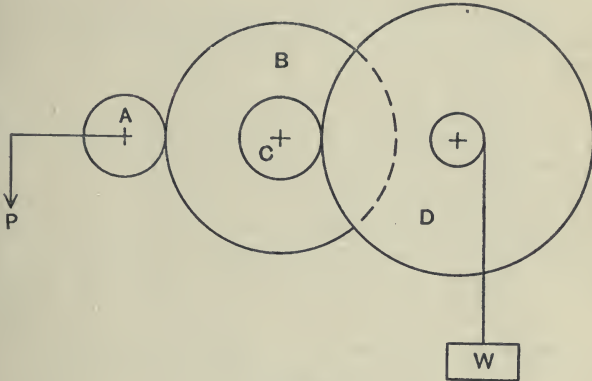

Fig. 133.

57. An engine running at 120 revolutions per minute has a pulley of 36 inches diameter which is belted to a pulley of 20 inches diameter on a countershaft. A second pulley on the countershaft is belted to a pulley of 12 inches diameter on a dynamo, and the dynamo is required to run at 720 revolutions per minute. Find the diameter of the second pulley on the countershaft.

The engine is delivering 50 horse-power to its belt, and 2 horse-power is lost in friction at the countershaft. Neglecting other losses, find the tension in each belt, assuming that in each case the tension in the tight portion of a belt is double that in the slack portion.

58. In an inward flow water turbine the external diameter of the rotor is 15 inches and the vanes are radial at the point of entry. The velocity of the water just before entry is 50 feet per second, and the speed of the rotor is 380 revolutions per minute.

At what angle of inclination with the tangent should the water enter if there is to be no shock?

Assuming no shock, the supply 500 cubic feet per minute, and the discharge radial, find the turning moment on the rotor.

59. Two trains start from a station along the same track, one 8 minutes after the other. Each has a constant acceleration until the maximum speed of 50 miles per hour is reached, 1 mile from the start. How far has the first train gone when the second train starts, and how far apart are they when both are running at the same speed?

If the second train, with the same acceleration, reaches a maximum speed of 60 miles an hour, at what distance from the starting point will it overtake the first?

60. A car weighing 22 cwt. is running on a level road at 12 miles an hour round a curve of 40 feet radius, measured to the centre of gravity of the car. What horizontal force perpendicular to the direction of motion must be exerted by the ground on the wheels of the car?

Assuming that the grip of the outer wheels is sufficient to prevent skidding, find at what speed the inner wheels will begin to lift off the ground. The width of the wheel base is 3 feet 9 inches and the centre of gravity is 3 feet above the ground.

61. What do you understand by the principle of conservation of momentum? Shew how this principle is based on the laws of momentum.

A railway truck, weighing 10 tons, moving with a velocity of 4 miles per hour, impinges on another truck, weighing 8 tons, and moving in the opposite direction with a velocity of 1 mile per hour. When impact occurs the two trucks are automatically coupled together. Find the velocity of the trucks after impact, and the number of foot-tons of energy lost.

62. A cage is being pulled up a shaft with a velocity of 10 feet per second. A block of stone, weighing 50 lbs., is dropped down the shaft and after falling through 60 feet it meets the cage. The cage continues to ascend without change of velocity, carrying the stone with it. What is the impulse of the blow between the stone and the cage?

If the motion of the stone is completely reversed in half a second, what is the average value of the thrust between the cage and the stone?

63. On a railway line there are two points of observation 1 mile apart. A train passes the first point at 30 miles an hour, and after an interval of 90 seconds it passes the second point at the same speed. What is its average speed between the points? If the train had uniform acceleration during the first half of the interval and uniform retardation during the second half, what was the highest speed reached during the interval, and what was the value of the acceleration?

64. Simultaneous values of speed and time for a train are given in the table below.

Find graphically the acceleration in feet per second per second at the end of the 1st minute and at the end of the 5th minute.

Find also the distance passed over in attaining a speed of 55 miles per hour.

Time secs.	0	50	100	150	200	250	300	350	400	450	500
Velocity m. p. h.	0	24.6	36.3	43.7	48.3	51.3	53.5	55.1	56.2	57.6	57.9

65. In a steam engine mechanism, AB represents the crank, BC the connecting rod, and T is the point of intersection of the connecting rod and the line through A perpendicular to line of stroke. Shew that if M is the couple on the crank, the thrust on the crosshead in the direction of motion is given by $\frac{M}{AT}$, and the normal thrust on the guides of the crosshead is given by $\frac{M}{AC}$.

Shew, also, that the angular velocity ratio of the connecting rod and crank is equal to $\frac{BT}{BC}$.

66. An electrically propelled car is fitted with a recording accelerometer, the drum of which is driven by gearing connected to the wheels. The record traced in starting the car from rest is shewn in fig. 134. Find the velocity of the car after 5 seconds and the horse-power per ton which is then being expended in acceleration.

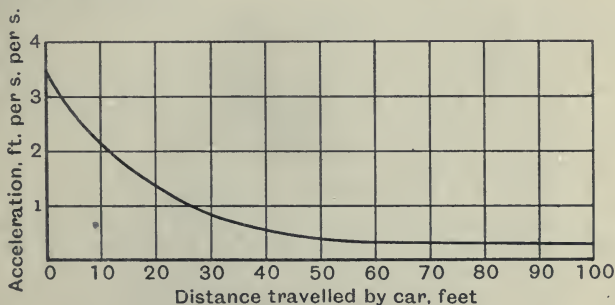

Fig. 134.

67. If a train's resistance to motion under certain conditions be $4 + \frac{V^2}{200}$ lbs. per ton, when the speed is V miles per hour, shew that the horse-power expended in hauling a train of 200 tons is $2.13V + 0.0026V^3$. Plot a curve shewing the relation between horse-power and speed between 10 and 40 miles per hour.

68. A truck moving with a given velocity impinges on another truck of the same mass which is at rest. Shew that, if there is no loss of energy due to the impact, the first truck will be left at rest, and the second truck will move off with the velocity originally possessed by the first truck.

69. Shew how the distance passed over in a given time by a body whose velocity continually varies with the time, may be estimated.

A body starts from rest with a constant acceleration of 1 foot per second per second; after a time the body has a constant retardation and finally comes to rest 10 miles from its starting point. Find the maximum velocity and the value of the retardation if the total time taken is 16 minutes.

70. A cage weighing 4000 lbs. is wound up a shaft. The relation between the tension, T lbs. wt. in the rope, and the distance, x feet, which the cage has risen, is given in the following table:

x	0	10	20	30	40	50	60	70	80
T	6000	5900	5660	5200	4500	3500	2650	2130	2000

Plot a curve for tension and distance, and find the work done during the 80 feet given, and the kinetic energy of the cage at the end of that distance.

At what point is the kinetic energy greatest, and what is then its value?

71. A door l feet wide, of mass m lbs., swinging to with an angular velocity ω radians per second is brought to rest in an angle θ radians by a buffer stop which applies a uniform force P at a distance $\frac{l}{6}$ from the axis of the hinges.

Find the magnitude of P , and the hinge reactions normal to the door, when the buffer is placed in a horizontal plane half way up.

72. A motor-car has 30 inch wheels, and weighs 2000 lbs. When travelling at 18 miles per hour, a total braking force of 500 lbs. is applied at a radius of 6 inches from the centre of the wheels.

Determine the time taken to reduce the speed to 10 miles per hour, and the ratio between the distances travelled while the speed was being reduced

from 18 to 10 miles per hour, and from 10 miles per hour till the car stopped. In practice, what other factors would have to be considered in making these calculations?

73. A 4 inch shaft is to be turned in a lathe. If the cutting speed is not to exceed 40 feet per minute what is the maximum speed at which the shaft may be rotated. The speed of the tool along the shaft is so small that it may be neglected.

74. The stroke of a steam engine is 24 inches, the cylinder diameter is 14 inches. Steam is admitted to the cylinder at 100 lbs. per sq. in. pressure, during a quarter of the stroke, and then expands, the expansion curve being the hyperbola $pv = \text{constant}$. On the other side of the piston there is a constant pressure of 16 lbs. per sq. inch. Plot a curve shewing the effective steam thrust on the piston during the stroke, and find how much work is done by the steam on the piston in one stroke.

75. A string 15 feet long has its ends fixed to two points at the same level and 10 feet apart. A smooth ring is threaded on the string and is initially held vertically below one fixed end of the string by a horizontal force. If the ring is suddenly released shew that it will move in an elliptical path. Find its velocity when it has travelled a horizontal distance (1) of 2.5 feet, (2) of 5 feet.

76. A flywheel weighing 10,000 lbs. is suspended from a pair of centres entering conical holes in the rim, so that it can swing in a vertical plane. The line joining the centres is parallel to, and distant 3 feet from, the axis of the wheel. The period of a complete swing is 2.5 seconds. Find the radius of gyration of the wheel, and the energy stored in it, when running at 250 revolutions per minute.

77. Two vessels start from the same point: one steams due north at 10 miles per hour, the other steams north-east at such a speed as always to keep due east of the first. Find the velocity of the second vessel, and the magnitude and direction of the relative velocity of the two.

At one hour from the start both vessels change their course and steam due west, maintaining the same speeds as before. After what time will the faster vessel overtake the slower, and how far has each steamed in the time?

78. The crank of a petrol engine is 3 inches and the connecting rod 12 inches long. The engine runs at 720 revolutions per minute. Find graphically the velocity of the piston when it has performed (a) one-quarter of its out-stroke, (b) one-quarter of its in-stroke.

Find also the angular velocity of the connecting rod for each of the two positions.

79. A pendulum bob, weighing 8 ounces, rotates uniformly in a horizontal circle at the end of a light string 1 foot long, the other end of the string being fixed. If it make 120 revolutions per minute, what is the tension in the string, and what angle does the string make with the vertical?

At what angle and with what speed does the pendulum rotate if the tension in the string is equal to four times the weight of the bob?

80. A lifting tackle consists of two blocks: the upper one is fixed and contains two sheaves, the lower one contains one sheave and is fast to one end of the rope. Sketch the tackle and find its velocity ratio.

The following table gives the pull required to lift various loads:

Load in lbs.	28	56	112	168	224	280	336
Pull in lbs.	30	38	64	87	109	130	150

Find the efficiency of the tackle for each of the given loads, and draw graphs of pull and efficiency on a load base.

81. A hose is directed perpendicularly against a wall and delivers 10 cubic feet of water per minute through a nozzle of 1 inch diameter, the water having no rebound from the wall. Determine the pressure on the wall.

82. A practical formula used for estimating the tractive force F , at the rails in lbs. for a two cylinder locomotive is, $F = \frac{PLD^2}{W}$, where W is the diameter of the driving wheels in inches, P is the mean pressure of steam in the cylinders in lbs. per sq. inch, D is the diameter of the cylinders in inches, and L is the length of stroke in inches. Derive this formula.

83. A jet of water impinges with velocity v feet per second on a series of plane vanes set round the circumference of a wheel and moving with velocity u feet per second. Shew that for each square inch of section of the jet the horse-power communicated to the wheel is very nearly $2.45(v-u)v \cdot u \cdot 10^{-5}$, and find an expression for the efficiency of the jet.

84. The slide-valve of a horizontal steam engine derives its motion from a point P in a link AB , where $AP = \frac{1}{3} AB$. The horizontal displacements of A and B for any crank position are given by the equations

$$x_1 = 2.5 \sin(\theta + 27^\circ),$$

$$x_2 = 2.6 \sin(\theta + 150^\circ).$$

Shew that the resulting motion of the valve may be expressed by the equation

$$x = a \sin(\theta + \epsilon)$$

and find the values of a and ϵ .

85. A flywheel possesses 50 foot-tons of kinetic energy when rotating at 200 revolutions per minute. What is its moment of inertia, the unit being 1 lb. at 1 foot radius? How many foot-lbs. of work must be done to increase its speed from 200 to 202 revolutions per minute?

86. A steam engine has a crank 9 inches long and a connecting rod 36 inches long. At the instant when the crank is at right angles to the connecting rod there is a thrust of 600 lbs. wt. in the piston rod. Find the turning moment on the crank, and the force on the crosshead guides.

On the return stroke there is a pull of 600 lbs. wt. in the piston rod at the instant when the crank makes 180° with the position given above. Find in this position the turning moment, and the force on the guides.

87. Three masses A, B, and C are bolted to the spokes of a horizontal wheel, the centre of which is O. The masses are 3, 5, and 4 lbs. respectively; $\hat{A}OB = 60^\circ$, $\hat{BOC} = 90^\circ$; $OA = 24$ inches, $OB = 20$ inches, $OC = 18$ inches. Find the magnitude and angular position of a mass D which will produce no resultant transverse thrust on the shaft, taking $OD = 15$ inches.

88. The speed and power trials of a cruiser gave the following results:

Speed in knots	14	18	22	26
Horse-power	2600	6000	11,300	23,000

Find the value of the resistance overcome at each speed, and plot curves of horse-power and resistance relative to speed.

If the vessel weigh 5000 tons, what additional horse-power is required to give the vessel an acceleration of 1 knot per minute when the speed is 22 knots? Take a knot as 100 feet per minute.

89. A flywheel and shaft, the moment of inertia of which is 10 lbs. ft.², are mounted on ball bearings so that friction may be neglected. The diameter of the shaft is 2 inches, and a string wrapped round it carries a weight of 10 lbs. The shaft is horizontal, and the string is so connected to it that, when completely unwound by the rotation of the shaft, it winds on again. The weight is supported 4 feet from the ground, with the string just taut, and is then let go. Find how high the weight will be raised after its first contact with the ground.

90. The mechanism of a small machine for punching holes in paper is shewn in fig. 135, the links being connected by pin joints, and the punch constrained to move vertically. Find, graphically, the velocity ratio of the points C and B.

Estimate the vertical force required at C to produce a force on the punch of 50 lbs. (a) when ABC is in the position shewn, (b) when ABC is perpendicular to OA.

OA = 1", AB = $\frac{5}{8}$ ", AC = $3\frac{1}{2}$ ", and O is $\frac{5}{8}$ " from the axis of the punch.

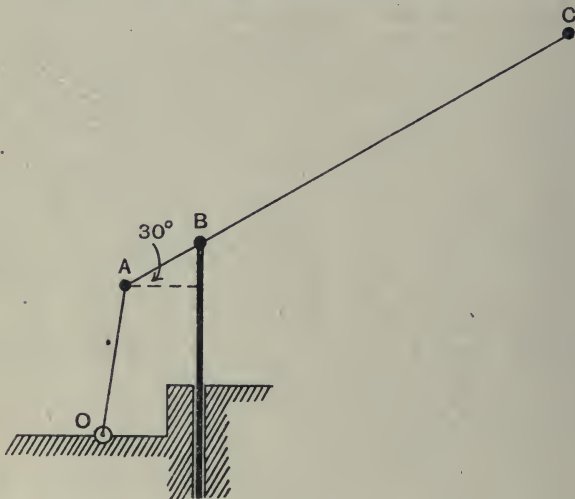

Fig. 135.

91. Two equal toothed wheels A and B are connected by a light link C. The wheels are rotating with an angular velocity ω , with the link C fixed, when suddenly the link C is released and the wheel A is fixed. Shew that, if the inertia of the link be neglected, it will begin to rotate with an angular velocity $\frac{k^2 \omega}{2(k^2 + a^2)}$, where k is the radius of gyration of either wheel about its centre, and a is the effective radius of the wheels.

What is the impulsive couple which will be required on wheel A?

92. A pendulum consists of a thin rod weighing 2 ounces and a uniform disc of 3 inches diameter weighing $\frac{1}{2}$ lb. The rod which is 3 feet long extends to the centre of the disc. Find the periodic time of swing of the pendulum when suspended from the free end.

93. It is required to transmit 25 horse-power from a pulley of 30 inches diameter running at 350 revolutions per minute, by means of a belt. Find the required width of the belt, having given the ratios of the tensions on the two sides to be equal to 2, the thickness $\frac{3}{8}$ inch, and the allowable stress 500 lbs. per sq. inch.

94. A smooth wire, bent into the form of a circle of radius r , is rotating above its vertical diameter with angular velocity ω . If a mass is strung on the wire, shew that it will be in equilibrium when its angular distance, θ , from the vertical diameter is such that

$$r\omega^2 \cos \theta = g.$$

The mass is given a small displacement from its position of equilibrium, shew that it will oscillate about this position and that the period of oscillation is

$$\frac{2\pi}{\omega \sin \theta}.$$

95. For the purpose of conveying small packages from one room to another vertically above it, the package is enclosed in a small cylinder which forms a piston for a vertical tube passing from the one room to the other. The cylinder being fitted into the lower end, the upper portion of the tube is connected to a reservoir in which a vacuum of 5 lbs. per sq. inch by gauge is maintained. The cylinder and contents weigh 1 lb. and the diameter is $1\frac{1}{2}$ inches. Taking the friction between the tube and the cylinder to be 1 lb. find the time for the cylinder to travel vertically upwards 40 feet from the starting point, and also find the velocity of arrival. The vacuum pressure may be assumed to remain constant, and the effect of the inertia of the air below the cylinder may be neglected.

96. A mass m , whose centre of gravity is at a point B, is supported by two equal links AB, CB, which are hinged to a vertical spindle at A and C. Find the forces in the links AB, CB

(1) when the system is at rest;

(2) when it is rotating about AC with angular velocity ω and $\omega^2 = \frac{2g}{AC}$;

(3) when it is rotating about AC with angular velocity ω and $\omega^2 = \frac{4g}{AC}$.

97. A steam engine is suddenly brought up by an unyielding obstacle interposed in the line of motion of the piston rod; find the impulse for a given position of the crank, taking into account the momentum of a flywheel on the crank shaft, and of a piston and connecting rod, but neglecting the angular motion of the connecting rod, that is to say treating it as of infinite length.

98. The displacement s , in feet, of a piston is given in terms of the time t , in seconds by

$$s = 0.5 \cos 4\pi t + 0.25 \cos 8\pi t.$$

If the piston weighs 20 lbs. find the force in the piston rod required for accelerating at the following times, 0 , $\frac{1}{10}$, $\frac{1}{8}$, $\frac{1}{4}$ second.

Find also the kinetic energy given out or taken in by the piston (1) during the first half-stroke, (2) during the middle half-stroke.

99. A particle is suspended by three equal strings of length a from three points forming an equilateral triangle of side $2b$ in a horizontal plane. If one string be cut, shew that the tension of each of the others is instantaneously changed in the ratio

$$\frac{3a^2 - 4b^2}{2(a^2 - b^2)}.$$

100. A wheel of 24 inches diameter, and having a radius of gyration of 10 inches, rolls along the ground and meets a step 6 inches high. Shew that if the speed of the wheel is less than 6.18 feet per second it will not be able to lift itself on to the step. Assume that the wheel is inelastic, and that there is no slipping at its point of contact with the square edge of the step.

ANSWERS TO EXAMPLES

CHAPTER I. (PAGES 17—19)

- 1.** 554 yards; $15^\circ 45'$ west of north; 533 yards; 150 yards.
2. 1.732; 1.5; 0.866. **3.** 331 lbs.; $73^\circ 34'$ north of east.
4. (a) 2.1, $106\frac{1}{2}^\circ$; (b) 5.06, 329.4° ; (c) 7.97, 118° . **5.** 6.1 feet.
6. 60; 66. **7.** 2340; 390. **8.** 37,600; 76,800; 3600; 1300.
9. $\frac{\pi}{3}$; $-\frac{\pi}{\sqrt{3}}$. **10.** ∓ 1.13 ; ± 1.13 . **11.** 2.15 square inches.

CHAPTER II. (PAGES 51—56)

- 1.** (1) 8.97 metres per second. (2) 26.84 metres per second.
 (3) 27.96 metres per second.
2. 1056 feet per second. **3.** 47.3 feet.
6. 131 feet per second; 150 feet per second; zero.
7. 34.4 feet per second; 10.47 radians per second; 420 revolutions per minute.
8. 4400 feet per minute; 840 revolutions per minute; 88 radians per second.
9. 3000 revolutions per second. **10.** 2.62 feet per second.
13. 1.05 miles; 22.8 miles per hour; 1.65 feet per second per second; 0.42 foot per second per second; 2.08 feet per second per second.
14. $\alpha = 261.8 \cos 25t + 43.5 \cos 50t$. **18.** 21.2 feet.
19. 2055 feet per second; 411 feet per second. **20.** $51^\circ 20'$; 88° .
21. 3.88 feet per second; $52^\circ 12'$ north of east; 0.554 foot per second per second.
22. 66.7 feet per second per second.
23. 12.2 minutes; 151° to the direction of current;
 7.1 ,, 123° ,, ,,
24. 44 seconds; 2499 feet. **25.** 23.2 knots; 4.12 hours; 7.07 sea miles.
26. 35 miles per hour; inclined at 82° to OB.
27. Greater for $\theta = 45^\circ$.
28. 200 revolutions per minute; 127 feet per second inclined at 150° and 30° with the direction of motion of the train.
29. 0.655 foot per second; 1.635 feet per second. **30.** 10 seconds; 50 feet.
31. 6.72 inches; 0.69 second; 0.81 second; 80 feet per minute; 63.2 feet per minute.
32. 324 feet per minute.

CHAPTER III. (PAGES 83—87)

1. 222 lbs. wt.; $\frac{5}{7}$ foot per second per second; 510 feet.
2. 72,100 poundals; 10^{10} dynes.
3. 1·305 tons wt.
5. 2000 lbs. wt.; 2125 lbs. wt.; 1688 lbs. wt.
6. 1674 lbs. wt.; 3·86 feet per second per second.
7. 11·4 seconds; 167 feet; 13·1 seconds; 192 feet.
8. 0·354 lb. wt. inclined at 45° to the original direction of motion.
9. 98 lbs. wt.; 170 lbs. wt.
10. 1·77 feet per second.
12. 116 lbs. wt.
13. 92 seconds.
14. $\frac{1}{2}$ ton wt.
15. 550 lbs. wt.; 505 lbs. wt.
16. 138·6 seconds; 10,000 feet.
17. 1·06 feet per second per second upwards.
18. 1700 feet per second; 750 lbs. wt.
19. 96 square feet.
20. 4·97 lbs. wt.
21. 0·0122 second; 2·73 feet per second.
22. 1·14 feet per second per second.
23. 35, 21·2, -5, -21·2, -25 tons wt.
25. 6·6 inches.
26. 0·517 tons. 12·85 tons-feet-seconds units.
27. 950 lbs. wt.
28. 1·19 seconds; 286,000 absolute c.g.s. units; 18·1 centimetres.
29. 46 absolute f.p.s. units; 3·83 feet per second.
30. (A) 13 feet per second; 9 feet per second. (B) 7 feet per second; 11 feet per second.

CHAPTER IV. (PAGES 107—109)

1. 14·7 lbs. feet.
2. 0·025 feet per second per second; 14·45 revolutions.
3. $\frac{\{4(M+m)+W\}M}{4M+2m+W}g$; $\frac{(4M+W)(M+m)}{4M+2m+W}g$; $\frac{8M^2+8Mm+W(2M+m)}{4M+2m+W}g$.
4. 32 feet per second; 128 radians per second; 26·9 lbs. feet².
5. 0·155g foot per second per second.
6. 12 lbs. feet; 7·4 lbs. feet; 720 revolutions.
7. 40·03 lbs. feet.
9. 0·186 lbs. feet.
10. 50 absolute f.p.s. units; 0·032 absolute f.p.s. units.
11. 8660 lbs. feet².
15. 1 foot 3 inches from the hinge.
16. 318 lbs. feet.
17. 20 revolutions per minute.
18. 83·3 lbs. feet².
19. 2·65 lbs. feet².
20. 3360 lbs. feet².
21. (1) 6·53 lbs. feet². (2) 298 lbs. feet².

CHAPTER V. (PAGES 124—127)

1. 36.8 revolutions per minute. 2. $\left\{l^2 - \frac{8350g^2}{n^4}\right\}^{\frac{1}{2}}$; 3.58 feet.
3. Pull of 12.5 lbs. wt. at A and push of 12.5 lbs. wt. at B.
 „ 26.8 „ „ pull of 1.7 „
 92.3 revolutions per minute.
4. 10.36 miles per hour inclined at 75° to the road.
 20 „ „ „ 150° „
 38.6 „ „ „ 165° „
5. 7.7 lbs.; 0.4 lbs. wt. 6. 6.2° ; $6\frac{1}{2}$ inches.
7. 847 lbs. wt.; 24.4 miles per hour. 8. 25.8° ; 767 lbs. wt. per ton.
9. 1182 lbs. wt.
10. 270 revolutions per minute; 266 revolutions per minute.
11. 473 revolutions per minute. 12. 50.4 tons wt.; $9\frac{1}{2}$ inches; 63 tons wt.
14. 5.23 tons wt. 15. 4.54 tons wt. 2.8 inches. 16. 2.83 inches.

CHAPTER VI. (PAGES 154—161)

1. 6800 ft.-tons; 60.8 horse-power; 31.7 horse-power.
2. 346 ft.-tons; 1970 strokes; 471 lbs. wt.
3. 40 lbs. per square inch; 8200 foot-lbs. 4. 169 feet; 1.07 horse-power.
6. 0.62 horse-power; 60 feet per minute; 120 feet per minute; 1.65 horse-power.
7. 12.1 ft.-tons; 0.269 ton wt.
8. 6.3 feet per second; 538 feet. 9. 8.75 horse-power; 47.5 miles per hour.
10. 6.6 inches. 11. 16.7 miles per hour; 9.32 ft.-tons.
12. 9.6 ft.-tons; 3.3 ft.-tons; 5.2 horse-power.
13. 17 feet per second; 2.25 tons wt.; 2.52 tons wt.
14. 1880 feet per second. 15. 12.5 lbs. per ton; 333 horse-power.
- 16.

Distance feet	0	10	20	30	40	50
Speed feet per second	0	6	8	9.2	9.9	10.3

13.4 ft.-tons.

17. 5.06 feet per second; 33.6° . 18. 3.26 feet per second.
19. 2.45 inches. 20. 99.75 per cent., 3125 lbs. wt.
21. 9.8 inches; 5.15 feet per second.
22. 41.7 tons wt.; 1785 horse-power.
23. 5867 abs. ft.-ton-sec. units; 13,400 ft.-tons; 293 feet; 45.8 tons wt.

- 24.** 0.294 foot per second per second; 0.22 foot per second per second.
25. 18.9 horse-power. **26.** 1.33 horse-power; 0.43 horse-power.
27. 4 radians per second; 1250 lbs. wt.; 3.98 radians per second.
28. 3300 ft.-lbs.; 289 ft.-tons; 3.76 seconds.
29. 8160 lbs. ft.; $1\frac{1}{2}$ per cent. **30.** 105.5 ft.-tons; 57.5 per cent.
31. A, 56.5 revolutions per minute; B, 443.5 revolutions per minute;
 0.155 second; 326 lbs. wt. sec. units.

CHAPTER VIII. (PAGES 183—186)

- 2.** 2.09 seconds; $\frac{9}{16}$ lb. wt. **3.** 4.32 seconds.
4. 6π feet per second; 665 lbs. wt.; 337.5 lbs. wt.; 1.65 seconds.
7. 2.048 feet per second; 2.052 feet per second. **8.** 1.57 seconds.
10. 31 ft.-tons. **11.** 0.179 second; 1.3 inches; 3 feet per second.
12. 1.4 seconds. **13.** 30.4 seconds. **14.** 224 lbs. wt.
17. 1.57 seconds; 1.59 seconds. **18.** 12.3 tons wt.

CHAPTER IX. (PAGES 210—218)

- 1.** $9\frac{3}{8}$ inches. **2.** 0.57 horse-power.
3. 0.28 horse-power-hour; 44.2 lbs. wt. **4.** 5.07 horse-power.
5. 39.4 feet per minute; 8.38 lbs. feet. **6.** 61.5 per cent.; $3\frac{1}{4}$ tons; $\frac{3}{4}$ ton.
7. 0.215; 0.45 ton wt. **8.** (1) 57 lbs. wt. (2) 203 lbs. wt.
9. 23.6 horse-power; 1.4 horse-power; 722.5 lbs. wt.; 147 lbs. wt.
10. $P = 18.4W + 12.6$, where P = the effort in lbs., and W = the load in tons.
11. 2533 lbs. feet; 1733 lbs. feet; 328 lbs. feet.
12. 221 revolutions per minute; 30.2 horse-power. **13.** 41.1 horse-power.
14. 0.547 foot per second; 136.5 absolute F.P.S. units; 33.6 ft.-lbs.
15. 6.55 tons wt.; 673 tons.
16. 35.5 lbs. per square inch; 190 ft.-tons; 12.9 horse-power.
17. 13.7 tons wt.; 17 knots. **18.** 21.8 ft.-tons; 106 revolutions per minute.
19. 18.5 horse-power; 3.3 horse-power. **20.** 86 per cent.
21. 85.5 lbs. feet; 301 lbs. feet; 258 lbs. wt.; 30.2 miles per hour.
22. 14.5 revolutions. **23.** 1.82 horse-power; 37.8 per cent.
24. 318 revolutions per minute; 0.74 horse-power.
25. 100 per cent. (nearly); 75.6 per cent. **26.** 9.6 horse-power.
27. 1.25 feet per second per second.
28. (1) $g \sin a$. (2) $\frac{9}{10}g \sin a$. (3) $\frac{13}{16}g \sin a$.
29. 48.5 per cent.; 55 per cent.; 31.6 horse-power.
30. 111 ft.-lbs.; 37 ft.-lbs.; 74 ft.-lbs.

INDEX

(The numbers refer to the pages)

- | | |
|--|---|
| <p>Absolute unit of force 59
 Absorption brake 188
 Accelerating force on piston 67
 Acceleration 29
 Acceleration due to gravity 39
 " " to change of direction 43
 Action and reaction 79
 Amplitude 168
 Angular momentum Chapter IV 88
 " velocity 27
 Area curve 15
 Average value 9
 " velocity 21

 Ballistic Pendulum 143
 Belts 187
 Brake, absorption 188

 Cant on railway curves 119
 Centre of gravity 117
 " " mass or inertia 115
 Centrifugal force Chapter V 110
 Centripetal force 110
 C.G.S. Units 2
 Circular motion 43
 Components 7
 Conical pendulum 111
 Conservation of momentum 55, 147
 " " energy 55, 136, 147

 Density 3
 Dimensions 162
 Dyne 60

 Efficiency 191
 Energy Chapter VI 131
 " " potential and kinetic 132
 " " conservation of 136
 Equilibrium 78</p> | <p>Erg 129
 Examples Chapter I 17
 " " II 51
 " " III 83
 " " IV 107
 " " V 124
 " " VI 154
 " " VIII 183
 " " IX 210
 " Miscellaneous 219

 Force 58
 " " Unit of 59, 60
 Forces—external and internal 89
 F.P.S. Units 2

 Gearing 194
 Gravitation unit of force 60
 Gravity—Acceleration due to 39

 Harmonic motion 166
 " " and circular motion 177
 Horse-power 130
 Horse-power-hour 131

 Impact 78
 Impulse 76
 Impulsive force—magnitude of 77
 Impulsive torque 92
 Indicated horse-power 197
 Inertia 90

 Joule 130

 Kinematics 1
 Kinetics 1
 Kinetic energy 132
 " " due to rotation 147
 " " total 206</p> |
|--|---|

- Laws of momentum 58
 „ „ motion Preface vi
 Length 2
 Linear momentum Chapter III 57
 „ velocity 20
 „ acceleration 29
 Mass 2
 Machines Chapter IX 189
 Mechanical Advantage 19
 Mechanics 1
 Momentum, Linear Chapter III 57
 „ „ Angular „ IV 88
 „ „ Laws of 58
 Moment of a force 89
 „ „ inertia, definition 90,
 values of 101
 Motion Chapter II 20
 „ „ Third Law of 79
 Newton—Laws of Motion Preface vi
 Oscillation 170
 Pelton Wheel 203
 Pendulum, Simple 170
 „ „ Compound 172
 „ „ Simple Equivalent, 173
 Periodic time 168
 Piston-velocity 49
 „ accelerating force 67
 Potential Energy 132
 Poundal 60
 Power Chapter VI 130
 „ „ Unit of 130
 Projectiles 39
 Radius of gyration 105
 Railway curves 119
 Rate of change 10
 Relative momentum 195
 „ kinetic energy 195
 „ velocity 45
 Resultant 6
 Retardation 33
 Rolling Wheel 50
 Routh's Rule 101
 Scalar quantity 3
 Simple equivalent pendulum 173
 Simple harmonic motion 166
 Space 2
 Space-average of force 129
 Specific gravity 3
 Speed 20
 Springs 139, 149, 169
 Statics 1
 Steam tractor—Mechanical losses
 200
 Stress 78
 „ in flywheel 122
 Subnormal 32
 Third law of motion 79
 Time 3
 Time-average of force 129
 Torque 89
 Transmission of power by belts 187
 Units, C.G.S. and F.P.S. 2
 Units and dimensions Chapter VII
 162
 Varying Force 66
 „ Torque 91
 Vectors 3
 Velocity, linear 20
 „ „ angular 27
 „ „ curves 22
 „ „ average—instantaneous 21
 „ „ relative 45
 Velocity-ratio 189
 Vibration 167
 Watt 130
 Weight 60
 Work Chapter VI 128
 „ „ Unit of 129

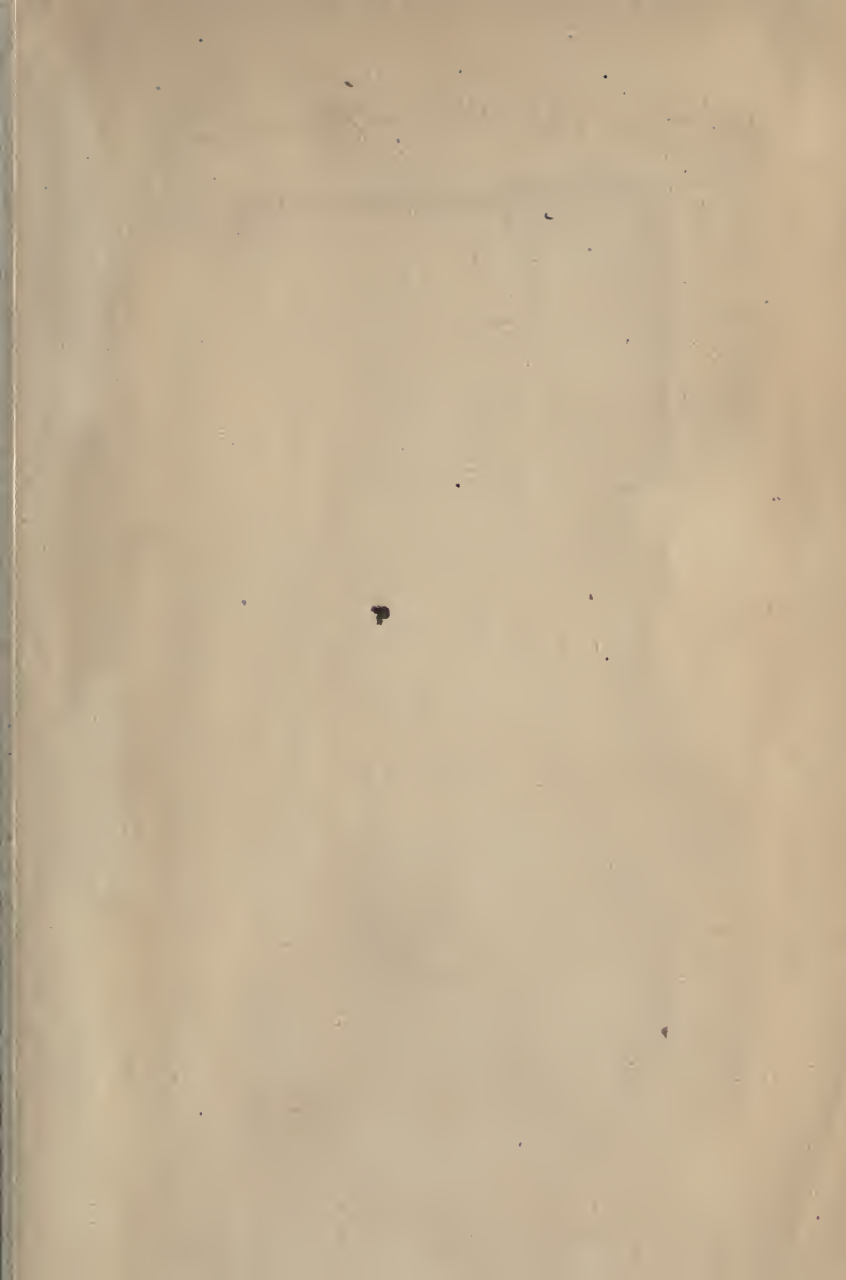

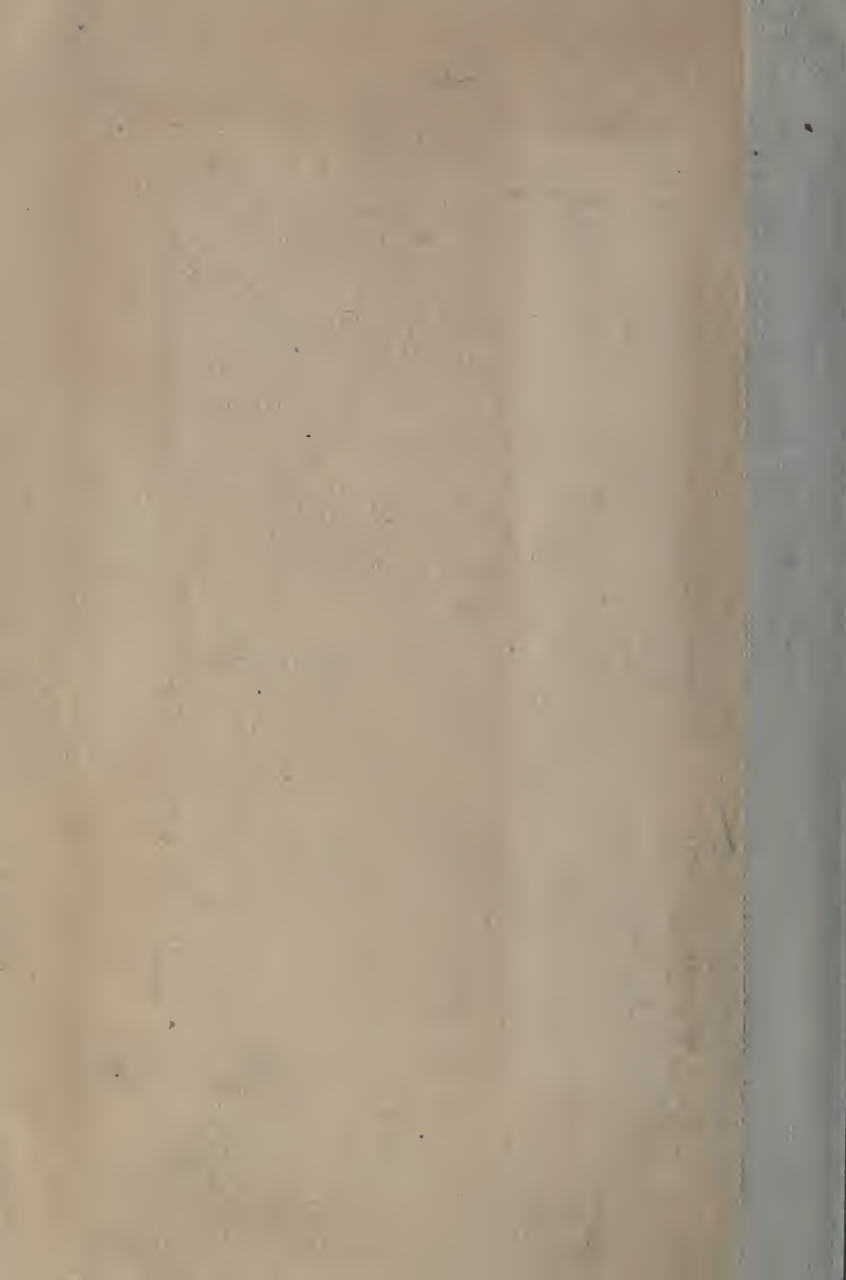

176512
Landon, Joseph Whittington
Elementary dynamics.

Physics
Mech
L

**University of Toronto
Library**

**DO NOT
REMOVE
THE
CARD
FROM
THIS
POCKET**

Shapettin

Acme Library Card Pocket
LOWE-MARTIN CO. LIMITED

