

Solomon I. Khmelnik

Variational Principle of  
Extremum in  
electromechanical and  
electrodynamic Systems

First Edition, 2008  
Second Edition, 2010  
Third Edition, 2012  
Fourth Edition, 2014

Israel 2008

**Copyright © 2004 by Solomon I. Khmelnik**

All right reserved. No portion of this book may be reproduced or transmitted in any form or by any means, electronic or mechanical, without written permission of the author.

Published by “MiC” - Mathematics in Computer Comp.

POB 15302, Bene-Ayish, Israel, 60860

Fax: ++972-8-8691348

Email: [solik@netvision.net.il](mailto:solik@netvision.net.il)

Printed in United States of America, Lulu Inc., ID 1142842

**ISBN 978-0-557-08231-5**

# Annotation

Here we shall formulate and prove the variational optimum principle for electromechanical systems of arbitrary configuration, in which electromagnetic, mechanical, thermal, hydraulic or other processes are going on. The principle is generalized for systems described by partial differential equations, including also Maxwell equations. The presented principle permits to expand the Lagrange formalism and extend the new formalism on dissipative systems. It is shown that for such systems there exists a pair of functionals with a global saddle point. A high-speed universal algorithm for such systems calculation with any perturbations is described. This algorithm realizes a simultaneous global saddle point search on two functionals. The algorithms for solving specific mathematical and technical problems are cited. The book contains numerous examples, including those presented as M-functions of the MATLAB system and as functions of the DERIVE system. The programs in systems MATLAB and DERIVE are published as a separate annex in the form of an electronic book [52]. Programs are not required to understand the theory.

# Contents

|  |     |
|--|-----|
| Detailed Contents \  | 5   |
| Preface \  | 11  |
| Chapter 1. RCL-circuits with Electric Charges \                  | 16  |
| Chapter 2. RCL-circuits with Electric Currents \                 | 32  |
| Chapter 3. Special Transformers in Alternating Current Circuits\ | 42  |
| Chapter 4. Generalized Functional \                              | 55  |
| Chapter 5. Electric Circuit Computing Algorithms \               | 62  |
| Chapter 6. Variational Principle and Maximum Principle \         | 99  |
| Chapter 7. Electromechanical Systems \                           | 140 |
| Chapter 8. The Functional for Partial Differential Equations \   | 151 |
| Chapter 9. The Functional for Maxwell Equations \                | 185 |
| Chapter 10. Principle extremum of full action \                  | 329 |
| References \   | 339 |
| Main Notations \   | 344 |
| Some of the Terms \  | 347 |

---

# Detailed contents

**Preface \ 11****Chapter 1. RCL-circuits with Electric Charges \ 16**

0. Introduction \ 16
1. Series RCL-circuit \ 20
2. The Computing Algorithm for RCL-circuit \ 22
3. The Equations for General-Form Electric Circuit \ 24
4. The Functional for General-Form Electric Circuit \ 26
5. The Computing Algorithm for General-Form Electric Circuit \ 27
  - Special Case 1. Circuit with One Node \ 29
  - Special Case 2. Circuit with One Branch \ 29
  - Special Case 3. Circuit with One Branch and One Current Source \ 30
6. The Properties of Mutual Inductances Matrix \ 30

**Chapter 2. RCL-circuits with Electric Currents \ 32**

1. The Functionals of Integral Functions \ 32
2. The Integral Equations of RCL-circuit \ 33
3. The Computing Algorithm for Integral Equations of RCL-circuit \ 34
4. Integral Equations of General-form Electric Circuit \ 37
5. Functional for Integral Equations of General-form Electric Circuit \ 37
6. Computing Algorithm for General-Form Electric Circuit Integral Equations \ 38
  - Special Case 1. Circuit with One Node \ 40
  - Special Case 2. Circuit with One Branch \ 40
  - Special Case 3. Circuit with One Branch and One Current Source \ 41

**Chapter 3. Special Transformers in Alternating Current Circuits \ 42**

1. Electric Circuit with Dennis Transformers \ 42
2. Unconditional Electric Circuit with Dennis Transformers \ 50
3. Electric Circuit with Integrating Transformers \ 51

**Chapter 4. Generalized Functional \ 55**

1. Generalized Functional for Unconditional Electric Circuit \ 55
2. Sufficient Conditions of Existence for Generalized Functional's Extremum \ 59
3. Generalized Functional for General-form Electric Circuit \ 61

**Chapter 5. Electric Circuits Computing Algorithms \ 62**

1. General Algorithm \ 62
2. System of Linear Differential Equations \ 63
  1. Method 1 \ 63
  2. Method 2 \ 65
3. Interoperable Functions \ 66
4. Sinusoidal Functions \ 68
5. System of linear Algebraic Equations \ 70
  1. Method 1 \ 70
  2. Method 2 \ 75
  3. About Matrix Processor \ 77
6. Computing linear electric circuits with sinusoidal current \ 78
7. Trigonometric Series \ 85
8. Periodical Functions \ 85
9. Exponential Functions \ 85
10. The Functions Determined on the Positive Time Semiaxis \ 88
11. Step Functions \ 90
12. Displaced Step Function \ 96
13. Multistep Functions \ 97
14. An Exponential on the Positive Time Semiaxis \ 97
15. Trigonometric and Hyperbolic Series on the Positive Time Semiaxis \ 98

**Chapter 6. Variational Principle and Maximum Principle \ 99**

1. Introduction to Maximum Principle \ 99
2. Maximization Method \ 101
3. Second Order Differential Equations Systems with Step Excitations \ 105
4. First Order Differential Equations Systems with Step Excitations \ 110
5. Differential Equations Systems with Multi-step Excitations \ 119
6. First Order Differential Equations Systems with Excitations in the Form of Dirac Functions \ 121
  - 6a. Second Order Differential Equations Systems with Excitations in the Form of Dirac Functions \ 130
7. Maximization Algorithm for the Electrical Circuits Computation \ 132
8. Maximization Algorithms for Computing Electric Circuits with Switchings \ 136

---

**Chapter 7. Electromechanical Systems \ 140**

1. General Case \ 140
2. Example. Collector Machine \ 143
3. More about Electric Circuits \ 145

**Chapter 8. The Functional for Partial Differential Equations \ 151**

1. Variational Optimum Principle for Electric Lines and Planes \ 151
  1. The equations of continuous electric line \ 151
  2. The equations of discrete electric line \ 152
  3. The Functional for Continuous Electric Line \ 156
  4. The Functional for Continuous Electric Plane \ 163
2. An Electric Line for Poisson Equation Modeling \ 164
  1. Introduction \ 164
  2. The Equations of a Discrete Electric Line \ 166
  3. The Functional for Continuous Electric Line \ 171
  4. The Functional for Continuous Electric Volume \ 175
  5. The Functional for Non-Homogeneous Continuous Electric Volume \ 177
3. Partial Differential Equations \ 178
  1. Classical Partial Differential Equations \ 178
  2. Special Partial Differential Equations \ 183

**Chapter 9. The Functional for Maxwell Equations \ 185**

1. Maxwell Equations as a Corollary of Variational Principle \ 185
  1. Introduction \ 185
  2. Constructing a functional for the Maxwell Equations \ 189
  3. About Sufficient Extremum Conditions \ 192
  4. First Partial Derivatives \ 195
  5. Second Partial Derivatives \ 198
2. Computational Aspect \ 201
3. Nonlinear Maxwell Equations \ 205
4. Example. The Coaxial Cable Computation \ 206
  1. Setting up a problem \ 206
  2. Functional of the problem \ 208
  3. The Solution of the Problem with Fixed Functions of Time \ 210
  4. The Solution of the Problem with Fixed Functions of Variable  $z$  \ 213
  5. A Cable of Variable Diameter \ 215
5. Computational Aspect - continued \ 218

6. Example. Spatial Electromagnetic Wave \ 224
  1. Computation of numbers (9.5.2), (9.5.14) and matrices (9.5.3), (9.5.15) \ 224
  2. Setting of the Problem \ 228
  3. Computing the vectors (9.5.7, 9.5.9) \ 229
  4. Iterations \ 230
  5. Exponentially Distributed Charges Modeling \ 231
  6. Periodically Distributed Charges Modeling \ 234
  7. Modeling with Charges Distributed According to Dirac Function \ 235
    - 7a. Magnetic wave in simulation with charges distributed according to Dirac function \ 241
    - 7b. Electric wave in simulation with charges distributed according to Dirac function \ 242
  8. Modeling with Charges Distributed According to Step Function \ 243
  9. Modeling with Charges Distributed Non-uniformly \ 246
  10. Discussion \ 247
7. Example. Superpositions of Electromagnetic Waves \ 248
  1. Electromagnetic oscillations with exponentially distributed charges. Case 1. \ 248
  2. Electromagnetic oscillations with exponentially distributed charges. Case 2. \ 251
  3. Electromagnetic oscillations with linear movement of exponentially distributed charges \ 251
    - 3a. Electromagnetic oscillations at compound motion of the exponentially distributed charges \ 254
  4. Magnetic oscillations with charges distributed according to Dirac function. Case 1. \ 255
  5. Magnetic oscillations with charges distributed according to Dirac function. Case 2. \ 255
  6. Magnetic oscillations with linear movement of charges, distributed according to Dirac function \ 256
8. Example. Electromagnetic radiation of the localized charges \ 258
  1. Problem definition \ 258
  2. Computing vectors (9.5.7, 9.5.9) \ 259
  3. Computations \ 260
  4. Modeling of wave with electric and magnetic charges exponentially distributed along  $y$ ,  $z$  axes and with Dirac distribution along  $x$  axis \ 260



- 
- 4a. Modeling of wave with magnetic charges distributed periodically along the  $y, z$  axes and with Dirac distribution along  $x$  axis \ 262
  - 5. Modeling of wave with magnetic charges distributed exponentially along the axes  $y, z$  and with Dirac function distribution along  $x$  axis \ 263
  - 5a. Modeling of wave with magnetic charges periodically distributed along the axes  $y, z$  and with Dirac distribution along the  $x$  axis \ 264
  - 6. Modeling of wave with electric charges exponentially distributed along the axes  $y, z$  and with Dirac distribution along the  $x$  axis \ 276
  - 6a. Modeling of wave with electric charges distributed periodically along the axes  $y, z$  and with Dirac distribution along the  $x$  axis \ 271
  - 9. Analytical Method of Maxwell Equations Solution \ 272
    - 9. 1. Description of the method \ 272
    - 9. 2. Examples of Functions
      - Chp(w), Chd(w), Shp(w), Shd(w) \ 278**
    - 9. 3. Using the method for  $\Xi(x) = \lambda'(x)$  II
      - $k_{sp} = k_{sd} = k_{cp} = k_{cd} = 1$  \ 279
        - 9.3.1. The general solution \ 279
        - 9.3.2. Solution in the medium without scalar magnetic potential -  $\zeta = 0$  \ 287
          - 9.3.2.1. Magnetic charges in the medium without scalar magnetic potential \ 287
          - 9.3.2.2. Electrical charges in the medium without scalar magnetic potential \ 290
        - 9.3.3. Solution in vacuum \ 292
          - 9.3.3.1. Magnetic charges in vacuum \ 292
          - 9.3.3.2. Magnetic charges in vacuum \ 295
          - 9.3.3.3. Harmonic static magnetic field \ 295
          - 9.3.3.4. Harmonic static electric field \ 296
    - 9.4. Using the method for  $\Xi(x) = \lambda(x)$  and
      - $k_{sp} = k_{sd} = k_{cp} = k_{cd} = 1$  \ 296
        - 9.4.1. General solution \ 296
        - 9.4.2. Magnetic charges in vacuum \ 300

9.4.3. Electrical charges in vacuum \ 302

9.4a. Using the method for impulse function  $\Xi(x)$  and

$$k_{sp} = k_{sd} = k_{cp} = k_{cd} = 1 \ \backslash \ 303$$

9.5. Using the method for  $\Xi(x) = \lambda'(x)$  and

$$k_{sp} = k_{sd} = 1, \ k_{cp} = k_{cd} = -1 \ \backslash \ 307$$

9.6. Using the method for  $\Xi(x) = \lambda(x)$  and

$$k_{sp} = k_{sd} = 1, \ k_{cp} = k_{cd} = -1 \ \backslash \ 307$$

9.10. A summary of models from Sections 9.6, 9.7, 9.8. \ 308

9.11. The Maxwell Equations in Cylindrical Coordinates \ 314

9.11.1. The first variant \ 314

9.11.2. The second variant \ 317

9.12. Monochromatic Fields \ 319

9.13. The Static Electric and Magnetic Fields \ 322

1. The Electric Field of a Charged Infinite Strip \ 322

2. The Variational Principle for Plane Static Electric Fields \ 323

3. The Magnetic Field Around an Elongated End of a  
Permanent Magnet \ 325

4. The Magnetic Field of a Strip Conductor \ 325

5. Variational Principle for a Strip Conductor \ 326

6. Variational Principle for Three-dimensional Static Electric  
Fields \ 327

## **Chapter 10. Principle extremum of full action \ 329**

10.1. The Principle Formulation \ 319

10.2. Electrical Engineering \ 331

10.3. Mechanics \ 332

10.4. Electrodynamics \ 333

10.4.1. The power balance of electromagnetic field \ 333

10.4.2. Building the functional for Maxwell equations \ 335

10.4.3. Splitting the functional for Maxwell equations \ 337

10.5. Principle extremum of full action for hydrodynamics \ 338

10.6. Computational Aspect \ 338

## **References \ 339**

## **Main Notations \ 344**

## **Some of the Terms \ 347**

# Preface

---

The search for variational principles for the electromechanical systems of arbitrary structure and configuration is a subject of theoretical and practical interest. In this connection we shall consider below a problem of looking for such a functional whose steady-state equations are equations of electromechanical system. For mechanical systems such principles are generally known. For special cases of electric circuits the solution of this problem is known. For instance, for circuits with resistances the solution has been found by Maxwell [1], and was extended not long ago to circuits with diodes and direct-current transformers [2]. Another generalization for circuits with non-linear resistances may be found in [3, 4]. For circuits with capacitances and inductances (but without resistances) is also known [3, 5]. In [6] the works are listed in which attempts were made to solve the problem for general-form electric circuit, and all these attempts were proved insolvent. The reason for such search is understandable, as the absence of extremum principle for electric circuits seems to be rather strange. As regards to the practical side of the question, the existence of such principle permits to use alternate current electric circuits for calculus of variation problems simulation: these circuits are nature's own simple-device computer that solves a very complicated mathematical problem (using an algorithm of unknown kind).

On the other hand, a discussion in the terms of electric circuits may lead to the development of certain problems of calculus of variations. An example of a similar influence of the direct-current electric circuits theory on the theory of mathematical programming may be found in the work [2]. Lastly, the calculus of variations theory may also be used for electric circuits and electromechanical systems computing. Such approach has been used by the author. The extremum principle for alternating current electric circuit was formulated by the author in 1988 in [8] and was developed in the articles [9, 10, 15, 16]. The first edition of this book was published in [31].

The basic idea is that *the current function is "split" into two independent functions*. The proposed functional contains such pairs of functions; its optimum is a saddle point, where one group of functions minimizes the

functional, and the other one – maximizes it. The sum of the optimal values of these functions gives the current function of the electric circuit.

The previously presented results will be generalized and developed below; the computational aspect of this principle's use will be considered as well. Furthermore, this principle will be extended to electromechanical systems, since it may be integrated with a principle known in mechanics as the minimal action principle, since it is a generalization of a known principle of least action. For a given electromechanical system a functional containing functions of thermal, mechanical, electric and electromagnetic energies, as well as the functions describing the perturbation actions – electric and mechanical, is formed. These functions depend on the system's configuration. The functional has the dimension: "energy\*time". The functional is a quadratic function of the sought parameters, and it has a sole optimal point. There are no constraints (they are also included into the functional). The functions providing the optimal value of the functional present solution of the given electromechanical system's calculation problem. Consequently, the given electromechanical system's calculation may be stated mathematically as a variational problem of seeking *an unconditional optimum of a quadratic functional*. Such problem *always* has a solution, and a *fast* algorithm has been found for the search of this functional's saddle point.

The described principle may be used for the development of a universal package of programs for *fast computation* of arbitrarily structured and configured electromechanical systems.

So, the nature gives us by the said principle a certain functional. The second Kirchhoff's law equations follow from the optimization of this functional with constraints in the form of the first Kirchhoff's law equations. So naturally the optimization of the said functional and the solution of the system of Kirchhoff's law equations both lead to the same result.

The proposed method extends to partial differential equations, including also the Maxwell equations.

In essence we are presenting a generalization of a known Lagrange formalism – an universal method of physical equations derivation from the least action principle. However, the Lagrange formalism is applicable only to those systems where the full energy (the sum of kinetic and potential energies) is kept constant. It does not reflect the fact that in real systems the full energy (the sum of kinetic and potential energies) decreases during motion, turning into other types of energy, for example,

---

into thermal energy  $Q$ , i. e. there occurs energy dissipation. Thus, the presented formalism is extended on dissipative systems.

The book consists of **9** chapters.

In **Chapter 1** the electric circuit with RCL-elements is considered and a functional from the split function of charges  $x$  and  $y$  is formulated for this circuit. It is shown that the said functional is maximized as a function of  $x$  and minimized as a function of  $y$ . The sum of the optimal values of  $x$  and  $y$  is equal to the observed function of charges  $q$ . A computational method of searching for the functional's saddle point is presented.

In **Chapter 2** the extremum principle for functional of *split* function of currents  $v$  and  $w$  is *similarly considered*. It is shown that the said functional is being maximized as the function of  $v$  and minimized as the function of  $w$ . The sum of the optimal values of  $v$  and  $w$  is equal to the observed function of currents  $g$ . A computing method of searching for the functional's saddle point is presented.

In **Chapter 3** the electric circuits are supplemented by instantaneous current values transformers. Such transformers were originally explored by Dennis and will in future be called Dennis transformers. It is shown that in this case for electric circuit there also exist functionals from split functions of charge and of current. The first Kirchhoff's law equations serve as constraints in the search of saddle point for these functionals. The existence of second Kirchhoff's law equations follow from the existence of saddle points for these functionals. Then the circuits are modified in such a way that they become mathematically equivalent to simple RCL-circuits and may be described by functionals without constraints. The calculation of such circuits (called unconstrained) becomes significantly simpler. Then we shall consider the so called integral transformers and circuits containing them. These transformers present a certain generalization of Dennis transformers, and in sinusoidal current circuits they are equivalent to transformers with a complex turn ratio.

In **Chapter 4** a method is proposed for finding such functions of charges and currents, that their optimal values provide the optimum of the two functionals *simultaneously*. The physical interpretation of the functionals is considered, and it is shown that in the electric circuit the influence of thermal and electromagnetic energy is optimized simultaneously.

In **Chapter 5** the algorithms of simultaneous optimization of the said functionals are described. The most commonly encountered types of voltage and current sources are considered as the functions of time –

sinusoidal, periodical and step functions. The same functions may be viewed as permutation actions in a system of differential equations, whose solution amounts to the electric circuit calculation with the aid of the proposed method. It is shown that the solution of linear algebraic equation system also amounts to calculation of an electric circuit with sinusoidal currents, using the suggested method.

**Chapter 6** discusses some concepts of the Pontryagin's maximum principle. It is shown that this principle may be used for the electrical circuit functional optimization. Thereby it is established that the considered variational principle may be extended also for discontinuous functions. This argument was used above in the description of discontinuous functions calculation method. Further we shall describe an algorithm of electrical circuit calculation, based on the combination of variational principle and maximum principle.

In **Chapter 7** we consider the analogy between the presented and the Lagrange formalism. Then we turn to the discussion of electromechanical systems. The electric circuit is complemented by some electromechanical elements, which involve, along with currents and charges, some "foreign" variables, such as coordinates, velocities, accelerations, forces, moments, temperature, pressure etc, describing the non-electric processes – mechanical, thermal, hydraulic. A system of equation is built, describing a system of electromechanical elements, connected into an electric circuit. It is shown that such system of equations is also equivalent to the conditions of existence of two functionals, similar to the functionals for electric circuits. The optimum principle for these functionals in some particular cases is transformed into the principle of minimal action.

In **Chapter 8** we are dealing with electric circuits, which are described by partial differential equations – electric lines, planes, volumes. We consider classic and special partial differential equations. We show that for them it is also possible to build functionals, and the search for these functionals extremum is equivalent to the solution of these equations.

In **Chapter 9** it is proved that there exists a functional for which Maxwell equations are the necessary and sufficient conditions of global extremum existence, and this extremum is a saddle point. The subject is the computational aspect which is illustrated by detailed examples of computations for various electromagnetic fields. The method allows to formulate and to solve the sort of Maxwell equations systems that have solutions with unusual physical interpretation:

- longitudinal electromagnetic waves,

- standing waves in the absence of energy exchange between the electric and magnetic component
- electric waves in the absence of magnetic waves and vice versa.

In **Chapter 10** we present a new variational extremum principle of general action, which extends the Lagrange formalism to dissipative systems. We show that this principle is applicable to electrical engineering, mechanics with regard to friction, electrodynamics and hydrodynamics. The proof is in the results stated in the previous chapters. The proposed variational principle is a new formalism, which permits to build a functional with one optimum saddle line for various physical systems. Moreover, the new formalism is not only universal method of deducing physical equations from a certain principle, but also a computational method for these equations.

The book includes numerous examples. Part of them are M-functions of the MATLAB system. These programs comprise a significant part of the book, as a part of computational formulas is simply included into the programs. It was possible because MATLAB language is nearly as laconic as traditional mathematical language, particularly in the part concerned with operations with vectors and matrices which are being widely used in this book.

The book is accompanied by annex [52]. It contains **the open codes** of the mentioned programs of MATLAB and DERIVE systems. This annex is **not necessary** to understand the theory.

# Chapter 1. RCL-circuits with Electric Charges

---

## 0. Introduction

Henceforth we shall denote as  $R$ ,  $L$ ,  $C$  resistance, inductivity and capacitance accordingly. Besides, instead of capacitance  $C$  we shall often use the parameter  $S=1/C$  to simplify the matrix expressions. The first and second derivative with respect to time will be denoted by one or two strokes, accordingly.

Consider first a  $CL$ -circuit without resistance. It is described by the equation:

$$Sq + Lq'' - E = 0, \quad (a)$$

where

- $q$  – the charge, an unknown function of time  $t$  with continuous second derivatives,
- $E$  – a known function of  $t$ .

**Example 1.** Consider an equation

$$Sq + Lq'' - E = 0.$$

The solution of the corresponding homogeneous equation  $Sq + Lq'' = 0$  looks as [16]

$$q = c_1 \text{Cos}(\beta \cdot t) + c_2 \text{Sin}(\beta \cdot t),$$

where  $c_1$ ,  $c_2$  - arbitrary constants,  $\beta = \pm\sqrt{-S/L}$ .

Let  $E = u \cdot e^{\alpha \cdot t}$ . WE can see that a particular solution in this case is  $q = m \cdot E$ , where  $m = \frac{1}{S + \alpha^2 L}$ . The same solution will be for

$E = u \cdot \text{Sh}(\alpha \cdot t)$  or  $E = u \cdot \text{Sin}(\alpha \cdot t)$ , etc. Consequently, the general solution of the initial equation for such cases will be

$$q = c_1 \text{Cos}(at) + c_2 \text{Sin}(at) + mE.$$

Let us consider the functional



$$F(q) = \int_0^T \left( \frac{1}{2} S q^2 - \frac{1}{2} L q'^2 - E q \right) dt, \quad (b)$$

It is easy to see that for the functional (b) the equation (a) is an Euler's equation – the necessary condition of this functional's global minimum [16].

The existence of global optimum of this functional permits us to use the gradient descent method for solving the equation (a). To do it for given values of the function  $q$  its new value is found by the formula

$$q_n = q - ap,$$

where

$p$  – variation of function  $q$ , computed by (a),

$a$  – a constant.

When the function changes from  $q$  to  $q_n$  the functional (b) changes by

$\Delta F = F(q_n) - F(q)$ . Further we have:

$$\begin{aligned} \frac{\partial \Delta F}{\partial a} &= \frac{\partial F(q_n, q'_n)}{\partial a} = \int_0^T \frac{\partial f(q_n, q'_n)}{\partial a} dt = \\ &= \int_0^T \left[ \frac{\partial f(q_n, q'_n)}{\partial q_n} \cdot \frac{\partial q_n}{\partial a} + \frac{\partial f(q_n, q'_n)}{\partial q'_n} \cdot \frac{\partial q'_n}{\partial a} \right] dt = \\ &= \int_0^T \left[ -p \frac{\partial f(q_n, q'_n)}{\partial q_n} - p' \frac{\partial f(q_n, q'_n)}{\partial q'_n} \right] dt. \end{aligned}$$

Besides, we have:

$$\frac{\partial^2 \Delta F}{\partial a^2} = \int_0^T \left[ p \frac{\partial^2 f(q_n, q'_n)}{\partial q_n^2} p + p' \frac{\partial^2 f(q_n, q'_n)}{\partial q_n'^2} p' \right] dt.$$

The optimal size of step  $a$  is determined from the condition  $A + Ba = 0$ ,

where  $A = \left( \frac{\partial \Delta F}{\partial a} \right)_{a=0}$ ,  $B = \left( \frac{\partial^2 \Delta F}{\partial a^2} \right)_{a=0}$  or

$$\begin{aligned} A &= \int_0^T \left[ -p \frac{\partial f(q, q')}{\partial q} - p' \frac{\partial f(q, q')}{\partial q'} \right] dt, \\ B &= \int_0^T \left[ p \frac{\partial^2 f(q, q')}{\partial q^2} p + p' \frac{\partial^2 f(q, q')}{\partial q'^2} p' \right] dt. \end{aligned}$$

Therefore,

$$A = \int_0^T [-Sq p + Lq' p' + Ep] dt ,$$

$$B = \int_0^T [Sp^2 - Lp'^2] dt .$$

The iterative process permits to find the optimal value of  $q$ . The stop sign will be  $p \approx 0$ . On each iteration:

- The gradient  $p$  with respect to (a) with given function  $q$  is computed;
- The coefficients  $A$  and  $B$  with given  $p$  and  $q$  are computed;
- The new value of  $q = q - ap$ , where  $a = -A/B$ , or

$$q =: q + \frac{A}{B} p \tag{c}$$

is computed.

**Example 2.** Continuing example 1, let us find  $q$  by the stated method. On the first iteration  $q=0$ , and hence,

$$p = Sq + Lq'' - E = -E , \quad p' = -\alpha \cdot E ,$$

$$B = \left( S - \alpha^2 L \right)_0^T E^2 dt , \quad A = \int_0^T E^2 dt ,$$

$$q = \frac{A}{B} (-E) \text{ or } q = kE, \text{ where } k = \frac{1}{S + \alpha^2 L} .$$

Generally, if on a certain iteration  $q = hE$ , then

$$p = Sq + Lq'' - E = \left( Sh + \alpha^2 hL - 1 \right) E = nE ,$$

$$A = \int_0^T (-Sq p + Lq' p' + Ep) dt = n \left( Sh + \alpha^2 Lh + 1 \right)_0^T E^2 dt ,$$

$$B = \int_0^T [Sp^2 - Lp'^2] dt = n^2 \left( S - \alpha^2 L \right)_0^T E^2 dt ,$$

And the new value of the function

$$q =: q + \frac{A}{B} p = hE + \frac{n \left( Sh + \alpha^2 Lh + 1 \right)}{n^2 \left( S - \alpha^2 L \right)} nE = \frac{E}{S - \alpha^2 L} ,$$

i.e., as after the first iteration,  $q = kE$ , where  $k = \frac{1}{S - \alpha^2 L}$ . This solution differs from the final solution, obtained in the example 1, and has the form  $q = m \cdot E$ , where  $m = \frac{1}{S + \alpha^2 L}$ .

Let us consider the functional

$$F_1(q) = \int_0^T \left( \frac{1}{2} S q^2 + \frac{1}{2} L q'^2 - E q \right) dt, \quad (c)$$

which differs from the functional (b) by the sign before the second term. We shall call the functional (c) *conjugate* with regard to the *primary* functional (b). Let us consider now the descent by gradient (a) in the conjugate functional (c). It is easy to see that in this case

$$A_1 = \int_0^T [-Sqp - Lq'p' + Ep] dt,$$

$$B_1 = \int_0^T [Sp^2 + Lp'^2] dt.$$

These coefficients differ from the coefficients  $A$  and  $B$  by their sign before the second term.

**Example 3.** Continuing the example 1, let us find the function  $q$  by the stated method of descent by gradient (a) in the conjugate functional (c). On the first iteration  $q=0$  and further,

$$p = Sq + Lq'' - E = -E, \quad p' = -\alpha \cdot E,$$

$$B_1 = (S + \alpha^2 L) \int_0^T E^2 dt, \quad A_1 = -\int_0^T E^2 dt,$$

$$q = \frac{A_1}{B_1} (-E) \text{ or } q = mE, \text{ where } m = \frac{1}{S + \alpha^2 L},$$

This solution is similar to the solution obtained in the example 1. Generally, if on a certain iteration  $q=hE$ , then

$$p = Sq + Lq'' - E = (Sh + \alpha^2 hL - 1) E = nE,$$

$$A_1 = \int_0^T (-Sqp - Lq'p' + Ep) dt = n \left( -Sh - \alpha^2 Lh + 1 \right) \int_0^T E^2 dt,$$

$$B_1 = \int_0^T [Sp^2 + Lp'^2] dt = n^2 (S + \alpha^2 L) \int_0^T E^2 dt,$$

And the new value of function

$$q =: q + \frac{A_1}{B_1} p = hE + \frac{n \left( -Sh - \alpha^2 Lh + 1 \right) nE}{n^2 (S + \alpha^2 L)} = \frac{E}{S + \alpha^2 L},$$

i.e., as after the first iteration, this solution is similar to the solution obtained in the example 1.

Thus, moving by the conjugate functional (c) in the direction of the primary functional's (b) gradient (a) leads to the minimal value of the primary functional (b).

We shall use this rule in future.

## 1. Series RCL-circuit

Let us consider the functional

Further we shall designate the first and the second derivatives with respect to time by one or two strokes correspondingly. Consider a functional

$$F(x, y) = \int_0^T f(x, y) dt, \quad (1)$$

where

$$f(x, y) = \left\{ \begin{array}{l} S(x^2 - y^2) - L(x'^2 - y'^2) \\ + R(xy' - x'y) - E(x - y) \end{array} \right\}, \quad (2)$$

- $x, y$  – unknown functions of time  $t$  with continuous second derivatives,
- $E$  – a known function of  $t$ ,
- $S, L, R$  – positive numbers.

Let us find the necessary conditions of this functional's extremum [7]:

$$\frac{\partial f}{\partial x} - \frac{d}{dt} \left( \frac{\partial f}{\partial x'} \right) = 0, \quad \frac{\partial f}{\partial y} - \frac{d}{dt} \left( \frac{\partial f}{\partial y'} \right) = 0$$

or

$$2Sx + 2Lx'' + 2Ry' - E = 0, \quad (3)$$

$$2Sy + 2Ly'' + 2Rx' - E = 0. \quad (4)$$

Let us find also:

$$\frac{\partial^2 f}{\partial x'^2} = -2L \leq 0, \quad (5)$$

$$\frac{\partial^2 f}{\partial y'^2} = 2L \geq 0. \quad (5a)$$

Consequently, the extremal defined by the equations (3) and (4) provides a *global weak maximum* of the function  $x$  and a *global weak minimum* of the function  $y$  for the functional (1) and (2) (equations (3) and (4) are necessary, and equations (5, 5a) - sufficient conditions for this [7]). It means that there exist optimal functions  $x_0$  and  $y_0$ , presenting a solution of the system of differential equations (3) and (4), and providing an extremal value  $F_0 = F(x_0, y_0)$  for the functional (1) and (2). The optimality of functions  $x_0$  and  $y_0$  becomes apparent when comparing

the values of the functional for optimal and non-optimal functions and their derivatives.

The optimal functions fulfill the condition:

$$x_0 = y_0, \quad (6)$$

which follows from the symmetry of conditions (3) and (4) and may be strictly proved on changing these equations to operator form [9].

Adding up the equations (3) and (4), we get

$$Sq + Lq'' + Rq' - E = 0, \quad (7)$$

where

$$q = x + y. \quad (8)$$

It means that the functional (1) and (2) has its optimum on the functions  $x$  and  $y$ , whose sum satisfies the equation (7). This functional has an optimal saddle point, in which the equations (6), (7) and (8) are satisfied. Equation (7) is the equation of RCL-circuit connected to a voltage source  $E$ , where  $q'$  - the current in this circuit. Therefore in the RCL-circuit the extremum principle for  $F$ , defined by (1) and (2), is objectively valid, and the equation (7) is the consequence of this principle. The integrand (2) of functional (1) has the dimension of energy. Thus, as the interpretation of this principle we may assume that the value optimized in the electrical circuit represent an algebraic sum of electric, magnetic, thermal energy and the potential energy of the voltage source.

**Remark 1.** Let us consider also the case when the values  $S$ ,  $R$  are functions  $S(t)$ ,  $R(t)$  of independent variable  $t$ . In the expression (2) the first term does not contain operators of differentiation or integration. Therefore the value  $S$  may be a function  $S(t)$  of independent variable  $t$  without any change in the functional. To include the function  $R(t)$  into the functional, it should be changed in such a way, that for it, as before, the stationary line would be represented by the equation (7). It is easy to see that such functional will be as follows:

$$f(x, y) = \left\{ \begin{aligned} & \left( S(t) + \frac{1}{2} \frac{dR(t)}{dt} \right) (x^2 - y^2) - L \cdot (x'^2 - y'^2) \\ & + R \cdot (xy' - x'y) - E \cdot (x - y) \end{aligned} \right\}. \quad (8a)$$

This remark will be used in future in the process of solution of differential equations with spatial coordinates as independent variables.

## 2. The Computing Algorithm for RCL-circuit

The existence of global optimum allows the use of gradient descent method for electric circuit calculation. The idea of this method is as follows. For the given values of  $x$  and  $y$  their new values are calculated according to formulas:

$$x_n = x - ap, \quad (9)$$

$$y_n = y + bh, \quad (10)$$

where

$p$  and  $h$  – variations of functions  $x$  and  $y$ , calculated by (3) and (4),

$a$  and  $b$  – constants.

The direction of descent is determined by the gradients  $p$  and  $h$  of the *primary* functional (1) with integrand (2), while moving by *conjugate* functional with the integrand

$$f(x, y) = \left\{ \begin{array}{l} S(x^2 - y^2) + L(x'^2 - y'^2) \\ + R(xy' - x'y) - E(x - y) \end{array} \right\}.$$

This function differs from (1) only by the sign before the second term. When functions change from  $x$  to  $x_n$  and from  $y$  to  $y_n$ , functional changes by  $\Delta F = F(x_n, y_n) - F(x, y)$ . Further we have:

$$\begin{aligned} \frac{\partial \Delta F}{\partial a} &= \frac{\partial F(x_n, y_n, x'_n, y'_n)}{\partial a} = \int_0^T \frac{\partial f(x_n, y_n, x'_n, y'_n)}{\partial a} dt = \\ &= \int_0^T \left[ \frac{\partial f(x_n, y_n, x'_n, y'_n)}{\partial x_n} \cdot \frac{\partial x_n}{\partial a} + \frac{\partial f(x_n, y_n, x'_n, y'_n)}{\partial x'_n} \cdot \frac{\partial x'_n}{\partial a} \right] dt = \\ &= \int_0^T \left[ -p \frac{\partial f(x_n, y_n, x'_n, y'_n)}{\partial x_n} - p' \frac{\partial f(x_n, y_n, x'_n, y'_n)}{\partial x'_n} \right] dt, \\ \frac{\partial^2 \Delta F}{\partial a^2} &= \int_0^T \left[ p \frac{\partial^2 f(x_n, y_n, x'_n, y'_n)}{\partial x_n^2} p + p' \frac{\partial^2 f(x_n, y_n, x'_n, y'_n)}{\partial x_n'^2} p' \right] dt. \end{aligned}$$

The optimal value of  $a$  is determined from the condition  $A' + B'a = 0$ ,

where  $A' = \left( \frac{\partial \Delta F}{\partial a} \right)_{a=0}$ ,  $B' = \left( \frac{\partial^2 \Delta F}{\partial a^2} \right)_{a=0}$  or

$$A' = \int_0^T \left[ -p \frac{\partial f(x, y, x', y')}{\partial x} - p' \frac{\partial f(x, y, x', y')}{\partial x'} \right] dt,$$

$$B' = \int_0^T \left[ p \frac{\partial^2 f(x, y, x', y')}{\partial x^2} p + p' \frac{\partial^2 f(x, y, x', y')}{\partial x'^2} p' \right] dt.$$

Thus,

$$A' = \int_0^T [-2Sxp - 2Lx'p' + R(p'x - px') + Ep] dt,$$

$$B' = \int_0^T [2Sp^2 + 2Lp'^2] dt.$$

Similarly, the optimal value of  $b$  is determined from the condition  $A'' + B''b = 0$ , where

$$A'' = \int_0^T [2Syh + 2Ly'h' - R(h'y - hy') - Eh] dt,$$

$$B'' = \int_0^T [-2Sh^2 - 2Lh'^2] dt.$$

The iterative process leads us to the optimal values of  $x$  and  $y$ . Indication of stopping is  $p \approx 0$  and  $h \approx 0$ . If the iterative process begins from  $x_0 = y_0$ , then by symmetry,  $p_0 = -h_0$ . Also  $p'h - ph' = 0$  and the last two conditions  $A' + B'a = 0$  and  $A'' + B''a = 0$  turn into the following equivalent conditions, where  $A' = -A'' = A$ ,  $B' = -B'' = B$  and  $a = b$ . As  $x = y = q/2$ , the gradient of the function  $q$  is equal to

$$p_q = 2p. \quad (10a)$$

Further we have:

$$B = \int_0^T [2Sp^2 + 2Lp'^2] dt, \quad (11)$$

$$A = \int_0^T [-Sqp - Lq'p' + R(p'q - pq')/2 + Ep] dt, \quad (12)$$

$$p = Sq + Lq'' + Rq' - E. \quad (13)$$

Thus, the iterative process of finding the extreme value of the functional (1) allows to find the function  $q$ . During every iteration

- The gradient  $p$  is calculated by (13) for the given function  $q$ ;
- The coefficient  $a = -A/B$  is calculated by (11) and (12) for given  $p$  and  $q$ ;
- The new value of the function  $q$  is calculated:

$$q =: q - 2ap \quad (13a)$$

or

$$q =: q + \frac{2A}{B} p. \quad (13b)$$

### 3. The Equations for General-Form Electric Circuit

Let us consider a general-form electric circuit and note there two types of branches:

1. A branch with current source  $H_k$ , placed between the node and the “ground”,
2. A series RCL-circuit with elements  $R_k, S_k, L_k, E_k$ , placed between two nodes.

We shall assume that branches of the second type are linked in addition by mutual inductances  $M_{km}$ . An example of such circuit is shown in the fig. 1.

Using the line of reasoning similar to [2], we can show that such electric circuit is described by the following system of equations:

$$Sq + Mq'' + Rq' - E + N^T \varphi = 0, \tag{14}$$

$$Nq' + H = 0, \tag{15}$$

where

$H, q'$  - vectors of currents in branches of the first and second type;

$E$  – generated voltage vector for branches of the second type;

$\varphi$  - potentials vector for branches of the second type;

$N$  – incidence matrix with the elements 1, 0, -1;

$S, R, M$  – matrixes of the type

$$S = \text{diag}[S_1 S_2 \dots S_k \dots] \tag{16}$$

$$R = \text{diag}[R_1 R_2 \dots R_k \dots] \tag{17}$$

$$M = \begin{bmatrix} L_1 & M_{12} & M_{13} & \dots M_{1k} & \dots & M_{1m} & \dots \\ M_{21} & L_2 & M_{23} & \dots M_{2k} & \dots & M_{2m} & \dots \\ \dots & \dots & \dots & \dots \dots & \dots & \dots & \dots \\ M_{k1} & M_{k2} & M_{k3} & \dots L_k & \dots & M_{km} & \dots \\ \dots & \dots & \dots & \dots & \dots & \dots & \dots \end{bmatrix}. \tag{18}$$

In this system equation (15) describes the first Kirchhoff's law, equation(14) – the second Kirchhoff's law. In this system  $H$  and  $E$  are known vector-functions of time  $t$ , and the vector-function of time  $q(t)$  is the required function.



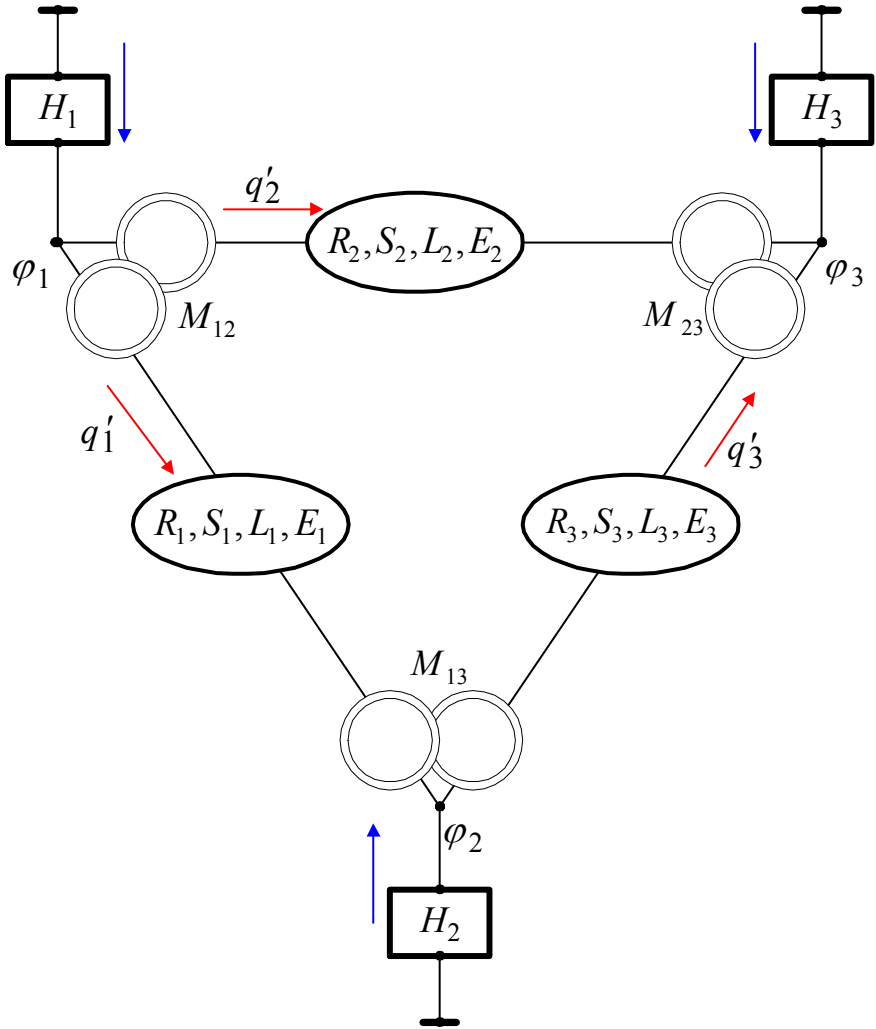

Fig. 1. An Example of General-Form Electric Circuit

## 4. The Functional for General-Form Electric Circuit

Let us consider vector-functions of time  $x(t)$ ,  $y(t)$ ,  $\vartheta(t)$ ,  $\Psi(t)$ , satisfying equations (8) and the equation

$$\varphi = \vartheta' + \Psi' \quad (19)$$

System of equations (14), (15) may be rewritten in the following form:

$$2Sx + 2Mx'' + 2Ry' - E + 2N^T \vartheta' = 0, \quad (20)$$

$$2Sy + 2My'' + 2Rx' - E + 2N^T \Psi' = 0, \quad (21)$$

$$2Nx' + H = 0, \quad (22)$$

$$2Ny' + H = 0, \quad (23)$$

Consider now the functional (1), where

$$f(x, y) = \left\{ \begin{array}{l} x^T Sx - y^T Sy - x'^T Mx' + y'^T My' + \\ + x^T Ry' - x'^T Ry - E^T (x - y) + \\ + \vartheta^T (2Nx' + H) + \Psi^T (2Ny' + H) \end{array} \right\} \quad (24)$$

and consider the problem of seeking an extremum of this functional. The necessary conditions of extremum in this case take the form of equations (20)-(23).

Adding up the equations (20) and (21), we get (14), and adding up (22) and (23), we get (15). Further we have:

$$\frac{\partial^2 f}{\partial x'^2} = -2M, \quad (25)$$

$$\frac{\partial^2 f}{\partial y'^2} = 2M. \quad (25a)$$

Let us consider now a quadratic form  $Q = x'^T Mx'$ , being a part of the functional (1) and (24). Later in p. 6 it will be shown that  $Q \geq 0$ , which means that the matrix  $M$  is positive definite. Therefore and from (25, 25a) it follows [7], that the functional (1), (24) has a saddle point, where a *global weak maximum* of the function  $x$  and a *global weak minimum* of the function  $y$  are achieved. The arguments for this deduction are similar to those of p. 1, whence it follows that the optimum of this functional is reached with

$$x_0 = y_0, \quad \vartheta_0 = \Psi_0, \quad q_0 = x_0 + y_0, \quad \varphi_0 = \vartheta_0 + \Psi_0.$$

## 5. The Computing Algorithm for General-Form Electric Circuit

By analogy with p. 2 we shall discuss now the iterative process in which the new values of variables  $x$ ,  $y$ ,  $g$ ,  $\Psi$  are calculated by the formulas:

$$x_n = x + a_x p_x, \quad (26)$$

$$y_n = y + a_y p_y, \quad (27)$$

$$g'_n = g' + a_g p_g, \quad (28)$$

$$\Psi'_n = \Psi' + a_\Psi p_\Psi, \quad (29)$$

where

$p$  – variations of vector-functions  $x$ ,  $y$ ,  $g$ ,  $\Psi$ , calculated by (20)-(23),

$a$  – the size of steps by these vector-functions.

By analogy with p. 2 the optimal value of  $a_x$  is determined from the

$$\text{condition } \frac{\partial \Delta F}{\partial a_x} = 0 \text{ or } \int_0^T \left[ p_x^T \frac{\partial f(t)}{\partial x_n} + p_x'^T \frac{\partial f(t)}{\partial x'_n} \right] dt = 0.$$

So the optimal value of  $a_x$  is determined from the condition

$$\int_0^T \left[ \begin{aligned} & 2p_x^T Sx - 2p_x'^T Mx' - p_x'^T Ry + p_x^T Ry' - p_x^T E + \\ & + 2a_x (p_x^T Sp_x - p_x'^T Mp_x') - a_y (p_x'^T Rp_y - p_x^T Rp_y') \end{aligned} \right] + 2p_x'^T N^T (g + a_g p_g) dt = 0,$$

Similarly, the optimal value of  $a_y$  is determined from the condition

$$\int_0^T \left[ \begin{aligned} & 2p_y^T Sy - 2p_y'^T My' - p_y'^T Ry + p_y^T Ry' - p_y^T E + \\ & + 2a_x (p_y^T Sp_y - p_y'^T Mp_y') - a_y (p_y'^T Rp_x - p_y^T Rp_x') \end{aligned} \right] + 2p_y'^T N^T (\Psi + a_\Psi p_\Psi) dt = 0,$$

the optimal value of  $a_g$  is determined from the condition

$$\int_0^T \left[ 2p_g^T N(x + a_x p_x) \right] dt = 0,$$

optimal value of  $a_\Psi$  is determined from the condition

$$\int_0^T \left[ 2p_{\Psi}^T N (y + a_y p_y) \right] dt = 0.$$

If the iterative process begins with  $x_0 = y_0$ ,  $g_0 = \Psi_0$ , then by symmetry  $p_x = p_y$ ,  $p_g = p_{\Psi}$ . Also  $(p_y'^T R p_x - p_y^T R p_x') = 0$  and the above named conditions change into

$$\begin{aligned} A_1 + A_2 a_x + A_3 a_g &= 0, & A_1 + A_2 a_y + A_3 a_{\Psi} &= 0, \\ A_4 + A_5 a_x &= 0, & A_4 + A_5 a_y &= 0, \end{aligned}$$

where

$$A_1 = \int_0^T \left[ \begin{aligned} &2p_x^T Sx - 2p_x'^T Mx' - p_x'^T Ry + \\ &p_x^T Ry' - p_x^T E + 2p_x'^T N^T g' \end{aligned} \right] dt,$$

$$A_2 = \int_0^T \left[ 2(p_x^T S p_x - p_x'^T M p_x') \right] dt,$$

$$A_3 = \int_0^T \left[ 2p_x'^T N^T p_g \right] dt,$$

$$A_4 = \int_0^T \left[ 2p_{\Psi}^T N y \right] dt,$$

$$A_5 = \int_0^T \left[ 2p_{\Psi}^T N p_y \right] dt.$$

Hence it follows that

$$a_q = a_x = a_y = -A_4/A_5,$$

$$a_{\varphi} = a_g = a_{\Psi} = (A_2 A_4 - A_1 A_3)/A_3^2,$$

$$x = y = q/2,$$

$$g' = \Psi' = \varphi/2,$$

$$p_q = p_x = p_y = Sq + Mq'' + Rq' - E - N^T \varphi,$$

$$p_{\varphi} = p_g = p_{\Psi} = Nq' + H,$$

$$q_n = q + 2a_q p_q,$$

$$\varphi_n = \varphi + 2a_{\varphi} p_{\varphi}.$$

The coefficients may be presented in the following form:

$$A_1 = \int_0^T \left[ \begin{array}{c} p_q^T S q - p_q'^T M q' - \frac{1}{2} (p_q'^T R q + p_q^T R q') \\ - p_q^T E + p_q'^T N^T \varphi \end{array} \right] dt,$$

$$A_2 = \int_0^T \left[ (p_q^T S p_q - p_q'^T M p_q') \right] dt,$$

$$A_3 = \int_0^T \left[ p_q'^T N^T p_\varphi \right] dt,$$

$$A_4 = \int_0^T \left[ p_\varphi^T N q \right] dt,$$

$$A_5 = \int_0^T \left[ p_\varphi^T N q \right] dt.$$

### Special Case 1. Circuit with One Node.

Let us consider a circuit with one node (and, probably, with an mutual inductances matrix). The matrix  $N = 0$ ,

$$p_q = S q + M q'' + R q' - E,$$

$$a_q = - A_1 / A_2,$$

at that

$$A_1 = \int_0^T \left[ p_q^T S q - p_q'^T M q' - \frac{1}{2} (p_q'^T R q + p_q^T R q') - p_q^T E \right] dt.$$

### Special Case 2. Circuit with One Branch

Let us consider a circuit with one branch, and, consequently, with one node. At the initial moment we have:  $q=0$ ,  $p_q = -E$ . At this

$$A_1 = - \int_0^T E^2 dt, \quad A_2 = 2 \int_0^T (S E^2 - L E'^2) dt,$$

$$a_q = \int_0^T (E^2) dt \Big/ 2 \int_0^T (S E^2 - L E'^2) dt.$$

**Special Case 3. Circuit with One Branch and Voltage Source.**

Let us consider a circuit with one branch, connected to a voltage source. At the initial moment we have:

$$q = 0, \quad \varphi = 0, \quad p_q = -E, \quad p_\varphi = I, \quad N = 1.$$

Also

$$\begin{aligned} A_1 &= -\int_0^T E^2 dt, & A_2 &= 2\int_0^T (SE^2 - LE'^2) dt, \\ A_3 &= -2\int_0^T E' Idt, & A_4 &= 0, \\ A_5 &= -2\int_0^T E Idt, & a_q &= 0, \\ a_\varphi &= \frac{-A_1}{A_3} = \frac{-\int_0^T E^2 dt}{2\int_0^T E' Idt}. \end{aligned}$$

## 6. The Properties of mutual Inductances Matrix

Let us show, that for real electric circuits the matrix  $M = \{M_{km}\}$  is positive definite [9]. The element creating mutual inductance  $M_{km}$ , creates also inductances  $L_k^{km}$  и  $L_m^{km}$  in the branches  $k$  and  $m$  correspondingly. Let us assume that, for instance, such element is a transformer with the number of coils  $n_k$  and  $n_m$  in the windings. Then

$$L_k^{km} = an_k^2, \quad L_m^{km} = an_m^2, \quad M_{km} = an_k n_m, \tag{31}$$

where  $a$  – a constant value. Thus, the mutual inductance is

$$M_{km} = \sqrt{L_k^{km} L_m^{km}}, \quad M_{mk} = M_{km}, \tag{32}$$

full inductance of the  $k$ -branch is

$$L_k = M_{kk} = L_k^o + \sum_{m \neq k} L_k^{km}, \tag{33}$$

where  $L_k^o$  – inductance of an element which does not create an mutual inductance.

Let us consider now a quadratic form  $Q = x'^T M x'$ . Obviously,

$$Q = \sum_k L_k x'_k{}^2 + \sum_k \sum_{m>k} (M_{km} + M_{mk}) \cdot x'_k x'_m .$$

From (31), (32), (33) it follows that

$$Q = \sum_k L_k x'_k{}^2 + \sum_k \sum_{m>k} (M_{km} \cdot x'_k x'_m + L_k^{km} x'_k{}^2 + L_m^{km} x'_m{}^2)$$

or

$$Q = \sum_k \left[ L_k x'_k{}^2 + \sum_{m>k} \left( x'_k \sqrt{L_k^{km}} + x'_m \sqrt{L_m^{km}} \right)^2 \right] .$$

Thus,  $Q > 0$ , which means that the matrix  $M = \{M_{km}\}$  is positive definite. This property of the matrix has been used above.

# Chapter 2. RCL-circuits with Electric Currents

---

## 1. The Functionals of Integral Functions

Previously we have described the equations of circuits with respect to the charge  $q$ . Further we shall consider the equations of circuits with respect to the current  $g$ . First let us consider an  $R$ -circuit without inductivity and capacitance. It is described by the equation

$$Rg - E = 0, \tag{a}$$

where

- $g$  – the current, an unknown function of time  $t$  with continuous second derivatives,
- $E$  – a known function of time  $t$ .

It is easy to see that for the functional

$$F(g) = \int_0^T \left( \frac{1}{2} Rg^2 - Eg \right) dt, \tag{b}$$

The equation (a) is the Euler's equation – the necessary condition of this functional's minimum [16]:

Let us introduce the following notations:

$$Z'_t = dZ/dt, \quad \hat{Z} = \int_0^t Z dt.$$

There is a known Euler's formula for the variation of a functional of function  $f(y, y', y'', \dots)$  [7]. *By analogy* we shall now write a similar formula for function  $f(\dots, \hat{y}, y, y', y'', \dots)$ :

$$\text{var} = \dots - \int_0^t f'_y \hat{y} dt + f'_y - \frac{d}{dt} f'_{y'} + \frac{d^2}{dt^2} f'_{y''} - \dots \tag{1}$$

In particular, if  $f() = xy'$ , then  $\text{var} = -x'$ ; if  $f() = x\hat{y}$ , then  $\text{var} = -\hat{x}$ .



## 2. Integral Equations of RCL-circuit.

The equations of a series RCL-circuit with respect to the current  $g$  and its derivatives has the following form:

$$S\hat{g} + Lg' + Rg - E = 0. \quad (2)$$

In the same way as before this equation may be substituted by two equations of the form:

$$2S\hat{w} + 2Lw' + 2Rv - E = 0 \quad (3)$$

$$2S\hat{v} + 2Lv' + 2Rw - E = 0 \quad (4)$$

where

$$g = v + w \quad (5)$$

Let us now consider the functional

$$F(x, y) = \int_0^T f(v, w) dt, \quad (6)$$

where

$$f(v, w) = \left\{ \begin{array}{l} S(v\hat{w} - \hat{v}w) + L(vw' - v'w) \\ + R(v^2 - w^2) - E(v - w) \end{array} \right\}, \quad (7)$$

- $v, w$  – unknown functions of time  $t$  with continuous second derivatives,
- $E$  – a known function of time  $t$ ,
- $S, L, R$  – positive numbers.

Let us find the necessary conditions of this functional's extremum, using formulas of the preceding section:

$$-\int_0^t f'_v dt + f'_v - \frac{d}{dt} f'_v = 0, \quad -\int_0^t f'_w dt + f'_w - \frac{d}{dt} f'_w = 0,$$

which is equivalent to the formulas (3) and (4). Let us find also

$$\frac{\partial^2 f}{\partial v^2} = 2R \geq 0, \quad \frac{\partial^2 f}{\partial w^2} = -2R \leq 0. \quad (8)$$

Consequently, the extremal defined by the equations (3) and (4) provides a *global strong maximum* by the function  $v$  and a *global strong minimum* by the function  $w$  to the functional (6) и (7) (the equations (3) and (4) are the necessary, and the equations (8) – the sufficient conditions for this [7]). It means that there exist optimal functions  $v_0$  and  $w_0$ , which are the solution of the system of differential equations (3) and (4) and which provide an extremum  $F_0 = F(v_0, w_0)$  to the functional (6) and (7). The optimality of functions  $v_0$  and  $w_0$  shows in the comparison of the functional's other values depending on optimal and non-optimal

functions and their derivatives. The optimal functions satisfy the condition

$$v_0 = w_0, \tag{9}$$

which follows from the symmetry of equations (3) and (4), and may be proved strictly if we turn to operator form of these equations [9]. Adding up the equations (3) and (4), we get equations (2) and (5).

Thus, the functional (6) and (7) has its optimum on such functions  $v$  and  $w$ , the sum of which satisfies the equation (2). This functional has an optimal saddle point, where the conditions (9), (2) and (5) are fulfilled. The equation (2) is the equation of RCL-circuit, connected to voltage source  $E$ , where  $g$  – the current in this circuit. Hence, the principle of extremum of  $F$ , defined by (6) and (7), is objectively fulfilled for the RCL-circuit, and the equation (7) is the consequence of this principle. The integrand (2) of functional (1) has the dimension of energy. This is why in the interpretation of this principle we may assume that the value optimized in the electric circuit represent an algebraic sum of electric, magnetic, thermal energy and the potential energy of the voltage source.

**Remark 1.** In the expression (7) the third term does not contain operators of differentiation and integration. Therefore the value  $R$  may be a function  $R(t)$  of independent variable  $t$ .

This remark will be used in future in the process of solution of differential equations with spatial coordinates as independent variables.

### 3. The Computing Algorithm for Integral Equations of RCL-circuit.

The existence of global optimum allows us to use the gradient descent method. The idea of this method is as follows. Having the given values of  $v$  and  $w$ , their new values are calculated according to formulas:

$$v_n = v - ap, \tag{10}$$

$$w_n = w + bh, \tag{11}$$

where  $p$  and  $h$  – variations of functions  $v$  and  $w$ , calculated by (3) and (4),  $a$  and  $b$  – constants. When the functions vary from  $v$  to  $v_n$  and from  $w$  to  $w_n$ , the function (7) varies by value  $\Delta F = F(v_n, w_n) - F(v, w)$ . Further we have:

$$\begin{aligned}
 \frac{\partial \Delta F}{\partial a} &= \frac{\partial F(v_n, w_n, v'_n, w'_n, \hat{v}_n, \hat{w}_n)}{\partial a} = \int_0^T \frac{\partial f(t)}{\partial a} dt = \\
 &= \int_0^T \left[ \frac{\partial f(t)}{\partial v_n} \cdot \frac{\partial v_n}{\partial a} dt + \frac{\partial f(t)}{\partial v'_n} \cdot \frac{\partial v'_n}{\partial a} + \frac{\partial f(t)}{\partial \hat{v}_n} \cdot \frac{\partial \hat{v}_n}{\partial a} \right] dt = \\
 &= \int_0^T \left[ -p \frac{\partial f(t)}{\partial v_n} - p' \frac{\partial f(t)}{\partial v'_n} - \hat{p} \frac{\partial f(t)}{\partial \hat{v}_n} \right] dt, \\
 \frac{\partial^2 \Delta F}{\partial a^2} &= \int_0^T \left[ p \frac{\partial^2 f(t)}{\partial v_n^2} p + p' \frac{\partial^2 f(t)}{\partial v_n'^2} p' + \hat{p} \frac{\partial^2 f(t)}{\partial \hat{v}_n^2} \hat{p} \right] dt.
 \end{aligned}$$

The optimal value of  $a$  is determined from the condition  $A' + B'a = 0$ ,

where  $A' = \left( \frac{\partial \Delta F}{\partial a} \right)_{a=0}$ ,  $B' = \left( \frac{\partial^2 \Delta F}{\partial a^2} \right)_{a=0}$  or

$$\begin{aligned}
 A' &= \int_0^T \left[ -p \frac{\partial f(t)}{\partial v} - p' \frac{\partial f(t)}{\partial v'} - \hat{p} \frac{\partial f(t)}{\partial \hat{v}} \right] dt, \\
 B' &= \int_0^T \left[ p \frac{\partial^2 f(t)}{\partial v^2} p + p' \frac{\partial^2 f(t)}{\partial v'^2} p' + \hat{p} \frac{\partial^2 f(t)}{\partial \hat{v}^2} \hat{p} \right] dt.
 \end{aligned}$$

Thus

$$\begin{aligned}
 A' &= \int_0^T [pS\hat{w} + pLw' - \hat{p}Sw - p'Lw - 2pRv + pE] dt, \\
 B' &= \int_0^T [2Rp^2] dt.
 \end{aligned}$$

Similarly, the optimal value of  $b$  is determined from the condition  $A'' + B''b = 0$ , where

$$\begin{aligned}
 A &= \int_0^T [-hS\hat{v} - hLv' + \hat{h}Sv + h'Lv + 2hRw - hE] dt, \\
 B'' &= -\int_0^T [2Rh^2] dt.
 \end{aligned}$$

The iterative process enables us to find the optimal values  $v$  and  $w$ . Indication of stopping is  $p \approx 0$  and  $h \approx 0$ . If the iterative process begins with  $v_0 = w_0$  then, by symmetry,  $p_0 = -h_0$ . Also

$$(pS\hat{h} + pLh' - \hat{p}Sh - p'Lh) = 0,$$

$$(-hS\hat{p} - hLp' + \hat{h}Sp + h'Lp) = 0$$

and the last two conditions turn into the following equivalent conditions  $A' = -A'' = A$ ,  $B' = -B'' = B$  and  $a = b$ . As  $v = w = g/2$ , then the gradient of the function  $g$  is

$$p_g = 2p. \quad (11a)$$

Further we have:

$$B = \int_0^T [2Rp^2] dt, \quad (12)$$

$$A = \int_0^T [(+ pS\hat{g} + pLg' - \hat{p}Sg - p'Lg)/2 - pRg + pE] dt, \quad (13)$$

$$p = S\hat{g} + Lg' + Rg - E. \quad (14)$$

So the iterative process of searching for the extremum of the functional (6) enables us to find the function  $g$ . On every iteration:

- The gradient  $p$  is determined from (14) with given function  $g$ .
- The coefficient  $a = -A/B$  is determined from (13) and (12) with given  $p$  and  $g$ .
- The new value of  $g$  is calculated.

$$g =: g - 2ap \quad (14a)$$

or

$$g =: g + \frac{2A}{B} p. \quad (14b)$$

**Remark 2.**

Using the stated gradient descent method for finding the minimum of functional (1.b), we get

$$A_R = \int_0^T (-Rgp + Ep) dt,$$

$$B_R = \int_0^T Rp^2 dt,$$

$$p_R = Rg - E,$$

and the new value of the function  $g$  is

$$g =: g + \frac{A_R}{B_R} p_R. \quad (14c)$$

Notice, that if  $L=C=0$  then the following formulas are valid:  $A_R = A$ ,  $B_R = B/2$ ,  $p_R = p$ . Thus, the formulas (14b) and (14c) are similar.

## 4. The Integral Equations for General-Form Electric Circuit

Let us consider a general-form electric circuit described in the section 1.3. Reasoning by analogy with the preceding argument we may show that such electric circuit may be described by the following system of equations:

$$S\hat{g} + Mg' + Rg - E + N^T \varphi = 0, \quad (15)$$

$$Ng + H = 0, \quad (16)$$

where  $H, g$  - vectors of currents in branches of the first and second type. In this system equation (16) describes the first Kirchhoff's law, equation (15) – the second Kirchhoff's law. In this system  $H$  and  $E$  are known as vector-functions of time  $t$ , and the vector-function of time  $g(t)$  is the required function.

## 5. Functional for Integral Equations of General-form Electric Circuit

We shall consider vector-functions of time  $v(t), w(t), g(t), \Psi(t)$ , satisfying the equations (5) and the equation

$$\varphi = g + \Psi \quad (17)$$

The system of equations (15), (16) may be rewritten in the following form:

$$2S\hat{v} + 2Mv' + 2Rw - E + 2N^T g = 0 \quad (18)$$

$$2S\hat{w} + 2Mw' + 2Rv - E + 2N^T \Psi = 0 \quad (19)$$

$$2Nv + H = 0, \quad (20)$$

$$2Nw + H = 0, \quad (21)$$

Let us consider now the functional (6), where

$$f(v, w) = \left[ \begin{array}{l} v^T S\hat{w} - \hat{v}^T S w + v^T L w' - v'^T L w + \\ + v^T R v - w^T R w - E^T (v - w) + \\ + g(2Nv + H) + \Psi(2Nw + H) \end{array} \right], \quad (22)$$

and the problem of searching for the extremum of this functional. The necessary conditions of extremum in this case have the form of equations (18)-(21).

Adding up the equations (18) and (19), we get (15), and adding up (20) and (21), we get (16). Further we have:

$$\frac{\partial^2 f}{\partial v^2} = R > 0, \quad \frac{\partial^2 f}{\partial w^2} = -R < 0. \quad (23)$$

Therefore [7] it follows, that the functional (6), (22) has a saddle point, where a global weak maximum of the function функции  $v$  and a global weak minimum of the function  $w$  are achieved. The arguments for this deduction are similar to those above, whence it follows that the optimum of this functional is reached with

$$v_0 = w_0, \quad \mathcal{G}_0 = \Psi_0, \quad g_0 = v_0 + w_0, \quad \varphi_0 = \mathcal{G}_0 + \Psi_0.$$

## 6. Computing Algorithm for General-Form Electric Circuit Integral Equations

By analogy with p. 3 let us consider an iterative process in which the new values of  $v$ ,  $w$ ,  $\mathcal{G}$ ,  $\Psi$  are calculated with the aid of following formulas:

$$v_n = v + a_v p_v, \quad (24)$$

$$w_n = w + a_w p_w, \quad (25)$$

$$\mathcal{G}_n = \mathcal{G} + a_g p_g, \quad (26)$$

$$\Psi_n = \Psi + a_\Psi p_\Psi, \quad (27)$$

where

$p$  – variations of vector-functions  $v$ ,  $w$ ,  $\mathcal{G}$ ,  $\Psi$ , calculated by (18-21),

$a$  – the size of steps along these vector-functions.

By analogy with preceding discussions  $a_v$  is determined from the

condition  $\frac{\partial \Delta F}{\partial a_v} = 0$  or

$$\int_0^T \left[ p^T \frac{\partial f(v_n, w_n)}{\partial v_n} + p'^T \frac{\partial f(v_n, w_n)}{\partial v'_n} + \hat{p}^T \frac{\partial f(v_n, w_n)}{\partial \hat{v}_n} \right] dt = 0.$$

Thus, the optimal value of  $a_v$  is determined from the condition

$$\int_0^T \left[ p_v^T S \hat{w} + p_v^T M w' + 2 p_v^T R v - p_v^T E - \hat{p}_v^T S w - p_v'^T M w + \right. \\ \left. + a_w (p_v^T S \hat{p}_w + p_v^T M p_w' - \hat{p}_v^T S p_w - p_v'^T M p_w) + \right. \\ \left. + 2 a_v p_v^T R p_v + 2 p_v^T N^T (\mathcal{G} + a_g p_g) \right] dt = 0,$$

Similarly, the optimal value of  $a_w$  is determined from the condition

$$\int_0^T \left[ p_w^T S \hat{v} + p_w^T M v' + 2 p_w^T R w - p_w^T E - \hat{p}_w^T S v - p_w'^T M v + \right. \\ \left. + a_v (p_w^T S \hat{p}_v + p_w^T M p_v' - \hat{p}_w^T S p_v - p_w'^T M p_v) + \right. \\ \left. + 2 a_w p_w^T R p_w + 2 p_w^T N^T (\Psi + a_\Psi p_\Psi) \right] dt = 0,$$

optimal value of  $a_g$  is determined from the condition

$$\int_0^T \left[ 2 p_g^T N (v + a_v p_v) \right] dt = 0,$$

optimal value of  $a_\Psi$  is determined from the condition

$$\int_0^T \left[ 2 p_\Psi^T N (w + a_w p_w) \right] dt = 0.$$

If the iterative process begins from  $v_0 = w_0$ ,  $\mathcal{G}_0 = \Psi_0$ , then by symmetry

$p_v = p_w$ ,  $p_g = p_\Psi$ . At that

$$(p_v^T S \hat{p}_w + p_v^T M p_w' - \hat{p}_v^T S p_w - p_v'^T M p_w) = 0$$

and the above named conditions turn into

$$B_1 + B_2 a_v + B_3 a_g = 0, \quad B_1 + B_2 a_w + B_3 a_\Psi = 0, \\ A_4 + A_5 a_v = 0, \quad B_4 + B_5 a_w = 0,$$

where

$$B_1 = \int_0^T \left[ p_v^T S \hat{w} + p_v^T M w' + 2 p_v^T R v - p_v^T E - \right. \\ \left. - \hat{p}_v^T S w - p_v'^T M w + 2 p_v^T N^T \mathcal{G} \right] dt, \\ B_2 = \int_0^T \left[ 2 p_v^T R p_v \right] dt, \quad B_3 = \int_0^T \left[ 2 p_v^T N^T p_g \right] dt, \\ B_4 = \int_0^T \left[ 2 p_g^T N v \right] dt, \quad B_5 = \int_0^T \left[ 2 p_g^T N p_w \right] dt.$$

Hence it follows that

$$a_g = a_v = a_w = -B_1 / B_2, \\ a_\Psi = a_g = a_\Psi = (B_2 B_4 - B_1 B_5) / B_3 B_5,$$

$$v = w = g/2,$$

$$\mathcal{G} = \Psi = \varphi/2,$$

$$p_g = p_v = p_w = S\hat{g} + Mg' + Rg - E - N^T \varphi,$$

$$p_\varphi = p_\mathcal{G} = p_\Psi = Ng + H,$$

$$g_n = g + 2a_g p_g,$$

$$\varphi_n = \varphi + 2a_\varphi p_\varphi.$$

The coefficients may be presented in the form

$$B_1 = \int_0^T \left[ \frac{1}{2} \left( p_g^T S \hat{g} + p_g^T M g' - \hat{p}_g^T S g - p_g^T M g \right) + p_g^T R g - p_g^T E + p_g^T N^T \varphi \right] dt,$$

$$B_2 = \int_0^T \left[ p_g^T R p_g \right] dt,$$

$$B_3 = \int_0^T \left[ p_g^T N^T p_\varphi \right] dt,$$

$$B_4 = \int_0^T \left[ p_g^T N g \right] dt,$$

$$B_5 = \int_0^T \left[ p_\varphi^T N p_g \right] dt.$$

### Special Case 1. A Circuit with One Node

Let us consider a special case of circuit with one node (and probably with interinductances matrix). The matrix  $N=0$ ,  $p_g = S\hat{g} + Mg' + Rg - E$ ,  $a_g = -B_1/B_2$ , and

$$B_1 = \int_0^T \left[ p_g^T S g - p_g^T M g' - \frac{1}{2} \left( p_g^T R g + p_g^T R g' \right) - p_g^T E \right] dt.$$

### Special Case 2. A Circuit with One Branch

Let us consider a special case of circuit with one branch, and, consequently, with one node. In the initial moment we have:  $g=0$ ,  $p_g = -E$ . At that



$$B_1 = -\int_0^T E^2 dt,$$

$$B_2 = 2R \int_0^T E^2 dt,$$

$$a_g = 1/2R.$$

### Special Case 3. A Circuit with One Branch and Voltage Source

Let us consider a circuit with one branch, connected to a voltage source. In the initial moment we have:

$$g = 0, \quad \varphi = 0, \quad p_g = -E, \quad p_\varphi = I, \quad N = 1.$$

At that

$$B_1 = -\int_0^T E^2 dt,$$

$$B_2 = 2R \int_0^T E^2 dt,$$

$$B_3 = -2 \int_0^T E I dt,$$

$$B_4 = 0,$$

$$B_5 = B_3.$$

So,

$$a_g = 0,$$

$$a_\varphi = \frac{-B_1}{B_3} = \frac{-\int_0^T E^2 dt}{2 \int_0^T E I dt}.$$

# Chapter 3. Special Transformers in Alternative Current Circuits

---

## 1. Electric Circuit with Dennis Transformers

The electric circuits described below contain instantaneous current values transformers. Such transformers were originally explored by Dennis [2]. Because of this they will in future be called *Dennis transformers* and denoted as DT. Dennis introduced DT as an abstract mathematical construction (for interpreting a quadratic programming problem) and has developed a theory of direct current electric circuits containing DT, resistors, diodes, current and voltage sources. The theory did not include methods of physical realization of DT. Owing to technical complicacy of such realization the circuits with direct current transformers up to now had not been in use. In [13] various schemes of DT realization were presented, and various problems of mathematical programming were simulated with the aid of electric circuits with DT and other unconventional elements.

DT has a primary and secondary winding. The instantaneous values of currents and voltages in these winding are related to each other in the same way as the complex values of harmonic currents and voltages in an ordinary transformer. Fig. 1 is a symbolic picture of DT. It contains two branches – the primary branch with current  $q'_1$  and voltage  $e_1$  and the secondary branch with current  $q'_2$  and voltage  $e_2$ . DT is described by the following equations:

$$q'_2 - t \cdot q'_1 = 0, \quad e_1 - t \cdot e_2 = 0,$$

где  $t$  - the turn ratio. From these equations it follows that  $q'_1 e_1 = -q'_2 e_2$ , which means that the sum of the output capacities of the primary and secondary branches of DT, is equal to zero. Therefore, the DT does not change the active and reactive capacity of a circuit, being a passive element. DT may be viewed as a node, where the currents with weight

coefficients are added up. Thus a full analogy occurs with the first Kirchhoff's law.

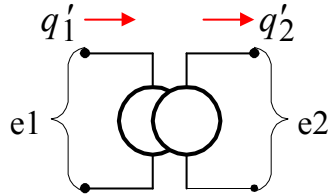

Fig. 1. A Symbolic picture of DT.

Let us consider now a special matrix of Dt – see Fig. 2. In this matrix we shall denote:

$j$  – number of row,

$k$  – number of column,

$J_k$  - the summary current of all windings, forming the  $k$ -column of this matrix,  $J = \{J_k\}$ ,

$\phi_k$  - the common voltage on the windings, forming the  $k$ -column of this matrix,  $\phi = \{\phi_k\}$ ,

$q'_j$  - the current of all windings, forming the  $j$ -row of this matrix,

$$q' = \{q'_j\}$$

$W_j$  - the summary voltage of all windings, forming the  $j$ -row of this matrix,  $W = \{W_j\}$

$t_{jk}$  - the turn ratios,  $T = \{t_{jk}\}$

Generally it is described by the following equations:

$$W_j = \sum_k t_{jk} \phi_k, \quad W = T \phi,$$

$$J_k = \sum_j t_{jk} q'_j, \quad J = T^T q',$$

$$J \phi = W q'.$$

Consequently, the DT does not change the active and reactive capacity of the circuit.

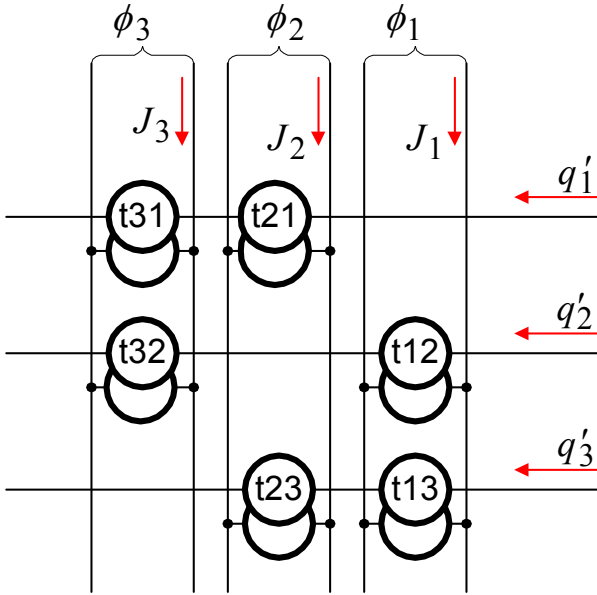

Fig. 2. Special matrix of DT.

The DT matrix is included into the electric circuit in such a way, that the rows of the matrix are parts of its branches. Then the second Kirchhoff's law takes the following form:

$$Sq + Mq'' + Rq' - E + N^T \varphi + T\phi = 0, \tag{1}$$

A circuit with “multi-winding” DT always may be transformed into a circuit with DT matrix.

**Example 1. “Multi-winding” DT.** Let us consider a circuit with “multi-winding” DT, shown on the Fig. A. The circuit shown on the Fig. B, containing the DT matrix, is equivalent to it. It becomes especially clear, if we draw it again in the form of Fig. C.

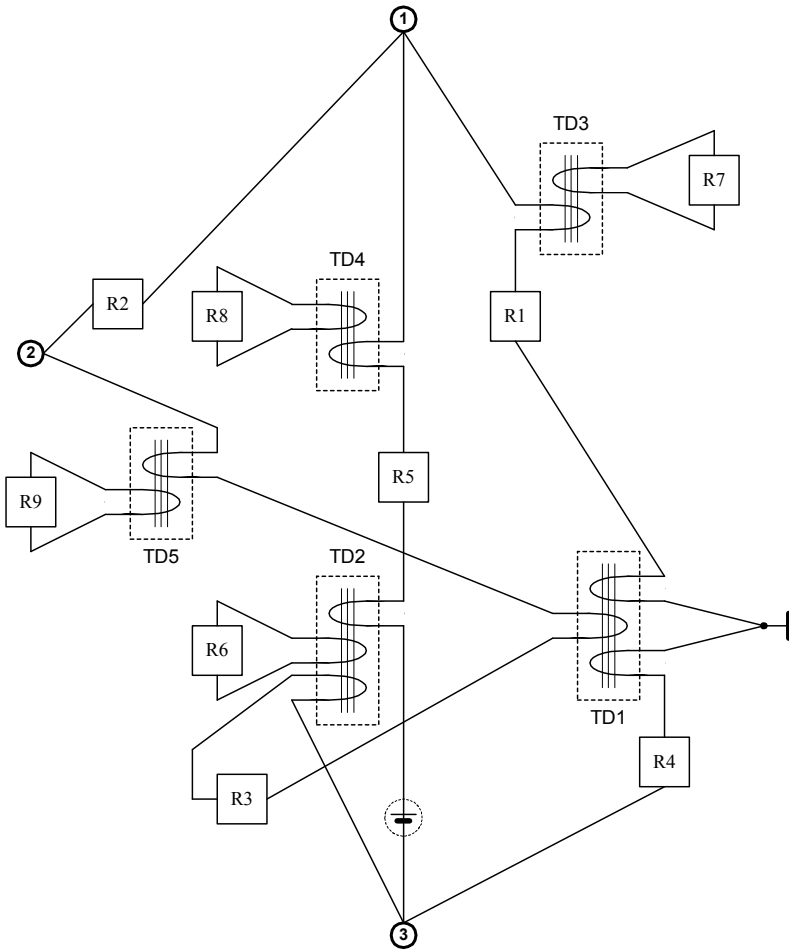

Fig. A.

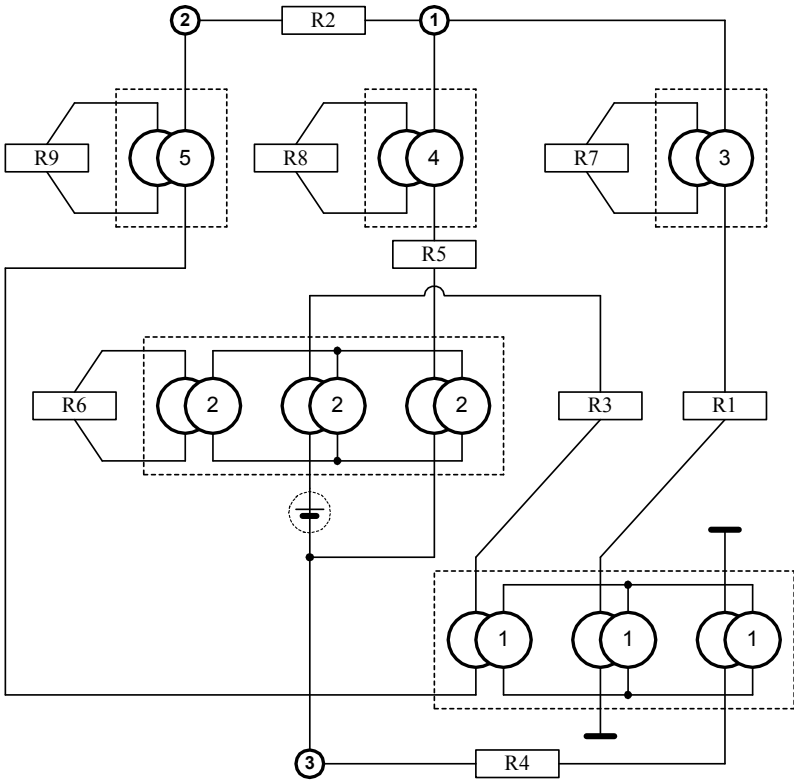

Fig. B.

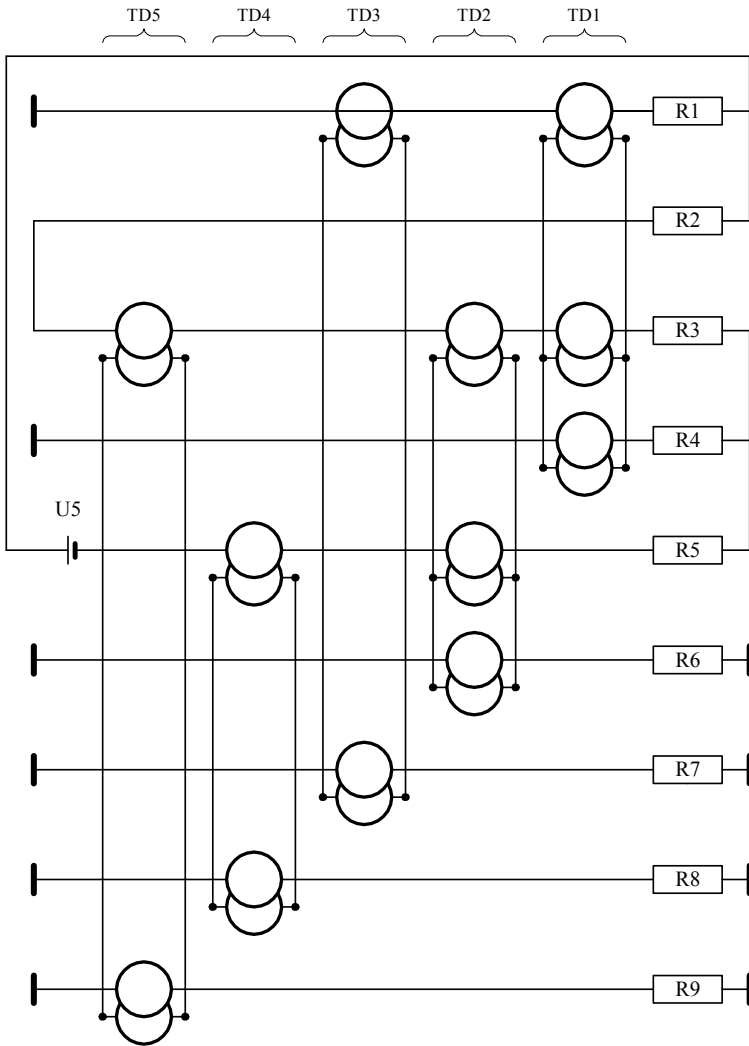

Fig. C.

In future we shall assume that in all ordinary nodes of the electric circuit the node resistances  $\rho$  and current sources  $H$  may be included, and in all transformer nodes the node resistances  $\rho$  and current sources  $P$  may be included. The currents running through resistances  $\rho$ , will be denoted as  $i$ ,  $m$  for ordinary nodes and transformer nodes, accordingly. Such circuits will be called *general-form* electric circuits.

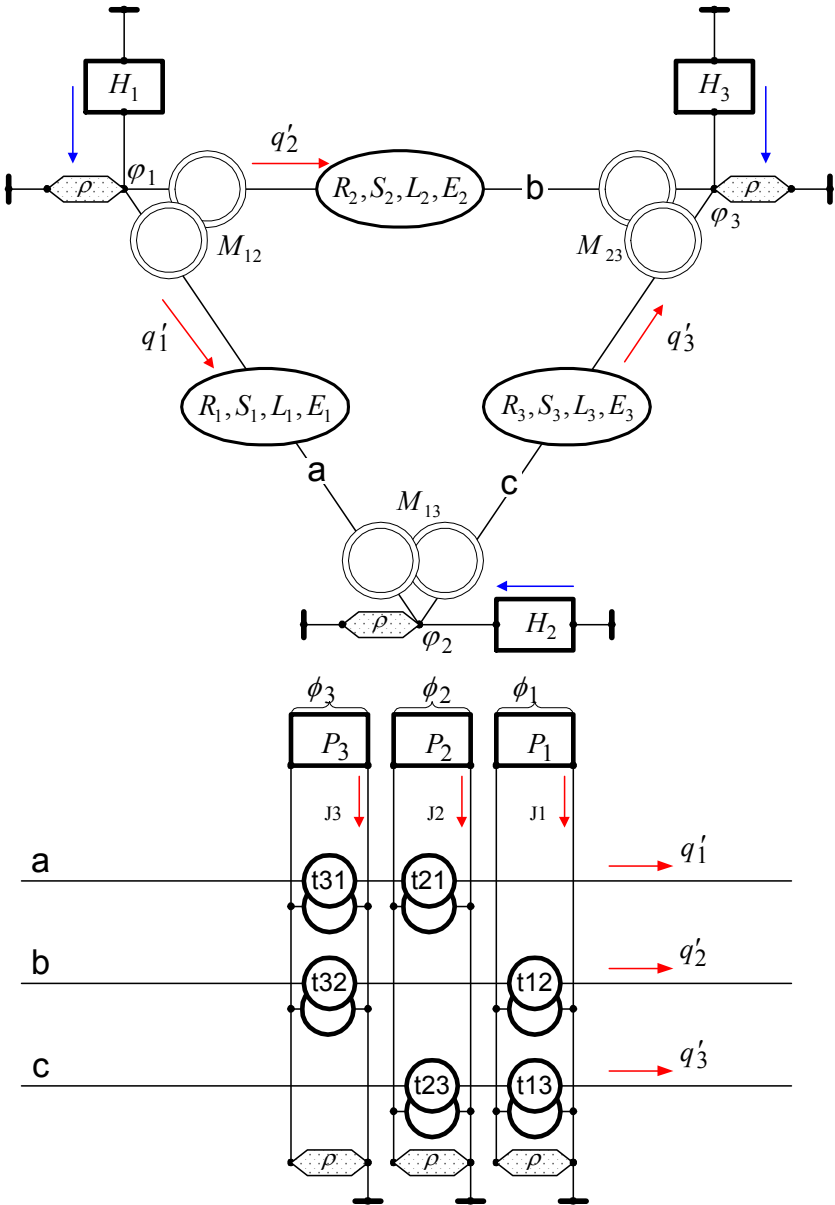

Fig. 3. An Example of General-form Electric Circuit



Fig. 3 shows an example of a general-form electric circuit, where node resistances and current sources are included in *all nodes*. There  $a$ ,  $b$ ,  $c$  denote the branches of the transformer matrix's rows and the gaps in ordinary branches, where the row branches are connected.

The first Kirchhoff's law takes the following form for ordinary and transformer nodes accordingly:

$$Nq' + H = i, \quad (2)$$

$$T^T q' + P = m. \quad (3)$$

Let us write these laws in the form of integral equations:

$$S\hat{g} + Mg' + Rg - E + N^T \varphi + T\phi = 0, \quad (4)$$

$$Ng + H = i, \quad (5)$$

$$T^T g + P = m. \quad (6)$$

there, as before,  $g = q'$ .

Let us turn now to the systems of equations (1)-(3) and (4)-(5). We shall consider the functionals, for which these systems are necessary conditions of optimum. These functionals take the following form.

For the systems of equations (1)-(3):

$$F(x, y, i, m, \mathcal{G}, \Psi, \theta, \xi) = \int_0^T f(x, y, i, m, \mathcal{G}, \Psi, \theta, \xi) dt, \quad (7)$$

where

$$f(.) = \left[ \begin{array}{l} x^T Sx' - y^T Sy - x'^T Mx + y'^T My + \\ + x^T Ry' - x'^T Ry - E^T (x - y) + \frac{\rho}{2} (i^T i + m^T m) + \\ + \mathcal{G}^T (2Nx + H - i) - \Psi^T (2Ny + H - i) - \\ - \theta^T (2T^T x' + P - m) - \xi^T (2T^T y' + P - m) \end{array} \right], \quad (8)$$

$$q = x + y, \quad \varphi = \mathcal{G}' + \Psi', \quad \phi = \theta' + \xi'. \quad (9)$$

For the systems of equations (4)-(5):

$$F(v, w, i, m, \mathcal{G}, \Psi, \theta, \xi) = \int_0^T f(v, w, i, m, \mathcal{G}, \Psi, \theta, \xi) dt, \quad (10)$$

where

$$f(\cdot) = \left[ \begin{array}{l} v^T S \hat{w} - \hat{v}^T S w + v^T M w' - v'^T M w + \\ + v^T R v - w^T R w - E^T (v - w) + \\ + \frac{\rho}{2} (i^T i + m^T m) + \\ + \mathcal{G}(2Nv + H + i) + \Psi(2Nw + H + i) - \\ - \theta (2T^T v + P + m) - \xi (2T^T w + P + m) \end{array} \right], \quad (11)$$

$$g = v + w, \quad \varphi = \mathcal{G} + \Psi, \quad \phi = \theta + \xi. \quad (12)$$

## 2. Unconditional Electric Circuit with Dennis Transformers

An electric circuit which has  $(1/\rho) \neq 0$ , will be in future called an **unconditional** circuit. An example of such circuit is shown in Fig. 3. The systems of equations (1)-(3) and (4)-(5) may be simplified with  $(1/\rho) \neq 0$ , for in this case all the potentials  $\varphi = i \cdot \rho$ ,  $\phi = m \cdot \rho$ , and may be excluded:

$$S q + M q' + R q' - E + \rho \cdot N^T (N q' + H) + \rho \cdot T \cdot (T^T q' + P) = 0,$$

$$S \hat{g} + M g' + R g - E + \rho \cdot N^T (N g + H) + \rho \cdot T \cdot (T^T g + P) = 0.$$

After similar terms reduction, we get (1.7) and (2.2), where

$$\bar{S} = S, \quad \bar{R} = (R + \rho \cdot N^T N + \rho \cdot T \cdot T^T)$$

$$\bar{M} = M, \quad \bar{E} = E - \rho \cdot (N^T H + T \cdot P) \quad (13)$$

So rge unconditional electric circuit with DT matrix is described by the equations (1.7) and (2.2). These equations are identical to the equations for RCL-circuits, and for the considered circuits there exist functionals, for which these equations serve as necessary conditions of optimum. These functionals have the following form:

- for the equation (1.7) - functionals (1.1), (1.2),
- for equation (2.2) - functionals (2.6), (2.7).

Notice that in these formulas the scalars  $S$ ,  $R$ ,  $L$ ,  $E$  are substituted by matrixes  $\bar{S}$ ,  $\bar{R}$ ,  $\bar{M}$ ,  $\bar{E}$ , defined according to (13).

Thus, the functionals for unconditional electric circuit have unconditional optimum. When  $\rho \rightarrow \infty$  an unconditional electric circuit approximates an ordinary electric circuit with the same parameters

(voltages and currents), but with  $\rho = \infty$ . In other words, the mode of electric circuit approaches the mode of the approximating unconditional electrical circuit when  $\rho \rightarrow \infty$ . It means that the calculation of electric circuit for sufficiently large  $\rho$  may be replaced by calculation of an approximating unconditional electric circuit. This method will be used hereinafter.

### 3. Electric Circuit with Integrating Transformers

*Integrating transformer* is described by the following equations:

$$q'_2 = t' \cdot q'_1 + t'' \cdot q''_1,$$

$$e_1 = t' \cdot e_2 + t'' \cdot e'_2,$$

where  $t'$ ,  $t''$  - the turn ratios. We shall in future denote such transformers by abbreviation IT. For IT the following equation is valid:

$$q'_1 t' e_1 + q''_1 t'' e_1 = q'_2 t' e_2 + q'_2 t'' e'_2.$$

For instance, if the currents and the voltages are sinusoidal functions, then

$$q'_1 e_1 (t' + j\omega \cdot t'') = q'_2 e_2 (t' + j\omega \cdot t'')$$

or

$$q'_1 e_1 = q'_2 e_2.$$

This means that IT does not change the active power of the circuit.

In sinusoidal current circuits IT is a *transformer with complex turn ratio*  $(t' + j\omega \cdot t'')$ . Notice that such transformers are widely used in *three-phase* power systems, where they are realized by a certain combination of windings connected to different phases. For one-phase sinusoidal currents circuits physical realization of IT does not exist (as, however, there is also no physical realization for DT). Evidently, with  $t'' = 0$  IT becomes DT.

Let us now consider a special matrix for IT, similar to the special matrix for DT, using the same notations. For the IT matrix the following equations are true:

$$W_j = \sum_k (t'_{jk} \phi_k + t''_{jk} \phi'_k), \quad W = T_1 \phi + T_2 \phi',$$

$$J_k = \sum_j (t'_{jk} q'_j + t''_{jk} q''_j), \quad J = T_1^T q' + T_2^T q'',$$

$$J\phi = Wq'.$$

Matrixes  $T_1$ ,  $T_2$  have a following forms:

$$T_1 = \begin{vmatrix} -1 & t'_{21} & t'_{31} & t'_{41} & \dots \\ t'_{12} & -1 & t'_{32} & t'_{42} & \dots \\ t'_{13} & t'_{23} & -1 & t'_{43} & \dots \\ t'_{14} & t'_{24} & t'_{34} & -1 & \dots \\ \dots & \dots & \dots & \dots & \dots \end{vmatrix}, \quad T_2 = \begin{vmatrix} 0 & t''_{21} & t''_{31} & t''_{41} & \dots \\ t''_{12} & 0 & t''_{32} & t''_{42} & \dots \\ t''_{13} & t''_{23} & 0 & t''_{43} & \dots \\ t''_{14} & t''_{24} & t''_{34} & 0 & \dots \\ \dots & \dots & \dots & \dots & \dots \end{vmatrix}$$

The second Kirchoff's law for branches of electric circuit with IT takes the following form:

$$Sq + Mg'' + Rq' - E + N^T \varphi + T_1 \phi + T_2 \phi' = 0, \quad (14)$$

The first Kirchoff's law in this case takes the following form for ordinary and transformer nodes, correspondingly:

$$Nq' + H = i, \quad (15)$$

$$T_1^T \cdot q' + T_2^T \cdot q'' + P = m. \quad (16)$$

Let us write these laws in the form of integral equations:

$$S\hat{g} + Mg' + Rg - E + N^T \varphi + T_1 \phi + T_2 \phi' = 0, \quad (17)$$

$$Ng + H = i, \quad (18)$$

$$T_1^T \cdot g + T_2 \cdot g' + P = m. \quad (19)$$

Here, as before,  $g = q'$ .

Let us turn now to the systems of equations (14)-(16) and (17)-(19). Consider the functionals for which these equations serve as the necessary conditions of optimum. These functionals look as follows.

For the equations (14)-(16):

$$F(x, y, i, m, \vartheta, \Psi, \theta, \xi) = \int_0^T f(x, y, i, m, \vartheta, \Psi, \theta, \xi) dt,$$

where

$$f(.) = \begin{bmatrix} x^T Sx' - y^T Sy - x'^T Mx + y'^T My + \\ + x^T Ry' - x'^T Ry - E^T (x - y) + \frac{\rho}{2} (i^T i + m^T m) + \\ + \vartheta^T (2Nx + H - i) - \Psi^T (2Ny + H - i) - \\ - \hat{\theta}^T (2T_1^T x' + 2T_2^T x'' + P - m) \\ - \hat{\xi}^T (2T_1^T y' + 2T_2^T y'' + P - m) \end{bmatrix},$$

$$q = x + y, \quad \varphi = \vartheta' + \Psi', \quad \phi = \theta' + \xi'.$$

For the equations (17)-(19):

$$F(v, w, i, m, \mathcal{G}, \Psi, \theta, \xi) = \int_0^T f(v, w, i, m, \mathcal{G}, \Psi, \theta, \xi) dt,$$

where

$$f(\cdot) = \left[ \begin{array}{l} v^T S \hat{w} - \hat{v}^T S w + v^T M w' - v'^T M w + \\ + v^T R v - w^T R w - E^T (v - w) + \\ + \frac{\rho}{2} (i^T i + m^T m) + \\ + \mathcal{G} (2Nv + H + i) + \Psi (2Nw + H + i) - \\ - \theta (2T_1^T v + 2T_2^T v' + P + m) \\ - \xi (2T_1^T w + 2T_2^T w' + P + m) \end{array} \right],$$

$$g = v + w, \quad \varphi = \mathcal{G} + \Psi, \quad \phi = \theta + \xi.$$

The systems of equations (14)-(16) and (17)-(19) for unconditional electric circuit may be simplified if  $(1/\rho) \neq 0$ , as in this case the potentials  $\varphi = i \cdot \rho$ ,  $\phi = m \cdot \rho$ , and so they may be excluded:

$$\begin{aligned} S q + M q'' + R q' - E + \rho \cdot N^T (N q' + H) + \\ + \rho \cdot T_1 (T_1^T q' + T_2^T q'' + P) + \rho \cdot T_2 (T_1^T q'' + T_2^T q''' + P') = 0, \\ S \hat{g} + M g' + R g - E + \rho \cdot N^T (N g + H) + \\ + \rho \cdot T_1 (T_1^T g + T_2^T g' + P) + \rho \cdot T_2 (T_1^T g' + T_2^T g'' + P') = 0. \end{aligned}$$

In sinusoidal current circuits  $q''' = -\omega^2 q'$ ,  $g = -\omega^2 g''$ . Then from last two equations after appropriate cancellations we shall get (1.7) and (2.2), where

$$\begin{aligned} \bar{S} &= S, \\ \bar{R} &= \left( R + \rho \cdot N^T N + \rho \cdot T_1 T_1^T - \omega^2 \rho \cdot T_2 T_2^T \right) \\ \bar{M} &= \left( M + \rho \cdot T_2 T_1^T + \rho \cdot T_1 T_2^T \right) \\ \bar{E} &= \left( E - \rho \cdot (N^T H + T_1 P + T_2 P') \right) \end{aligned} \quad (20)$$

The further arguments are fully similar to those used for the circuits with DT. The only difference is that instead of the formula (13) the formula (20) is used.

The further arguments are fully similar to those used for the circuits with DT. The difference is only in using formula (20) instead of formula (13). In this general case unconditional circuit differs from a real circuit by the fact, that in the transformer nodes of a real circuit the node currents are equal to zero, and in an unconditional circuit these currents are nonzero – see (15) and (16). In future we shall call these currents *methodic error of the first Kirchhoff's law* or *residual* in the equations (15) and (16). This error is the less, the greater is  $\rho$ . The consequence of this is deviation of the vector  $q$  in unconditional circuit from vector  $q$  in real circuit, which is equivalent to a certain *residual* in equation (14) for real circuit.

# Chapter 4. Generalized Functional

---

## 1. Generalized Functional for Unconditional Electric Circuit

From the abovesaid it follows that the principle of extremum of functional (1.1, 1.2) from split function of charges  $x$  and  $y$  leads to such distribution of charges which maximizes the functional as the function of  $x$  and minimizes it as a function of  $y$ . The sum of the optimal values of  $x$  and  $y$  is equal to the observed function of charges  $q$ . Similarly, the principle of extremum of functional (2.6, 2.7) from split function of currents  $v$  and  $w$  leads to such distribution of currents which maximizes the functional as the function of  $v$  and minimizes it as a function of  $w$ . The sum of the optimal values of  $v$  and  $w$  is equal to the observed function of currents  $q$ . Thus, in an unconditional electric circuit there is an objectively established unconditional extremum of a charge functional (1.1, 1.2) and unconditional extremum of a current functional (2.6, 2.7). The result of this optimization are the equations of the second Kirchhoff's law for the charges (1.7) and the currents (2.2) accordingly. It is assumed that in these formulas the scalars  $S, R, L, E$  are changed to matrixes  $\bar{S}, \bar{R}, \bar{M}, \bar{E}$ , calculated according to (3.13). For the sake of clearness let us combine these formulas in the Table 1.

Both functionals (1.1) and (2.6) are optimized *simultaneously*. It means that we are seeking such functions  $g = q'$ , whose optimal values provide an optimum to these functional *simultaneously*. This, in its turn, means that every deviation of the functions  $g = q'$  from optimal value (even towards improvement) leads to the result that the value of another functional is adversely affected.

Table 1.

| Variables | Formula's number | Formula  |
|-----------|------------------|--|
| charges   | 1.1              | $F(x, y) = \int_0^T f(x, y) dt$  |
|           | 1.2              | $f(x, y) = \left\{ \begin{array}{l} S(x^2 - y^2) - L(x'^2 - y'^2) \\ + R(xy' - x'y) - E(x - y) \end{array} \right\}$         |
|           | 1.7              | $Sq + Lq'' + Rq' - E = 0$  |
|           | 1.8              | $q = x + y$  |
| currents  | 2.6              | $F(x, y) = \int_0^T f(v, w) dt$  |
|           | 2.7              | $f(v, w) = \left\{ \begin{array}{l} S(v\hat{w} - \hat{v}w) + L(vw' - v'w) \\ + R(v^2 - w^2) - E(v - w) \end{array} \right\}$ |
|           | 2.2              | $S\hat{g} + Lg' + Rg - E = 0$  |
|           | 2.5              | $g = v + w$  |

Below we shall denote

$h(t)$  – function of time  $t$ ,

$\mu$  - differentiation operator,

$\bar{h}(\mu)$  - image of the function  $h(t)$ .

The simultaneity of both functionals optimization from procedural point of view means the following:

1) Each step begins with equal values of the functions  $g = q'$ . The gradients of both functionals coincide and are equal to

$$p = \bar{S}q + \bar{M}q'' + \bar{R}q' - \bar{E}. \quad (1)$$

2) The steps by the functionals  $a_1, a_2$ , should ensure the equality of the new values of the functions; for which purpose the condition  $\Delta q' = \Delta g$  or  $\mu a_1 p = a_2 p$ , should hold, or

$$\mu a_1 = a_2. \quad (2)$$

3) The variables  $g = q'$  should be smaller by half than the values they take when performing separate optimization. Then their sum when optimizing the generalized functional will be equal to the sought function. From physical considerations it is clear that all currents in electric circuit will become smaller by half if all the generated voltages were cut by half and all the currents from all the sources were cut by half.



It follows that to determine the size of the step, one should calculate the values  $A'_1, A'_2$  depending on  $\bar{S}, \bar{R}, \bar{M}, \bar{E}/2$ , and not the values  $A_1, A_2$ , which are calculated depending on  $\bar{S}, \bar{R}, \bar{M}, \bar{E}$ .

4) Thus, if in separate optimization the steps were determined from

$$\frac{\partial F(q_n)}{\partial a_1} = A_1 + B_1 a_1 = 0, \quad \frac{\partial F(g_n)}{\partial a_2} = A_2 + B_2 a_2 = 0, \quad (3)$$

in simultaneous optimization the steps, considering (2), should be calculated from the condition

$$\frac{\partial F(q_n, g_n)}{\partial a_1} = A'_1 + B_1 a_1 + A'_2 + B_2 \mu a_1 = 0. \quad (4)$$

Hence it follows

$$a_1 = \frac{-(A'_1 + A'_2)}{B_1 + \mu B_2} \quad (5)$$

or

$$a_2 = \frac{-\mu(A'_1 + A'_2)}{B_1 + \mu B_2} \quad (6)$$

5) As follows from (1.13a) and (2.14a), in the case of simultaneous optimization the functions' increments should be found by the formula

$$\Delta q = -2a_1 p, \quad \Delta g = -2a_2 p. \quad (9)$$

Thus, from (1.9), (6) and (9) we find

$$\overline{\Delta q'} = \frac{2\mu \cdot (A'_1 + A'_2)}{B_1 + \mu \cdot B_2} \bar{p}, \quad (10)$$

So, in simultaneous optimization in every iteration

- The gradient  $p$  is calculated from (1.7) with a given function  $q$  or, which is the same, - from (2.14) with a given function  $g = q'$ ; this gradient is common for the two functionals, and is determined from (1).
- The main coefficients  $A_1, B_1, A_2, B_2$  are calculated from the formulas (1.12), (1.11), (2.13), (2.12) accordingly; in these formulas  $\bar{E}$  should be substituted by  $\bar{E}/2$ .
- The increment of the sought current function is determined from the formula (10).

Let us write the formulas for the main coefficients of the formula (10):

$$A'_1 = \int_0^T \left[ \left( \begin{array}{c} -q^T \bar{S}p + q^T \bar{M}p' + \\ \left( q^T \bar{R}p' - q'^T \bar{R}p \right) \end{array} \right) + \frac{\bar{E}p}{2} \right] dt, \quad (11a)$$

$$B_1 = 2 \int_0^T \left( p^T \bar{S}p - p'^T \bar{M}p' \right) dt, \quad (11b)$$

$$A'_2 = \int_0^T \left[ \left( \begin{array}{c} p^T \bar{S}q + p^T \bar{M}q'' \\ \left( -\hat{p}^T \bar{S}q' - p'^T \bar{M}q' \right) \end{array} \right) / 2 - p^T \bar{R}q' \right] + \frac{\bar{E}p}{2} dt \quad (11n)$$

$$B_2 = 2 \int_0^T p^T \bar{R}p dt. \quad (11m)$$

Generally for the calculations according to the formula (10) it is necessary to:

1. turn from the function  $p$  to its image  $\bar{p}$ ,
2. using the formula (10) find the image  $\overline{\Delta q'}$ ,
3. turn from the image  $\overline{\Delta q'}$  to function  $\Delta q'$ .

From (11a) and (11n) it follows that the value (11r)

$$A = (A'_1 + A'_2) \quad (11r)$$

from the formula (10), may be calculated by the formula

$$A = \int_0^T \left[ -\frac{1}{2} \left( p^T \bar{S}q + \hat{p}^T \bar{S}q' \right) + \left( q^T \bar{R}p' + q'^T \bar{R}p \right) + \bar{E}p \right] dt \quad (11s)$$

From (1.5, 2.8) it follows that for the existence of the generalized functional's optimum it is sufficient for the matrixes  $\bar{M}$ ,  $\bar{R}$  to be positive semi-definite.

Let us again consider the functional

$$F(q) = \int_0^T \left\{ q^T \bar{S}q - q'^T \bar{M}q' + q^T \bar{R}q' - 2q^T \bar{E} \right\} dt \quad (12)$$

with the integrand vector-function  $q$ . The variation of this functional has, evidently, the form

$$p = \bar{S}q + \bar{M}q'' - \bar{E}.$$

We, however, shall calculate the variation using the formula

$$p = \bar{S}q + \bar{M}q'' + \bar{R}q' - \bar{E} \quad (13)$$

and shall call it quasivariation of functional (12). Clearly, all the components of the formulas (10, 11) depend only on quasivariation and on its components. The found results may be formulated in the form of the following theorem.

**Theorem 1.** Let us consider functional (12) with positive semi-definite matrices  $\bar{M}$ ,  $\bar{R}$  and its quasivariation (13). The movement in this functional in the direction (10, 11) is equivalent to the global saddle points of the two secondary functionals with integrands

$$f(x, y) = \begin{cases} x^T \bar{S}x - y^T \bar{S}y - x'^T \bar{M}x' + y'^T \bar{M}y' \\ + x^T \bar{R}y' - x'^T \bar{R}y - \bar{E}^T (x - y) \end{cases}, \quad (14)$$

$$f(v, w) = \begin{cases} v^T \bar{S}\hat{w} - \hat{v}^T \bar{S}w - v^T \bar{M}w + w^T \bar{M}v \\ + v^T \bar{R}v - w^T \bar{R}w - \bar{E}^T (v - w) \end{cases}.$$

The stationary values of the functions  $q, x, y, v, w$  satisfy the conditions

$$x'_o = y'_o = v_o = w_o, \quad q'_o = x'_o + y'_o + v_o + w_o,$$

and the condition of stationary value is

$$\bar{S}q + \bar{M}q'' + \bar{R}q' - \bar{E} = 0. \quad (15)$$

**Corollary 1.** Let us consider the functional (14) and the functional (12), which is secondary with respect to the former, and also the quasivariation of the functional (13). The necessary conditions of the existence of saddle line of the functional (14) is that the quasivariation (13) is equal to zero, where  $q = x + y$ .

## 2. Sufficient Conditions of Existence for Generalized Functional's Extremum

Let us consider more closely the sufficient conditions of extremum for the functional (1.1) with integrand (1.2). The arguments of this function are vector functions  $x, y$ . In section 1 it was shown that for an electric circuit the matrix  $M$  is *positive* definite. This matrix appears in the functional with negative sign. Therefore, the extremum for functional (1.1, 1.2) is *a global weak maximum* with respect to the function  $x$  and *– a global weak minimum* with respect to the function  $y$ . If the matrix  $M$  is *negative* definite, then the extremum of the functional (1.1, 1.2) is *a global weak minimum* with respect to the function  $x$  and *– a global weak maximum* with respect to the function  $y$ . Thus, in the general case the extremum of functional (1.1, 1.2) exists if the matrix  $M$  is *of fixed sign*.

If  $M=0$ , then to define the sufficient conditions of *strong* optimum it the matrix  $S$  must be considered. For an electrical circuit the matrix  $S$  is *positive* definite. This matrix appears in the functional with a positive sign. Therefore, the extremum of the functional (1.1, 1.2) is a *global strong maximum* with respect to the function  $x$  and – a *global strong minimum* with respect to the function  $y$ . If the matrix  $S$  is *negative definite*, then the extremum for the functional (1.1, 1.2) is a *global strong minimum* with respect to the function  $x$  and – a *global strong maximum* with respect to the function  $y$ . Thus, in the general case the extremum of functional (1.1, 1.2) exists if the matrix  $S$  is of *fixed sign*.

Let us now consider more closely the sufficient conditions of extremum for the functional (2.6) with integrand (2.7). The arguments of this function are vector functions  $v, w$ . In section 1 it was shown that for an electric circuit the matrix  $R$  is *positive* definite. This matrix appears in the functional with positive sign. Therefore, the extremum for functional (2.6, 2.7) is a *global weak maximum* with respect to the function  $v$  and – a *global weak minimum* with respect to the function  $w$ . If the matrix  $R$  is *negative* definite, then the extremum of the functional (2.6, 2.7) is a *global weak minimum* with respect to the function  $v$  and – a *global weak maximum* with respect to the function  $w$ . Thus, in the general case the extremum of functional (2.6, 2.7) exists if the matrix  $R$  is of *fixed sign*.

For a generalized functional (when the functionals (1.1, 1.2) and (2.6, 2.7) are being optimized simultaneously) the sufficient conditions of extremum existence for the functionals (1.1, 1.2) и (2.6, 2.7) should be fulfilled. The table 2 shows the sufficient conditions in dependence of the sort of matrices  $M, S, R$ .

Table 2.

| № | Sufficient condition determining | $R$                     | $S$                     | $M$           |
|---|----------------------------------|-------------------------|-------------------------|---------------|
| 1 | Strong optimum                   | Of fixed sign or absent | Of fixed sign           | Absent        |
| 2 | Strong optimum                   | Of fixed sign           | Of fixed sign or absent | Absent        |
| 3 | Weak optimum                     | Of fixed sign           | No difference           | Of fixed sign |

### 3. Generalized Functional for general-form electric circuit

From the above discussion it follows that in an electric circuit there is an objectively established extremum of a charge functional (1.1, 1.24) and an extremum of a current functional (2.6, 2.22) under the constraints (1.14) или (2.15). We assume there that in these formulas the scalars  $S, R, L, E$  are changed to the matrixes  $\bar{S}, \bar{R}, \bar{M}, \bar{E}$ , calculated by (3.13). For the sake of clearness let us combine all these formulas in the Table 3.

Table 3.

| Vari-ables | Formula's number | Formula  |
|------------|------------------|--|
| charges    | 1.1              | $F(x, y) = \int_0^T f(x, y) dt$  |
|            | 1.24             | $f(x, y) = \left\{ \begin{array}{l} x^T Sx - y^T Sy - x'^T Mx' + y'^T My' + \\ + x^T Ry' - x'^T Ry - E^T (x - y) + \\ + \mathcal{G}^T (2Nx' + H) + \Psi^T (2Ny' + H) \end{array} \right\}$ |
|            | 1.14             | $Sq + Mq'' + Rq' - E + N^T \varphi = 0$  |
|            | 1.15             | $Nq' + H = 0$  |
|            | 1.8, 1.19        | $q = x + y, \varphi = \mathcal{G}' + \Psi'$  |
| currents   | 2.6              | $F(x, y) = \int_0^T f(v, w) dt$  |
|            | 2.22             | $f(v, w) = \left[ \begin{array}{l} v^T S\hat{w} - \hat{v}^T Sw + v^T Lw' - v''^T Lw + \\ + v^T Rv - w^T Rv - E^T (v - w) + \\ + \mathcal{G}(2Nv + H) + \Psi(2Nw + H) \end{array} \right]$  |
|            | 2.15             | $S\hat{g} + Mg' + Rg - E + N^T \varphi = 0$  |
|            | 2.16             | $Ng + H = 0$   |
|            | 2.5, 2.17        | $g = v + w, \varphi = \mathcal{G} + \Psi$  |

# Chapter 5. Electric Circuit Computing Algorithms

---

## 1. General Algorithm

The results obtained in Chapter 4 may be used for computing electric circuits. In the general case the computations proceed according to the following gradient search algorithm.

### Algorithm 1. The general case

1. set  $q = 0$ ,  $q' = 0$ ,  $q'' = 0$ .
2. compute *the gradient*  $p$  by the formula (4.0);
3. determine the norm  $\|p\|$  of gradient  $p$ ;
4. if  $\|p\| < \varepsilon$  the computation is finished with the given value  $q$ ;
5. compute the main coefficients by the formula (4.11);
6. determine the image  $\bar{p}$  of the original  $p$ ;
7. determine the image of *current increment* by the formula (4.10);
8. determine the original of current increment  $\Delta q'$  to the image  $\bar{\Delta q'}$ ;
9. compute the new value of current  $q' \leftarrow q' + \Delta q'$ ;
10. repeat points 2-9.

For computing linear alternating current electric circuits by this algorithm one may, naturally, use a general-purpose computer. However for speeding up the computations it is advisable to use a matrix processor, for the algorithm deals mostly with matrixes in its operations. At the same time it is significant that matrixes conversion does not appear in the algorithm, which reduces the computing time and memory usage.

In some particular cases the computing formulas of the main coefficients  $A'_1, B_1, A'_2, B_2$  and current increment  $\Delta q'$  may be simplified. Below we shall consider most common types of functions and computation modifications for these functions.

## 2. System of Linear Differential Equations

**2.1. Method 1.** The above stated results may be interpreted as a method of solution of a system of second order differential equations of the form (4.15) of the variable  $q(t)$ . The system we are to solve must have the form

$$ax'' + bx' + cx + d = 0, \quad (1)$$

where

$x$  – vector of unknowns,

$a, b, c$  – given positive definite matrix square matrix,

$d$  – given vector.

Assuming that  $q = x$ ,  $\bar{M} = a$ ,  $\bar{R} = b$ ,  $\bar{S} = c$ ,  $\bar{E} = -d$ , from (3.20) we can find the parameters of electric circuit, which simulates the given system of second order differential equations.

In particular, an electric circuit may be simulating a system of first order general-form differential equations

$$ax' + bx + d = 0. \quad (2)$$

Assuming that  $q' = x$ ,  $\bar{M} = a$ ,  $\bar{R} = b$ ,  $\bar{S} = 0$ ,  $\bar{E} = -d$ , from (3.20) we can find the parameters of electric circuit, which simulates a given system of first order differential equations.

From section 4.4 it follows that the solution of system (4.15) is equivalent to the minimization of functionals (16) and (17) with constraint (4.15). Hence, the solution of system (1) is equivalent to the minimization of functionals

$$F_1(x) = \int_0^T (x^T c \cdot x - x'^T a \cdot x' + 2d^T x) dt, \quad (3)$$

$$F_2(x) = \int_0^T (x'^T b \cdot x' + 2d^T x') dt \quad (4)$$

with constraint (1). For a well-determined system (1) the optimization is practically absent, as there is only one solution. We shall consider now certain transformations of ill-determined systems, which will give a natural mathematical interpretation to the criteria (3) and (4).

**Underdetermined system.** In such system the number of equations is less than the number of variables. In this case system (1) may be complemented by equation

$$k^T x'' + n^T x' + m^T x = 0, \quad (5)$$

where  $k, n, m$  – vectors of given weight coefficients. Then system (1) is transformed into a system of the following form

$$\begin{vmatrix} a \\ k \end{vmatrix} x'' + \begin{vmatrix} b \\ n \end{vmatrix} x' + \begin{vmatrix} c \\ m \end{vmatrix} x + \begin{vmatrix} d \\ 0 \end{vmatrix} = 0, \quad (6)$$

And functionals (3) and (4) take the form:

$$F_1(x) = \int_0^T \left( x^T c \cdot x - x'^T a \cdot x' + x^T m \cdot x - x'^T k \cdot x' + 2d^T x \right) dt,$$

$$F_2(x) = \int_0^T \left( x'^T b \cdot x' + x'^T n \cdot x' + 2d^T x' \right) dt.$$

If the coefficients  $k$ ,  $n$ ,  $m$  are relatively large, then the latter functionals are transformed into

$$F_1(x) = \int_0^T \left( x^T m \cdot x - x'^T k \cdot x' \right) dt, \quad (7)$$

$$F_2(x) = \int_0^T \left( x'^T n \cdot x' \right) dt. \quad (8)$$

These functionals correspond to minimization of a weighted sum of squared variables and their derivatives. Notice that the matrices  $n$ ,  $m$

should complement the matrices  $a$ ,  $b$  to square matrices  $\begin{vmatrix} a \\ m \end{vmatrix}$ ,  $\begin{vmatrix} b \\ n \end{vmatrix}$ .

**Overdetermined system.** In such system the number of equations is larger than the number of variables. In this case system (1) may be transformed to the form

$$\begin{vmatrix} a \\ k \end{vmatrix} \begin{vmatrix} 0 \\ x'' \\ y'' \end{vmatrix} + \begin{vmatrix} b \\ n \end{vmatrix} \begin{vmatrix} 0 \\ x' \\ y' \end{vmatrix} + \begin{vmatrix} c \\ m \end{vmatrix} \begin{vmatrix} x \\ y \end{vmatrix} + d = 0, \quad (9)$$

where  $y$  – vector of additional variables,  $k$ ,  $n$ ,  $m$  – matrices of given weight coefficients of the additional variables. Then the functionals (3) and (4) will take the following form:

$$F_1(x) = \int_0^T \left( x^T c \cdot x - x'^T a \cdot x' + y^T m \cdot y - y'^T k \cdot y' + 2d^T x \right) dt,$$

$$F_2(x) = \int_0^T \left( x'^T b \cdot x' + y'^T n \cdot y' + 2d^T x' \right) dt.$$

If the weight coefficients  $k$ ,  $n$ ,  $m$  are relatively large, the latter functionals will have the form

$$F_1(x) = \int_0^T \left( y^T m \cdot y - y'^T k \cdot y' \right) dt, \quad (10)$$

$$F_2(x) = \int_0^T \left( y'^T n \cdot y' \right) dt. \quad (11)$$

These functionals correspond to minimization of weighted sum of squared residuals of the variables and their derivatives. Notice, that



matrices  $n$ ,  $m$  should complement matrices  $a$ ,  $b$  to square matrices

$$\left| \begin{array}{c} a \\ 0 \\ m \end{array} \right|, \left| \begin{array}{c} b \\ 0 \\ n \end{array} \right|.$$

**2.2. Method 2.** Let us consider functionals (1.1, 1.2), (2.6, 2.7), where scalars  $S$ ,  $R$ ,  $L$ ,  $E$  are replaced by matrices  $S$ ,  $R$ ,  $M$ ,  $E$ . Optimization of these functionals under constraints

$$Nq' + H = 0, \tag{12}$$

$$T'^T \cdot q' + T''^T \cdot q + P = 0 \tag{13}$$

(see (3.15, 3.16) or (3.18, 3.19)) is equivalent (as was shown above) to *unconditional* optimization of the same functionals, where scalars  $S$ ,  $R$ ,  $L$ ,  $E$  are replaced by matrices  $\bar{S}$ ,  $\bar{R}$ ,  $\bar{M}$ ,  $\bar{E}$ , defined by (3.20), if  $\rho \rightarrow \infty$ .

We shall consider now a certain special case, when

$$E = 0, R = 0, S = 0, M = 0, N = 0,$$

and shall denote  $x = q$ ,  $b = T'^T$ ,  $a = T''^T$ ,  $c = -P$ . Then the equation (13) transforms to equation

$$a \cdot x + b \cdot x' = c \tag{14}$$

And from (3.20) we shall get:

$$\bar{S} = -\rho \cdot a^T b, \bar{R} = -\rho (aa^T + bb^T) \tag{15}$$

$$\bar{M} = -\rho \cdot a^T b, \bar{E} = -\rho \cdot (bc + a\hat{c})$$

Hence, the equation (14) is replaced by the equation

$$a^T b(x + x') + (aa^T + bb^T)' + (bc + a\hat{c}) = 0. \tag{17}$$

Simultaneously with the solution of this equation the functionals (4.16) and (4.17) are being minimized. The latter functionals in this case take the form

$$F_1(x) = \int_0^T \left( x^T a^T b x + x'^T a^T b x' + 2(bc + a\hat{c})^T x \right) dt, \tag{18}$$

$$F_2(x) = \int_0^T \left( x'^T (aa^T + bb^T)' + 2(bc + a\hat{c})^T x' \right) dt, \tag{19}$$

If the system of equations (14) is well-determined, then this system and the system (17) have one solution. Let us now deal with the cases when the system of equations (14) is ill-determined.

**Underdetermined system.** In such system the number of equations is less than the number of variables, and there exist multiple solutions. However, due to the fact that in this method the functionals (18) and (19)

are being optimized, a sole solution is being chosen. This solution minimizes the quadratic forms (18) and (19).

**Overdetermined system.** In such system the number of equations is larger than the number of variables, and system (14) has no solution. However, due to the fact, that in this method the solution of system (14) is replaced by solution of system (17), a certain solution is determined which gives minimum to functionals (18) and (19). This solution satisfies the equation (14) with a certain *residual* – see section 3.3. As it is evident from (18) and (19), this residual is such, that the named inexact solution minimizes the functionals (18) и (19).

### 3. Interoperable Functions

Let us consider the functions  $f_1(t)$ ,  $f_2(t)$  of a certain form, for which the following formulas are valid:

$$\int_0^T f_1(t) \cdot f_2'(t) \cdot dt = \mu \int_0^T f_1(t) \cdot f_2(t) \cdot dt, \tag{1}$$

$$\int_0^T f_1'(t) \cdot f_2'(t) \cdot dt = \mu^2 \int_0^T f_1(t) \cdot f_2(t) \cdot dt, \tag{2}$$

$$\int_0^T f_1''(t) \cdot f_2(t) \cdot dt = \mu^2 \int_0^T f_1(t) \cdot f_2(t) \cdot dt, \tag{3}$$

$$\int_0^T f_1(t) \cdot f_2'(t) \cdot dt = \int_0^T f_1'(t) \cdot f_2(t) \cdot dt, \tag{4}$$

$$\int_0^T \hat{f}_1(t) \cdot f_2'(t) \cdot dt = \int_0^T f_1(t) \cdot f_2(t) \cdot dt. \tag{5}$$

For the sake of simplicity we shall call such functions *interoperable*. It is easy to see that among such functions are first of all exponential functions  $f(t) = u \cdot e^{\alpha \cdot t}$ , where  $\alpha$  – a real or a complex number. To this class of functions belong also sine and cosine, hyperbolic sine and cosine and sums of the above named functions. Besides, to this class belong the functions  $f(t) = e^{\alpha t} \text{Sin}(\beta t)$ , where  $\beta$  – a real or a complex number which follows from the relation:

$$f(t) = e^{\alpha t} \text{Sin}(\beta t) = \frac{e^{\alpha + j\beta} - e^{\alpha - j\beta}}{2j}. \tag{6}$$

Below it will be shown that the functions of current appearing in the electric circuit after the application of step voltage, are also interoperable.

For interoperable functions the formulas (4.11) are simplified and assume the following form

$$A'_1 = \int_0^T \left[ -q^T \bar{S}p - q'^T \bar{M}p' + \frac{\bar{E}p}{2} \right] dt,$$

$$B_1 = 2 \int_0^T \left( p^T \bar{S}p + p'^T \bar{M}p' \right) dt,$$

$$A'_2 = \int_0^T \left[ -p^T \bar{R}q' + \frac{\bar{E}p}{2} \right] dt,$$

$$B_2 = 2 \int_0^T p^T \bar{R}p dt$$

or

$$A'_1 + A'_2 = \int_0^T \left[ q^T \bar{S}p + \bar{E}p \right] dt - \mu^2 \int_0^T \left[ q^T \bar{M}p \right] dt - \mu \int_0^T \left[ p^T \bar{R}q \right] dt,$$

$$B_1 = 2 \left( \int_0^T \left( p^T \bar{S}p \right) dt + \mu^2 \int_0^T \left( p^T \bar{M}p \right) dt \right),$$

$$B_2 = 2 \int_0^T p^T \bar{R}p dt.$$

Formula (4.10) then assumes the following form:

$$\overline{\Delta q'} = \frac{-\int_0^T q^T \bar{S}p dt - \mu^2 \int_0^T q^T \bar{M}p dt - \mu \int_0^T q^T \bar{R}p dt + \int_0^T \bar{E}p dt}{\int_0^T p^T \bar{S}p dt + \mu^2 \int_0^T p^T \bar{M}p dt + \mu \int_0^T p^T \bar{R}p dt} \mu \cdot \bar{p}$$

or

$$\overline{\Delta q'} = \frac{-\int_0^T \left( q^T (\bar{S} + \mu^2 \bar{M} + \mu \bar{R}) - \bar{E} \right) p dt}{\int_0^T p^T (\bar{S} + \mu^2 \bar{M} + \mu \bar{R}) p dt} \mu \cdot \bar{p}.$$

Taking into account the formula for gradient  $p$  finally we get

$$\overline{\Delta q'} = \frac{-\int_0^T p^T p dt}{\int_0^T p^T (\bar{S} + \mu^2 \bar{M} + \mu \bar{R}) p dt} \mu \cdot \bar{p}. \quad (7)$$

In particular, for  $\bar{S} = 0$ ,  $\bar{M} = 0$  we have:

$$\Delta q' = - \left( \int_0^T p^T p dt / \int_0^T p^T \bar{R}p dt \right) \cdot p. \quad (7a)$$

It is significant that the functions  $q$  and  $p$  do not change their form when passing from iteration to iteration.

## 4. Sinusoidal Functions

In the case when the voltages and currents of the sources are sinusoidal functions with circular frequency  $\omega$ , algorithm 1 is simplified. In this case the functions of time are substituted by complex numbers (denoted by the same symbols). The definite integral will be substituted by scalar product:

$$\int_0^T \left( a^T D \cdot b \right) dt = \frac{\pi}{\omega} a D \otimes b,$$

Here the upper bound in the integral is  $T = 2\pi/\omega$ , and symbol  $\otimes$  denotes operation of component-wise scalar multiplication of complex vectors and summation of these products. The result of such operation is a real number.

In this case we have:

$$\int_0^T q'^T D p' dt = \int_0^T q''^T D p dt = -\omega^2 \frac{\pi}{\omega} q D \otimes p, \quad (1)$$

$$\int_0^T q'^T D p dt = \int_0^T q^T D p' dt = j\omega \frac{\pi}{\omega} q D \otimes p, \quad (2)$$

$$\int_0^T \hat{p}^T D q' dt = \int_0^T q^T D p dt = \frac{\pi}{\omega} q D \otimes p,$$

$$\int_0^T \left[ p'^T \bar{R} q - p^T \bar{R} q' \right] dt = 0,$$

$$\int_0^T \left( p^T \bar{S} q - p^T \bar{M} q'' + \hat{p}^T \bar{S} q' + p'^T \bar{M} q' \right) dt = 0.$$

Since the formula (4.10) includes a ratio of integrals, the factor  $\pi/\omega$  may be discarded, and all the integrals will be substituted by scalar products.

From (4.1) we find

$$p = \left( \bar{S} - \omega^2 \bar{M} + j\omega \bar{R} \right) q - \bar{E}$$

or

$$p = \left( \frac{-j\bar{X}}{\omega} + \bar{R} \right) \cdot g - \bar{E}, \quad (3)$$

where

$$\bar{X} = \left( \bar{S} - \omega^2 \bar{M} \right) \quad (4)$$

Taking into account (1, 2), we find that sinusoidal functions are interoperable. So we may use the formula (5.3.7), getting:

$$\Delta g = \frac{-j\omega p \otimes p}{p(\bar{X} + j\omega\bar{R}) \otimes p} p. \quad (5)$$

From the formula (5)  $\Delta g$  may be calculated directly (without using the calculus of operations).

**Example 1. One branch.** If there is only one branch, then from (5) we getting:

$$\Delta g = \frac{-j\omega p \otimes p}{p(X + j\omega R) \otimes p} p$$

or

$$\Delta g = \frac{-j\omega p}{X + j\omega R}. \quad (6)$$

On the first iteration  $g = 0$ ,  $p = -E$  and from (6) it follows, that

$$\Delta g = \frac{j\omega E}{(X + j\omega R)}, \text{ which leads us to the known formula } \Delta g = \frac{E}{Z},$$

$$\text{where } Z = \left[ \frac{S}{j\omega} + j\omega \cdot M + R \right].$$

Generally, if on a certain iteration  $g = \frac{E}{Z_1}$ , then  $q = \frac{E}{j\omega Z_1}$  and

$$p = (X + j\omega R) \cdot q - E = (X + j\omega R) \cdot \frac{E}{j\omega Z_1} - E = nE,$$

where  $n = \frac{(X + j\omega R) - j\omega Z_1}{j\omega Z_1}$ , and, further, by the formula (6)

$$\Delta g = \frac{-j\omega p}{(X + j\omega R)} = \frac{-j\omega nE}{(X + j\omega R)}.$$

Therefore, the new value of the function is

$$g =: g + \Delta g = \frac{E}{Z_1} + \Delta g = E \frac{1}{Z_1} + \frac{-j\omega}{(X + j\omega R)} \cdot \frac{(X + j\omega R) - j\omega Z_1}{j\omega Z_1} E,$$

i.e., as well as after the first iteration,  $g = \frac{j\omega E}{(X + j\omega R)}$ .

The integrals (4.16) and (4.17) in this case, taking into account (1) and (2), look as:

$$F_1(q) = \frac{\pi}{\omega} \left( q \left( \bar{S} + \omega^2 \bar{M} \right) - 2E \right) \otimes q, \quad (7)$$

$$F_2(q) = -\pi (\omega q \bar{R} + 2E) \otimes q. \quad (8)$$

## 5. The system of linear algebraic equations

The aforementioned results for linear differential equations and for sinusoidal current electric circuits may be interpreted as a solution method for a system of linear algebraic equations with complex coefficients.

### 5.1. Method 1.

The system being solved should have the following form

$$(a + jb)x = c, \quad (1)$$

where

$x$  – the complex variables vector,

$a, b$  – given square matrixes,

$c$  - a given vector.

Assuming that  $g = x$ ,  $\bar{R} = a$ ,  $\frac{\omega^2 \bar{M} - \bar{S}}{\omega} = b$ ,  $\bar{E} = c$ , from (3.20) we

may find the parameters of an electric circuit simulating the considered system of linear algebraic equations with complex equations coefficients.

On each iteration the new value of charge is found from the formula

$$x =: x - \frac{p \otimes p}{(pa + jpb) \otimes p} p,$$

that follows from (5.4.5). In this connection, the movement to an optimum of definite functional is progressed by the gradient that has the form  $p = (a + jb)x - c$ . During the movement to an optimum the norm

$\|p\|$  of this gradient is decreased. The following fig. 1 shows the graph of  $\|p\|$  as a function of the iteration number - see also the the functions

test2, test3, testN. The following fig. 2 shows the graph of  $\log\|p\|$  as a function of the iteration number.

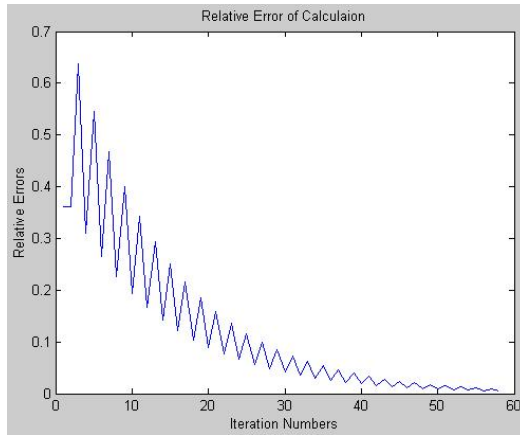

Fig. 1

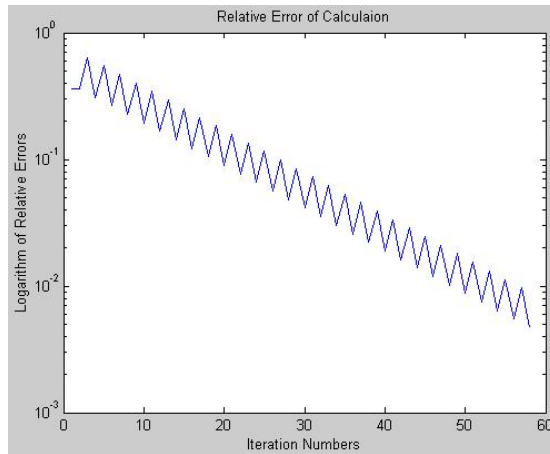

Fig. 2.

**Example 1.** A program `SinLin` for solving a system of linear equations with complex coefficients of the type  $Z*q=E$  is given in the annex [52].

### About convergence

As follows from the section 4.2, the iterative process *converges*, if the matrices  $M$  and  $R$  are of *fixed sign* (positive or negative definite).

**Example 1b.** Fig. 3 shows the example of the process divergence in the case of solving a three equations with complex coefficients in the MATLAB system. Here the matrix  $M$  is **not** of *fixed sign*, the process diverges and is stopped when the error is 100 times higher

than the error at the process beginning – see function `test3r`, which uses function `SinLin`.

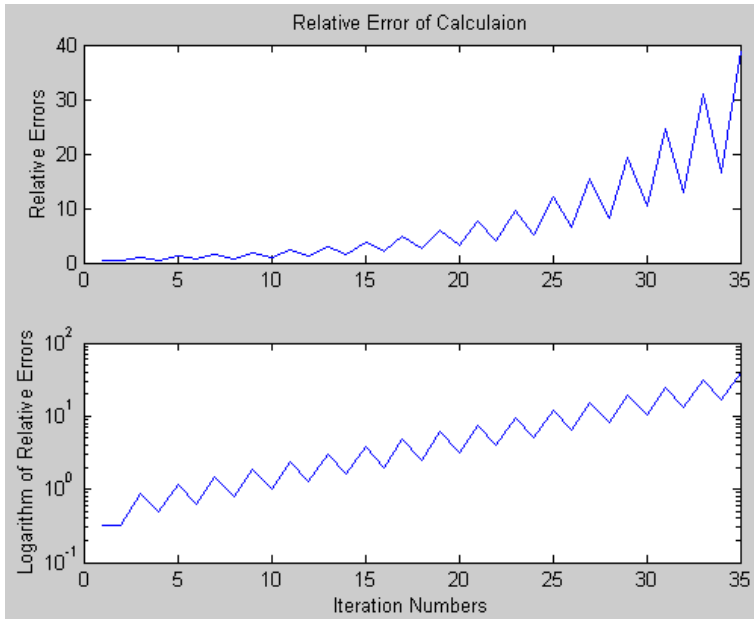

Fig. 3.

### About speed and precision

**Example 1c.** Comparing the results of solving  $N$  equations with complex coefficients in the MATLAB system with the aid of the discussed algorithm and the traditional one - see functions `testNv`, `testNe` correspondingly. Parameter `comp` serves for precision comparison for this and the traditional algorithms and is computed by the formula

```
qt = Z\E;
nqt=norm(qt);
nq=norm(q);
comp=abs((nqt-nq)/nqt);
```

Fig. 4 shows graphs of the iteration number and the error `comp` as functions of dimension number  $N$  with fixed value `maxEr`. One can see that, first, `comp` < `maxEr` and, second, the iteration number is proportional to the dimension number  $N$ .



Fig. 5 shows graphs of the iteration number and the error comp as functions of given value  $\text{maxEr}$  with fixed dimension number  $N$ . one can see that, first,  $\text{comp}$  is proportional to  $\text{maxEr}$  and, second, the iteration number is proportional to  $\text{maxEr}$ .

Thus ,

- $\text{comp} \sim \text{maxEr}$ ,
- $\text{comp}$  is proportional to  $\text{maxEr}$ ,
- iterations number is proportional to  $\text{maxEr}$ ,
- iterations number is proportional to dimension number  $N$ .

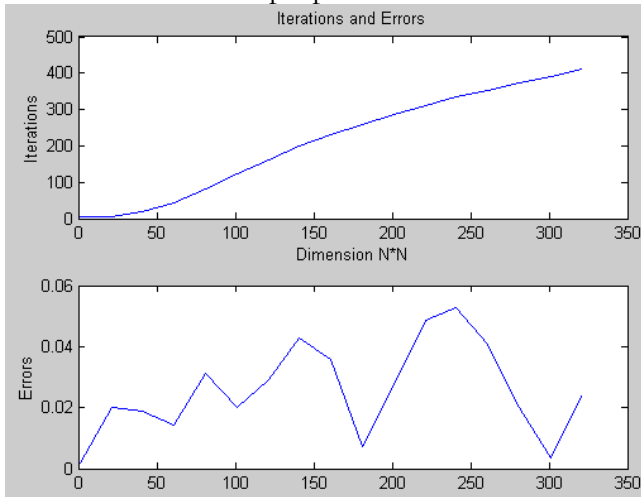

Fig. 4.

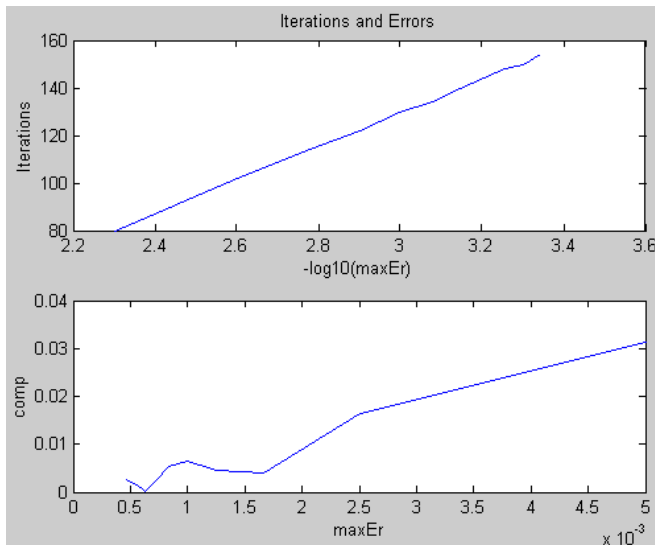

Fig. 5.

According to section 2 let us consider now the solution of ill-determined systems of the type (1). The integrals (5.4.7) и (5.4.8) in this case take the form:

$$F_1(q) = \frac{\pi}{\omega} (x^T a - 2c) \otimes q, \quad (2)$$

$$F_2(q) = -\pi (ax^T b + 2jc) \otimes x. \quad (3)$$

**Underdetermined system.** In such system the number of equations is less than the number of variables. In this case the system (1) may be complemented by an equation

$$(jn^T + m^T) = 0, \quad (4)$$

where  $n, m$  – matrices of given weight coefficients. The system (1) is transformed into the system:

$$\begin{vmatrix} a \\ m \end{vmatrix} x + j \begin{vmatrix} b \\ n \end{vmatrix} x = \begin{vmatrix} c \\ 0 \end{vmatrix}, \quad (5)$$

and functionals (2) and (3) with comparatively large weight coefficients will take the form of following functions:

$$F_1(x) = x^T m \otimes x, \quad (6)$$

$$F_2(x) = -x^T n \otimes x. \quad (7)$$

These functions correspond to minimization of a weighted sum of squared variables. Note, that the matrices  $n, m$  are going to

complement the matrices  $a, b$  to square matrices  $\begin{vmatrix} a \\ m \end{vmatrix}, \begin{vmatrix} b \\ n \end{vmatrix}$ .

**Overdetermined system.** In such system the number of equations is larger than the number of variables. In this case the system (1) may be transformed to the form:

$$\begin{vmatrix} a \\ m \end{vmatrix} \cdot \begin{vmatrix} x \\ y \end{vmatrix} + j \begin{vmatrix} b \\ n \end{vmatrix} \cdot \begin{vmatrix} x \\ y \end{vmatrix} = c, \quad (8)$$

where  $y$  – the vector of complementary variables  $n, m$  – matrices of given weight coefficients of the complementary variables. Then the functionals (2) and (3) with comparatively large weight coefficients will take the form of following functions:

$$F_1(x) = y^T m \otimes y, \quad (9)$$

$$F_2(x) = -y^T n \otimes y \quad . \quad (10)$$

These functions correspond to the minimization of a weighted sum of squared residuals. The matrices  $n$ ,  $m$  are going to complement matrices

$$a, b \text{ to square matrices } \begin{vmatrix} a & 0 \\ & m \end{vmatrix}, \begin{vmatrix} b & 0 \\ & n \end{vmatrix}.$$

## 5.2. Method 2.

According to section 2 we shall consider now the solution of ill-determined systems of the type (5.2.14). The integrals (5.2.18) and (5.2.19) in this case take the form

$$F_1(x) = \frac{\pi}{\omega} \left( x^T a b^T \left( 1 + \omega^2 \right) - 2 \left( a c + \frac{b c}{j \omega} \right)^T \right) \otimes x, \quad (11)$$

$$F_2(x) = -\pi \left( \omega x^T \left( a a^T + b b^T \right) + 2 \left( a c + \frac{b c}{j \omega} \right)^T \right) \otimes x, \quad (12)$$

or

$$F_1(x) = \frac{\pi}{\omega} \left( x^T \left( 1 - \omega^2 \right) a^T b + 2 \left( b + \frac{a}{j \omega} \right) c \right) \otimes x, \quad (13)$$

$$F_2(x) = \frac{\pi}{\omega} \left( \omega^2 x^T \left( a a^T + b b^T \right) + 2 j \omega \left( b + \frac{a}{j \omega} \right) c \right) \otimes x. \quad (14)$$

or, with  $\omega = 1$ ,

$$F_1(x) = -2\pi \left( x^T a^T b + (j a - b) c \right) \otimes x, \quad (15)$$

$$F_2(x) = \pi \left( x^T \left( a a^T + b b^T \right) + 2(a + j b) c \right) \otimes x. \quad (16)$$

The solution of system (5.2.14) with these functions' minimization is equivalent to the solution of system (5.2.17), which in this case takes the following form:

$$a^T b x \left( -\omega^2 \right) + j \omega \left( a a^T + b b^T \right) + \left( b + \frac{a}{j \omega} \right) c = 0 \quad (17)$$

or, with  $\omega = 1$ ,

$$j \left( a a^T + b b^T \right) + (b - j a) c = 0.$$

or, finally,

$$\left( a a^T + b b^T \right) + (a - j b) c = 0. \quad (18)$$

One can see that the equation (18) differs from the equation (5.2.14) by the factor  $(a - j b)$ . If the system (5.2.14) is well-determined, then it

and the system (18) have only one solution. Let us consider the cases when the system (5.2.14) is ill-determined.

Let us note that in an equation with real coefficients  $b=0$ , and the equation (18) becomes

$$aa^T x + ac = 0, \tag{19}$$

and the minimized function (16) becomes

$$F_2(x) = \pi \left( x^T aa^T + 2ac \right) \otimes x. \tag{20}$$

**Underdetermined system.** In such system the number of equations is less than the number of variables. However, as was shown above, the solution obtained by this method has minimized the quadratic forms (15) and (16).

**Overdetermined system.** In such system the number of equations is larger than the number of variables, and the system (5.2.14) has no solution. However, as was shown above, the solution obtained by this method has minimized the quadratic forms (15) and (16) with a certain residual.

So, to solve the system (5.2.14) by the considered method, this system should be transformed into system (18). This rule is applicable to any type of system (5.2.14) – well-determined, underdetermined or overdetermined.

**Example 2.** A program `SinLin2` for solution of ill-determined linear equations system  $(a+j*b)*q+c=0$  is given in the annex [52].

### 5.3. About Matrix Processor

It is well known that 75% of all numerical mathematical problems are essentially the problems of linear algebra [19]. Among these problems a large share falls on the solution of linear equations system with (generally speaking) complex coefficients. We can literally say that matrix processors owe their very appearance to these problems. But in these problems only the multiplication of matrices harmonizes ideally with the with the possibility of parallel computations in matrix processors. Other operations, necessary for bringing a linear system to a form easy-to-use for iterations, or for matrices inversion [20], are ill-suited for paralleling. This problem, along with the high cost of matrix processors, is an obstacle to their expansion.

Offered above method and algorithms is presented for solving a system of linear equations with complex coefficients (including

underdetermined and overdetermined systems), involving only multiplication of vectors (the inverse matrix computation is absent). The matrix processor (specially designed for this problem) is significantly simplified and is able (without essential hardware expenses) to realize pipeline data processing without important hardware changes.

It follows from the above-stated (see the function **SinLin** in Example 1), that in the process of solving a linear equations system with complex coefficients by the discussed method, only the following operations with complex vectors and matrices are being used: addition and subtraction of vectors:

From the above-stated follows (see function **SinLin** in an example of vectors multiplication,

1. addition and subtraction of matrices,
2. multiplication of matrices,
3. calculating the norm of vector  $x$

Obviously,

- addition and subtraction of matrices (3) is reduced to addition and subtraction of vectors (1),
- multiplication of matrices (4) is reduced to multiplication of vectors (2),
- calculating a vector's norm (5) is reduced to multiplication of vectors (2) and addition of vectors (1).

Hence, for the solution of linear equations system we may construct a matrix processor which provides only operations (1, 2). The inverse matrix computation is absent. Such matrix processor may be realized by a specialist without much problems. Such processor should contain only summators and perform conveyer data processing. The number of summators  $S$  should be in proportion with the processor's volume and in inverse proportion with the performance time of these operations.

On every iteration the multiplication of a square matrix by a vector is being performed. The performance time of such operation by an ordinary processor is proportional to the vector's dimension  $N$ , and the number of iterations (as was mentioned above) is proportional to the dimension  $N$ . So, the solution time for an ordinary processor is proportional to  $N^3$ . For a proposed matrix processor it is proportional to  $N^3/S$ .

## 6. Computing linear electric circuits with sinusoidal current

These circuits may have arbitrary configuration and may contain

- resistances,
- capacities
- inductances and inter-inductances,
- transformers, including multiwinding
- transformers with complex transformation coefficients, including multiwinding,
- voltage sources,
- current sources.

The existing methods of calculation for the named electric circuits are based on their description by a linear equations system and subsequent solution of this system. In our case the electric circuit before the calculation is being transformed into unconditional electric circuit with parameters (voltages and current) that are almost (within a given precision) similar to those of the initial electric circuit. Then this unconditional electric circuit is computed with the aid of the described method of finding an optimum of a certain functional. Note that unlike the known methods

- there exists an inverse proportion between the precision and the solution time; in practice it means that the user may quickly look through the approximate solutions, and then compute more precisely the chosen variant;
- the number of equations is reduced by half (to be more accurate - the equation system for an ordinary electric circuit contains the equations of the First and Second Kirchhoff Law, and the equations system for unconditional electric model contains only the equation of the Second Kirchhoff Law);
- it may be possible to extend this method for non-linear (with respect to the power sources parameters) system.

As it follows from the above said, the unconditional electric circuit is described by an equations system of the type

$$\left( j \left( \omega \cdot \bar{M} - \frac{1}{\omega} \bar{S} \right) + \bar{R} \right) g - \bar{E} = 0, \quad (1)$$

where  $\bar{S}$ ,  $\bar{R}$ ,  $\bar{M}$ ,  $\bar{E}$  are determined according to the following formulas

$$\begin{aligned}
\bar{S} &= S, \\
\bar{R} &= \left( R + \rho \cdot N^T N + \rho \cdot T_1 T_1^T - \omega^2 \rho \cdot T_2 T_2^T \right) \\
\bar{M} &= \left( M + \rho \cdot T_2 T_1^T + \rho \cdot T_1 T_2^T \right) \\
\bar{E} &= \left( E - \rho \cdot \left( N^T H + T_1 P + T_2 P' \right) \right)
\end{aligned} \tag{2}$$

which follow from (3.20).

The computation algorithm consists in solving repeatedly the equations system (1) with the same value of Second Kirchhoff Law error and an increasing value of methodic resistance. This increase leads to the decrease of the First Kirchhoff Law error. So the algorithm is as follows:

1. Transforming the circuit to standard form – see Fig. 3.3. It was shown above that such transformation is possible for any configuration of multiwinding transformers in the circuit.
2. Preparing the tables describing the initial electric circuit.
3. Forming from these tables the matrices  $R$ ,  $M$ ,  $S$ ,  $N$ ,  $T_1$ ,  $T_2$  and the vectors  $E$ ,  $H$ ,  $P$ .
4. Choosing  $\varepsilon_{1\min}$ ,  $\varepsilon_{2\min}$  from the possible values of the First and Second Kirchhoff Laws errors. The possible values of the First and Second Kirchhoff Laws errors are relative to maximal values of currents and potentials.
5. Choosing the initial value of methodic resistance. It may be equal to the average value of all complex resistances of the circuit branches.
6. Computing the matrices and vectors by the formulas (2).
7. Solving the equation system (1) with a given value of possible relative Second Kirchhoff Law error  $\varepsilon_{2\min}$  - see the previous section 5. The current value of Second Kirchhoff Law error  $\varepsilon_2$  on each iteration is calculated by the formula

$$\varepsilon_2 = \max(|p|) / \max(|E|, |\varphi|, |\phi|), \tag{3}$$

Here the gradient  $p$  is equal to the value of the right side in the expression (1). On the first iteration, when the potentials  $\varphi$ ,  $\phi$  are still unknown, the values  $\varphi = 0$ ,  $\phi = 0$  are taken.

8. Computing the value of First Kirchhoff Law error. For that the node currents are computed by the formulas

$$i = Ng + H, \tag{4}$$

$$m = \left( T_1^T + j\omega \cdot T_2^T \right) \mathcal{J} + P, \tag{5}$$

which follow from (3.18) и (3.19). This error is

$$\varepsilon_1 = \max(|i|, |m|) \max(|g|, |H|, |P|), \tag{6}$$

The node potentials are also computed

$$\varphi = -\rho \cdot i, \tag{7}$$

$$\phi = -\rho \cdot m. \tag{8}$$

If the value of error  $\varepsilon_1$  is less than possible value, the computation should be stopped.

9. Increasing the value of methodic resistance  $\rho = k_\rho \cdot \rho$  (where  $k_\rho$  is a given coefficient) and passing to p. 6. Along with the increase of  $\rho$  the First Kirchhoff Law error  $\varepsilon_1$  decreases, while the Second Kirchhoff Law error remains constant. Fig. 1 shows the dependences of these parameters on the iterations number in the electric circuit computation, in the Example 2 when  $k_\rho = 1.25$ .

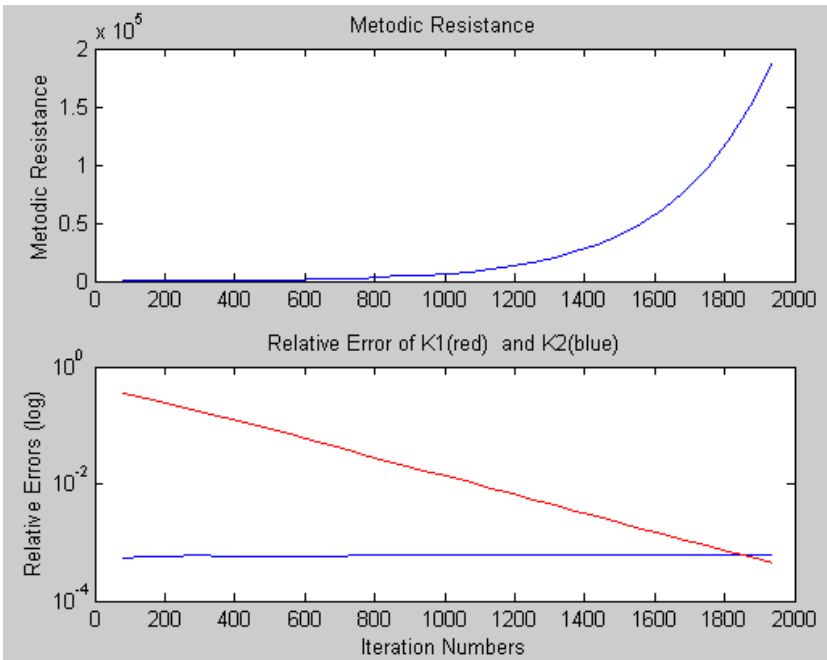

Fig. 1.



**Example 1.** Further the program **SinCir** is given, realizing pp. 5 - 9 of the described algorithm for electric circuit computation. The notations in this program comply with the above cited notations. More concretely:

```

% EEreal,SSS,LLL,RRR,HH,PP - row vectors for
%      E,S,L,R,H,P;
% NN - incidence matrix N;
% tran1,tran2 - matrices  $T_1, T_2$ ;
% eK1min,eK2min,omega,stepRo - values
%       $\varepsilon_{1\min}, \varepsilon_{2\min}, \omega, k_\rho$  accordingly;
% Wmax - tolerant number of external cycles
%      with  $k_\rho$  growing;
% maxIter - tolerant total number of internal cycles
%      (in the SinLin3 function );
% kromin - the coefficient of initial methodic
%      resistance increase;
% res=0 - OK;
% res=1 - many internal iterations;
% res=2 - large error;
% res=3 - many external iterations.

```

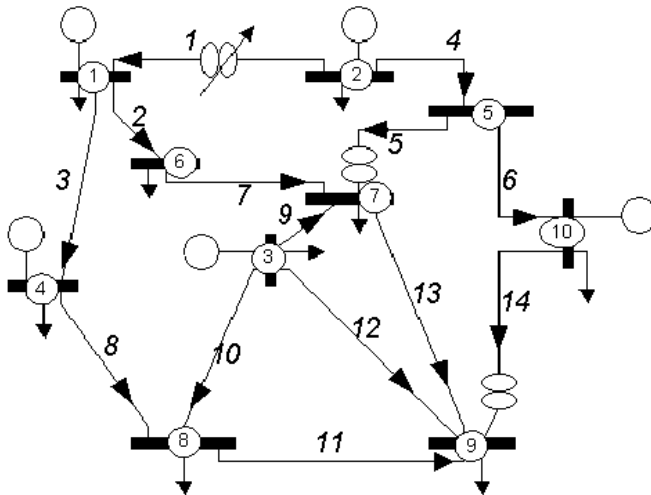

Fig. 2.

**Example 2.** An example of the electric circuit of a certain power system is shown in the Fig. 2. On this diagram the generators are

denoted by empty circles, and transformer – by double circles. The diagram contains 14 branches, of them – 3 transformer branches and 10 nodes, of them – 5 generator nodes and 5 load nodes. After transformation the diagram assumed the form shown on Fig. 3. In the transformed circuit the generators of nodes 1, 2, 3, 4 are depicted by fixed current sources, the generator f node 10 is depicted by a line with fixed voltage source, and the transformer – by two branches. To test all the possibilities, the first transformer node is supplemented by a current source, and the second transformer has a complex transformation ratio. Totally this circuit contains 22 branches, 10 nodes and transformer matrix of 3x3 dimensions. Positive directions of voltages and currents are depicted by arrows. For the description of standard circuit on the Fig. 3 the tables of nodes **Nodes**, branches **Branches** and transformers **Trans** are arranged. From these tables the row vectors  $E, S, L, R, H, P$  and matrices  $N, T_1, T_2$  are formed. Further the **SinCir** function is used. After performing the computation these tables are supplemented by the parameters  $i, m, \varphi, \phi, g, \varepsilon_1, \varepsilon_2$ .

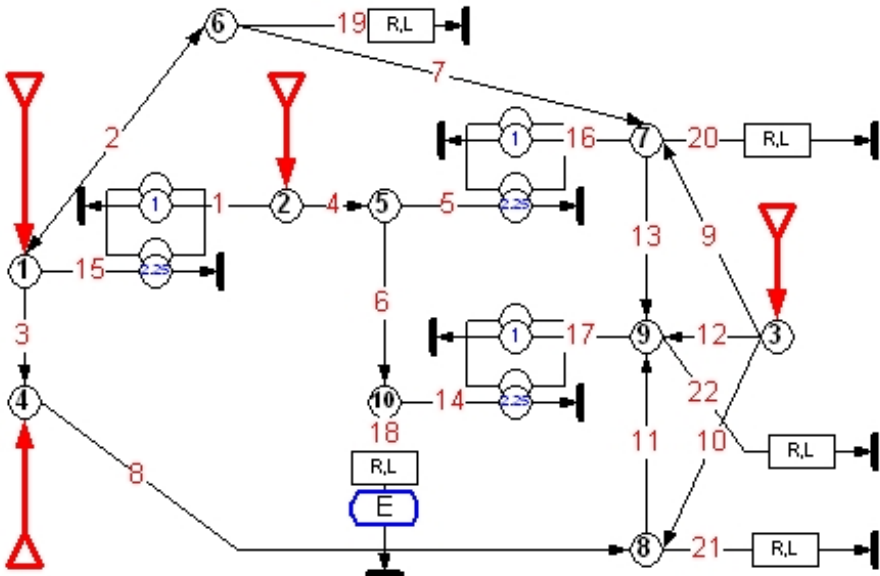

Fig. 3.

**Nodes**

| Node | $\text{Re}(\phi)$ | $\text{Im}(\phi)$ | $\text{Re}(H)$ | $\text{Im}(H)$ | $\varepsilon_1$ |
|------|-------------------|-------------------|----------------|----------------|-----------------|
| 1    | 326               | 235               | -5.07          | -1.79          | 0.0021          |
| 2    | 677               | 419               | -6.23          | -1.87          | 0.0042          |
| 3    | 386               | 70                | 2.26           | 3.68           | 0.0021          |
| 4    | 365               | 215               | -2.55          | 1.26           | 0.0023          |
| 5    | 724               | 208               | 0              | 0              | 0.0040          |
| 6    | 333               | 166               | 0              | 0              | 0.0020          |
| 7    | 334               | 99                | 0              | 0              | 0.0018          |
| 8    | 364               | 116               | 0              | 0              | 0.0020          |
| 9    | 351               | 69                | 0              | 0              | 0.0019          |
| 10   | 767               | 3                 | 0              | 0              | 0.0041          |

**Branches**

| Num | nBeg | nEnd | $\text{Re}(E)$ | $\text{Im}(E)$ | R    | L   | S | $\text{Re}(g)$ | $\text{Im}(g)$ | $\varepsilon_2$ |
|-----|------|------|----------------|----------------|------|-----|---|----------------|----------------|-----------------|
| 1   | 2    | 0    | 0              | 0              | 0.03 | 0.7 | 0 | 0.51           | -0.19          | 4.10            |
| 2   | 1    | 6    | 0              | 0              | 0.44 | 0.1 | 0 | -2.2           | -0.1           | 4.93            |
| 3   | 1    | 4    | 0              | 0              | 0.27 | 0.1 | 0 | -0.61          | -1.17          | 2.82            |
| 4   | 2    | 5    | 0              | 0              | 0.25 | 0.1 | 0 | -6.74          | -1.7           | 4.03            |
| 5   | 5    | 0    | 0              | 0              | 0.03 | 0.7 | 0 | -0.37          | -0.05          | 2.98            |
| 6   | 5    | 10   | 0              | 0              | 0.1  | 0.1 | 0 | -6.36          | -1.65          | 10.49           |
| 7   | 6    | 7    | 0              | 0              | 0.44 | 0.1 | 0 | -2.08          | -0.21          | 5.58            |
| 8   | 4    | 8    | 0              | 0              | 0.27 | 0.1 | 0 | -3.16          | 0.09           | 1.8             |
| 9   | 3    | 7    | 0              | 0              | 0.14 | 0.1 | 0 | 0.89           | 1.6            | 2.27            |
| 10  | 3    | 8    | 0              | 0              | 1.92 | 0.1 | 0 | 1.34           | 0.89           | 3.29            |
| 11  | 8    | 9    | 0              | 0              | 0.99 | 0.1 | 0 | -1.36          | 0.34           | 4.26            |
| 12  | 3    | 9    | 0              | 0              | 0.27 | 0.1 | 0 | 0.03           | 1.19           | 2.89            |
| 13  | 7    | 9    | 0              | 0              | 0.27 | 0.1 | 0 | -0.85          | -0.41          | 4.81            |
| 14  | 10   | 0    | 0              | 0              | 0.03 | 0.7 | 0 | 0.67           | 0.03           | 13.45           |
| 15  | 1    | 0    | 0              | 0              | 0.01 | 0   | 0 | -2.26          | -0.52          | 7.64            |
| 16  | 7    | 0    | 0              | 0              | 0.01 | 0   | 0 | 0.85           | 0.01           | 17.94           |
| 17  | 9    | 0    | 0              | 0              | 0.01 | 0   | 0 | -1.5           | -0.07          | 16.44           |
| 18  | 10   | 0    | 750            | 0              | 0.01 | 0   | 0 | -7.03          | -1.68          | 17.45           |
| 19  | 6    | 0    | 0              | 0              | 8    | 7   | 0 | -0.12          | 0.11           | 10.2            |
| 20  | 7    | 0    | 0              | 0              | 50   | 0.5 | 0 | -1.19          | 1.79           | 6.78            |
| 21  | 8    | 0    | 0              | 0              | 157  | 1.5 | 0 | -0.46          | 0.64           | 9.61            |
| 22  | 9    | 0    | 0              | 0              | 81   | 0.8 | 0 | -0.67          | 1.2            | 5.37            |

**Trans**

| Num | $\text{Re}(\phi)$ | $\text{Im}(\phi)$ | $\text{Re}(P)$ | $\text{Im}(P)$ | $\varepsilon_{1t}$ | См. продол-<br>жение |
|-----|-------------------|-------------------|----------------|----------------|--------------------|----------------------|
| 1   | 319               | 237               | 1.1            | 0.9            | 0.0021             |                      |
| 2   | 318               | 91                | 0              | 0              | 0.0018             |                      |
| 3   | 334               | 71                | 0              | 0              | 0.0018             |                      |

**Trans** (continuation of columns with branches numbering)

| Num | B1   | B5          | b14  | B15 | B16 | b17 | ... |
|-----|------|-------------|------|-----|-----|-----|-----|
| 1   | 2.25 | 0           | 0    | 1   | 0   | 0   |     |
| 2   | 0    | 2.25-0.25*j | 0    | 0   | 1   | 0   |     |
| 3   | 0    | 0           | 2.25 | 0   | 0   | 1   |     |

**Example 3.** Let us consider the electric circuit shown in the Fig. 3. In this circuit only the transformers  $T_0$  and current sources  $P$  in transformer nodes are present. Methodic resistances are also shown there. The circuit contains  $n$  uniform elements and is described by two equations:

$$q'_2 = N_2 q'_1, \quad q'_1 + T_0 q'_2 = P.$$

The matrix  $N_2$  is:

$$N_2 = \left\{ \begin{array}{cccccc} 1 & -1 & 0 & 0 & \dots & 0 \\ 0 & 1 & -1 & 0 & \dots & 0 \\ 0 & 0 & 1 & -1 & \dots & 0 \\ \dots & \dots & \dots & \dots & \dots & \dots \\ 0 & 0 & 0 & 0 & \dots & 1 \end{array} \right\} n,$$

←-----  $n$  -----→

and the matrix  $T_0$  is a quadratic  $n*n$ -diagonal matrix. Consider  $2n$ -dimensional vector  $q = \begin{bmatrix} q_1 \\ q_2 \end{bmatrix}$ . Then the incidence matrix and the transformer matrix of the total circuit will assume the following form:

$$N = [N_2 \quad -D_1], \quad T = [D_1 \quad T_0]$$

where  $D_1$  -  $n*n$  - diagonal identity matrix. All other matrices and vectors for this circuit are equal to zero. Fig. 4 (see also function `testDigDir`) gives the results of this circuit computation with  $n = 8, t_{kk} = 0.7, P_1 = 1.0 + 0.2j, P_{k>1} = 0$ .

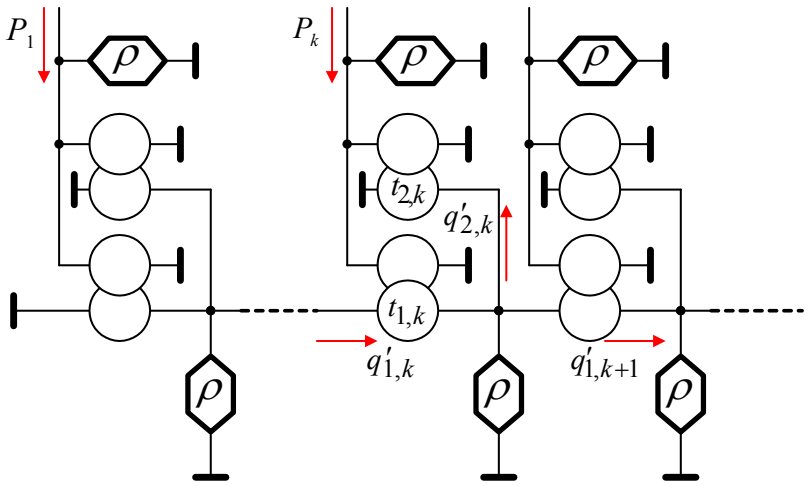

Fig. 3.

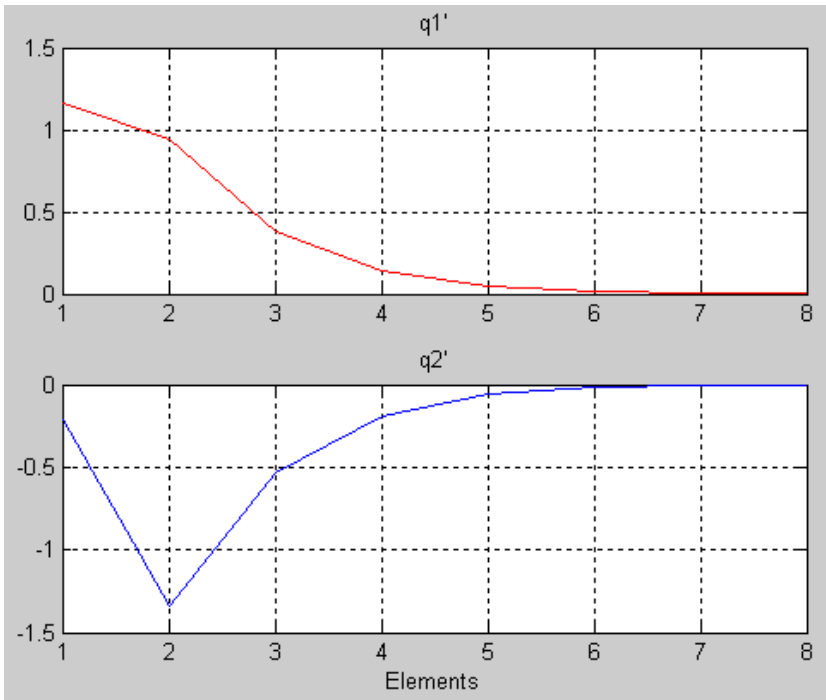

Fig. 4.

## 7. Trigonometric Series

In the case when the voltages and the currents of the sources are represented by trigonometric series, the computations by the formulas (5.4.3, 5.4.5) in every iteration should be performed for each harmonic.

## 8. Periodical Functions

In this case the formulas (4.11), where  $T$  is the functions' period, are used directly for the main coefficients computations. For periodical functions in this formulas

$$\int_0^T [p^T \bar{R}q - p^T \bar{R}q'] dt = 0,$$

$$\int_0^T (p^T \bar{S}q - p^T \bar{M}q'' + \hat{p}^T \bar{S}q' + p'^T \bar{M}q') dt = 0.$$

## 9. Exponential Functions

Here we shall consider exponential functions  $f(t) = u \cdot e^{\alpha t}$ , where  $\alpha$  is a real or complex number. Such functions are (as was stated above) interoperable. Let us give some examples.

**Example 1.** Consider an equation

$$Sq + Rq' + Lq'' - E = 0.$$

Characteristic equation of the corresponding homogeneous equation

$$Sq + Rq' + Lq'' = 0 \text{ is } [16] \quad S + R\beta + L\beta^2 = 0, \quad \text{its roots}$$

$$\eta = \frac{-R \pm \sqrt{R^2 - 4LS}}{2L}. \text{ The solution of homogeneous equation in this}$$

case will be as follows:

$$\text{if } (R^2 - 4LS) \geq 0 \text{ then } q = e^{\alpha t} (c_1 e^{\eta_1 t} + c_2 e^{\eta_2 t})$$

$$\text{if } (R^2 - 4LS) < 0 \text{ then } q = e^{\alpha t} (c_1 \cos(\beta t) + c_2 \sin(\beta t)),$$

$$\alpha = \frac{-R}{2L}, \quad \beta = \frac{\sqrt{R^2 - 4LS}}{2L},$$

where  $c_1, c_2$  are arbitrary constants.

Let  $E = u \cdot e^{\alpha \cdot t}$ . Notice that a particular solution in this case will  $q = m \cdot E$ , where  $m = \frac{1}{S + R\alpha + \alpha^2 L}$ .

**Example 2.** Continuing example 1, let us find the function  $q$  using the stated method. On the first iteration  $q=0$  and, as follows from (4.11),

$$p = Sq + Lq'' - E = -E, \quad p' = -\alpha \cdot E,$$

$$A'_1 = \frac{-1}{2} \int_0^T E^2 dt, \quad B_1 = 2(S + \alpha^2 L) \int_0^T E^2 dt,$$

$$A'_2 = \frac{-1}{2} \int_0^T E^2 dt, \quad B_2 = 2R \int_0^T E^2 dt.$$

From (4.10) we find that

$$q' = \frac{2\mu \cdot (A'_1 + A'_2)}{B_1 + \mu \cdot B_2} p = \frac{-2\mu}{2(S + \alpha^2 L) + \mu 2R} (-E)$$

or

$$q' = \left( \frac{\mu E}{S + \alpha^2 L + \mu R} \right).$$

Evidently, for exponential function  $\mu = \alpha$ . Therefore

$$q' = kE, \quad \text{where } k = \frac{1}{\left( \frac{S}{\alpha} + \alpha L + R \right)},$$

Which coincides with the result, obtained in example 1. Generally, if on a certain iteration  $q=hE$ , then

$$p = Sq + Lq'' - E = (Sh + \alpha^2 hL - 1)E = nE,$$

An further, according to formula (4.10),

$$\Delta q' = \frac{-S \int_0^T qpdt - \mu^2 M \int_0^T qpdt - \mu R \int_0^T qpdt + \int_0^T Epdt}{S \int_0^T ppdt + \mu^2 M \int_0^T ppdt + \mu R \int_0^T ppdt} \mu \cdot p$$

or

$$\Delta q' = \frac{\left( S - \mu^2 M - \mu R \right)_0^T \int_0^T q p dt + \int_0^T E p dt}{\left( S + \mu^2 M + \mu R \right)_0^T \int_0^T p^2 dt} \mu \cdot p =$$

$$= \frac{\left( S - \mu^2 M - \mu R \right)_{n+n}}{\left( S + \mu^2 M + \mu R \right)^2} \mu \cdot n E = \frac{h \left( S - \mu^2 M - \mu R \right) + 1}{\left( S + \mu^2 M + \mu R \right)} \mu \cdot E,$$

And the new value of the function  $q$  will be

$$q' =: q' + \Delta q' = hE + \Delta q' = hE + \frac{h \left( S - \mu^2 M - \mu R \right) + 1}{\left( S + \mu^2 M + \mu R \right)} \mu \cdot E$$

or  $q' = \frac{\mu \cdot E}{\left( S + \mu^2 M + \mu R \right)}$  i.e., as after the first iteration,

$$q' = kE, \text{ where } k = \frac{1}{\left( \frac{S}{\alpha} + \alpha L + R \right)}.$$

## 10. The Functions Determined on the Positive Time Semiaxis.

The theory of functionals construction, outlined above, assumes that the used functions are twice differentiable and is not extended for discontinuous functions. However, the gradient descent method does not require such limitations. So it may be extended for discontinuous functions. The Pontryagin's maximum principle [18] permits to substantiate this assertion – see the next chapter.

Further we shall restrict our consideration to the type of functions, multiplied by a unite step  $\gamma(t)$ . As it will be clear from further discussion, we shall operate with functions of the type  $f(t) = u \cdot e^{\alpha \cdot t}$ ,  $f(t) = e^{\alpha t} \sin(\beta t)$ ,  $f(t) = e^{\alpha t} \cos(\beta t)$ . These functions in the section 5.3 have been called *interoperable* and the formula (5.3.7) for computing current increment is applicable to them. Let us transform this formula to the form:

$$\Delta q' = \frac{- \int_0^T p^T p dt}{\int_0^T p^T \bar{S} p dt + \mu^2 \int_0^T p^T \bar{M} p dt + \mu \int_0^T p^T \bar{R} p dt} \mu \cdot p. \quad (0)$$

or



$$\Delta q'(t) = \frac{a \cdot \mu}{S + \mu \cdot R + \mu^2 L} \cdot p(t), \quad (1)$$

where  $a, S, R, L$  are real numbers. This equation may be rewritten as

$$\Delta q'(t) \left( \frac{S}{\mu} + R + \mu \cdot L \right) = a \cdot p(t)$$

or

$$Sq + Rq' + Lq'' - E = 0.$$

The problem is to determine the current  $q(t)$  for various discontinuous functions. Therefore we shall now apply operational calculus [14]. Denote the image of  $f(t)$  as  $\bar{f}(\mu)$ .

If the image of gradient is

$$\bar{p}(\mu) = \frac{d(\mu)}{b(\mu)}, \quad (2)$$

Then, as it follows from (14),

$$\overline{\Delta q'}(\mu) = \frac{a \cdot \mu \cdot d(\mu)}{(S + \mu \cdot R + \mu^2 L) b(\mu)} \quad (3)$$

or

$$\overline{\Delta q}(\mu) = \frac{a \cdot \mu \cdot d(\mu)}{\mu \cdot (S + \mu \cdot R + \mu^2 L) b(\mu)} \quad (4)$$

If the function

$$F(\mu) = (S + \mu \cdot R + \mu^2 L) b(\mu) \quad (5)$$

has only prime roots  $\beta_m$ , then according to Heaviside's theorem [14] we find:

$$\Delta q = \frac{a}{Z(0)} + \sum_m \frac{a \cdot d(\beta_m) \beta_m}{\beta_m F'(\beta_m)} e^{\beta_m t}, \quad (6)$$

where

$$Z(\mu) = \frac{F(\mu)}{\mu \cdot d(\mu)}. \quad (7)$$

For  $S=0$  the following formula is used

$$\Delta q' = \frac{a}{Z(0)} + \sum_m \frac{a \cdot d(\beta_m) \beta_m}{F'(\beta_m)} e^{\beta_m t}, \quad (6a)$$

where

$$F(\mu) = (R + \mu L) \cdot b(\mu) \quad (5a)$$

and

$$Z(\mu) = \frac{F(\mu)}{d(\mu)}. \quad (7a)$$

## 11. Step Function

In this case  $f(t) = E \cdot \gamma(t)$ , where  $\gamma(t)$  - step unit. Let us first consider an example.

**Example 1.** Consider an equation

$$Sq + Rq' + Lq'' = E \cdot \gamma(t).$$

The characteristic equation for it will be [16]:

$$S + R\beta + L\beta^2 = 0,$$

Its roots:  $\eta = \frac{-R \pm \sqrt{R^2 - 4LS}}{2L}$ , its solution:

$$\text{if } (R^2 - 4LS) \geq 0 \text{ then } q = e^{-\alpha t} (c_1 e^{\eta_1 t} + c_2 e^{\eta_2 t})$$

$$\alpha = \frac{R}{2L}, \quad \beta = \frac{\sqrt{R^2 - 4LS}}{2L},$$

$$\text{if } (R^2 - 4LS) < 0 \text{ then } q = e^{-\alpha t} (c_1 \cos(\beta t) + c_2 \sin(\beta t)),$$

$$\alpha = \frac{R}{2L}, \quad \beta = \frac{\sqrt{4LS - R^2}}{2L},$$

where  $c_1, c_2$  are arbitrary constants. Let us find the arbitrary constants for  $(R^2 - 4LS) < 0$ . We have

$$q = \left\{ e^{\alpha t} (c_1 \cos(\beta t) + c_2 \sin(\beta t)) + \frac{E}{S} \right\},$$

as  $Sq = E$  with  $t \rightarrow \infty$ . Further we have

$$q' = \left\{ \begin{aligned} &\alpha \cdot e^{\alpha t} (c_1 \cos(\beta t) + c_2 \sin(\beta t)) + \\ &+ \beta e^{\alpha t} (-c_1 \sin(\beta t) + c_2 \cos(\beta t)) \end{aligned} \right\}$$

or

$$q' = \left\{ e^{\alpha t} \left( \begin{aligned} &(\alpha \cdot c_1 + \beta c_2) \cos(\beta t) + \\ &+ (\alpha \cdot c_2 - \beta \cdot c_1) \sin(\beta t) \end{aligned} \right) \right\},$$

For  $t = 0$  we have  $q' = 0$ . Therefore

$$(\alpha c_1 + \beta \cdot c_2) = 0. \tag{a}$$

Further we have

$$q'' = \left[ \begin{aligned} & \left\{ \alpha \cdot e^{\alpha t} \left( \begin{aligned} & (\alpha \cdot c_1 + \beta c_2) \text{Cos}(\beta t) + \\ & + (\alpha \cdot c_2 - \beta \cdot c_1) \text{Sin}(\beta t) \end{aligned} \right) \right\} + \\ & + \left\{ \beta \cdot e^{\alpha t} \left( \begin{aligned} & -(\alpha \cdot c_1 + \beta c_2) \text{Sin}(\beta t) + \\ & + (\alpha \cdot c_2 - \beta \cdot c_1) \text{Cos}(\beta t) \end{aligned} \right) \right\} \end{aligned} \right],$$

or

$$q'' = \left\{ e^{\alpha t} \left( \begin{aligned} & (\alpha^2 c_1 + 2\alpha \cdot \beta \cdot c_2 - \beta^2 c_1) \text{Cos}(\beta t) + \\ & + (\alpha^2 c_2 - 2\alpha \cdot \beta \cdot c_1 + \beta^2 c_2) \text{Sin}(\beta t) \end{aligned} \right) \right\}.$$

For  $t = 0$  we have  $Lq'' = E$ . Therefore

$$(\alpha^2 c_1 + 2\alpha \cdot \beta \cdot c_2 - \beta^2 c_1) = E/L \quad (\text{B})$$

Combining (a) and (B), we find:

$$c_2 = \frac{-\alpha c_1}{\beta}, \quad (\alpha^2 c_1 - 2\alpha^2 c_1 - \beta^2 c_1) = \frac{E}{L}, \quad c_1 = \frac{-E}{L(\alpha^2 + \beta^2)}. \quad (\text{C})$$

Substituting these constants to the expression for charge, we get

$$q = \frac{Ee^{-\alpha t}}{(\alpha^2 + \beta^2)\beta} (\alpha \cdot \text{Sin}(\beta t) - \beta \cdot \text{Cos}(\beta t)) + \frac{E}{S}. \quad (\text{D})$$

But

$$(\alpha^2 + \beta^2) = S/L. \quad (\text{E})$$

Therefore,

$$q = \left\{ \frac{Ee^{-\alpha t}}{S \cdot \beta} (-\beta \cdot \text{Cos}(\beta t) - \alpha \cdot \text{Sin}(\beta t)) \right\} + \frac{E}{S}.$$

Taking into account (d, e) and

$$\frac{\partial}{\partial t} \left\{ \frac{e^{-\alpha t}}{(\alpha^2 + \beta^2)} (-\alpha \cdot \text{Sin}(\beta t) - \beta \cdot \text{Cos}(\beta t)) \right\} = e^{-\alpha t} \text{Sin}(\beta t),$$

We find

$$q' = \left\{ \frac{Ee^{-\alpha t}}{L\beta} \text{Sin}(\beta t) \right\}$$

And further

$$q'' = \left\{ \frac{Ee^{-\alpha t}}{L\beta} (\beta \cdot \text{Cos}(\beta t) - \alpha \cdot \text{Sin}(\beta t)) \right\}.$$

Substituting the obtained expressions for  $q$ ,  $q'$  and  $q''$  in the initial equation, we can see that it turns into identity.

With  $(R^2 - 4LS) \geq 0$  we find

$$q = \frac{-1}{LS} \left( \frac{e^{\eta_1 t}}{\eta_1} + \frac{e^{\eta_2 t}}{\eta_2} \right),$$

$$q' = \frac{-1}{LS} \left( e^{\eta_1 t} + e^{\eta_2 t} \right),$$

$$q'' = \frac{-1}{LS} \left( \eta_1^2 e^{\eta_1 t} + \eta_2^2 e^{\eta_2 t} \right),$$

In particular, with  $S=0$  we have:  $\eta_1 = \eta_2 = R/L$  and

$$q = \frac{L}{R^2} e^{-\frac{R}{L}t}, \quad q' = -\frac{1}{R} e^{-\frac{R}{L}t}, \quad q'' = \frac{1}{L} e^{-\frac{R}{L}t}.$$

Let us consider some particular cases.

**Case 1.** On the first iteration  $p(t) = E \cdot \gamma(t)$ , which follows from (4.15) with  $q=0$ . Then  $\bar{p}(\mu) = \frac{E}{\mu}$ . In this case from (5.10.4) we find

$$\bar{\Delta q}(\mu) = \frac{a \cdot E}{\mu \cdot (S + \mu \cdot R + \mu^2 L)}$$

If the equation  $F(\mu) = (S + \mu \cdot R + \mu^2 L) = 0$  has for  $(R^2 - 4LS) < 0$  the roots  $\eta_{1,2} = -\alpha \pm j\beta$ , then  $F'(\mu) = 2L\mu + R$  and from (5.10.6) we obtain the function of charge increment as a sum of two items:

$$\Delta q_{1,2} = \frac{a \cdot E}{\eta_{1,2} (2L\eta_{1,2} + R)} e^{\eta_{1,2}t}. \quad (1)$$

After processing the expression with the aid of (5.3.6) we get (see also example 1):

$$\Delta q = \left\{ \frac{E e^{-\alpha t}}{S \cdot \beta} (-\beta \cdot \text{Cos}(\beta t) - \alpha \cdot \text{Sin}(\beta t)) \right\}.$$

$$\Delta q = \frac{-a \cdot E}{LS} \left( \frac{e^{\eta_1 t}}{\eta_1} + \frac{e^{\eta_2 t}}{\eta_2} \right) \text{ with } (R^2 - 4LS) \geq 0$$

$$\Delta q = \frac{a \cdot E \cdot L}{R^2} e^{-\frac{R}{L}t} \text{ with } S=0.$$

With the aid of these formulas the gradient may be computed from (4.1). It may be seen that the gradient is a sum of exponentials (with a

real or complex exponent), or of exponentials and functions of the type  $e^{\eta \cdot t} \text{Sin}(\omega \cdot t)$  and  $e^{\eta \cdot t} \text{Cos}(\omega \cdot t)$ .

**Example 1.** Let us consider a circuit with a sole branch, where  $L=0$ . For a sole branch the formula (5.10.0) may be reduced by  $\int_0^t p^T p dt$ , i.e. in the formula (5.10.1)  $a=-I$ . In this case on the first iteration we have:  $p(t)=-E \cdot \gamma(t)$ ,  $\bar{p}(t)=-E / \mu$ ,  $F(\mu)=(S+\mu R)\mu$ ,  $\overline{\Delta q}(\mu)=\frac{E}{Z(0)}+\frac{E}{\mu \cdot (S+\mu R)}$  - see (5.10.4),  $\eta=-S / R$ ,  $Z(0)=S$  - see

(5.10.7),  $q=\Delta q=\frac{E}{S}+\frac{E}{S}e^{-\frac{S}{R}t}$  - see (5.10.6). On the second iteration

$$p=(Sq+Rq'-E) \cdot \gamma(t)=\left(E\left(1+e^{-\frac{S}{R}t}\right)-Ee^{-\frac{S}{R}t}-E\right) \cdot \gamma(t)=0.$$

So the computation ends on the first iteration with the result

$$q=\frac{E}{S}\left(1+e^{-\frac{S}{R}t}\right)$$

**Example 2.** Let us consider a circuit with a sole branch, where  $S=0$ . In this case  $a=-I$  (see Example 1) and on the first iteration we have:  $p(t)=-E \cdot \gamma(t)$ ,  $\bar{p}(t)=-E / \mu$ ,  $F(\mu)=(R+\mu L)\mu$ ,  $\overline{\Delta q}'(\mu)=\frac{E}{Z(0)}+\frac{E}{\mu \cdot (R+\mu L)}$  - see (5.10.3),  $\eta=-R / L$ ,  $Z(0)=R$  - see

(5.10.7a),  $q'=\Delta q'=\frac{E}{R}-\frac{E \cdot L}{R^2}e^{-\frac{R}{L}t}$  - see (5.10.6a). On the second iteration

$$p=(Lq''+Rq'-E) \cdot \gamma(t)=\left(Ee^{-\frac{R}{L}t}+E\left(1-e^{-\frac{R}{L}t}\right)-E\right) \cdot \gamma(t)=0.$$

So the computation ends on the first iteration with the result:

$$q'=\frac{E}{R}\left(1-\frac{L}{R}e^{-\frac{R}{L}t}\right)$$

**Case 2.** Assume that  $p=E \cdot \gamma(t)e^{\lambda \cdot t}$ . Then  $\bar{p}(\mu)=\frac{E \cdot \omega}{\mu-\lambda}$ . From (5.10.4) we find

$$\overline{\Delta q}(\mu) = \frac{a \cdot \mu \cdot E \cdot \omega}{\mu \cdot (S + \mu \cdot R + \mu^2 L)(\mu - \lambda)}. \quad (2)$$

The equation  $F(\mu) = (S + \mu \cdot R + \mu^2 L)(\mu - \lambda) = 0$  has the roots  $\eta_{1,2} = -\alpha \pm j\beta$  and  $\lambda$ ,  $F'(\mu) = (S - \lambda R) + 2\mu \cdot (R - L\lambda) + 3\mu^2 L$ , and from (5.10.6) we obtain the function of charge increment as a sum of two summands (similarly to (1))

$$\Delta q_{1,2} = \frac{a \cdot E \omega}{F'(\eta_{1,2})} e^{\eta_{1,2} t}. \quad (3)$$

and another summand of the form

$$\Delta q_3 = \frac{a \cdot E \omega}{F'(\lambda)} e^{\lambda t}. \quad (4)$$

**Example 3.** Let us consider a circuit with a sole branch, where  $L=0$ . let us assume that for it on a certain iteration a charge  $q = a_0 + a_1 e^{-bt}$  is determined. On the next iteration

$$p = (Sq + Rq' - E)\gamma(t) = (Sa_0 + Sa_1 e^{-bt} - a_1 R b e^{-bt} - E)\gamma(t) = (c e^{-bt} - d)\gamma(t); \quad c = a_1(S - Rb), \quad d = E - Sa_0.$$

The computation on this iteration is performed in two ways:

1) computation for step excitation ( $-d$ ), which has been considered in Example 1; the charge function will be supplemented by a component  $e^{-\frac{S}{R}t}$ ;

2) computation for exponential excitation ( $c e^{-bt}$ ), which will be considered further.

So we are assuming that  $p(t) = \gamma(t) \cdot c e^{-bt}$ . Then  $\overline{p}(\mu) = \frac{c}{\mu + b}$ ,

$F(\mu) = (S + \mu R)(\mu + b)$ ,  $F'(\mu) = (2\mu R + (S + Rb))$ ,  $Z(0) = \infty$  - see

(5.10.7),  $\overline{\Delta q}(\mu) = \frac{\mu \cdot c}{\mu \cdot (S + \mu R)(\mu + b)}$  - see (5.10.4),  $\eta_{1,2} = (-S/R, -b)$ ,

$F'(\eta_{1,2}) = [(Rb - S), (S - Rb)]$ . Therefore  $\Delta q = k e^{-\frac{S}{R}t} + m e^{-bt}$  - see (5.10.6), i.e. on the second way (as on the first one) the charge

function is supplemented by a component  $e^{-\frac{S}{R}t}$ . Here

$$k = \frac{-c}{(Rb - S)}, \quad m = \frac{-c}{(S - Rb)}.$$

**Example 4.** Let us consider a circuit with a sole branch, where  $S=0$ . Let us assume that for it on a certain iteration the current  $q' = a_0 + a_1 e^{-bt}$  is determined. On the next iteration

$$\begin{aligned} p &= (Lq'' + Rq' - E) \cdot \gamma(t) = (-La_1 b e^{-bt} + Ra_0 + Ra_1 e^{-bt} - E) \gamma(t) = \\ &= (c e^{-bt} - d) \gamma(t); \quad c = a_1(R - Lb), \quad d = E - Ra_0. \end{aligned}$$

The computation on this iteration is performed in two ways:

- 1) computation for step excitation  $(-d)$ , which has been considered in Example 1; the charge function will be supplemented by a component  $e^{-\frac{S}{R}t}$ ;
- 2) computation for exponential excitation  $(c e^{-bt})$ , which will be considered further.

So we assume that  $p(t) = \gamma(t) \cdot c e^{-bt}$ . Then  $\bar{p}(\mu) = \frac{c}{\mu + b}$ ,

$$\begin{aligned} F(\mu) &= (R + \mu L)(\mu + b), \quad F'(\mu) = (2\mu L + (R + Lb)), \quad Z(0) = \infty \quad \text{- see} \\ (5.10.7a), \quad \overline{\Delta q'}(\mu) &= \frac{\mu \cdot c}{(R + \mu L)(\mu + b)} \quad \text{- see (5.10.3), } \eta_{1,2} = (-R/L, -b), \end{aligned}$$

$F'(\mu) = [(Lb - R), (R - Lb)]$ . Therefore,  $\Delta q' = k e^{-\frac{R}{L}t} + m e^{-bt}$  - see (5.10.6a), i.e. on the second way (as also on the first) the current

function is supplemented by a component  $e^{-\frac{R}{L}t}$ . Here

$$k = \frac{Rc}{L(Lb - R)}, \quad m = \frac{-bc}{(Lb - R)}.$$

**Case 3.** Let  $p = E \cdot \gamma(t) e^{\lambda \cdot t} \text{Sin}(\omega \cdot t)$ . Then  $\bar{p}(\mu) = \frac{E \cdot \omega}{(\mu - \lambda)^2 + \omega^2}$ .

From (5.10.4) we find

$$\overline{\Delta q}(\mu) = \frac{a \cdot \mu \cdot E \cdot \omega}{\mu \cdot (S + \mu \cdot R + \mu^2 L) ((\mu - \lambda)^2 + \omega^2)}$$

Equation  $F(\mu) = (S + \mu \cdot R + \mu^2 L) ((\mu - \lambda)^2 + \omega^2) = 0$  has the roots  $\eta_{1,2,3,4} = -\alpha \pm j\beta$  and from (5.10.6) we obtain the function of charge increment as a sum of four summands

$$\Delta q = \frac{a \cdot E \omega}{F'(\eta)} e^{\eta t}. \quad (5)$$

**Case 4.** Let  $p = E \cdot \gamma(t) e^{\lambda \cdot t} \text{Cos}(\omega \cdot t)$ . Then  $\bar{p}(\mu) = \frac{E \cdot (\mu - \lambda)}{(\mu - \lambda)^2 + \omega^2}$ .

From (5.10.4) we find

$$\overline{\Delta q}(\mu) = \frac{a \cdot \mu \cdot E(\mu - \lambda)}{\mu \cdot (S + \mu \cdot R + \mu^2 L)(\mu - \lambda)^2 + \omega^2}.$$

As in the preceding cases from (5.10.6) we obtain the function of charge increment as a sum of four summands

$$\Delta q = \frac{a \cdot E \omega (\eta - \lambda)}{F'(\eta)} e^{\eta t}. \tag{6}$$

In the general case the current functions are  $e^{\eta \cdot t} \text{Sin}(\omega \cdot t)$  and  $e^{\eta \cdot t} \text{Cos}(\omega \cdot t)$ . It means that they are interoperable, and so we may use the formulas of Section 3 to compute the current increment on each iteration.

On any iteration of our computation we may encounter any of the considered cases. Therefore, in the general case to the current function 4 summands of exponential type should be added on every iteration. The practice shows that the computation consists of hundreds of iterations. Thus, definite integrals in the formula contain hundreds of summands for each branch. To cut the time and information volume the following technique is suggested. Each exponential is represented as a truncated power series  $\sum_k (\alpha_k + j\beta_k) \cdot t^k$ . So on each iteration and for each charge of the branch the power series of the “former” charge and its increment are summed up, thus not changing the structure and the volume of the charge as a function of time representation.

## 12. Displaced Step Function.

In this case  $f(t) = E \cdot \gamma(t - s)$ , where  $\gamma(t)$  - a step unit,  $s$  - displacement along the time axis. On the first iteration  $p = -E \cdot \gamma(t - s)$ , which follows from (4.15) for  $q=0$ . It is known [14], that  $\gamma(t - s) \cdot d \longrightarrow \frac{d}{\mu} e^{-s \cdot \mu}$ . From the lag theorem it follows that

$$\Delta q(t) = \Delta q_o(t - s) \cdot \gamma(t - s),$$

Where the function  $\Delta q_o(t - s)$  is determined in the same way as for a step function without displacement.



## 13. Multistep Functions

Let us consider a multistep function of the type

$$f(t) = m_k, \quad t = k \cdot \Delta t \div (k + 1) \cdot \Delta t.$$

- see also fig. 1. Evidently, such function may be presented as a sum of displaced step functions. The superposition principle permits to reduce the computation of such function to a multitude of displaced step functions computations.

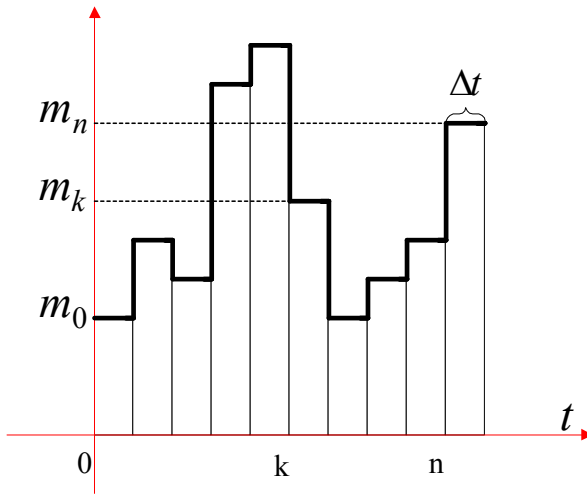

Figure 1. A multi-step function.

## 14. An Exponential on the Positive Time Semiaxis

In this case  $p = E \cdot \gamma(t) e^{\lambda \cdot t}$ . Such a function has been considered above – see (5.11.2, 5.11.3, 5.11.4). In this case these formulas are used on every iteration.

## 15. Trigonometric and Hyperbolic Series on the Positive Time Semiaxis

In this case  $p = E \cdot \gamma(t) \cdot \sum_k [a_k \sin(k\omega t) + b_k \cos(k\omega t)]$  or  $p = E \cdot \gamma(t) \cdot \sum_k [a_k \operatorname{Sh}(k\omega t) + b_k \operatorname{Ch}(k\omega t)]$ . It is known that the functions  $\sin(k\omega t)$ ,  $\cos(k\omega t)$ ,  $\operatorname{Sh}(k\omega t)$ ,  $\operatorname{Ch}(k\omega t)$  may be presented as a sum of two exponentials. Thus this case is brought to the preceding case.

# Chapter 6. Variational Principle and Maximum Principle

---

## 1. Introduction to Maximum Principle

Let us examine now some concepts of the Pontryagin's maximum principle [18] in view of its future application.

Let us consider a functional

$$F = \int_0^T f_0(x, u) dt, \quad (1)$$

of the equations system

$$\frac{dx_i}{dt} = f_i(x, u), \quad (2)$$

$$\frac{d\psi_i}{dt} = -\frac{\partial f_0(x, u)}{\partial x_i} - \sum_{v=1}^n \frac{\partial f_v(x, u)}{\partial x_i} \psi_v, \quad (3)$$

the function

$$H(\psi, x, u) = f_0(x, u) + \sum_{v=1}^n \psi_v \cdot f_v(x, u), \quad (4)$$

with respect to vector-functions of time

$$x^T = x_1, x_2, \dots, x_n,$$

$$\psi^T = \psi_1, \psi_2, \dots, \psi_n,$$

$$u^T = u_1, u_2, \dots, u_m.$$

It is significant that these functions may be discontinuous, and their range of values may be limited. The maximum principle lies in the fact that the search for functional's (1) minimum by  $x(t)$ ,  $u(t)$  may be replaced by the search for the function's (4) maximum by  $u$  in all the points of time interval.

Later on our main interest will be in the case when

$$\frac{dx_i}{dt} = u_i. \quad (6)$$

Then also

$$\frac{d\psi_i}{dt} = -\frac{\partial f_0(x, u)}{\partial x_i}, \quad (7)$$

$$H(\psi, x, u) = f_0(x, u) + \sum_{v=1}^n \psi_v \cdot u_v. \quad (8)$$

**Example 1.** Let

$$F = \int_0^T (Sx^2 - Lu^2 - Ex) dt.$$

Then from (7) and (8) we shall get

$$\frac{d\psi}{dt} = -2Sx + E,$$

$$H(\psi, x, u) = (Sx^2 - Lu^2 - Ex) + \psi \cdot u.$$

The necessary condition of the last function's maximum максимума by variable  $u$  is:

$$\frac{\partial}{\partial u} [H(\psi, x, u)] = 0$$

or

$$-2Lu + \psi = 0.$$

Taking into account (6) and using the notations of section 2.1, we get the necessary condition of maximum

$$-2Lx' - 2S\hat{x} + \hat{E} = 0.$$

This condition should not change with passing from one point of time to another. Consequently,

$$\frac{d}{dt} (-2Lx' - 2S\hat{x} + \hat{E}) = 0$$

or

$$2Lx'' + 2Sx - E = 0.$$

Notice that if (6) is valid, then the necessary condition of the initial functional's minimum is the same. So, we have discovered the condition of the initial functional's minimum by using the maximum principle.

Considering the example 1, it is important to note that:

- the necessary optimum condition of the initial functional's minimum may be obtained only on the condition that the

integrand function is differentiable, and therefore the function  $E(t)$  has no discontinuities;

- the necessary condition of maximum is obtainable for any function  $E(t)$ ;
- formally, the above named conditions coincide; thus, the maximum principle permits to extend the condition of the initial functional's for discontinuous functions  $E(t)$ .

Nevertheless the problem of the method of solution of the equation, representing the necessary condition of the initial functional's minimum or the necessary maximum condition, is still an open question. We have considered above a method based on gradient descent along the functional. Now we shall show a method based on gradient ascent along the maximized function  $H(t)$ .

Converting to vector and matrix notations, from (6, 7, 8) we get

$$\frac{dx}{dt} = u, \tag{9}$$

$$\frac{d\psi}{dt} = -\frac{\partial f_0(x, u)}{\partial x}, \tag{10}$$

$$H(\psi, x, u) = f_0(x, u) + \psi^T \cdot u. \tag{11}$$

## 2. Maximization Method

Let us consider now the following

### Maximization algorithm 1.

1. Assume that  $x(t) \equiv 0$  and  $u(t) \equiv 0$ .

2. Compute  $\psi'(t) = -\frac{\partial f_0(x, u)}{\partial x}$ .

3. Compute  $\psi(t) = \int_0^t \psi'(\tau) \cdot d\tau$  with known  $\psi'(0)$ .

4. Determine the function  $H(\psi, u)$  using (11) with known  $\psi(t), x(t)$ .

5. Compute  $u(t)$  from the condition  $\frac{\partial}{\partial u} [H(\psi, u)] = 0$ .

6. Check the variation of function  $u(t)$  compared with its previous value and, if it is sufficiently small, stop the computation.

7. Compute  $x(t) = \int_0^t u(\tau) \cdot d\tau$  with known  $u(0)$ .
8. Go to p. 2.

**Example 2.** Let

$$F = \int_0^T (Sx^2 - Lu^2 - E \cdot \gamma(t) \cdot x) dt,$$

where  $E$  – a constant,  $\gamma(t)$  – jump unit. Let us use the maximization algorithm. On *the first iteration*

1. Assume that  $x(t) \equiv 0$  and  $u(t) \equiv 0$ .
2. Compute  $\psi'(t) = -2Sx + E\gamma(t) = E\gamma(t)$ .
3. Compute  $\psi(t) = E \int_0^t \gamma(\tau) \cdot d\tau = E \cdot t$ .
4. From (11) determine the function  $H(t, u) = -Lu^2 + E \cdot t \cdot u$ , where the items, not dependent on  $u$ , are discarded.
5. Compute  $u(t)$  from the condition  $-2Lu + Et = 0$ . We have  $u(t) = \frac{E}{2L}t$ .
6. Check the variation of function  $u(t)$  and continue the calculation.
7. Compute  $x(t) = \int_0^t u(\tau) \cdot d\tau = \frac{E}{4L}t^2$ .

Go to *the second iteration*.

2. Compute  $\psi'(t) = -2Sx + E\gamma(t) = -\frac{SE}{2L}t^2 + E\gamma(t)$ .
3. Compute  $\psi(t) = E \int_0^t \left( -\frac{S}{2L}t^2 + \gamma(\tau) \right) \cdot d\tau = E \cdot \left( -\frac{S}{6L}t^3 + t \right)$ .
4. Determine the function  $H(t, u) = -Lu^2 + \psi(t) \cdot u$  or  $H(t, u) = -Lu^2 + E \left( -\frac{S}{6L}t^3 + t \right) \cdot u$ .
5. Compute  $u(t)$  from the condition  $-2Lu + E \left( -\frac{S}{6L}t^3 + t \right) = 0$ .  
We have  $u = \frac{E}{2L} \left( -\frac{S}{6L}t^3 + t \right)$ .
6. Check the variation of  $u(t)$ , and continue the calculation.

$$7. \text{ Compute } x(t) = \int_0^t u(\tau) \cdot d\tau = \frac{E}{4L} \left( \frac{-S}{12L} t^4 + t^2 \right).$$

Go to the third iteration.

$$2. \text{ Compute } \psi'(t) = -2Sx + E\gamma(t) = -\frac{SE}{2L} \left( \frac{-S}{12L} t^4 + t^2 \right) + E\gamma(t).$$

$$3. \text{ Compute } \psi(t) = \left\{ E \int_0^t \psi'(\tau) \cdot d\tau = -\frac{SE}{6L} \left( \frac{-S}{20L} t^5 + t^3 \right) + Et \right\}.$$

4. Determine the function  $H(t, u) = -Lu^2 + \psi(t) \cdot u$  or

$$H(t, u) = -Lu^2 + \left( -\frac{SE}{6L} \left( \frac{-S}{20L} t^5 + t^3 \right) + Et \right) \cdot u.$$

$$5. \text{ Determine } u(t). \text{ We have } u = -\frac{SE}{12L^2} \left( \frac{-S}{20L} t^5 + t^3 \right) + \frac{E}{2L} t.$$

6. Check the function's variation  $u(t)$  and continue the computation.

$$7. \text{ Compute } x(t) = \int_0^t u(\tau) \cdot d\tau = -\frac{SE}{48L^2} \left( \frac{S}{30L} t^6 + t^4 \right) + \frac{E}{4L} t^2.$$

Thus, as the result of the iterations we consequently get

$$x_1(t) = \frac{E}{4L} t^2,$$

$$x_2(t) = \frac{E}{4L} \left( t^2 - \frac{S}{12L} t^4 \right),$$

$$x_3(t) = \frac{E}{4L} \left( t^2 - \frac{S}{12L} t^4 + \frac{S^2}{360L^2} t^6 \right) \dots$$

So we may conclude that

$$x(t) = \frac{E}{4S} \left( \beta t^2 - \frac{\beta^2}{12} t^4 + \frac{\beta^3}{360} t^6 - \dots \right),$$

where  $\omega = \sqrt{\frac{S}{L}}, \beta = \omega^2 = \frac{S}{L}$ , or

$$x(t) = \frac{E}{2S} \left( \frac{(\omega t)^2}{2!} - \frac{(\omega t)^4}{4!} + \frac{(\omega t)^6}{6!} - \dots \right).$$

Therefore,

$$x(t) = \frac{E}{2S} (\text{Cos}(\omega t) - 1).$$

The condition of the initial functional's minimum and the condition of maximum are (as was shown in the Example 1) as follows:

$$2Lx'' + 2Sx - E = 0.$$

Substituting  $x(t)$  and  $x''(t) = \frac{-\omega^2 E}{2S} \text{Cos}(\omega t)$  into this condition, we get an identity, which testifies that the computations were correct.

**Example 3.** Let us assume that in the example 2 on one of the iterations we got

$$x(t) = E \sum_{k=1}^n a_k (\omega t)^{2k}, \text{ where } a_k = \frac{1}{2S \cdot (2k)}.$$

Then

2. Compute  $\psi'(t) = -2Sx + E\gamma(t) = -2SE \sum_{k=1}^n a_k (\omega t)^{2k} + E\gamma(t).$

3. Compute  $\psi(t) = E \left( -2S \sum_{k=1}^n \frac{a_k}{(2k+1)\omega} (\omega t)^{2k+1} + t \right).$

5. Compute  $u(t)$  according to the formula  $u(t) = \frac{1}{2L}\psi(t)$ , which follows from the maximization condition (8).

7. Compute

$$x(t) = \int_0^t u(\tau) \cdot d\tau = E \left( \frac{-S}{L} \sum_{k=1}^n \frac{a_k}{(2k+1)(2(k+1))\omega^2} (\omega t)^{2(k+1)} + \frac{t^2}{4L} \right)$$

or

$$x(t) = E \sum_{k=1}^{n+1} b_k (\omega t)^{2k}, \text{ где } b_1 = \frac{t^2}{4L}, \text{ } b_k = \frac{S a_{k-1}}{L(2k-1)(2k)\omega^2}.$$

Taking into account that  $a_1 = \frac{1}{2S}$  and (as was shown in Example 2)

$\omega^2 = \frac{S}{L}$ , find finally that  $b_k = a_k$ . Thus, on every iteration the series of function  $x(t)$  is supplemented by item number  $(n+1)$ .



### 3. Second Order Differential Equations Systems with Step Excitations

Let us consider an RCL-circuit with electric charges and the functional (1.1, 1.2). We shall denote:  $x'(t) = u_x(t)$ ,  $y'(t) = u_y(t)$ . Then this functional will be written as follows:

$$F = \int_0^T f_0(x, y, u_x, u_y) dt, \quad (12)$$

RAE

$$f_0(x, y, u_x, u_y) = \left( S(x^2 - y^2) - L(u_x^2 - u_y^2) + R(xu_y - u_x y) - E(x - y) \right). \quad (13)$$

We shall assume that the unknown functions in this functional are  $x(t)$ ,  $u_x(t)$ . Then according to (7), (8) we shall get accordingly

$$\frac{d\psi_x}{dt} = -2Sx - Ru_y + E, \quad (14)$$

$$H(\psi_x, x, u_x) = f_0(\dots) + \psi_x \cdot u_x. \quad (16)$$

The condition of the last function's maximum with respect to  $u_x(t)$  after discarding the items not dependent on  $u_x(t)$  will become:

$$-2Lu_x - Ry + \psi_x = 0,$$

So the optimal value of the function  $u_x(t)$  may be determined as

$$u_x = \frac{1}{2L}(\psi_x - Ry) = 0. \quad (17)$$

This means that *maximization* of the function (16) is equivalent to *minimization* of the initial functional with respect to the function  $x(t)$ .

The functions

$$\frac{d\psi_y}{dt} = 2Sy + Ru_x - E \quad (18)$$

$$H(\psi_x, x, u_x) = f_0(\dots) + \psi_x \cdot u_x. \quad (19)$$

may be found in the same way, as well as the optimal value of function  $u_x(t)$ , which gives the minimum of the function (19):

$$u_y = \frac{-1}{2L}(\psi_y + Rx) = 0. \quad (20)$$

So it is shown that *minimization* of the function (19) is equivalent to *maximization* of the initial functional with respect to function  $y(t)$ .

We shall use now the maximization algorithm 1 for finding the function  $x(t)$ . In this particular case we have

**Maximization algorithm 2**

1. Assume that  $x(t) \equiv 0$  and  $u_x(t) \equiv 0$ .
2. Compute according to (14)  $\psi'_x = -2Sx - Ru_y + E$ .
3. Compute  $\psi_x(t) = \int_0^t \psi'_x(\tau) \cdot d\tau$  with known  $\psi'(0)$ .
4. Compute according to (17)  $u_x = \frac{1}{2L}(\psi_x - Ry)$ .
5. Check the variation of function  $u(t)$  compared with its previous value, and, if it is sufficiently small, stop the computation.
6. Compute  $x(t) = \int_0^t u(\tau) \cdot d\tau$  with known  $u(0)$ .
7. Go to p. 2.

The maximization algorithm for finding the function  $y(t)$  will be similar to the one we described above. We shall perform the algorithms for maximization of  $x(t)$  and  $y(t)$  simultaneously. It means that after performing an iteration for the two algorithms, we shall substitute the values of functions  $x$ ,  $u_x$ , found in the first algorithm, to the formulas of the second algorithm, and the values of  $y$ ,  $u_y$ , found in the second algorithm we shall substitute to the formulas of the first algorithm. It is easy to see that on the iterations with the same numbers the following conditions are fulfilled:

$$x = y, \quad u_x = u_y, \quad \psi_x = -\psi_y. \tag{21}$$

Let us denote similarly to (1.8)

$$q = x + y, \quad u = u_x + u_y, \quad \psi = \psi_x = -\psi_y. \tag{22}$$

From the above it follows that the charge  $q$  may be computed with the aid of the following algorithm.

**Maximization algorithm 3.**

1. Assume that  $q(t) \equiv 0$  и  $u(t) \equiv 0$ .
2. Compute  $\psi' = -Sq - \frac{1}{2}Ru + E$ .

3. Compute  $\psi(t) = \int_0^t \psi'(\tau) \cdot d\tau$  with known  $\psi'(0)$ .
4. Compute  $u = \frac{1}{L} \left( \psi - \frac{1}{2} Rq \right)$ .
5. Check the variation of function  $u(t)$  compared to its previous value, and if it is sufficiently small, stop the computation.
6. Compute  $q(t) = \int_0^t u(\tau) \cdot d\tau$  with known  $u(0)$ .
7. Go to p. 2

Evidently, the maximization algorithm 3 is usable only in the case when  $L > 0$ . (23)

**Example 4.** Let the voltage of a RCL-circuit be equal to  $E \cdot \gamma(t)$ , where  $E$  – is a constant,  $\gamma(t)$  – jump unit. We shall use now the maximization algorithm. On *the first iteration*

1. Assume that  $q(t) \equiv 0$  and  $u(t) \equiv 0$ .
2. Compute  $\psi'(t) = -Sq - \frac{1}{2}Ru + E\gamma(t) = E\gamma(t)$ .
3. Compute  $\psi(t) = \int_0^t \psi'(\tau) \cdot d\tau = Et$
4. Compute  $u = \frac{1}{L} \left( \psi - \frac{1}{2}Rq \right) = \frac{E}{L}t$ .
5. Compute  $q(t) = \int_0^t u(\tau) \cdot d\tau = \frac{E}{2L}t^2$ .

On *the second iteration*

2. Compute  $\psi'(t) = -Sq - \frac{1}{2}Ru + E\gamma(t) = -\frac{SE}{2L}t^2 - \frac{ER}{2L}t + E\gamma(t)$ .
3. Compute  $\psi(t) = -\frac{SE}{6L}t^3 - \frac{RE}{4L}t^2 + Et$
4. Compute  $u = \frac{1}{L} \left( \psi - \frac{1}{2}Rq \right) = -\frac{SE}{6L^2}t^3 - \frac{RE}{2L^2}t^2 + \frac{E}{L}t$ .
5. Compute  $q(t) = \int_0^t u(\tau) \cdot d\tau = -\frac{SE}{24L^2}t^4 - \frac{RE}{6L^2}t^3 + \frac{E}{2L}t^2$ .

Let us assume that on *a particular iteration* we got:

$$q(t) = E \sum_{k=1}^n a_k t^k, \quad u(t) = E \sum_{k=1}^n b_k t^k.$$

Then

1. Compute

$$\psi'(t) = -Sq - \frac{1}{2}Ru + E\gamma(t) = -E \sum_{k=1}^n c_k t^k + E\gamma(t),$$

$$c_k = \left( Sa_k + \frac{1}{2}Rb_k \right).$$

2. Compute  $\psi(t) = E \left( - \sum_{k=1}^n \frac{c_k}{k+1} t^{k+1} + t \right)$ .

3. Compute

$$\begin{aligned} u(t) &= \frac{1}{L} \left( \psi - \frac{1}{2}Rq \right) = \frac{E}{L} \left( - \sum_{k=1}^n \frac{c_k}{k+1} t^{k+1} + t \right) - \frac{ER}{2L} \sum_{k=1}^n a_k t^k = \\ &= E \left( -a_1 t - \sum_{k=1}^n \left( \frac{c_k}{L(k+1)} + \frac{Ra_{k+1}}{2L} \right) t^{k+1} + \frac{t}{L} \right) = E \left( \sum_{k=1}^{n+1} b_k t^k \right), \\ b_1 &= \left( -a_1 + \frac{1}{L} \right), \quad b_{k>1} = \left( \frac{-c_{k-1}}{Lk} - \frac{Ra_k}{2L} \right). \end{aligned}$$

4. Compute

$$q(t) = \int_0^t u(\tau) \cdot d\tau = E \left( \sum_{k=2}^{n+2} \frac{b_{k-1}}{k} t^k \right).$$

We see that on each iteration the series of the function  $q(t)$  is supplemented by two items.

**Example 5.** To test the solution obtained in the example 4, let us consider the equation, given in the example 5.1. It was shown there that that the general solution of this equation is as follows:

$$q = \frac{Ee^{-\alpha t}}{S \cdot \beta} (-\beta \cdot \text{Cos}(\beta t) - \alpha \cdot \text{Sin}(\beta t)) + \frac{E}{S},$$

where  $\alpha = \frac{R}{2L}$ ,  $\beta = \frac{\sqrt{4LS - R^2}}{2L}$ . Let us build a Maclaurin series of this function:

$$q(t) = \frac{E}{S} \left( \frac{(\alpha^2 + \beta^2)}{2} t^2 - \frac{2\alpha(\alpha^2 + \beta^2)}{3!} t^3 - \frac{(\alpha^2 + \beta^2)^3}{4!} t^4 - \dots \right)$$

As  $(\alpha^2 + \beta^2) = \frac{S}{L}$ , the obtained expression is similar to one obtained on the second iteration of the example 4, which proves the statement.

It may be noted that the presented algorithm is applicable also for vector variables, where  $L$ ,  $S$ ,  $R$  are quadratic matrices. What matters is only that the electric circuit is wholly described by the equations system

$$Sx + Rx' + Mx'' = E(t), \quad (24)$$

**Example 6.** Consider the program realizing maximization algorithm 3 for solving the equations system (24) for  $E(t) = E\gamma(t)$  in the MATLAB system. This program consists of the following M-functions:

- ValueSeries** – computing the value of power series vector,
- DifSeries** – differentiation of power series vector,
- IntegraSeries** – integration of power series vector,
- errtio** – computing the error for a given moment,
- DEjump** – main function.

Consider the main function **DEjump**. It computes the power series of the functions  $x$ ,  $x'$ ,  $x''$ . It is assumed that the function should be defined on the observation interval  $0 \leq t \leq T$ . The computation results in forming the following matrix, for representation of function  $x(t)$ :

$$x(t) = \begin{pmatrix} x_1(t) \\ \dots \\ x_k(t) \\ \dots \\ x_d(t) \end{pmatrix} \Rightarrow \begin{pmatrix} x_{1,1} & \dots & x_{1,n} & \dots & x_{1,N} \\ \dots & \dots & \dots & \dots & \dots \\ x_{k,1} & \dots & x_{k,n} & \dots & x_{k,N} \\ \dots & \dots & \dots & \dots & \dots \\ x_{d,1} & \dots & x_{d,n} & \dots & x_{d,N} \end{pmatrix},$$

where element  $x_k(t)$  of vector-function  $x(t)$  is a polynomial

$$x_k(t) = \sum_{n=1}^N x_{k,n} \cdot t^n \text{ and is represented by a row of values } x_k(t) \text{ in}$$

the observation moments.

The following parameters are used in this program:

*input:*

S, M, R, E – see above,

N – maximal number of the series terms,

erToler – minimal tolerant error at the end of observation

interval,

*output:*

$x$ ,  $x1 = x'$ ,  $x2 = x''$  - see above,

tio=T – observation interval,

err – computed error at the end of observation interval,

er – residual vector in the equation (24), also represented by power series.

The computation is performed iteratively. In the process of computation a series is formed, with number of terms twice the number of iterations. Simultaneously the size of maximal observation interval  $T$  (tio), on which the relative error is less than the given tolerant value (erToler), is computed.

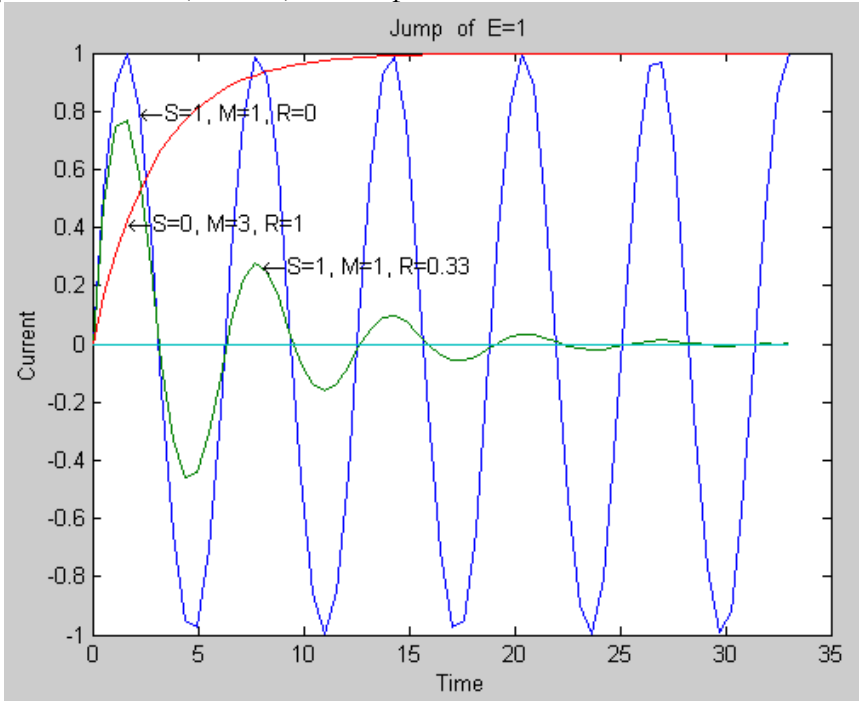

For large N it may occur, that the value  $T^N$  exceeds the bounds of the processor capacity. It may be revealed by the fact that the functions graphs are truncated before reaching the end of observation interval. In this case the number N should be reduced.

The figure (see function testDEJ\_2) depicts the results of

computation, using this function, of three independent equations, where

$$\begin{aligned} S &= [1, 0, 0; 0, 1, 0; 0, 0, 0]; \\ R &= [0, 0, 0; 0, 0.33, 0; 0, 0, 1]; \\ M &= [1, 0, 0; 0, 1, 0; 0, 0, 3]; \\ E &= [1; 1; 1]; \end{aligned}$$

We shall now look more carefully at the maximization algorithm 3. Combining the formulas of this algorithm and taking into account that at the end of iteration process  $q'(t) = u(t)$ , we get the formula for the charge:

$$q(t) = \int_0^t \frac{1}{L} \left( -\frac{1}{2} Rq(\tau) + \int_0^\tau \left( -Sq(\vartheta) - \frac{1}{2} Rq'(\vartheta) + E(\vartheta) \right) d\vartheta \right) d\tau.$$

Differentiating twice, we find

$$q''(t) = \frac{1}{L} (-Rq' - Sq + E),$$

That means that at the end of iteration process the equation of RCL-circuit is fulfilled.

### About overflow

For large  $N$  it may occur, that the value  $T^N$  exceeds the bounds of the processor capacity. It may be revealed by the fact that the functions' graphs are truncated before reaching the end of observation interval. In this case the value of  $N$  should be reduced (see also function `testDEjump4`).

### About convergence

Independent of the matrices' form there exists computational convergence, which implies that on a given observation interval the form of the sought functions does not depend on the length of series (recall: the length of series should be extended only with the aim of extending the observation interval).

However, for ill determined matrices the solution diverges – the functions grow infinitely. At the same time the computational convergence still holds. Recall, that in our case the term “well determined matrices” means positive semi determined matrices  $S$ ,  $R$  and a positive determined matrix ( $M \neq 0$ ). For  $M = 0$  the solution does not exist. In the next section we shall withdraw this condition (see also functions `testEDJconv`, `testEDJconv2`).

In our presentation context this algorithm is remarkable because it shows that *the maximum principle of functional (1.1, 1.2) may be extended for discontinuous functions*. From this and from Theorem 4.1.1 follows

**Statement 1.** The functional (4.1.12) and the equation (4.1.13) may contain discontinuous functions  $E(t)$ . For them the Theorem 4.1.1 is valid, and the equation of the functional's stationary value (4.1.12) takes the form (4.1.13).

This statement has been used above in the description of discontinuous function computation method. Further we shall deal with the problems of its application for electric circuits computation.

## 4. First Order Differential Equations Systems with Step Excitations

Let us consider RCL-circuit with electrical currents and functional (2.6, 2.7). Let us denote:

$$V = \hat{v}, \quad v = V' = u_v, \quad W = \hat{w}, \quad w = W' = u_w. \quad (25)$$

Then this functional for  $L=0$  will assume the form

$$F = \int_0^T f_o(V, W, u_v, u_w) dt, \quad (26)$$

where

$$f_o(V, W, u_v, u_w) = \left\{ \begin{array}{l} S(u_v W - V u_w) + \\ + R(u_v^2 - u_w^2) - E(u_v - u_w) \end{array} \right\}. \quad (27)$$

We shall assume that in the functional the unknown functions are  $V(t)$ ,  $u_v(t)$ . Then in accordance to (7), (8) we shall get accordingly

$$\frac{d\psi_v}{dt} = S u_w, \quad (28)$$

$$H(\psi_v, V, u_v) = f_o(\dots) + \psi_v \cdot u_v. \quad (29)$$

The maximum condition of the last function  $u_v(t)$  after discarding the terms that do not depend on  $u_v(t)$ , will assume the form

$$S W + 2R u_v - E + \psi_v = 0,$$

and from this condition the optimal value of  $u_v(t)$  may be determined:



откуда определяется оптимальное значение функции  $u_v(t)$ :

$$u_v = \frac{1}{2R}(E - S \cdot W - \psi_v). \quad (30)$$

So, *maximization* of function (29) is equivalent to *minimization* of the initial functional  $V(t)$ .

In the same way we may determine the functions

$$\frac{d\psi_w}{dt} = -Su_v, \quad (31)$$

$$H(\psi_w, W, u_w) = f_0(\dots) + \psi_w \cdot u_w. \quad (32)$$

The maximum condition of the last function  $u_w(t)$  will take the form

$$-SV - 2Ru_w + E + \psi_v = 0,$$

and the optimal value of  $u_w(t)$ , for which the function (32) will be maximized, is,

$$u_w = \frac{1}{2R}(E - S \cdot V + \psi_w). \quad (33)$$

So, *minimization* of the function (32) is equivalent to *maximization* of the initial functional with respect to the function  $W(t)$ .

Let us now use algorithm 1 for the search of function  $V(t)$ . In this particular case we have

**Maximization Algorithm 4**

1. Assume that  $u(t) = \frac{E}{2R}$  and compute  $V(t) = \int_0^t u_v(\tau) \cdot d\tau$ .
2. Compute by (31)  $\psi'_v = S \cdot u_w$ .
3. Compute  $\psi_x(t) = \int_0^t \psi'_x(\tau) \cdot d\tau$ .
4. Compute by (33)  $u_v = \frac{1}{2R}(E - S \cdot W - \psi_v)$ .
5. Check the increment of  $u_v(t)$  comparing with the previous value, and if it is small enough, stop the computation.
6. Compute  $V(t) = \int_0^t u_v(\tau) \cdot d\tau$ .
7. Go to p. 2.

The maximization algorithm for function  $W(t)$  is similar. We shall now perform the maximization algorithms for  $V(t)$  and  $W(t)$  synchronously. This means that after performing the iteration at hand by both algorithms we shall substitute the values of  $V$ ,  $u_v$  obtained by the first algorithm in the formulas of the second algorithm, and the values  $W$ ,  $u_w$ , obtained by the second algorithm will be substituted in the formulas of the first algorithm. It is easy to see that on iterations with the same number the following conditions are fulfilled:

$$V = W, \quad u_v = u_w, \quad \psi_v = -\psi_w. \quad (34)$$

Let us denote similarly (2.5)

$$q = V + W, \quad u = u_v + u_w, \quad \psi = \psi_v = -\psi_w. \quad (35)$$

From the previous it follows that the charge  $q$  may be computed by the following algorithm.

**Maximization Algorithm 5**

1. Assume that  $u(t) = \frac{E}{R}$  and compute  $q(t) = \int_0^t u(\tau) \cdot d\tau$ .
2. Compute  $\psi' = \frac{1}{2} S \cdot u$ .
3. Compute  $\psi(t) = \int_0^t \psi'(\tau) \cdot d\tau$  with known  $\psi'(0)$ .
4. Compute  $u = \frac{1}{R} \left( E - \frac{1}{2} S \cdot q - \psi \right)$
5. Check the increment of  $u(t)$  comparing with the previous value, and if it is small enough, stop the computation.
6. Compute  $q(t) = \int_0^t u(\tau) \cdot d\tau$ .
7. Go to p. 2.

It is evident that the maximization algorithm 5 is applicable only in the case when

$$R > 0. \quad (36)$$

Notice that pp. 2-3 may be combined, and then this algorithm becomes simpler and assumes the following form:

**Maximization Algorithm 6**

1. Assume that  $u(t) = \frac{E}{R}$  and compute  $q(t) = \int_0^t u(\tau) \cdot d\tau$ .
2. Compute  $u = \frac{1}{R}(E - S \cdot q)$
3. Check the increment of  $u(t)$  comparing with the previous value, and if it is small enough, stop the computation.
4. Compute  $q(t) = \int_0^t u(\tau) \cdot d\tau$ .
5. Go to p. 2.

From the remark 2.1 it follows that this algorithm is applicable also in the case when  $R$  is a function  $R(t)$  of independent variable  $t$ .

If the functions are presented as series of the form

$$u = \sum_{k=1}^n u_k, \quad q = \sum_{k=1}^n q_k,$$

where  $n$  is the iteration number, then Algorithm 6 takes the following form:

**Maximization algorithm 7.**

1. Fix  $n = 1$ , compute  $u_1(t) = \frac{E}{R}$  and compute  $q_1(t) = \int_0^t u_1(\tau) \cdot d\tau$ .
2. Compute  $u_{n+1}(t) = -\frac{S}{R}q_n(t)$
3. Check the function  $u(t)$  variation compared with the previous  $n$ , and if it is small enough, stop the computation.
4. Compute  $q_{n+1}(t) = \int_0^t u_{n+1}(\tau) \cdot d\tau$ .
5. Raise  $n$  by 1 and go to p.. 2.

**Example 7.** Let us consider the equation

$$Sq + Rq' - E\gamma(t) = 0, \tag{a}$$

where  $E$  is constant,  $\gamma(t)$  - unit step. The solution of this equation is

$$q' = \frac{E}{R} \left( \gamma - 1 + \exp\left(-\frac{S}{R}t\right) \right). \text{ Note that}$$

$$q = \int_0^t q' \cdot d\tau = \frac{E}{R} \left( \int_0^t \exp\left(-\frac{S}{R}\tau\right) \cdot d\tau \right) = -\frac{E}{S} \left( \int_0^t \exp\left(-\frac{S}{R}\tau\right) \right),$$

i.e.

$$q = \frac{E}{S} \left( 1 - \exp\left(-\frac{S}{R}t\right) \right).$$

The solution of equation (a) for  $t > 0$  has the form

$$q' = \frac{E}{R} \exp\left(-\frac{S}{R}t\right). \tag{B}$$

$$q = \frac{E}{S} \left( 1 - \exp\left(-\frac{S}{R}t\right) \right). \tag{C}$$

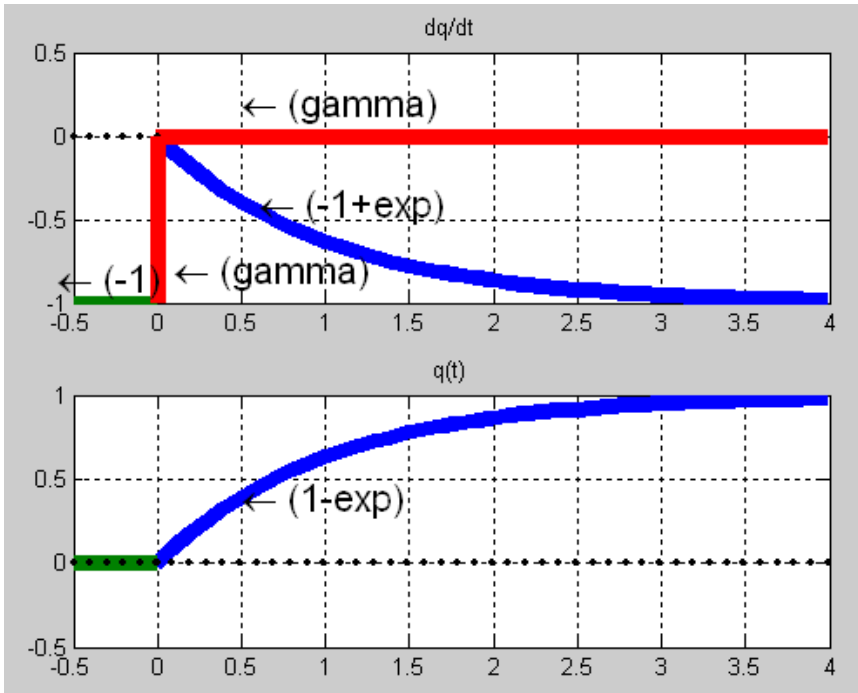

Fig. 1.

For  $t \rightarrow 0$  we have

$$q' \rightarrow \frac{E}{R}, \quad q \rightarrow 0, \quad (\text{A})$$

But at the moment  $t = 0$  the derivative exhibits a jump

$$q'(0) = \frac{E}{R} \gamma \quad (\text{e})$$

By direct substitution into the initial equation we can ascertain that the solution is correct – see Fig. 1 and also function FigGamma).

For the solution of equation (a) we shall use the optimization algorithm 7.

0. Begin with  $q(t) = 0$ .

1. Compute  $u(t) = u_1(t) = \frac{E\gamma(t)}{R}$  and compute

$$q(t) = q_1(t) = \int_0^t u_1(\tau) \cdot d\tau = \frac{E}{R} t.$$

2. Then compute consequently

$$u_2 = -\frac{S}{R} q_1 = -\frac{SE}{R^2} t, \quad q_2(t) = \int_0^t u_2(\tau) \cdot d\tau = -\frac{SE}{2R^2} t^2,$$

$$u_3 = -\frac{S}{R} q_2 = \frac{S^2 E}{2R^3} t^2, \quad q_3(t) = \int_0^t u_3(\tau) \cdot d\tau = \frac{S^2 E}{6R^3} t^3,$$

$$u_4 = -\frac{S}{R} q_3 = -\frac{S^3 E}{6R^4} t^3, \quad q_4(t) = \int_0^t u_4(\tau) \cdot d\tau = -\frac{S^3 E}{24R^3} t^4$$

and so on. Thus,  $q(t) = \frac{E}{S} \left( \frac{S}{R} t - \frac{S^2}{2R^2} t^2 + \frac{S^3}{6R^3} t^3 - \dots \right)$ .

Notice that on each iteration one term is added to the series of the function  $q(t)$ . Also notice that when the number of iterations grows,  $q(t)$  approaches the known result:

$$q(t) \rightarrow \frac{E}{S} \left( 1 - \exp\left(-\frac{S}{R} t\right) \right), \text{ which was to be proved.}$$

It can be seen that the proposed algorithm may be applied also to the case of vector variables, where  $S$ ,  $R$  are quadratic matrices. What matters is only that the electric circuit is fully described by the equations system

$$Sq + Rq' = E(t). \tag{37}$$

**Example 8.** Consider the program realizing maximization algorithm 3 for solving the equations system (37) with  $E(t) = E\gamma(t)$ . This program is similar to the program of example 6 and it uses the same notations and the same subsidiary functions. Only the main function is different: DEjumpRC. The following figure shows (see also function testDEJRC\_127) the result of computation with the aid of this program of a system of 127 equations. The figure shows the graphs of  $x(t)$ ,  $x'(t)$  for three functions with numbers 1, 52, 113.

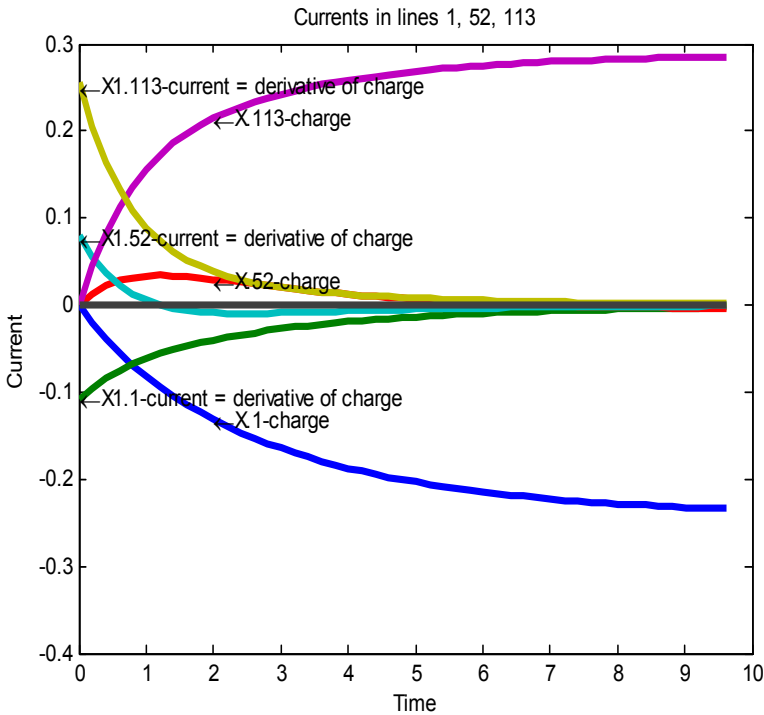

Some other examples are considered in 9.6.6.

## 5. Differential Equations Systems with Multi-step Excitations

In the above (in section 6.4) considered case the voltages of the circuit are of the form  $\bar{E}(t) = \bar{E}_o \cdot \gamma(t)$ , where  $\bar{E}_o$  – a constant vector,  $\gamma(t)$  – a jump unit. In the beginning of each iteration the value  $\psi'(t) = -\bar{S}q - \frac{1}{2}\bar{R}u + \bar{E}_o\gamma(t)$  is being computed, and, consequentially,

the item is added to the function  $\bar{E}_o t$ . So on each iteration of the maximization algorithm 3 the power series of the function  $q(t)$  is supplemented by two items. However we shall not go beyond a certain number of series members, because the series are convergent.

The above presented example 4 illustrates this case.

Evidently, the same algorithm may be applied also for the function  $\bar{E}(t) = \bar{E}_o \cdot \gamma(t - t_o)$ , where  $t_o > 0$  – a certain moment. The same algorithm is applicable in the case, when the function can be presented in the form

$$\bar{E}(t) = \sum_{i=1}^h \bar{E}_{io} \cdot \gamma(t - t_{io})$$

- see example fig. 1. According to the superposition principle for electric circuits, the computation consists in multiple use of the maximization algorithm 3.

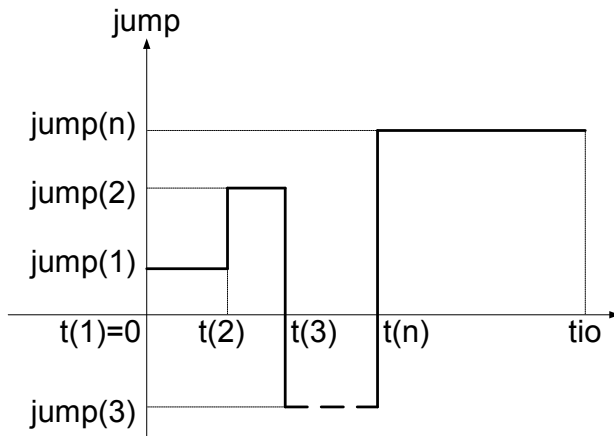

Fig. 1.

**Example 9.** Consider `DEjumpMany`, which realizes maximization algorithm 3 for step voltages. In this function the following parameters will be used

*input:*

`S`, `V`, `R`, `erToler`, `N` – see above in `Dejump` function description,  
`EE` – vector with all the components except one are equal to zero, and the non-zero component is  $e = 1$ ,

`jump` – vector of voltage jumps of the non-zero component  $e$ ,  
`jump` = [`jump`(1), `jump`(2), ..., `jump`(n)],

`tjump` – vector of the jump moments,

`tjump` = [`t1`=0, `t2`, `t3`, ..., `tn`, 999],

`pixels` – number of observation points on the observation interval

*output:*

`tio`=`T`, `err` - see above in `Dejump` function description,

`xt`, `x1t`, `x2t` – the unknown functions,

`t` – the moments of these functions' observation

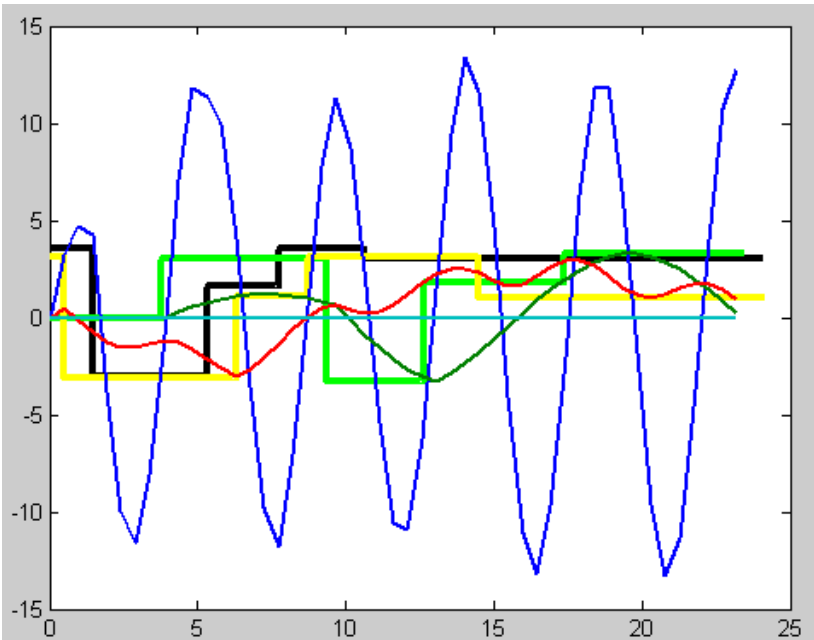

Fig. 1 illustrates the meaning of notations used for some variables in this function. On the output of `DEjumpMany` function the matrices of the values of the unknown functions in all points of observation are formed. The figure shows the solution results of a certain system of three equations with multiple step excitations - see also function `testDEJmany`.



## 6. First Order Differential Equations Systems with Excitations in the Form of Dirac Functions

Further we shall discuss a Dirac function  $\gamma'(t)$ . Between the truncated Dirac function  $\gamma'(t)$  and the step function  $\gamma(t)$  the following correlations are formed:

$$\gamma(t) = \int_0^{\infty} \gamma'(t) dt. \quad (1)$$

$$\gamma'(t) = \gamma(t)/dt, \quad (2)$$

The maximization algorithm 6 is applicable also for the equations (6.4.37), where  $E(t) = E_o(t)\gamma'(t)$ .

**Example 9a.** Let us consider an equation

$$Sq + Rq' - E\gamma'(t) = 0, \quad (a)$$

where  $E$  is a constant. The solution of this equation is

$$q' = \frac{E}{R} \left( \gamma' + \frac{S}{R} \left( -\gamma + 1 - \exp\left(-\frac{S}{R}t\right) \right) \right).$$

Note that

$$q = \int_0^t q' \cdot d\tau = \frac{E}{R} \left( \gamma - \frac{S}{R} \left( \int_0^t \exp\left(-\frac{S}{R}\tau\right) \cdot d\tau \right) \right) = \frac{E}{R} \left( \gamma - \left|_0^t \exp\left(-\frac{S}{R}\tau\right) \right. \right),$$

i.e.

$$q = \frac{E}{R} \left( \gamma - 1 + \exp\left(-\frac{S}{R}t\right) \right)$$

Solution of the equation (a) for  $t > 0$  has the form

$$q' = -\frac{ES}{R^2} \exp\left(-\frac{S}{R}t\right). \quad (b)$$

$$q = \frac{E}{R} \exp\left(-\frac{S}{R}t\right). \quad (c)$$

For  $t \rightarrow 0$  we have

$$q' \rightarrow -\frac{ES}{R^2}, \quad q \rightarrow \frac{E}{R}, \quad (\text{A})$$

But at the moment  $t = 0$  the derivative exhibits a jump

$$q' = \frac{E}{R} \left( \gamma' - \frac{ES}{R^2} \right), \quad (\text{e})$$

and the function exhibits a jump

$$q = \frac{E}{R} \gamma. \quad (\text{d})$$

By direct substitution into the initial equation we can ascertain that the solution is correct – see Fig. 1 (see also function FigGamma). For physical interpretation of this equation one should have in mind that the function  $\gamma'(t)$  is non-dimensional, and the function  $\gamma(t)$  has the dimension of independent variable  $t$ . To solve this equation we shall use the optimization algorithm 7.

0. Begin with  $q(t) = 0$ .

1. Compute  $u(t) = u_1(t) = \frac{E\gamma(t)}{R}$  and compute

$$q(t) = q_1(t) = \int_0^t u_1(\tau) \cdot d\tau = \frac{E}{R} \gamma(t).$$

2. Then compute consequently

$$u_2 = -\frac{S}{R} q_1 = -\frac{SE}{R^2} \gamma(t), \quad q_2(t) = \int_0^t u_2(\tau) \cdot d\tau = -\frac{SE}{R^2} t,$$

$$u_3 = -\frac{S}{R} q_2 = \frac{S^2 E}{R^3} t, \quad q_3(t) = \int_0^t u_3(\tau) \cdot d\tau = \frac{S^2 E}{2R^3} t^2,$$

$$u_4 = -\frac{S}{R} q_3 = -\frac{S^3 E}{2R^4} t^2, \quad q_4(t) = \int_0^t u_4(\tau) \cdot d\tau = -\frac{S^3 E}{6R^4} t^3$$

and so on. Thus,

$$u(t) = \frac{E}{R} \left( \gamma'(t) - \frac{S}{R} \gamma(t) + \frac{S^2}{R^2} t - \frac{S^3}{2R^3} t^2 + \dots \right)$$

$$q(t) = \frac{E}{R} \left( \gamma(t) - \frac{S}{R} t + \frac{S^2}{2R^2} t^2 - \frac{S^3}{6R^3} t^3 + \dots \right)$$

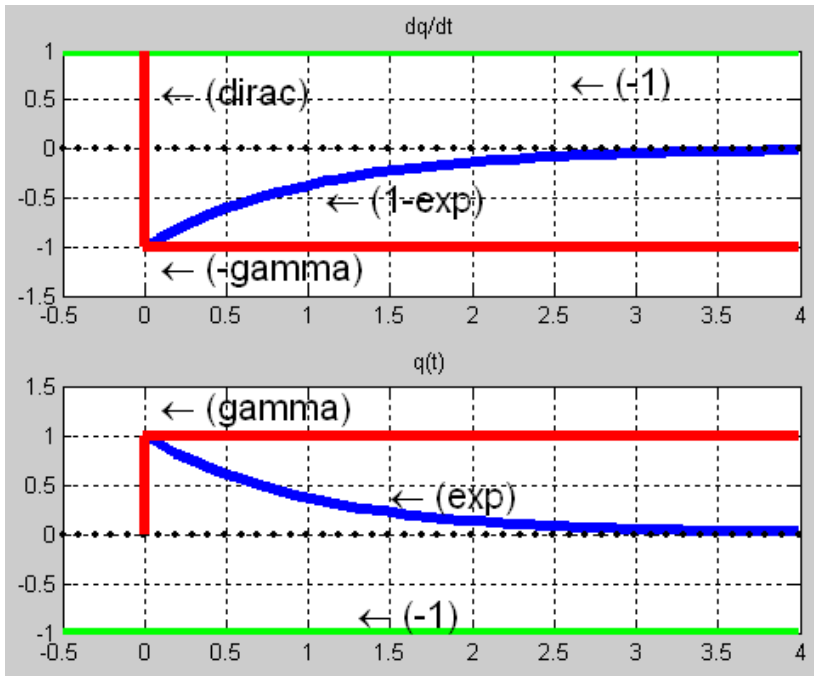

Fig. 1.

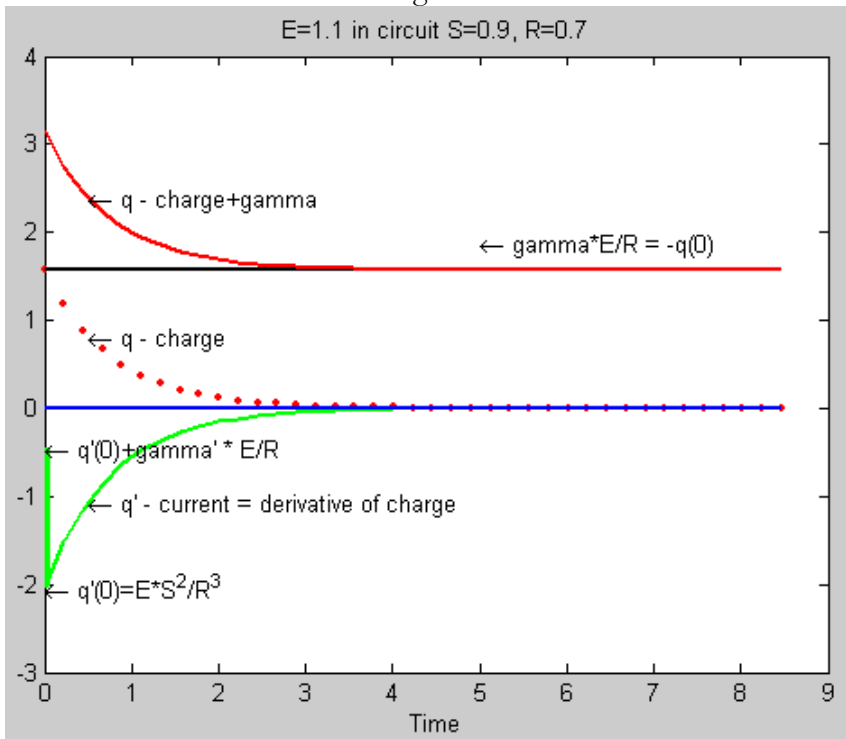

Fig. 2.

One may see that on each iteration one item is added to the series of functions  $q(t)$ . Also we can see that with the increase of the iterations number  $q(t)$ ,  $q'(t)$  are approaching the results indicated at the beginning of the example.

So we see that the maximization algorithm 6 computes the sought function. The fig. 2 shows graphs of the functions  $q(t)$ ,  $q'(t)$  for some fixed parameter values (see also function testDirak\_1).

In reality there are no such cases when the voltage or the current of sources may be described by Dirac function time-varying. But we can imagine some electric or other systems where the impact may be described by Dirac function of space coordinates. Let us consider an example.

**Example 9b1.** considers a long line described in example 5.6.3. When the number of elements is large, this line may be considered as a continuous line with parameters depending on the length  $z$ , and the equation  $q'_2 = N_2 q'_1$  may be substituted by the equation  $q'_2 = \frac{dq'_1}{dz}$  (this is shown in Chapter 8). Thus the line as a whole is described by the equation

$$x(z) + T(z) \cdot \frac{dx(z)}{dz} - P(z).$$

If  $P(z) = \begin{cases} E, & \text{if } z = 0, \\ 0, & \text{if } z > 0, \end{cases}$  (as it is done in example 5.6.3), then,

naturally, we must assume that  $P(z) = E\gamma'(z)$ . Then the equation of this line will take a form

$$Sx(z) + R \cdot \frac{dx(z)}{dz} - E\gamma'(z) = 0, \text{ where } S = 1, R = T(z).$$

Exactly this equation has been considered above. So the discussed continuous line may be computed with the aid of maximization algorithm 6 with Dirac functions as excitations – compare the graphs in examples 5.6.3 and 9a.

The computing algorithms for Dirac functions as excitations may be extended also for vector variables in the equation (6.4.37), where  $E(t) = E_0 \gamma'(t)$  and  $S, R$  are quadratic matrices.

**Example 9c2.** Consider a system of two differential equations  $q_1(t), q_2(t)$  with regard to independent variable  $t$ :

$$\beta q_1 - q_2' = 0,$$

$$2\beta q_2 + q_1' = \rho \gamma'(t).$$

Consider the vector  $q = \begin{vmatrix} q_1 \\ q_2 \end{vmatrix}$ . Then this system may be presented in the form

$$Sq + Rq' = E\gamma'(z),$$

where  $E = \begin{vmatrix} 0 \\ \rho \end{vmatrix}$ ,  $S = \beta \begin{vmatrix} 1 & 0 \\ 0 & 2 \end{vmatrix}$ ,  $R = \begin{vmatrix} 0 & -1 \\ 1 & 0 \end{vmatrix}$ . Now we have:

$$u = \begin{vmatrix} q_1' \\ q_2' \end{vmatrix} = \begin{vmatrix} \rho \gamma' - 2\beta q_2 \\ \beta q_1 \end{vmatrix}.$$

*On the first iteration:*

1. At the beginning we assume that  $q(t) = 0$ .

2. Compute  $u = \begin{vmatrix} \rho \gamma' \\ 0 \end{vmatrix}$

3. Compute  $q(t) = \int_0^t u(\tau) \cdot d\tau = \begin{vmatrix} \rho \gamma \\ 0 \end{vmatrix}$ .

*On the second iteration:*

2. Compute  $u = \begin{vmatrix} \rho \gamma' \\ \beta \rho \gamma \end{vmatrix}$

3. Compute  $q(t) = \int_0^t u(\tau) \cdot d\tau = \begin{vmatrix} \rho \gamma \\ \beta \rho t \end{vmatrix}$

*On the third iteration:*

2. Compute  $u = \left| \frac{\rho\gamma' - 2\beta^2\rho t}{\beta\rho\gamma} \right|$

3. Compute  $q(t) = \int_0^t u(\tau) \cdot d\tau = \left| \frac{\rho\gamma - \beta^2\rho t^2}{\beta\rho t} \right|$

On the fourth iteration:

2. Compute  $u = \left| \frac{\rho\gamma' - 2\beta^2\rho t}{\beta\rho\gamma - \beta^3\rho t^2} \right|$

3. Compute  $q(t) = \int_0^t u(\tau) \cdot d\tau = \left| \frac{\rho\gamma - \beta^2\rho t^2}{\beta\rho t - \beta^3\rho t^3/3} \right|$

On the fifth iteration:

2. Compute  $u = \left| \frac{\rho\gamma' - 2\beta^2\rho t + 2\beta^4\rho t^3/3}{\beta\rho\gamma - \beta^3\rho t^2} \right|$

3. Compute

$$q(t) = \int_0^t u(\tau) \cdot d\tau = \left| \frac{\rho\gamma - \beta^2\rho t^2 + 2\beta^4\rho t^4/(3 \cdot 4)}{\beta\rho t - \beta^3\rho t^3/3} \right|$$

On the sixth iteration:

2. Compute  $u = \left| \frac{\rho\gamma' - 2\beta^2\rho t + 2\beta^4\rho t^3/3}{\beta\rho\gamma - \beta^3\rho t^2 + 2\beta^5\rho t^4/(3 \cdot 4)} \right|$

3. Compute

$$q(t) = \int_0^t u(\tau) \cdot d\tau = \left| \frac{\rho\gamma - \beta^2\rho t^2 + 2\beta^4\rho t^4/(3 \cdot 4)}{\beta\rho t - \beta^3\rho t^3/3 + 2\beta^5\rho t^5/(3 \cdot 4 \cdot 5)} \right|$$

So after the iterations we shall have

$$u = \rho \left| \frac{\gamma' - 2\beta \left[ \beta t - (\beta t)^3/3 + \dots \right]}{\beta\gamma - \beta \left[ (\beta t)^2 - 2(\beta t)^4/(3 \cdot 4) + \dots \right]} \right|$$

$$q(t) = \rho \left[ \begin{array}{l} \gamma - \left[ \beta t \right]^2 - 2(\beta t)^4 / (3 \cdot 4) + \dots \\ \left[ \beta t - (\beta t)^3 / 3 + 2(\beta t)^5 / (3 \cdot 4 \cdot 5) - \dots \right] \end{array} \right]$$

Let us denote  $\chi = \beta\sqrt{2}$ . Then we shall get:

$$u = \rho \left[ \begin{array}{l} \gamma' - \sqrt{2}\beta \left[ \chi t - (\chi t)^3 / (2 \cdot 3) + \dots \right] \\ \beta\gamma - \beta \left[ (\chi t)^2 / 2 - (\chi t)^4 / (2 \cdot 3 \cdot 4) + \dots \right] \end{array} \right]$$

$$q(t) = \rho \left[ \begin{array}{l} \gamma - \left[ (\chi t)^2 / 2 - (\chi t)^4 / (2 \cdot 3 \cdot 4) + \dots \right] \\ \frac{1}{\sqrt{2}} \left[ \chi t - (\chi t)^3 / (2 \cdot 3) + (\chi t)^5 / (2 \cdot 3 \cdot 4 \cdot 5) - \dots \right] \end{array} \right]$$

It is easy to see that the series placed within square brackets are the series of functions  $\sin(\chi t)$  and  $[1 - \cos(\chi t)]$ . Hence,

$$u = \rho \left[ \begin{array}{l} \gamma' - \sqrt{2}\beta \sin(\chi t) \\ \beta(\gamma - 1 + \cos(\chi t)) \end{array} \right], \quad q(t) = \rho \left[ \begin{array}{l} \gamma - 1 + \cos(\chi t) \\ \frac{1}{\sqrt{2}} \sin(\chi t) \end{array} \right],$$

which presents the solution of the problem. The Figure shows the graphs of functions  $q(t)$ ,  $q'(t)$  with certain values of the parameters (see also function testFig6\_9b2).

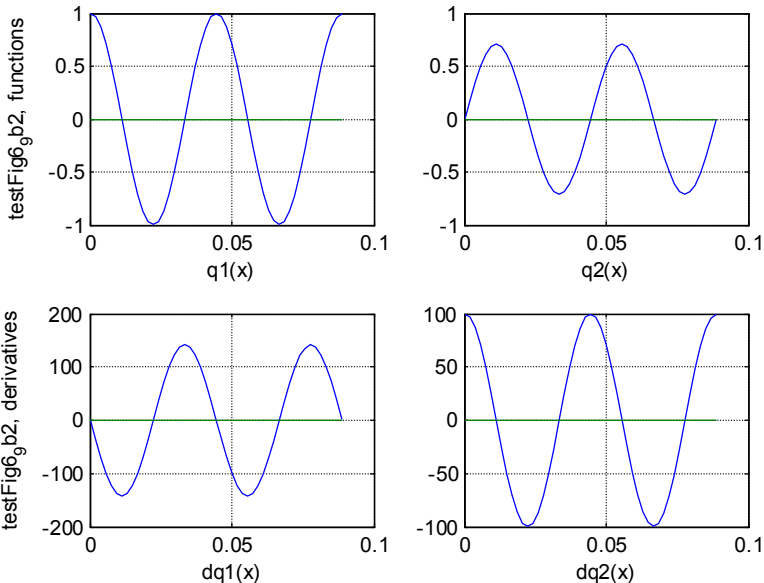

**Example 9c.** Let us consider the program realizing the maximization algorithm 6 for finding the solution of equation system (37) with  $E(t) = E_o\gamma'(t)$ . The main function **DEdirak** is similar to the one described in Example 6 function **DEjump**, and the notations and subsidiary functions are the same. The following Figure illustrates (see also function `testDirak_3`) the results of computations for 3 equations system, using the discussed program. The Figure shows graphs of functions  $x(t)$ ,  $x'(t)$ .

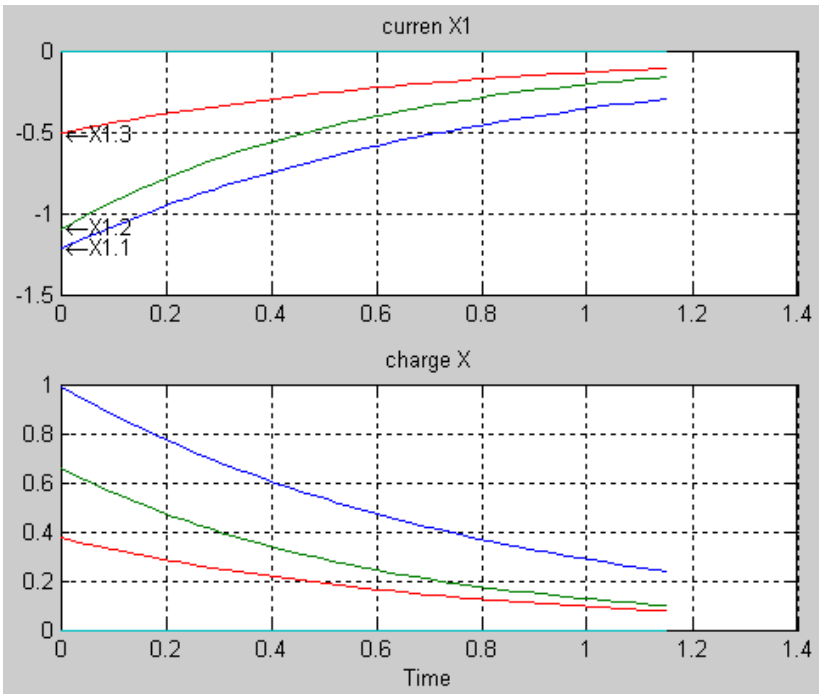

**Example 9d.** Let us consider a system of two differential equations of variable  $z$ :

$$S_1 h(z) + R_1 \frac{de(z)}{dz} = E_1 \gamma'(z),$$

$$S_2 e(z) + R_2 \frac{dh(z)}{dz} = E_2 \gamma'(z).$$

Consider vector  $x(z) = \begin{pmatrix} h(z) \\ e(z) \end{pmatrix}$ . Then the system may be presented in the form



$$Sx(z) + R \frac{dx(z)}{dz} = E\gamma'(z),$$

where  $E = \begin{bmatrix} E_1 \\ E_2 \end{bmatrix}$ ,  $S = \begin{bmatrix} S_1 & 0 \\ 0 & S_2 \end{bmatrix}$ ,  $R = \begin{bmatrix} 0 & R_1 \\ R_2 & 0 \end{bmatrix}$ . The following Figure

illustrates (see also function `testDirak_2`) the results of computations this equation at

$$E = \begin{bmatrix} E_1 = 0 \\ E_2 = -10 \end{bmatrix}, S = \begin{bmatrix} S_1 = 3.1 & 0 \\ 0 & S_2 = 0.1 \end{bmatrix}, R = \begin{bmatrix} 0 & R_1 = -16 \\ R_2 = 3 & 0 \end{bmatrix}.$$

The Figure shows graphs of functions  $x(t)$ ,  $x'(t)$ .

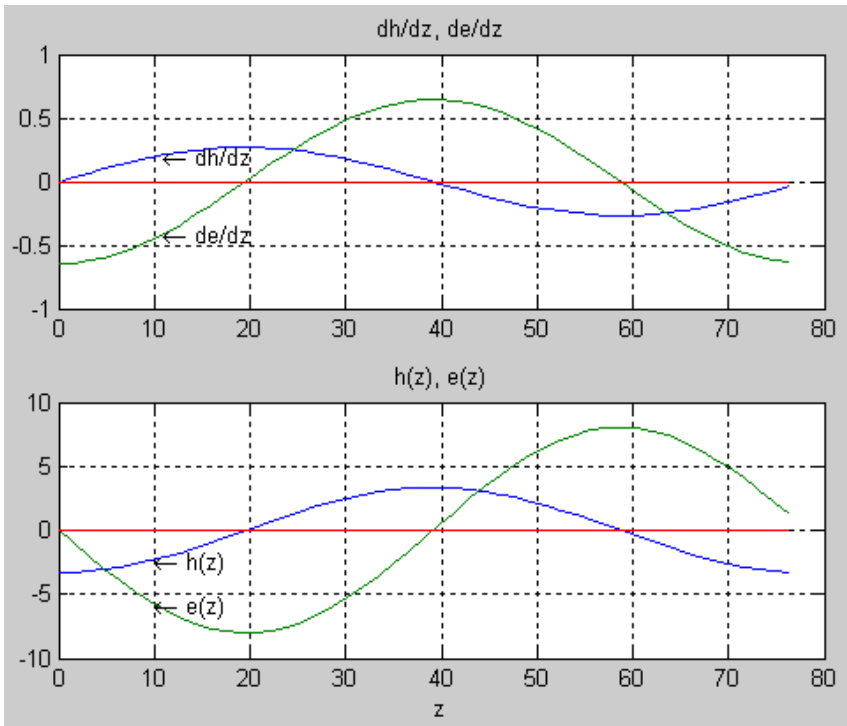

As stated above, the maximization algorithm 6 is applicable also, when the value  $R$  is a function  $R(t)$  of an independent variable  $t$ . Chapter 9 will deal with the examples of solving the Maxwell equations as equations with excitations in the form of Dirac functions of spatial coordinates.

## 6a. Second Order Differential Equations Systems with Excitations in the Form of Dirac Functions

The maximization algorithm 3 is applicable also for the equations (6.4.24), where  $E(t) = E_o(t)\gamma'(t)$ .

### Maximization algorithm 8.

1. Assume that  $q(t) \equiv 0$  and  $u(t) \equiv 0$ .
2. Compute  $\psi' = -Sq - \frac{1}{2}Ru + E$ .
3. Compute  $\psi(t) = \int_0^t \psi'(\tau) \cdot d\tau$  with known  $\psi'(0)$ .
4. Compute  $u = \frac{1}{L} \left( \psi - \frac{1}{2}Rq \right)$ .
5. Check the variation of function  $u(t)$  compared with its previous value and, if it is sufficiently small, stop the computation.
6. Compute  $q(t) = \int_0^t u(\tau) \cdot d\tau$  with known  $u(0)$ .
7. Go to p. 2.

**Example 9e.** Let us the equation

$$Sq + Rq' + Lq'' - E\gamma'(t) = 0, \quad (\text{a})$$

where  $E$  – a constant. Let us use the maximization algorithm 8. On the first iteration

1. Assume that  $q(t) \equiv 0$  and  $u(t) \equiv 0$ .
2. Compute  $\psi'(t) = -Sq - \frac{1}{2}Ru + E\gamma'(t) = E\gamma'(t)$ .
3. Compute  $\psi(t) = \int_0^t \psi'(\tau) \cdot d\tau = E\gamma(t)$
4. Compute  $u = \frac{1}{L} \left( \psi - \frac{1}{2}Rq \right) = \frac{E}{L} \gamma(t)$ .
5. Compute  $q(t) = \int_0^t u(\tau) \cdot d\tau = \frac{E}{L} t$ .

On the second iteration

2. Compute  $\psi'(t) = -Sq - \frac{1}{2}Ru + E\gamma'(t) = -\frac{SE}{L}t - \frac{ER}{2L}\gamma(t) + E\gamma'(t)$ .

$$3. \text{ Compute } \psi(t) = -\frac{SE}{2L}t^2 - \frac{RE}{L}t + E\gamma(t)$$

$$4. \text{ Compute } u = \frac{1}{L}\left(\psi - \frac{1}{2}Rq\right) = -\frac{SE}{2L^2}t^2 - \frac{2RE}{L^2}t + \frac{E}{L}\gamma(t).$$

$$5. \text{ Compute } q(t) = \int_0^t u(\tau) \cdot d\tau = -\frac{SE}{6L^2}t^3 - \frac{RE}{L^2}t^2 + \frac{E}{L}t.$$

Let us assume that on a particular iteration we got:

$$q(t) = E \sum_{k=1}^n a_k t^k, \quad u(t) = E \left( \frac{\gamma(t)}{L} + \sum_{k=1}^{n-1} b_k t^k \right).$$

Then

$$\begin{aligned} \psi'(t) &= -Sq - \frac{1}{2}Ru + E\gamma'(t) = \\ &= -SE \sum_{k=1}^n a_k t^k - \frac{ER}{2} \left( \frac{\gamma(t)}{L} + \sum_{k=1}^{n-1} b_k t^k \right) + E\gamma'(t) = \\ &= -E \left( \sum_{k=1}^n c_k t^k + \frac{R\gamma(t)}{2L} + \gamma'(t) \right), \end{aligned}$$

$$c_k = \left( Sa_k + \frac{1}{2}Rb_k \right), \quad \text{if } k < n,$$

$$c_n = Sa_n.$$

$$2. \text{ Compute } \psi(t) = -E \left( \sum_{k=1}^n \frac{c_k}{k+1} t^{k+1} + \frac{R}{2L}t + \gamma(t) \right).$$

3. Compute

$$\begin{aligned} u(t) &= \frac{1}{L} \left( \psi - \frac{1}{2}Rq \right) = \\ &= -\frac{E}{L} \left( \sum_{k=1}^n \frac{c_k}{k+1} t^{k+1} + \frac{R}{2L}t + \frac{\gamma(t)}{L} \right) - \frac{ER}{2L} \sum_{k=1}^n a_k t^k = \\ &= -E \left( \sum_{k=1}^{n+1} b_k t^k + \frac{\gamma(t)}{L^2} \right), \end{aligned}$$

$$b_1 = \frac{R}{2L^2}(a_1 + 1), \quad b_{k>1} = \left( \frac{c_{k-1}}{L^2 k} + \frac{Ra_k}{2L^2} \right).$$

$$4. \text{ Compute } q(t) = \int_0^t u(\tau) \cdot d\tau = -E \left( \sum_{k=2}^{n+2} \frac{b_{k-1}}{k} t^k + \frac{t}{L^2} \right).$$

We see that on each iteration the series of the function  $q(t)$  is supplemented by two items.

It may be noted that the presented algorithm is applicable also for vector variables, where  $L$ ,  $S$ ,  $R$  are quadratic matrices.

## 7. Maximization Algorithm for the Electrical Circuits Computation

The described algorithm is easily programmable and may be used for finding the solution of system (6.324) with step excitations. But very often it is not applicable for a real electric circuit computation. Indeed, we had considered an algorithm for computing RCL-circuit, described by equation system (6.324). Such system describes an unconditional circuit. However, there exist the following limitations for its *direct* use:

- 1) The absence of inductance even in one branch of electric circuit leads to violation of condition (6.323) and, consequently, to division by 0. In this case the electric circuit should be supplemented by relatively small inductances in those branches where they were absent.
- 2) An unconditional electric circuit is approaching the state of a real electric circuit when methodic resistance approaches infinity. But this results in resistances matrix approaching a positive **semidefinite** (and not positive definite) matrix. And the observation interval approaches zero.

Let us now consider some examples of electric circuits computations which meet these requirements.

**Example 10.** Consider electric circuit depicted in the Fig. 2 . The parameters of this circuit are enumerated in the Table 1.

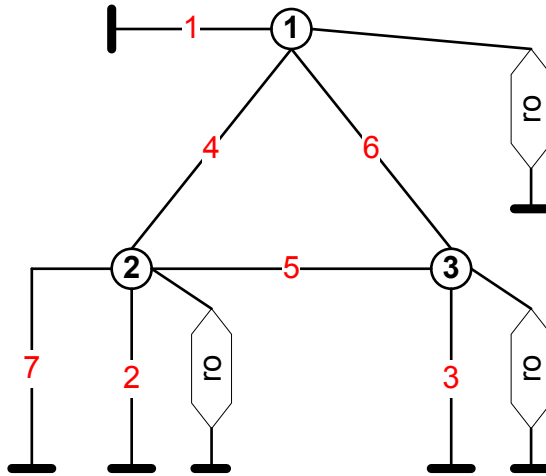

Fig. 2.

The voltage in branch 7 jumps to the named value at the initial moment. Apparently, there are inductances present in every branch. Also, resistances  $ro=1.5$  are attached to all the nodes. These resistances are physically present in the circuit, but at the same time they may be interpreted as methodic resistances. The considered circuit is described by differential equations system (24) and may be computed with the aid of maximization algorithm 3.

Table 1 (see also function Branches23) .

| Branch | First node | End node | Voltage | R (ohm) | L (gn) | S (1/ph) |
|--------|------------|----------|---------|---------|--------|----------|
| 1      | 0          | 1        | 0       | 0.2     | 3      | 10000    |
| 2      | 0          | 2        | 0       | 0.3     | 4      | 10000    |
| 3      | 0          | 3        | 0       | 0.4     | 5      | 10000    |
| 4      | 1          | 2        | 0       | 5       | 6      | 100      |
| 5      | 2          | 3        | 0       | 6       | 7      | 200      |
| 6      | 3          | 1        | 0       | 1       | 8      | 300      |
| 7      | 2          | 0        | -192    | 0.01    | 0.01   | 0        |

Let us now discuss the program **LinCir** for such circuits computation. This program contains the following M-functions (here we are using the notations assumed in the description of function **SinCir** in section 5.6 and function **DEjump** in section 6.3.

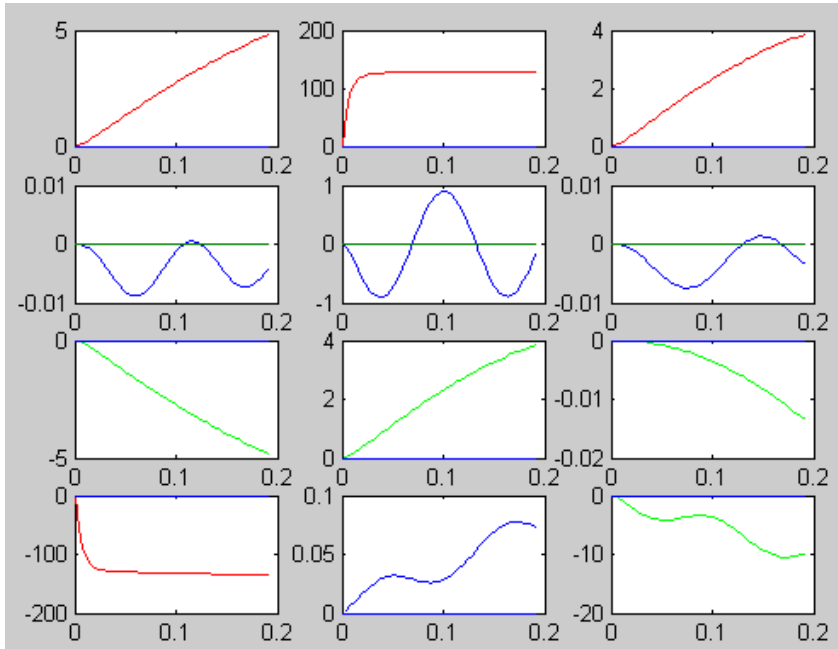

Fig. 3.

Fig. 3 (see also function `testLin`) shows the graphs of current variation in all braches of this circuit: in the first line of windows there are currents  $i_i$  in the resistances  $r_o$  of nodes 1, 2, 3; in the second line of windows – currents  $qqt$  in branches 1, 2, 3; in the third line of windows – currents  $qqt$  in branches 4, 5, 6; in the fourth line and in the left window – current  $qqt$  in branch 7; in the fourth line and the right window – the sum of currents in node 2, which is the residual of the First Kirchhoff Law; in the first line and in the middle window – relative (to the current of branch 7) residual of the First Kirchhoff Law.

**Example 11.** Let us now take up the electric circuit shown in the Fig.4.

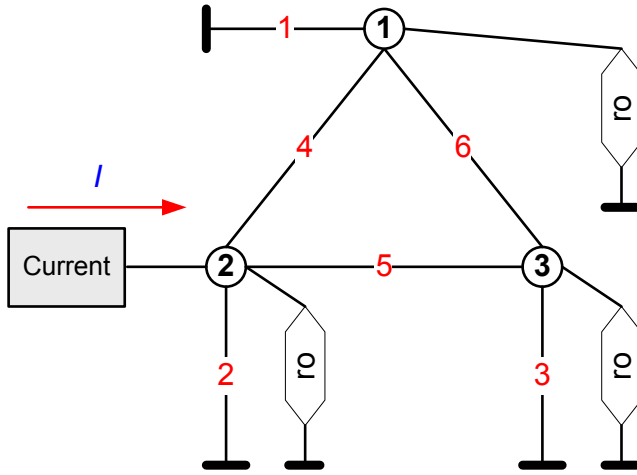

Fig. 4.

Parameters of this circuit are enumerated in the Table 2. Furthermore, there is a source of direct current connected to the node 2 and its current jumps to  $I=-3$  at the initial moment. Apparently, there are inductances in all branches. In addition (as also in Example 10), resistances  $ro=1.5$  are connected to all the nodes. These resistances are physically present in the circuit, but at the same time they may be considered as methodic resistances. After transformation into an unconditional circuit the current  $I=-3$  is substituted by a voltage vector  $E'=[0, 4.5, 0, 4.5, -4.5, 0]$ . This circuit is described by a differential equations system (24) and may be computed with the aid of maximization algorithm 3. The functions from Example 10 may be used for the computation.

Table 2 (see also function Branches21) .

| Branch | First node | End node | Voltage | R (ohm) | L (gn) | S (1/ph) |
|--------|------------|----------|---------|---------|--------|----------|
| 1      | 0          | 1        | 0       | 0.2     | 3      | 1000000  |
| 2      | 0          | 2        | 0       | 0.3     | 4      | 0        |
| 3      | 0          | 3        | 0       | 0.4     | 5      | 0        |
| 4      | 1          | 2        | 0       | 5       | 6      | 100      |
| 5      | 2          | 3        | 0       | 6       | 7      | 0        |
| 6      | 3          | 1        | 0       | 1       | 8      | 300      |

Fig. 5 (see also function testLin21) shows the graphs of current variation in all the branches of this circuit: in the first line of windows there are currents  $i_i$  in the resistances  $ro$  of nodes 1, 2, 3;

in the second line of windows – currents  $qqt$  in the branches 1, 2, 3; in the third line of windows – currents  $qqt$  in the branches 4, 5, 6; in the fourth line of windows - relative (to the current  $I=-3$ ) residual of the First Kirchhoff Law. Note, that these functions compute the variable components of the currents – the power series coefficients for the series terms with power higher than zero. The constant component of the currents  $\dot{i}$  is the constant power series term equal to the current  $HH'=[0, -3, 0]$ .

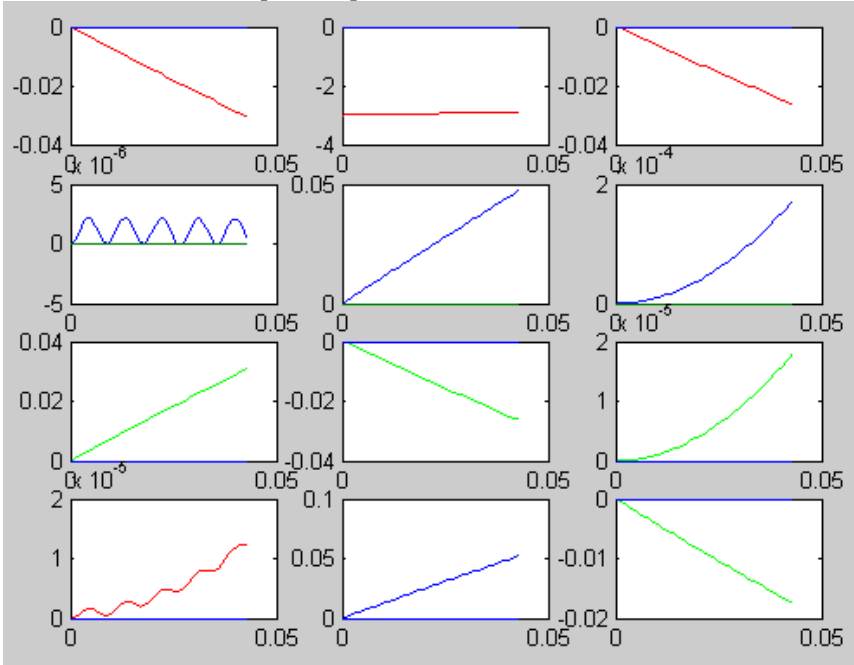

Fig. 5.

## 8. Maximization Algorithms for Computing Electric Circuits with Switchings

As it is known [14], with voltage jump a current appears, which may be considered as a sum of two currents – established one and free one. The same may be said about the charges. Let us show that the maximization algorithm does not change the established charges. Let us use the maximization algorithm 3:



1. Assume that  $q(t)$  and  $u(t) = q'(t)$  satisfy the of unconditional electric circuit

$$Sq + Rq' + Lq'' - E = 0.$$

2. Compute  $\psi' = -Sq - \frac{1}{2}Ru + E$ .
3. Compute  $\psi(t) = \int_0^t \psi'(\tau) \cdot d\tau$  with known  $\psi'(0)$ .
4. Compute

$$\begin{aligned} u &= \frac{1}{L} \left( \psi - \frac{1}{2}Rq \right) = \frac{1}{L} \left( -S\hat{q} - \frac{1}{2}R\hat{u} + \hat{E} - \frac{1}{2}Rq \right) = \\ &= \frac{1}{L} \left( -S\hat{q} - \frac{1}{2}Rq + \hat{E} - \frac{1}{2}Rq \right) = \frac{1}{L} \left( -S\hat{q} - Rq + \hat{E} \right) = \frac{1}{L} (Lq') = q' \end{aligned}$$

which proves the statement.

On the other hand, the maximization algorithm in essence cannot be used for computing the established values, for the interval of these values is not limited from the left. Thus, for computation of a circuit with a voltage that is a function of time  $E=f(t)$ , and at the zero moment jumps to the value  $f(0)$ , it is necessary to:

1. Compute the established charge by any method (for instance, by one of the methods presented in the previous chapters),
2. Compute the free current as a reaction to the jump, by the maximization method,
3. Perform a superposition of these currents.

We shall now examine this method in more details on the examples of computing the after-failure mode after short circuit and branch break.

### Short Circuit

Consider an electrical circuit with two clamps A and B. In a normal mode there is a potential difference  $\mathcal{V}$  between the clamps A and B. On short circuit of these clamps current  $i$  will pass through the connection AB. We shall now consider the same electric circuit, excluding from it all current and voltage sources and including between the clamps A and B a voltage source with null internal connection and voltage  $(-\mathcal{V})$ . Then the same current  $i$  will pass through the connection AB and through this voltage source [14]. It follows herefrom, that short circuit current and all other parameters of after-failure mode may be computed using the following algorithm

### Computing Algorithm for Short Circuit

1. Computing the normal mode of electric circuit 1 and determining the potential difference  $\mathcal{V}$  between clamps A and B.
2. Transforming the initial electric circuit 1 into electrical circuit 2, differing from the initial circuit by the absence of all current and voltage sources, and the presence of voltage source  $(-\mathcal{V})$  between the clamps A and B.
3. Computing the electrical circuit 2 at the time of voltage jump between clamps A and B from  $(0)$  to  $(-\mathcal{V})$ . The vector of currents  $I\mathcal{3}$  is determined.
4. Transforming the initial electric circuit 1 into electrical circuit 3, differing from the initial circuit by the appearance of short circuit AB. The vector of currents  $I\mathcal{4}$  of the after-failure mode is determined.
5. Computing the currents of after-failure mode as a sum of currents  $I\mathcal{3}$  and  $I\mathcal{4}$ .

The computation of currents  $I\mathcal{3}$  may be performed with the aid of maximization algorithm 3, as described above. The computation of currents  $I\mathcal{4}$  may be performed according to section 5.6.

### Branch Break

Consider an electric circuit, where certain clamps A and B are marked out. In a normal mode the current  $i$  passes between A and B. With breaking the circuit between A and B a potential difference  $\mathcal{V}$  will appear between A and B. Consider now this same electric circuit, except for eliminating all the current and voltage sources, and including a current source  $(-i)$  between A and B. Then there appears the same potential difference  $\mathcal{V}$  between A and B [14]. It follows herefrom, that the potential difference at the ends of broken branch and all the other parameters may be computed with the aid of the following algorithm.

### Computing Algorithm for Branch Break

1. Computing the normal mode of electric circuit 1 and determining the current  $i$  between the clamps A and B.
2. Transforming the initial electric circuit 1 into electrical circuit 2, differing from the initial circuit by the absence of all current and voltage sources, and the presence of current source  $(-i)$  between the clamps A and B.

3. Computing the electrical circuit 2 at the time of current jump between clamps A and B from (0) to  $(-i)$ . The vector of currents  $I3$  is determined.
4. Transforming the initial electric circuit 1 into electrical circuit 3, differing from the initial circuit by the appearance of current source  $(-i)$  instead of the former branch AB. The vector of currents  $I4$  of the after-failure mode is determined.
5. Computing the currents of after-failure mode as a sum of currents  $I3$  and  $I4$ .

The computation of currents  $I3$  may be performed with the aid of maximization algorithm 3, as described above. The computation of currents  $I4$  may be performed according to section 5.6.

# Chapter 7. Electromechanical Systems

---

## 1. General Case

The preceding results may (as was mentioned before) be interpreted as a method for solution of the system of second-order differential equations with respect to variable  $q(t)$  :

$$\bar{S}q + \bar{M}q'' + \bar{R}q' - \bar{E} = 0. \quad (1)$$

The solution of this system is a consequence of the simultaneous optimization of two functionals (4.13) and (4.14), where  $q_o = x_o + y_o$ ,  $q'_o = v_o + w_o$ . With the exception of DT and IT transformers the same system may be presented also in the following form:

$$Sq + Mq'' + Rq' - E + \rho N^T (Nq' + H) = 0. \quad (2)$$

Let us supplement an unconditioned electrical circuit corresponding to the equation (2), with branches of the third type, included between the node and the “ground”. We shall call such circuits “differentiating circuits”, as they are described by a pair of differential equations of the following form:

$$a_1 J'' + b_1 J' + c_1 J + d_1 X'' + e_1 X' + f_1 X + h_1 = \varphi, \quad (3)$$

$$a_2 J'' + b_2 J' + c_2 J + d_2 X'' + e_2 X' + f_2 X + h_2 = 0, \quad (4)$$

where

$\varphi$  - the node potentials,

$J$  - the differentiating nodes currents,

$X$  - the “outside” variables,

$a, b, c, d, e, f, h$  - known values.

In an unconditioned electrical circuit the node potentials are equal to  $\varphi = \rho \cdot i$ , and the currents through node resistances in this case are equal to

$$i = Nq' + H - J. \quad (5)$$

Then the electrical circuit's system of equations takes the form:

$$\left\{ \begin{array}{l} Mq'' + Rq' + Sq - E + \rho N^T (Nq' + H - J) = 0, \\ a_1 J'' + b_1 J' + c_1 J + d_1 X'' + e_1 X' + \\ \quad + f_1 X + h_1 - \rho (Nq' + H - J) = 0, \\ a_2 J'' + b_2 J' + c_2 J + d_2 X'' + e_2 X' + f_2 X + h_2 = 0. \end{array} \right. \quad (6)$$

This system may be rewritten in the following form:

$$\overline{M}Q'' + \overline{R}Q' + \overline{S}Q - \overline{E} = 0, \quad (7)$$

where

$$Q = \begin{vmatrix} q \\ J \\ X \end{vmatrix}, \quad \overline{E} = \begin{vmatrix} E - \rho N^T H \\ h_1 - \rho H \\ h_2 \end{vmatrix}, \quad \overline{M} = \begin{vmatrix} M & 0 & 0 \\ 0 & a_1 & d_1 \\ 0 & a_2 & d_2 \end{vmatrix},$$

$$\overline{R} = \begin{vmatrix} (R + \rho N^T N) & 0 & 0 \\ (-\rho N) & b_1 & e_1 \\ 0 & b_2 & e_2 \end{vmatrix}, \quad \overline{S} = \begin{vmatrix} S & (-\rho N^T) & 0 \\ 0 & (c_1 + \rho) & f_1 \\ 0 & c_2 & f_2 \end{vmatrix}.$$

Comparing (1), (7) and having in view the notation for  $Q$ , we get

$$G = \begin{vmatrix} q' \\ J' \\ X' \end{vmatrix}.$$

The solution method for the equation (7) is fully similar to the solution method for the equation (1) and is as follows:

1. given is the initial value of the variable  $Q(t)$ ,
2. compute the gradient  $p(t)$ , which is equal to the left part of these equations,
3. compute the values of  $A'_1$ ,  $A'_2$ ,  $B_1$ ,  $B_2$  by formulas (3.11),
4. compute the variable's increment  $Q(t)$  by formula (3.10) and the new value of this variable,
5. repeat the computations of pp. 2, 3, 4 till the prescribed accuracy is reached.

Equation (3) may describe a certain electromechanical element, where the "outside" variables are coordinates, velocities, accelerations, forces, moments, temperature, pressure and other variables describing non-

electrical processes – mechanical, thermal, hydraulic processes. The system of equation (6) describes a system of electromechanical elements connected by an electrical circuit. The following variants of such systems may be noted:

1. Electrical circuit. Then:

$$a = 0, b = 0, c = 0, d = 0, e = 0, f = 0, h = 0, Q = q.$$

2. Non-electrical (mechanical, thermal, hydraulic); electrical circuit is absent,

$$a = 0, b = 0, c = 0, Q = X,$$

and only a part of the equation (4) is left in the form:

$$d_2 X'' + e_2 X' + f_2 X + h_2 = 0.$$

3. Electrical circuit in which the differentiating branches contain only electrical elements; then

$$d = 0, e = 0, f = 0, h = 0, Q = \begin{vmatrix} q \\ J \end{vmatrix},$$

and the values  $a$ ,  $b$ ,  $c$  have the following meaning correspondingly: inductance or inter-inductance of several differentiating branches, resistance, capacitance. Notice that a circuit of such configuration may be constructed without bringing in the concept of differentiating branches.

4. Electromechanical system – the general case. Some of the differentiating branches may:

- be absent,
- contain only electrical elements,
- contain only mechanical, thermal, hydraulic elements,
- contain electromechanical elements in which the electromagnetic energy is converted into mechanical or thermal energy, or a reverse conversion takes place; these are precisely the elements that form the electromechanical system as such.

The most commonly encountered elements and their equations are collected in the table 1.

Table 1.

|   | Type of element                              | $u = R \cdot i$   | $u = L \cdot \frac{di}{dt}$  | $i = C \cdot \frac{du}{dt}$  |
|---|--|---|--|--|
| 1 | Electrical                                   | voltage =<br>resistance *<br>current  | voltage =<br>inductance *<br>current's<br>derivative                                 | current =<br>capacitance *<br>voltage<br>derivative                                    |
| 2 | Mechanical with<br>translational<br>movement | displacement =<br>damping<br>resistance *<br>force  | displacement =<br>spring force*<br>force's<br>derivative                             | force = mass *<br>displacement's<br>derivative   |
| 3 | Mechanical with<br>rotational<br>movement    | angular<br>displacement =<br>rotating<br>dampener's<br>resistance *<br>moment of<br>force | angular<br>displacement =<br>rotating<br>dampener's<br>force *<br>moment of<br>force | moment of<br>force =<br>moment of<br>inertia * angular<br>displacement's<br>derivative |
| 4 | Hydraulic                                    | pressure =<br>hydraulic<br>resistance *<br>flow   |  | flow =<br>hydraulic<br>capacity*<br>pressure's<br>derivative                           |
| 5 | Thermal                                      | temperatures<br>difference =<br>thermal<br>resistance *<br>heat flow                      |  | heat flow =<br>heat capacity *<br>temperature<br>difference's<br>derivative            |

## 2. Example. Collector Machine

As an example of an electromechanical system we shall consider a system with commutator machines. A commutator machine is described by the following equations:

$$\begin{aligned} \varphi &= AX' + GJ + LJ', \\ T &= -AJ + BX' + WX'', \end{aligned} \tag{10}$$

or

$$\begin{aligned} b_1J' + c_1J + e_1X' &= \varphi, \\ c_2J + d_2X'' + e_2X' + h_2 &= 0, \end{aligned} \tag{11}$$

where

$X$  – rotation angle; in our notations it is an “outside” variable;

$\varphi$  - voltage across the commutator; in our notations it is a node potential;

$J$  – current of the commutator machine; in our notations it is the current of differentiating node;

$T = h_2$  - moment of force on the commutator machine shaft ,

$W = -d_2$  - moment of inertia of the commutator machine,

$G = c_1$  - winding resistance,

$L = b_1$  - winding inductance,

$A = e_1 = -c_2$  – a known coefficient (depending on the excitation current),

$B = -e_2$  - a known coefficient.

Commutator machines are connected by electrical circuits, and are placed at the nodes of this circuit; they are also connected by a mechanical circuit – a reducer system, including, in addition to commutator machines, the sources and the customers of the moment of force. So the system of equations for an electromechanical system should, generally speaking, include an equation for the moments of force in the system. However, the moments of forces on the shafts of commutator machines may be easily expressed by external sources and consumers of the moments of force. And then such electromechanical system in general may be described by a system of equations (4) with

$$Q = \begin{vmatrix} q \\ J \\ X \end{vmatrix}, \bar{E} = \begin{vmatrix} E - \rho N^T H \\ \rho H \\ h_2 \end{vmatrix}, \bar{M} = \begin{vmatrix} M & 0 & 0 \\ 0 & 0 & 0 \\ 0 & 0 & d_2 \end{vmatrix},$$

$$\bar{R} = \begin{vmatrix} (R + \rho N^T N) & 0 & 0 \\ (-\rho N) & b_1 & e_1 \\ 0 & 0 & e_2 \end{vmatrix}, \bar{S} = \begin{vmatrix} S & (-\rho N^T) & 0 \\ 0 & (c_1 + \rho) & 0 \\ 0 & c_2 & 0 \end{vmatrix}.$$

In the special case when one commutator machine is running idle and  $B = -e_2 = 0$ , the equations of the electromechanical system degenerate into one equation

$$T = WX'' \tag{12}$$

or



$$d_2 X'' + h_2 = 0. \quad (13)$$

The equation (12) follows from the principle of minimum of action

$$\int_0^T \left\{ E_k - E_p \right\} dt \rightarrow \min, \quad (14)$$

where

$$E_k = WX'^2/2 \text{ - kinetic energy,}$$

$$E_p = (-TX) \text{ - potential energy.}$$

In the considered case  $Q = X$ ,  $\bar{E} = h_2$ ,  $\bar{M} = d_2$ ,  $\bar{R} = 0$ ,  $\bar{S} = 0$  and the functionals (4.13) and (4.14) take the following form:

$$F_1 = \int_0^T \left\{ \frac{1}{2} d_2 (X_1'^2 - X_2'^2) - h_2 (X_1 - X_2) \right\} dt,$$

$$F_2 = \int_0^T \left\{ \frac{1}{2} (Y_1 Y_2' - Y_1' Y_2) - h_2 (Y_1 - Y_2) \right\} dt.$$

The optimization of these functionals leads to equation (13) and is equivalent to the optimization of functional (14), which leads to equation (12). Thus, in this particular case the minimum of action principle is equivalent to the presented principle. But the minimum of action principle is not applicable to the general case of electromechanical system.

### 3. More about Electric Circuits

Let us again consider an electric circuit with differential branches. Notice that a circuit of such configuration may be constructed also without bringing in the concept of differential branches. But before the computation it must be transformed into an unconditional electric circuit. There is, however, an exception – electric circuits, where

- 1) each node is connected by one (differential) branch with “ground”;
- 2) differential branches are not connected with other branches by mutual inductances.

In future we shall call such circuits grounded. Such circuits may be computed directly, without transforming them into unconditional circuits.

According to the above-stated, a grounded electric circuit may be described by the following equations system

$$\begin{cases} Mq'' + Rq' + Sq - E + N^T \varphi = 0, \\ a_1 J'' + b_1 J' + c_1 J + h_1 + \varphi = 0, \\ Nq' + H + J' = 0. \end{cases} \quad (15)$$

Excluding  $\varphi$ ,  $J$ , we get

$$\left( \begin{array}{l} Mq'' + Rq' + Sq - E + \\ N^T [a_1(Nq'' + H') + b_1(Nq' + H) + c_1(Nq + \hat{H}) - h_1] \end{array} \right) = 0,$$

which is equivalent to (7), where

$$\begin{aligned} Q &= q; \quad \bar{E} = E - N^T (a_1 H' + b_1 H + c_1 \hat{H} - h_1); \\ \bar{M} &= M + N^T a_1 N; \quad \bar{R} = R + N^T b_1 N; \quad \bar{S} = S + N^T c_1 N. \end{aligned}$$

Equation (7) may be used for computing a stationary mode according to formulas of the section 5.5 and for computing the reaction on voltage and current jumps using the maximization algorithm 3. It is important to mention that to do the latter the necessary condition is only (unlike the circuits considered in section 6.5), the presence of inductances in all nondifferential branches. Apparently it leads to a possibility of computing transient modes in grounded electric circuits (by the method described in section 6.6).

Let us now consider an electric circuit with Dennis transformers (see section 3.2):

$$\left\{ \begin{array}{l} Mq'' + Rq' + Sq - E + N^T \varphi + T\phi = 0, \\ a_1 J'' + b_1 J' + c_1 J + h_1 + \varphi = 0, \\ b_2 K' + h_2 + \phi = 0, \\ Nq' + H + J' = 0, \\ T^T q' + P + K' = 0. \end{array} \right. \quad (16)$$

Excluding from there  $\varphi$ ,  $\phi$ ,  $J$ ,  $K$ , we get

$$\left( \begin{array}{l} Mq'' + Rq' + Sq - E \\ + N^T [a_1(Nq'' + H') + b_1(Nq' + H) + c_1(Nq + \hat{H}) - h_1] \\ + T [b_2(T^T q' + P) - h_2] \end{array} \right) = 0, \quad (17)$$

which is equivalent to (7), where

$$\begin{aligned} Q &= q; \\ \bar{E} &= E - [N^T (a_1 H' + b_1 H + c_1 \hat{H} - h_1) + T(b_2 P - h_2)]; \\ \bar{R} &= R + N^T b_1 N + T_1 b_2 T_1^T; \\ \bar{M} &= M + N^T a_1 N; \end{aligned}$$

$$\bar{S} = S + N^T c_1 N. \tag{18}$$

Apparently, the matrices  $\bar{M}$ ,  $\bar{R}$ ,  $\bar{S}$  in general case are symmetric and of fixed sign. Therefore the method described in section 5.6. may be applied to the computation of electric circuit in stationary mode. But this computation method in the case of electric circuit with step excitations may be used only if the matrix  $\bar{M}$  is positive definite, which is unattainable in general case. That is why for computing the transient conditions it is essential for the electric circuit to be necessarily transformed into unconditional or grounded circuit.

**Example 1.** Consider an electric circuits in the form of ring line with  $n$  nodes ( $n$  is an even number) – see Fig. 1.

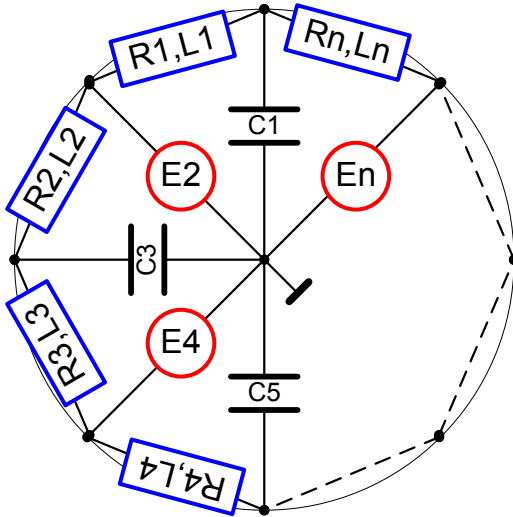

Fig. 1.

There are an inductance and a resistance connected between every pair of nodes. Between odd nodes and the “ground” there is a source of “jumping” voltage (switched on at the moment  $t=0$ ), and between even nodes and the “ground” there is a capacitance. Let us use the method described above to compute this circuit. From (15) we get

$$Mq'' + Rq' - E + N^T \varphi = 0, \quad c_1 J + h_1 + \varphi = 0, \quad Nq' + J' = 0.$$

Then, from (16) we get

$$Q = q; \quad \bar{E} = E + N^T h_1; \quad \bar{M} = M; \quad \bar{R} = R; \quad \bar{S} = N^T c_1 N.$$

It is easy to see that in this case the matrix

$$N = \left\{ \begin{array}{cccccc} 1 & -1 & 0 & 0 & \dots & 0 \\ 0 & 1 & -1 & 0 & \dots & 0 \\ 0 & 0 & 1 & -1 & \dots & 0 \\ \dots & \dots & \dots & \dots & \dots & \dots \\ -1 & 0 & 0 & 0 & \dots & 1 \end{array} \right\} n$$

←----- n ----->

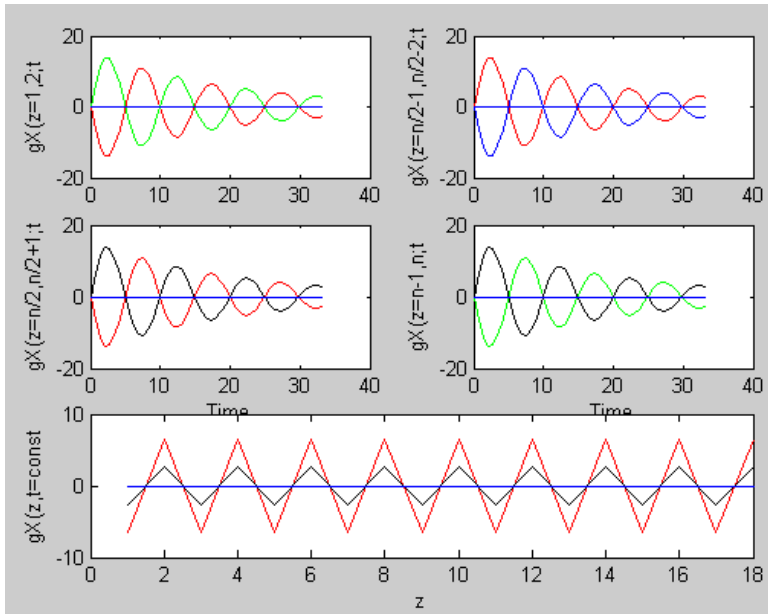

Fig. 2.

Fig. 2 shows the computation results with  $n=18$ ,  $L=10$ ,  $R=1$ ,  $S=2$ ,  $E=100$  (see also function `testDEJdlin2`). This figure depicts

- Graphs of variation with time of the currents within the two first elements of the circuit –  $gX(z=1,2; t)$ ;
- Graphs of variation with time of the currents within the four middle elements of the circuit –  $gX(z=n/2-1,n/2-2; t)$  and  $gX(z=n/2,n/2+1; t)$ ;
- Currents in all elements of the circuit at the first observation moment and at the end of observation interval -  $gX(z; t=const)$ .

**Example 2.** Consider an electric circuit in the shape of line with  $n$  nodes. At the line's beginning there is a source of "jumping" voltage (switched on at the moment  $t=0$ ). Between each pair of nodes there are a resistance and an inductance, and between each node and the "ground" there is a capacitance. We shall use for the computation of this circuit the formulas of Example 1. Fig. 3 shows the results of computation for  $n=(1,2,3,4)$ ,  $L=10$ ,  $R=1$ ,  $S=2$ ,  $E=100$  (see also function `testDEJdlin3`). This Figure shows the graphs of variation in time for each  $e$ -element of the electric circuit " $n, e$ "

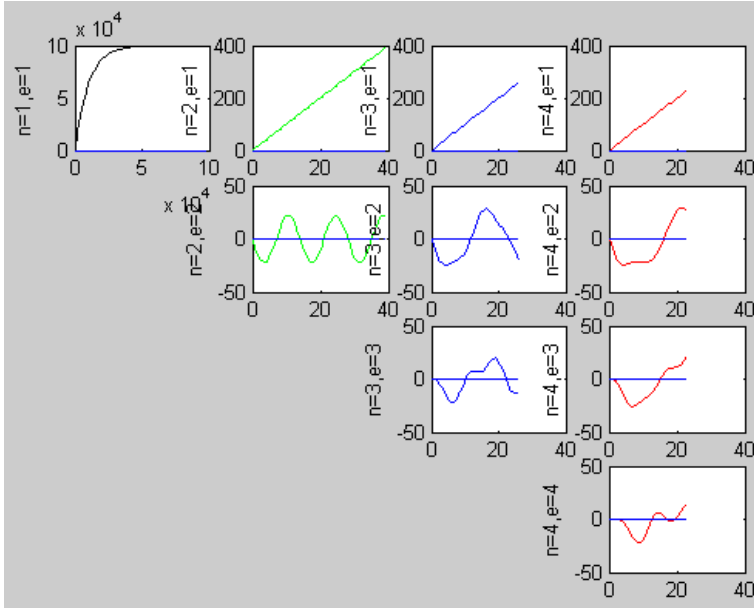

Fig. 3.

**Example 3.** Let us consider the electric circuit of Example 2, but without the inductances, and assuming that at the line's beginning there is a source of impulse voltage (switched on at the moment  $t=0$ ) in the form of Dirac function – for comparison see Example 6.6.9c. Let us use the formulas of Example 1 for this electric circuit computation. Fig. 3 shows the results of computation for  $n=(1,2,3,4)$ ,  $R=1$ ,  $S=2$ ,  $E=100$  (see also function `testDirakDlin`). This Figure shows the graphs of variation in time for each  $e$ -element of the electric circuit " $n, e$ "

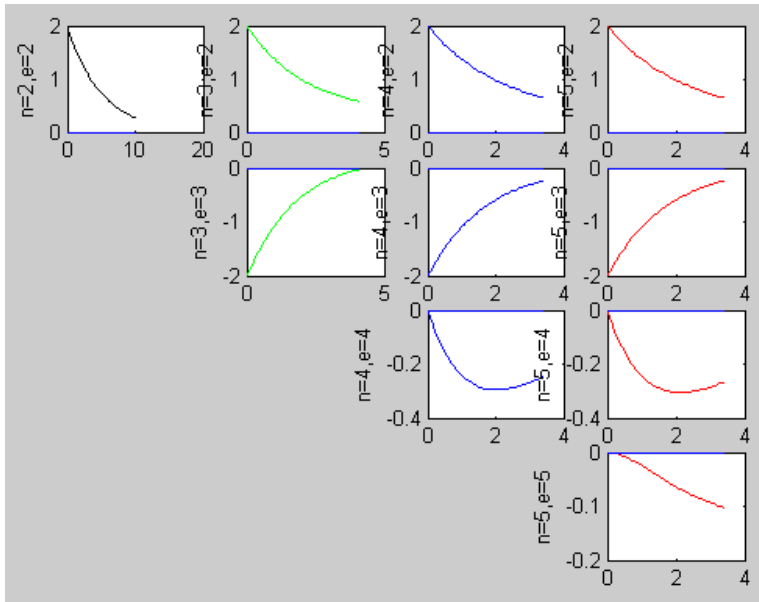

Fig. 4.

# Chapter 8. The Functional for Partial Differential Equations

---

## 1. Variational Optimum Principle for Electric Lines and Planes

Here the variational optimum principle for electromechanical systems is being applied for electric lines and planes [23]. A method of electric lines and planes computation is indicated. The lines and planes may be non-homogeneous, and complex loads and/or voltage sources may be connected to any of their points.

### 1.1. The equations of continuous electric line

It is known that a continuous electric line (*a long line*) is characterized by the following parameters:

$L$ ,  $C$ ,  $R$ ,  $G$  - inductance, capacitance, resistance and

conductivity of an element of line length,

$i$  - current along the line length element,

$u$  - voltage on the line length element,

$t$  - time,

$z$  - the line coordinates.

Now and further the derivatives in time are denoted by strokes. As is known, these parameters are connected by equations

$$\frac{\partial i}{\partial z} = Gu + C \frac{\partial u}{\partial t}, \quad (1)$$

$$\frac{\partial u}{\partial z} = Ri + L \frac{\partial i}{\partial t}. \quad (2)$$

From (1) it follows

$$\frac{\partial u}{\partial z} = \frac{1}{G} \left( \frac{\partial^2 i}{\partial z^2} - C \frac{\partial u'}{\partial z} \right). \quad (3)$$

Finally, combining (2, 3), we get:

$$\frac{1}{G} \left( \frac{\partial^2 i}{\partial z^2} - C \frac{\partial u'}{\partial z} \right) = Ri + Li'. \quad (4)$$

Thus, the electric line is described by (3, 4), which follow from (1, 2).

### 1.2. The equations of discrete electric line

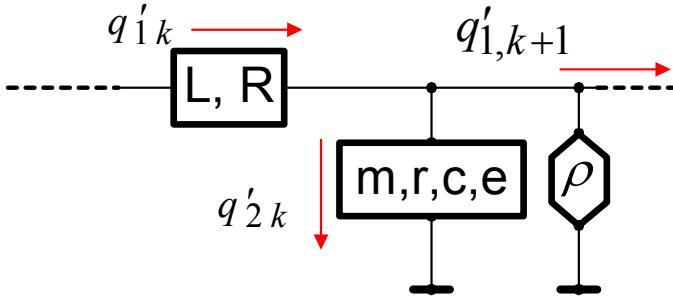

Fig. 1. A long line.

We shall call an electric line composed of finite elements (unlike the elements whose size is related to the line length element), a *discrete electric line* - see also Fig 1, where

$L, R$  - inductance and resistance of the line length element,

$m, c, r, e$  - inductance, capacitance, resistance and voltage, connected serially between a line length element and zero potential - "vertical" line element,

$1/\rho$  - conductivity between line length element and zero potential,

$q'_1$  - current along line length element,

$q'_2$  - current of a vertical line element.

According to the above stated, the electric circuit of a discrete electric line may be presented by an unconditional electric circuit consisting of 1-branches - length elements with parameters  $L, R$  and 2-branches - branches with parameters  $m, S = 1/c, r, e$ . The resistances  $\rho$  are connected between the nodes of this line and zero potential. Let us consider  $n$ -dimensional vectors



$$q_1 = \begin{vmatrix} q_{1,1} \\ \dots \\ q_{1,k} \\ q_{1,k+1} \\ \dots \\ q_{1,n} \end{vmatrix}, \quad q_2 = \begin{vmatrix} q_{2,1} \\ \dots \\ q_{2,k} \\ q_{2,k+1} \\ \dots \\ q_{2,n} \end{vmatrix}, \quad q_1 = \begin{vmatrix} q_{1,1} \\ \dots \\ q_{1,k} \\ q_{1,k+1} \\ \dots \\ q_{1,n} \end{vmatrix}, \quad q_2 = \begin{vmatrix} q_{2,1} \\ \dots \\ q_{2,k} \\ q_{2,k+1} \\ \dots \\ q_{2,n} \end{vmatrix} \quad \text{and}$$

vector  $q = \begin{vmatrix} q_1 \\ q_2 \end{vmatrix}$ . Then the parameters of electric circuit may be presented as

$$\bar{S} = \begin{vmatrix} 0 & 0 \\ 0 & S \end{vmatrix}, \quad (1)$$

$$\bar{M} = \begin{vmatrix} L & 0 \\ 0 & m \end{vmatrix}, \quad (2)$$

$$R_d = \begin{vmatrix} R & 0 \\ 0 & r \end{vmatrix}, \quad (3)$$

$$\bar{R} = (R_d + \rho \cdot N^T N), \quad (4)$$

$$\bar{E} = \begin{vmatrix} 0 \\ e \end{vmatrix}, \quad (5)$$

$$\begin{aligned} S &= \text{diag}(S_1 \dots S_k \dots S_n), & L &= \text{diag}(L_1 \dots L_k \dots L_n), \\ m &= \text{diag}(m_1 \dots m_k \dots m_n), & R &= \text{diag}(R_1 \dots R_k \dots R_n), \\ r &= \text{diag}(r_1 \dots r_k \dots r_n), & e^T &= \{e_1 \dots e_k \dots e_n\}. \end{aligned}$$

The First Kirchhoff Law has the form

$$q'_{1,k} - q'_{1,k+1} - q'_{2,k} = 0. \quad (6)$$

So the incidences matrix is:

$$N = |N_2 \quad -D_1|, \quad (7)$$

where

$D_1$  - quadratic  $n \times n$  diagonal identity matrix,

$N_2$  - band quadratic  $n \times n$  matrix

$$N_2 = \left\{ \begin{array}{cccccc|c} 1 & -1 & 0 & 0 & \dots & 0 & \\ 0 & 1 & -1 & 0 & \dots & 0 & \\ 0 & 0 & 1 & -1 & \dots & 0 & \\ \dots & \dots & \dots & \dots & \dots & \dots & \\ 0 & 0 & 0 & 0 & \dots & 1 & \\ \hline & & & & & & n \end{array} \right\} \quad (8)$$

The following matrix product is a quadratic cell-wise matrix

$$N^T N = \begin{vmatrix} N_1 & -N_2 \\ -N_2^T & D_1 \end{vmatrix}, \quad (9)$$

where  $N_1$  is a band quadratic  $n \times n$  matrix

$$N_1 = N_2^T N_2 = \begin{vmatrix} 2 & -1 & & & & & \\ -1 & 2 & -1 & & & & \\ & -1 & 2 & -1 & & & \\ & & & \dots & \dots & \dots & \\ & & & & -1 & 2 & -1 \\ & & & & & -1 & 2 & -1 \\ & & & & & & -1 & 2 \end{vmatrix} \quad (10)$$

From (4) and (7) follows

$$\bar{R} = \begin{vmatrix} (R + \rho \cdot N_1) & (-\rho \cdot N_2) \\ (-\rho \cdot N_2^T) & (r + \rho \cdot D_1) \end{vmatrix}. \quad (11)$$

In this case the functional (4.12) takes the form

$$F(q) = \int_0^T \left\{ \begin{array}{l} q_2^T S q_2 - q_2'^T m q_2' + q^T \bar{R} q \\ -q_1'^T L q_1' - E q_2 \end{array} \right\} dt, \quad (12)$$

or, taking into account (11),

$$F(q) = \int_0^T \left\{ \begin{array}{l} q_2^T S q_2 - q_2'^T m q_2' - q_1'^T L q_1' \\ + q_1^T R q_1' + q_2^T r q_2' + \rho q_1^T N_1 q_1' \\ + 2\rho q_2^T N_2^T q_1' + \rho q_2^T q_2' - E^T q_2 \end{array} \right\} dt, \quad (13)$$

The gradient (4.1) in this case will take the form  $p = \begin{pmatrix} p_1 \\ p_2 \end{pmatrix}$ , where

$$p_1 = Lq_1'' + Rq_1' + \rho N_1 q_1' - \rho N_2 q_2' \tag{14}$$

$$p_2 = \rho \left( N_2^T q_1' + q_2' \right) + Sq_2 + mq_2'' + rq_2' - E \tag{15}$$

Let us denote by symbols  $q_{1\Rightarrow}$ ,  $q_{1\Leftarrow}$  vectors shifted along the line to the right or to the left, accordingly, with respect to  $q_1$ :

$$\text{if } q_1 = \begin{pmatrix} q_{1,1} \\ q_{1,2} \\ q_{1,3} \\ \dots \\ q_{1,n-1} \\ q_{1,n} \end{pmatrix}, \text{ then } q_{1\Rightarrow} = \begin{pmatrix} 0 \\ q_{1,2} \\ q_{1,3} \\ q_{1,4} \\ \dots \\ q_{1,n-1} \end{pmatrix}, \quad q_{1\Leftarrow} = \begin{pmatrix} q_{1,2} \\ q_{1,3} \\ q_{1,4} \\ \dots \\ q_{1,n-1} \\ 0 \end{pmatrix}.$$

Looking at the matrices  $N_1$  and  $N_2$ , we may notice that

$$N_1 q_1' = (2q_1' - q_{1\Rightarrow}' - q_{1\Leftarrow}'), \tag{16}$$

$$N_2 q_1' = (q_1' - q_{1\Rightarrow}'), \tag{17}$$

$$N_2 q_2' = (q_2' - q_{2\Rightarrow}'). \tag{18}$$

**Example 1.** Consider electric line with parameters  $n = 50$ ,  $\rho = 53$ ,  $L = 0.9$ ,  $m = 1.1$ ,  $R = 0.8$ ,  $r = 1$ ,  $S = 0.3$ . Let us assume that at the beginning and at the end of this line sinusoidal voltage sources are connected  $E_1 = -150 + 200j$ ,  $E_n = 200 - 150j$  accordingly. After the formation of matrices  $\bar{M}$ ,  $\bar{S}$ ,  $\bar{R}$  and vector  $\bar{E}$  the computation of this line may be performed directly by using the **SinLin** function, cited in Example 5.5.1. Fig. 1 displays a graph of variation of some of the currents during the iterative computation process (see also function **testDLIN**). To be more exact, on the complex plane the mentioned graphs for currents  $q'_k$ ,  $k = 1, 2, 25, 48, 49$ . are depicted. The unbroken line  $q_1 - q_2 - q_{25} - q_{48} - q_{49}$  describes stationary values of the currents  $q'_k$ .

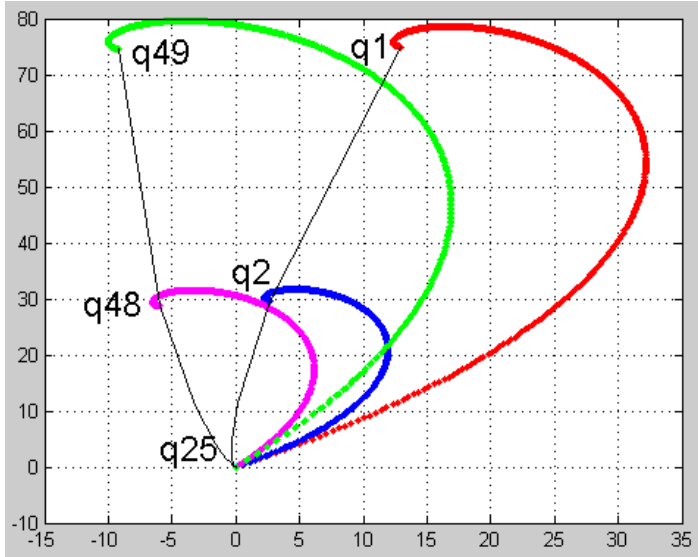

Fig. 1.

### 1.3. The Functional for Continuous Electric Line

Passing from the elements of discrete electric line to the line length differentials, we may consider the vector-function  $q$ , where each component is a function of time  $q_k = q_k(t)$ , as a function of the coordinate of the line  $z$  and time  $t$ , that is  $q = q(z, t)$ . Then

$$(2q' - q'_{\Rightarrow} - q'_{\Leftarrow}) = -\frac{\partial^2 q'(z, t)}{\partial z^2},$$

$$(q' - q'_{\Rightarrow}) = -\frac{\partial q'(z, t)}{\partial z}$$

and, taking into account (2.16-2.18), we get

$$N_1 \cdot q'_1 = -\frac{\partial^2 q'_1(z, t)}{\partial z^2}, \tag{1}$$

$$N_2 \cdot q'_2 = -\frac{\partial q'_2(z, t)}{\partial z}, \tag{2}$$

$$N_2^T \cdot q'_1 = -\frac{\partial q'_1(z, t)}{\partial z}. \tag{3}$$

Also

$$p_1 = Lq_1'' + Rq_1' - \rho \frac{\partial^2 q_1'}{\partial z^2} + \rho \frac{\partial q_2'}{\partial z}, \quad (4)$$

$$p_2 = \rho \left( \frac{\partial q_1'}{\partial z} + q_2' \right) + Sq_2 + mq_2'' + rq_2' - E. \quad (5)$$

Let us denote  $u = Sq_2$ ,  $i = q_1'$ . Then from (4, 5) with  $p_1 = 0$ ,  $p_2 = 0$  there follow (1.3, 1.4). Further we have

$$q_1^T N_1 q_1 = \oint_z q_1 \frac{\partial^2 q_1}{\partial z^2} dz, \quad q_2^T N_2^T q_1' = \oint_z \frac{\partial q_2}{\partial z} q_1' dz.$$

At that (2.13) assumes the form

$$F(q) = \int_0^T \left[ \int_0^Z \left\{ \begin{aligned} &Sq_2^2 - mq_2'^2 - Lq_1'^2 \\ &+ Rq_1 q_1' + rq_2 q_2' - \rho q_1 \frac{\partial^2 q_1'}{\partial z^2} \\ &+ 2\rho q_1' \frac{\partial q_2}{\partial z} + \rho q_2 q_2' - Eq_2 \end{aligned} \right\} dz \right] dt, \quad (6)$$

Thus, similarly to the Theorem 4.1, for an electric line the following theorem is valid:

**Theorem 1.** The movement in functional (6) in the direction (4.10), where the gradient  $p = \begin{vmatrix} p_1 \\ p_2 \end{vmatrix}$  is determined by (4, 5), ends on a stationary

value of the function  $q = \begin{vmatrix} q_1 \\ q_2 \end{vmatrix}$ , and the equation of this stationary value is

$$(4, 5), \text{ where } \begin{vmatrix} p_1 = 0 \\ p_2 = 0 \end{vmatrix}.$$

Thus, a continuous electric line may be computed with the aid of algorithm 5.1. The electric line may be non-homogeneous and complex loads and/or voltage sources may be connected to any point of this line.

For the computation of continuous electric line with voltages of the form of interoperable functions, the formula (5.3.7) may be used. In our case this formula transforms to:

$$\Delta g = \frac{-j\omega b_p}{b_s - \omega^2 b_m + j\omega b_r} p; \tag{7}$$

$$b_p = \int_0^T p^T p dt = \int_0^Z \int_0^T (p_1^2 + p_2^2) dt dz;$$

$$b_s = \int_0^T p^T \bar{S} p dt = \int_0^Z \int_0^T S p_2^2 dt dz;$$

$$b_m = \int_0^T p^T \bar{M} p dt = \int_0^Z \int_0^T L p_1^2 dt dz + \int_0^Z \int_0^T m p_2^2 dt dz; \tag{8}$$

$$b_r = \int_0^T p^T \bar{R} p dt = \int_0^Z \int_0^T \left( R p_1^2 - \rho p_1 \frac{d^2 p_1}{dz^2} + 2\rho p_1 \frac{dp_2}{dz} + (r + \rho) p_2^2 \right) dt dz.$$

In particular, for sinusoidal functions we have:

$$p_1 = -\omega^2 L q_1 + j\omega R q_1 - j\omega \rho \frac{d^2 q_1}{dz^2} + j\omega \rho \frac{dq_2}{dz}, \tag{9}$$

$$p_2 = S q_2 - \omega^2 m q_2 + j\omega(r + \rho) q_2 + j\omega \rho \frac{dq_1}{dz} - E, \tag{10}$$

**Example 5.** If the function  $E(z) = const$ , then on the first iteration we get  $p_1 = 0$ ,  $p_2 = E$ . Substituting it to the previous formulas and reducing them by  $\int_0^Z \int_0^T p_2^2 dt dz$ , we find:

$$\Delta g_1 = 0, \quad \Delta g_2 = \frac{-j\omega}{S - \omega^2 m + j\omega(r + \rho)} p_2$$

or

$$g_1 = 0, \quad g_2 = \frac{E}{S/j\omega + j\omega m + (r + \rho)}.$$

This is the final and evident result.

**Example 6.** Let us consider the case when the voltage is determined as twice differentiable continuous complex function of the coordinate  $z$ , namely, exponential polynomials of real and imaginary parts of complex function. Formulas (7-10) may be used directly for the

computation, operating with power series and getting the result also in the form of power series. For these calculations we shall use functions. The notations used there are clear from previous context.

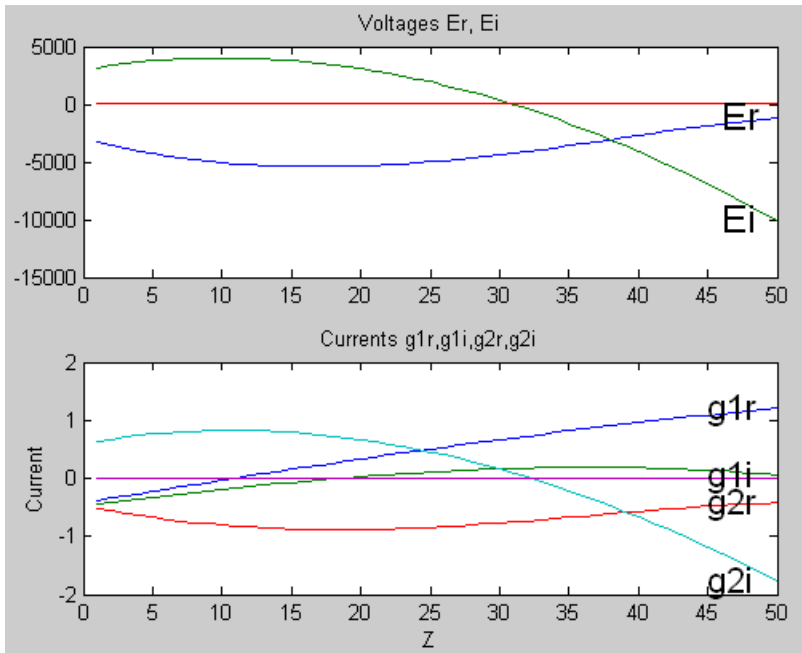

Fig. 2.

Let us apply the function `SinLinDLNP` to the computation of continuous electric line with parameters

$$n = 50, \rho = 5555, L = 0.9, m = 1.1, R = 0.8, r = 1, S = 0.3.$$

Let us assume that to this line a voltage is applied, whose real and imaginary parts are 5-term series with coefficients:

$$Er = [-3000, -300, 0, -0.03, -0.0007];$$

$$Ei = [ 3000, 200, -10, 0.01, 0.0001].$$

Using the above indicated functions we shall find the currents also in the form of 5-term series with the following coefficients:

$$g1r = -0.4190, 0.0395, -0.0001, -0.0000, 0.0000$$

$$g1i = -0.4743, 0.0300, -0.0001, -0.0000, 0.0000$$

$$g2r = -0.4656, -0.0488, 0.0016, -0.0000, -0.0000$$

$$g2i = 0.5978, 0.0421, -0.0020, 0.0000, 0.0000$$

This result will be obtained after the third iteration with the precision of 0.0003. Fig. 2 presents a graph of these voltages and currents variation depending on the coordinate  $z$  (see also function `test0`).

In the case when the function  $E(z)$  is not twice differentiable, the derivatives must be calculated with the aid of numerical differentiation.

From (1, 2, 3) it follows that  $\frac{\partial^2 q_1}{\partial z^2} = -N_1 \cdot q_1$ ,  $\frac{\partial q_2}{\partial z} = -N_2 \cdot q_2$ ,

$\frac{\partial q_1}{\partial z} = -N_2^T \cdot q_1$ , where the matrices  $N_1, N_2$  are determined from (1.8, 1.10), and  $n$  – the number of intervals that the argument of the differentiated function is divided into .

As in theorem 4.1.1 for a continuous electric line we can determine two secondary functionals (as regarding the functional (6)). Let us consider the first of those secondary functionals –functional of the form

$$F(x, y) = \frac{1}{2} \int_0^T \int_0^Z \left\{ \begin{array}{l} -L \left( \left( \frac{dx_1}{dt} \right)^2 - \left( \frac{dy_1}{dt} \right)^2 \right) \\ -m \left( \left( \frac{dx_2}{dt} \right)^2 - \left( \frac{dy_2}{dt} \right)^2 \right) \\ + R \left( x_1 \frac{dy_1}{dt} - y_1 \frac{dx_1}{dt} \right) \\ -\rho \left( x_1 \frac{d^3 y_1}{dz^2 dt} - y_1 \frac{d^3 x_1}{dz^2 dt} \right) \\ + 2\rho \left( x_2 \frac{d^2 x_1}{dtdz} - y_2 \frac{d^2 y_1}{dtdz} \right) \\ S(x_2^2 - y_2^2) \\ + (r + \rho) \left( x_2 \frac{dy_2}{dt} - y_2 \frac{dx_2}{dt} \right) \\ - E(x_2 - y_2) \end{array} \right\} dz dt \quad (11)$$

In this functional the variables are the functions  $x_1, x_2, y_1, y_2$  of two independent variables  $t$  and  $z$ . The variations of this functional by the functions  $x_1(t, z), y_1(t, z)$  are accordingly



$$p_{x1} = L \frac{d^2 x_1}{dt^2} + R \frac{dy_1}{dt} - \rho \frac{d^3 y_1}{dz^2 dt} + \rho \frac{d^2 x_2}{dtdz},$$

$$p_{y1} = -L \frac{d^2 y_1}{dt^2} - R \frac{dx_1}{dt} + \rho \frac{d^3 x_1}{dz^2 dt} - \rho \frac{d^2 y_2}{dtdz}.$$

Hence it follows that

$$p_1 = p_{x1} - p_{y1} = L \frac{d^2 q_1}{dt^2} + R \frac{dq_1}{dt} - \rho \frac{d^3 q_1}{dz^2 dt} + \rho \frac{d^2 q_2}{dtdz} \quad (12)$$

where  $q_1 = x_1 + y_1$ , which agrees with formula (4). Similarly, the variations of this functional by the functions  $x_2(t, z)$ ,  $y_2(t, z)$  are accordingly

$$p_{x2} = Sx_2 + m \frac{d^2 x_2}{dt^2} + (r + \rho) \frac{dy_2}{dt} + \rho \frac{d^2 x_1}{dtdz} - \frac{E}{2},$$

$$p_{y2} = -Sy_2 - m \frac{d^2 y_2}{dt^2} - (r + \rho) \frac{dx_2}{dt} - \rho \frac{d^2 y_1}{dtdz} + \frac{E}{2}.$$

Hence it follows that

$$p_2 = p_{x2} - p_{y2} = Sq_2 + m \frac{d^2 q_2}{dt^2} + (r + \rho) \frac{dq_2}{dt} + \rho \frac{d^2 q_1}{dtdz} - E, \quad (13)$$

where  $q_2 = x_2 + y_2$ , which agrees with formula (5). Thus, the necessary conditions of the extremum of functional (6a) are the conditions  $\left| \begin{matrix} p_1 = 0 \\ p_2 = 0 \end{matrix} \right|$ , where gradient  $p = \left| \begin{matrix} p_1 \\ p_2 \end{matrix} \right|$  is determined from (4, 5) or (which is the same) from (12, 13).

Putting aside the the physical model, the obtained results may be considered as a method for finding a solution of equations system  $p = 0$ , where  $p = \left| \begin{matrix} p_1 \\ p_2 \end{matrix} \right|$  is determined from (12, 13).

**Example 7.** Let  $E(t, z) = E_o \exp j(\omega t + \sigma z)$ . Consider an iterative process of computing the functions  $q_1(t, z)$   $q_2(t, z)$  according to (11, 12). On the first iteration we shall find  $p_1 = 0$ ,  $p_2 = -E$ . According to (8, 7) we compute:

$$b_p = \int_0^Z \int_0^T E^2 dt dz; \quad b_s = S \int_0^Z \int_0^T E^2 dt dz; \quad b_m = m \int_0^Z \int_0^T E^2 dt dz;$$

$$b_r = (r + \rho) \int_0^Z \int_0^T E^2 dt dz; \quad \frac{dq}{dt} = \frac{-j\omega b_p}{b_s - \omega^2 b_m + j\omega b_r} p.$$

Hence it follows that on the first iteration

$$q_1 = 0, \quad q_2 = wE, \quad w = \frac{1}{S - \omega^2 m + j\omega(r + \rho)}.$$

On the second iteration we find

$$p_1 = \rho \frac{d^2 q_2}{dt dz} = -\omega \sigma \rho w E = vE, \quad v = -\omega \sigma \rho w E;$$

$$p_2 = S q_2 - \omega^2 m q_2 + j\omega(r + \rho) q_2 - E = \frac{q_2}{w} - E = 0.$$

According to (8, 7) we compute:

$$b_p = v^2 \int_0^Z \int_0^T E^2 dt dz; \quad b_s = 0; \quad b_m = Lv^2 \int_0^Z \int_0^T E^2 dt dz;$$

$$b_r = (R + \rho \sigma^2) \int_0^Z \int_0^T E^2 dt dz.$$

Hence it follows that on the second iteration

$$q_1 = \frac{-p_1}{-\omega^2 L + j\omega(R + \rho \sigma^2)} = yE,$$

$$y = \frac{v}{\omega^2 L - j\omega(R + \rho \sigma^2)}; \quad q_2 = 0.$$

On the third iteration we find

$$p_1 = -\omega^2 L q_1 + j\omega R q_1 + j\omega \sigma^2 \rho q_1 = -vE;$$

$$p_2 = -\omega \sigma \rho q_1 - E = -(\omega \sigma \rho y + 1)E;$$

and so on. Thus, on any iteration  $q_1 = \bar{q}_1 E$ ,  $q_2 = \bar{q}_2 E$ , where

$\bar{q}_1$ ,  $\bar{q}_2$  are complex numbers, varying in the iterative process. The function  $E(t, z) = E_0 \exp j(\omega t + \sigma z)$  may be excluded from all the formulas. Then we get

$$p_1 = -\omega^2 \bar{q}_1 + j\omega R \bar{q}_1 + j\omega \sigma^2 \rho \bar{q}_1 - \omega \sigma \rho \bar{q}_2,$$

$$p_2 = S \bar{q}_2 - \omega^2 m \bar{q}_2 + j\omega(r + \rho) \bar{q}_2 - \omega \sigma \rho \bar{q}_1 - E_0,$$

$$b_p = (p_1^2 + p_2^2) \quad b_s = Sp_2^2; \quad b_m = (Lp_1^2 + mp_2^2)$$

$$b_r = (Rp_1^2 + \sigma^2 \rho p_1^2 - 2j\sigma \rho p_1 p_2 + (r + \rho)p_2^2)$$

These formulas plus the formula (7) are sufficient for computing the final values of  $\bar{q}_1, \bar{q}_2$ . The function Volna system realizes these formulas. Fig. 3 presents the graphs of the variables  $qq1 = \bar{q}_1, qq2 = \bar{q}_2$  variation during an iterative process with  $ro=0.15$ ;  $LL=0.9$ ;  $mm=1.1$ ;  $RR=0.8$ ;  $SS=0.3$ ;  $rr=1$ ;  $\omega=628$ ;  $\sigma=127$ ;  $E0=1000$ ;  $\max K=93$ .

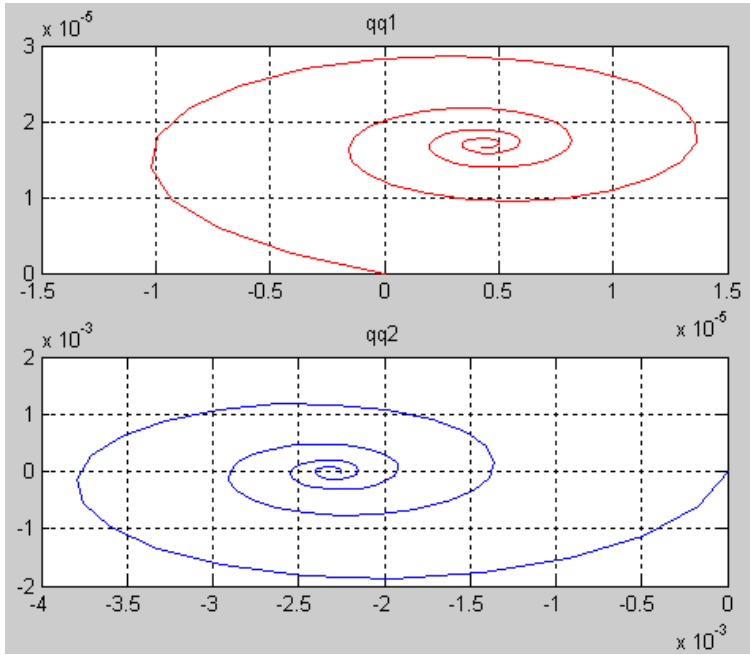

Fig. 3.

#### 1.4. The Functional for Continuous Electric Plane

The equations of continuous electric line with coordinate  $z$  may be generalized in natural way to an electric plane with coordinates  $z, y$ . It may be shown that for electric plane the gradient is represented by the equations

$$p_1 = Lq_1'' + Rq_1' - \rho \frac{\partial^2 q_1'}{\partial z^2} - \rho \frac{\partial^2 q_2'}{\partial y^2},$$

$$p_2 = \rho \left( \frac{\partial q_1'}{\partial z} + \frac{\partial q_1'}{\partial y} + q_2' \right) + S q_2 + m q_2'' + r q_2' - E,$$

and the functional takes the form

$$F(q) = \int_0^T \left\{ \int_z \left\{ \int_y \left[ S q_2^2 - m q_2'^2 - L q_1'^2 + R q_1 q_1' + r q_2 q_2' - \rho q_1 \left( \frac{\partial^2 q_1'}{\partial z^2} + \frac{\partial^2 q_1'}{\partial y^2} \right) + 2 \rho q_1' \left( \frac{\partial q_2}{\partial z} + \frac{\partial q_2}{\partial y} \right) + \rho q_2 q_2' - E q_2 \right] \right\} dy \right\} dz \left. \right\} dt.$$

So an electric plane may be also computed with the aid of algorithm 5.1. The electrical plane may be non-homogeneous with connected complex loads and/or voltage sources.

## 2. An Electric Line for Poisson Equation Modeling

### 2.1. Introduction

Below it will be shown that a certain electric circuit is a model of Poisson equation [24]. In this electric circuit a quadratic functional is being minimized, with respect to the current function as a function of three arguments. The functional has a global absolute minimum, and the stationary mode of the current function is described by Poisson equation. The computation of this electrical circuit, and consequently, finding the solution of Poisson equation amounts to gradient descent along the mentioned functional. This method is applicable for the computations of homogeneous and non-homogeneous mediums. Moreover, this method allows to find analytical expression of the sought function, if the initial functions were expressed analytically.

Let us denote:

$$\Delta U = \frac{\partial^2 U}{\partial x^2} + \frac{\partial^2 U}{\partial y^2} + \frac{\partial^2 U}{\partial z^2}, \quad (1)$$

where  $U$  is a function of arguments  $x, y, z$ . The Laplace and Poisson equations with respect to function  $U$ , as is well known [14], have accordingly the following form:

$$\Delta U = 0, \quad (2)$$

$$\Delta U = f(x, y, z), \quad (3)$$

where  $f(x, y, z)$  is a known function. The equation (3) may be called the Poisson equation for *homogeneous medium*. Let us consider also the equation

$$\alpha(x, y, z) \frac{\partial^2 U}{\partial x^2} + \beta(x, y, z) \frac{\partial^2 U}{\partial y^2} + \lambda(x, y, z) \frac{\partial^2 U}{\partial z^2} = f(x, y, z), \quad (4)$$

where  $\alpha(x, y, z), \beta(x, y, z), \lambda(x, y, z), f(x, y, z)$  are known functions. This equation may be called the Poisson equation for *non-homogeneous medium*.

The named equations are widely used in engineering, and thus the search for a speedy method of their solution is of great interest. Below we shall show that a certain electric circuit is a model of Poisson equation. So the solution of Poisson equation turns into the problem of finding the absolute global minimum of a certain functional.

In an unconditional electric circuit without reactive elements the following function is being minimized

$$F(i) = \frac{1}{2} \cdot i^T \bar{R} \cdot i - \bar{E}^T i, \quad (1)$$

where

$$\bar{R} = R + \rho \cdot \left( N^T \cdot N + T \cdot T^T \right), \quad (2)$$

$$\bar{E} = E - \rho \cdot \left( H^T N + V^T T^T \right), \quad (3)$$

$N$  - the incidence matrix,

$T$  - the DT transformation coefficients matrix,

$H$  - the vector of node current sources,

$V$  - the vector of node current sources in transformer nodes,

$E$  - the vector of voltage sources in the circuit branches,

$R$  - the diagonal matrix of resistances in the circuit branches,

$1/\rho$  - the conductivity between the node and zero potential.

The necessary condition of the absolute minimum of function (1) is an equation

$$\bar{R} \cdot i - \bar{E} = 0, \tag{4}$$

and the function (1) minimum may be found by gradient descent along the gradient

$$p = \bar{R} \cdot i - \bar{E}, \tag{5}$$

The optimal step size is determined from the condition

$$a = \frac{p^T p}{p^T \bar{R} \cdot p} \tag{6}$$

### 2.2. The Equations of a Discrete Electric Line

We shall call an electrical line composed of finite elements (unlike the elements whose value is related to an element of line length) a *discrete electric line*.

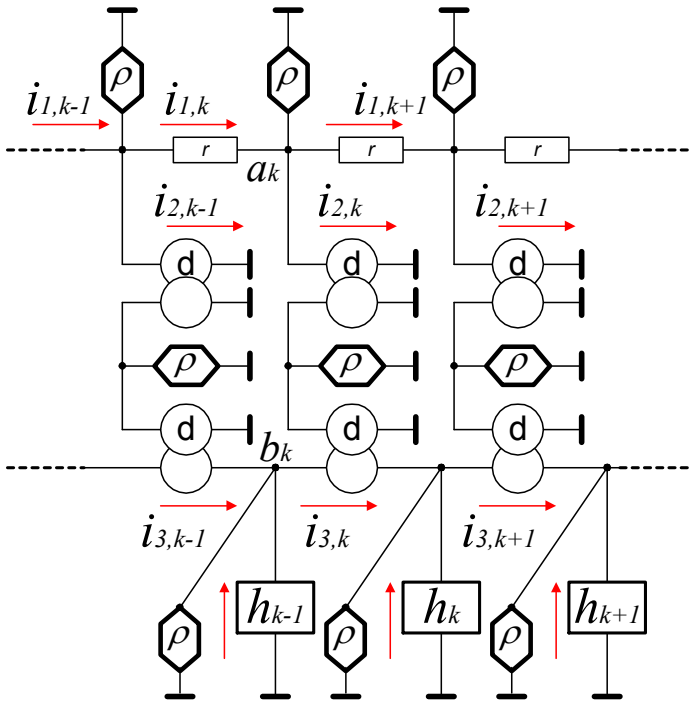

Fig. 1. A Long Line

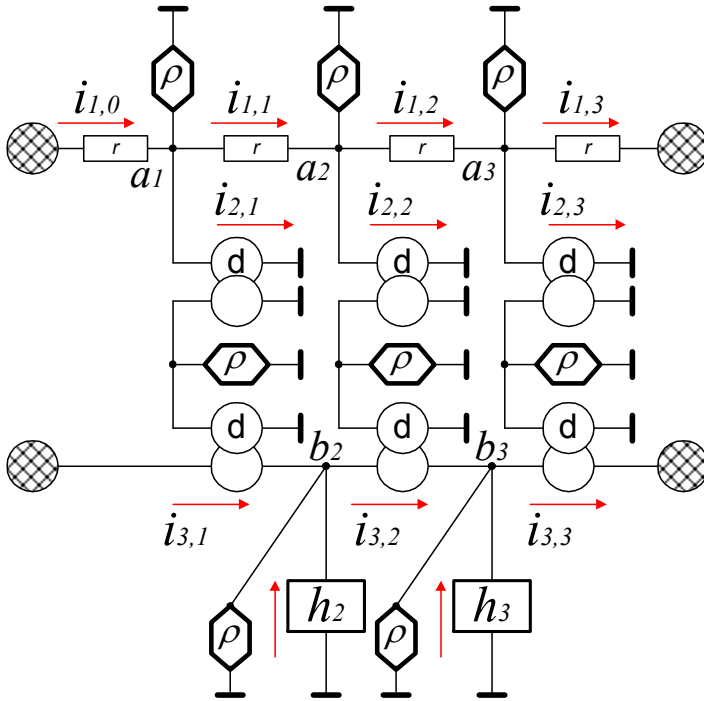

Fig. 2. Boundary Conditions

Fig. 1 shows a two-wire discrete electric line, where  $a$ ,  $b$  - nodes of the first and second line, accordingly,

$1/\rho$  - the conductivity between the node and zero potential,

$h$  - the source of the same name [21],

$d$  - the Dennis transformer with an unite transformation coefficient,

$r$  - the resistance of the first line length element,

$i_1$  - the current within the first line length element,

$i_2$  - the primal current of the Dennis transformer,

$i_3$  - the secondary current of the Dennis transformer.

There are singularities at the ends of the line. Take for illustration an electric line with three nodes – see Fig. 2, where the end current sources  $i_{1,0}$ ,  $i_{1,n}$ ,  $i_{3,1}$ ,  $i_{3,n}$  are depicted by hatched circles. Some of them may be absent, but it does not mean that the respective currents are equal to zero.

To analyze the two-wire discrete electric line we shall use the method used above for analyzing the one-wire discrete electric line. According to

this, the electric circuit of the discrete electric line may be represented by an unconditional electric circuit. Consider  $n$ -dimensional vectors

$$i_1 = \begin{pmatrix} i_{1,0} \\ \dots \\ i_{1,k} \\ i_{1,k+1} \\ \dots \\ i_{1,n} \end{pmatrix}, \quad i_2 = \begin{pmatrix} i_{2,1} \\ \dots \\ i_{2,k} \\ i_{2,k+1} \\ \dots \\ i_{2,n} \end{pmatrix}, \quad i_3 = \begin{pmatrix} i_{3,1} \\ \dots \\ i_{3,k} \\ i_{3,k+1} \\ \dots \\ i_{3,n} \end{pmatrix},$$

$$i = \begin{pmatrix} i_1 \\ i_2 \\ i_3 \end{pmatrix}, \quad h = \begin{pmatrix} h_1 \\ \dots \\ h_k \\ \dots \\ h_n \end{pmatrix}, \quad H^T = \begin{pmatrix} 0_1 \\ 0_2 \\ \dots \\ 0_{2n} \\ h \end{pmatrix}, \quad R = \text{diag}(r_1 \dots r_k \dots r_n).$$

The First Kirchhoff Law for nodes is:

$$i_{1,k} - i_{1,k+1} - i_{2,k} = 0, \tag{1}$$

$$i_{3,k} - i_{3,k+1} + h_k = 0. \tag{2}$$

So the incidence matrix has the form:

$$N = \begin{bmatrix} \overbrace{(N_2)}^n & \overbrace{(-D_1)}^n & \overbrace{(0)}^n \\ \overbrace{(0)}^n & \overbrace{(0)}^n & \overbrace{(N_2)}^n \end{bmatrix} \begin{matrix} n \\ n \end{matrix} \tag{3}$$

where the dimensions are given, and

$D_1$  - quadratic  $n \times n$  diagonal identity matrix,

$N_2$  - band matrix of the form

$$N_2 = \begin{pmatrix} -1 & 0 & 0 & \dots & 0 & 0 \\ 1 & -1 & 0 & \dots & 0 & 0 \\ 0 & 1 & -1 & \dots & 0 & 0 \\ \dots & \dots & \dots & \dots & \dots & \dots \\ 0 & 0 & 0 & \dots & 1 & -1 \end{pmatrix} \tag{4}$$

The following product is a quadratic partitioned matrix



$$N^T N = \begin{array}{c} \left[ \begin{array}{ccc} \begin{array}{c} \boxed{(N_1)} \\ \boxed{(-N_2)} \\ \boxed{(0)} \end{array} & \begin{array}{c} \boxed{(-N_2^T)} \\ \boxed{(D_1)} \\ \boxed{(0)} \end{array} & \begin{array}{c} \boxed{(0)} \\ \boxed{(0)} \\ \boxed{(N_1)} \end{array} \end{array} \right] \begin{array}{l} n \\ n \\ n \end{array} \\ \begin{array}{ccc} n & n & n \end{array} \end{array} \quad (5)$$

where  $N_1$  - band quadratic matrix of the form

$$N_1 = \begin{array}{c} \left| \begin{array}{cccc} 2 & -1 & & \\ -1 & 2 & -1 & \\ & -1 & 2 & -1 \\ & & \dots & \dots & \dots \\ & & & -1 & 2 & -1 \\ & & & & -1 & 2 & -1 \\ & & & & & -1 & 2 \end{array} \right| \end{array} \quad (6)$$

The DT matrix has to meet the condition

$$T^T i = 0 \quad (7)$$

and thus has the form

$$T^T = \begin{vmatrix} 0 & D_1 & -D_1 \end{vmatrix}. \quad (8)$$

At that

$$T \cdot T^T = \begin{vmatrix} 0 & 0 & 0 \\ 0 & D_1 & -D_1 \\ 0 & -D_1 & D_1 \end{vmatrix}. \quad (9)$$

From (1.2), (5) and (9) follows

$$\bar{R} = \begin{vmatrix} R & 0 & 0 \\ 0 & 0 & 0 \\ 0 & 0 & 0 \end{vmatrix} + \rho \begin{vmatrix} N_1 & -N_2^T & 0 \\ -N_2 & 2D_1 & -D_1 \\ 0 & -D_1 & (N_1 + D_1) \end{vmatrix}, \quad (10)$$

From figures and formulas (1.3), (3) follows

$$\bar{E} = -\rho \cdot \begin{array}{c} \left. \begin{array}{l} 0 \\ \dots \\ 0 \end{array} \right\} 2n \\ \left. \begin{array}{l} \\ \\ \\ \end{array} \right\} \end{array}, \quad (11)$$

So, as follows from (1.1) and (1.5), in the considered electric circuit the following function is being minimized

$$F(i) = \left\{ \begin{aligned} & \frac{R}{2} i_1^T i_1 + \rho \cdot h \cdot N_2^T i_3 + \\ & + \frac{\rho}{2} \cdot \left( i_1^T N_1^T i_1 - 2i_1^T N_2^T i_2 + 2i_2^T i_2 \right) \\ & \left( -2i_2^T i_3 + i_3^T N_1^T i_3 + i_3^T i_3 \right) \end{aligned} \right\}, \quad (12)$$

and the search for minimum of function (12) is performed as a descent along gradient

$$p = \left( \begin{aligned} & Ri_1 + \rho \cdot (N_1^T i_1 - N_2^T i_2) \\ & \rho \cdot (N_2^{TT} i_1 + 2D_1 i_2 - D_1 i_3) \\ & \rho \cdot (D_1 i_2 + (N_1^T + D_1) i_3 + N_2^{TT} h) \end{aligned} \right). \quad (13)$$

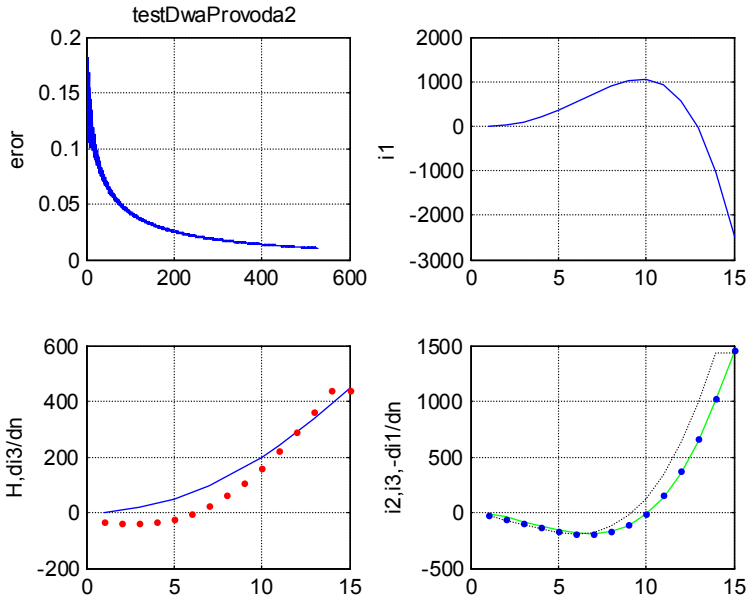

Fig. 1.

The optimal step size is determined from (1.6). The program calculates `testDwaProvoda2` two wire line with  $r = 1$ ,  $\rho = 500$ ,  $n = 15$  - see Fig. 1, where

- in the first window – computation error is shown
- in the second window – current function  $i_1(n)$ ,

- in the third window – function  $h(n)$  (dotted line) and function  $\frac{di_3(n)}{dn}$  (full line),
- in the fourth window – current  $i_2$  function (full line), current  $i_3$  function (dotted line), function  $\left(-\frac{di_1(n)}{dn}\right)$  (dash line).

As was mentioned, the sources of end currents  $i_{1,0}$ ,  $i_{1,n}$ ,  $i_{3,1}$ ,  $i_{3,n}$  may be placed at the edges of the electric lines. If some of this sources are absent, then the corresponding currents should be computed. If some of these sources are present, then the problem of finding the absolute minimum transforms into the problem of finding minimum under the constraints of the form  $i_g = \text{const}$ , where  $i_g \in \{i_{1,0}, i_{1,n}, i_{3,1}, i_{3,n}\}$ .

Let us denote by the symbols  $i_{1\Rightarrow}$ ,  $i_{1\Leftarrow}$  the vectors displaced along the line to the right and to the left accordingly with respect to vector  $i_1$ :

$$\text{if } i_1 = \begin{pmatrix} i_{1,1} \\ i_{1,2} \\ i_{1,3} \\ \dots \\ i_{1,n-1} \\ i_{1,n} \end{pmatrix}, \text{ then } i_{1\Rightarrow} = \begin{pmatrix} 0 \\ i_{1,2} \\ i_{1,3} \\ i_{1,4} \\ \dots \\ i_{1,n-1} \end{pmatrix}, \quad i_{1\Leftarrow} = \begin{pmatrix} i_{1,2} \\ i_{1,3} \\ i_{1,4} \\ \dots \\ i_{1,n-1} \\ 0 \end{pmatrix}.$$

Examining the matrices  $N_1$  and  $N_2$ , we can notice that

$$N_1 i_1 = (2i_1 - i_{1\Rightarrow} - i_{1\Leftarrow}), \tag{14}$$

$$N_2 i_1 = (i_1 - i_{1\Rightarrow}), \tag{15}$$

$$N_2^T i_1 = (i_1 - i_{1\Leftarrow}), \tag{16}$$

### 2.3. The Functional for Continuous Electric Line

Passing from the elements of discrete electric line again to the line length differentials we may consider the vector-function  $\vec{i}$  as a function of coordinate  $z$ , i.e.,  $i = i(z)$ . Then

$$(2i - i_{\rightarrow} - i_{\leftarrow}) = -\frac{\partial^2 i(z)}{\partial z^2},$$

$$(i - i_{\rightarrow}) = -\frac{\partial i(z)}{\partial z},$$

$$(i - i_{\leftarrow}) = \frac{\partial i(z)}{\partial z}$$

and, taking into account (2.14, 2.15, 2.16), we get

$$N_1 \cdot i_1 = -\frac{\partial^2 i_1(z)}{\partial z^2}, \quad (1)$$

$$N_2 \cdot i_2 = -\frac{\partial i_2(z)}{\partial z}, \quad (2)$$

$$N_2^T \cdot i_2 = \frac{\partial i_2(z)}{\partial z}, \quad (2a)$$

From (2.13) we get:

$$p = \begin{pmatrix} r i_1 + \rho \cdot \left( -\frac{\partial^2 i_1}{\partial z^2} + \frac{\partial i_2}{\partial z} \right) \\ \rho \cdot \left( -\frac{\partial i_1}{\partial z} + 2i_2 - i_3 \right) \\ \rho \cdot \left( -i_2 - \frac{\partial^2 i_3}{\partial z^2} + i_3 + \frac{\partial h}{\partial z} \right) \end{pmatrix}, \quad (3)$$

and (2.12) assumes the form:

$$F(i(z)) = \oint_z \left\{ \frac{r}{2} i_1^2 + \rho \cdot h \cdot \frac{\partial i_3}{\partial z} + \left( -i_1 \frac{\partial^2 i_1}{\partial z^2} + 2i_1 \frac{\partial i_2}{\partial z} + 2i_2^2 \right) + \frac{\rho}{2} \cdot \left( -2i_2 i_3 - i_3 \frac{\partial^2 i_3}{\partial z^2} + i_3^2 \right) \right\} dz, \quad (4)$$

Thus, (4) is a functional with respect to the function  $i = i(z)$ . By analogy with discrete line it follows that the computation of the considered continuous electric line consists in finding the minimum of

functional (4), which is performed by descent along the gradient (3). The optimal step size is determined according to (1.6) by the formula

$$a = \frac{\int_{z_0}^{z_1} (p^T p \cdot dz)}{\int_{z_0}^{z_1} (p^T \bar{R} \cdot p \cdot dz)} \quad (4a)$$

Notice that the expression

$$p(z) = 0, \quad (5)$$

where  $p(z)$  is determined according to (3), is an Euler equation for the functional (4). So, (5) is a minimum condition for functional (4), which follows as from the analogy with discrete line, as also from formulas rearrangement.

From physical considerations it is clear that

$$i_2 \approx i_3, \text{ if } \rho \rightarrow \infty, \quad (6)$$

Therefore, and from (3) and (5) it follows that in the neighborhood of minimum

$$\begin{vmatrix} ri_1 + \rho \cdot \left( -\frac{\partial^2 i_1}{\partial z^2} + \frac{\partial i_3}{\partial z} \right) \\ \rho \cdot \left( -\frac{\partial i_1}{\partial z} + i_3 \right) \\ \rho \cdot \left( -\frac{\partial^2 i_3}{\partial z^2} + \frac{\partial h}{\partial z} \right) \end{vmatrix} \approx 0, \quad (7)$$

or

$$ri_1 + \rho \cdot \left( -\frac{\partial^2 i_1}{\partial z^2} + \frac{\partial i_3}{\partial z} \right) \approx 0, \quad (8)$$

$$\frac{\partial i_1}{\partial z} + i_3 \approx 0, \quad (9)$$

$$-\frac{\partial^2 i_3}{\partial z^2} + \frac{\partial h}{\partial z} \approx 0. \quad (10)$$

From (10) and (9) we get:

$$\frac{\partial^2 i_3}{\partial z^2} \approx \frac{\partial h}{\partial z}, \quad \frac{\partial i_3}{\partial z} \approx h \quad (12)$$

or

$$\frac{\partial^2 i_1}{\partial z^2}(z) \approx h(z), \tag{13}$$

Thus, the computation of continuous line is equivalent to the solution of the equation (13).

Let us consider an operator built on the base of (2.10), (1), (2):

$$\mathfrak{R} = \begin{pmatrix} \left( r - \rho \frac{\partial^2}{\partial z^2} \right) & \left( \rho \frac{\partial}{\partial z} \right) & 0 \\ \left( \rho \frac{\partial}{\partial z} \right) & (2\rho) & (-\rho) \\ 0 & (-\rho) & \left( \rho - \rho \frac{\partial^2}{\partial z^2} \right) \end{pmatrix}, \tag{14}$$

Comparing (1.5), (2.13) and (3), we see that

$$p = \mathfrak{R}(i) + \begin{pmatrix} 0 \\ 0 \\ \rho \frac{\partial h}{\partial z} \end{pmatrix}, \tag{15}$$

and the functional (4) assumed the form:

$$F(i(z)) = \oint_z \left\{ \frac{1}{2} i^T \cdot \mathfrak{R}(i) + \rho \cdot h \cdot \frac{\partial i_3}{\partial z} \right\} dz, \tag{16}$$

see also (1.1). The optimal step size is determined according to (4a) by the formula

$$a = \frac{\oint_z (p^T p \cdot dz)}{\oint_z (p^T \mathfrak{R}(p) \cdot dz)} \tag{17}$$

As in discrete case, the sources of end currents  $i_1(z_0)$ ,  $i_1(z_n)$ ,  $i_3(z_0)$ ,  $i_3(z_n)$  may be placed at the edges of the electric line. If some of these sources are absent, then the corresponding currents should be computed. If some of these sources are present, then the problem of finding the absolute minimum turns into the problem of finding minimum under the constraints of the form  $i_g = \mathbf{const}$ , where

$i_g \in \{i_1(z_0), i_1(z_n), i_3(z_0), i_3(z_n)\}$ . According to (9) we may write

$$i_3(z_0) = \frac{\partial i_1}{\partial z}(z_0), \quad i_3(z_n) = \frac{\partial i_1}{\partial z}(z_n).$$

Thus, all the initial values of the currents may be expressed in terms of  $i_1(z_0), i_1(z_n), \frac{\partial i_1}{\partial z}(z_0), \frac{\partial i_1}{\partial z}(z_n)$ .

### 2.4. The Functional for Continuous Electric Volume

We shall call *electric volume* a three-dimensional space with coordinates  $x, y, z$ , where each point is an intersection of three orthogonal two-wire electric lines. Note that we have already considered electric plane in the context of a similar problem. The aim of analyzing the electric volume is that it (as will be shown further) is a visual and computational model of the Laplace and Poisson equations [14]. Let us denote :

$$\Delta'U = \frac{\partial U}{\partial x} + \frac{\partial U}{\partial y} + \frac{\partial U}{\partial z}, \quad \Delta U = \frac{\partial^2 U}{\partial x^2} + \frac{\partial^2 U}{\partial y^2} + \frac{\partial^2 U}{\partial z^2}.$$

By analogy with the previous consideration, it may be shown that for an electric volume

$$F(i) = \oint_z \left\{ \oint_y \left\{ \oint_x \left\{ \frac{1}{2} i^T \mathfrak{R}(i) + \rho \cdot h \cdot \Delta' i_3 \right\} dx \right\} dy \right\} dz. \quad (1)$$

$$\mathfrak{R} = \begin{vmatrix} (r - \rho\Delta) & (\rho\Delta') & 0 \\ (\rho\Delta') & (2\rho) & (-\rho) \\ 0 & (-\rho) & (\rho - \rho\Delta) \end{vmatrix}, \quad (2)$$

$$p = \mathfrak{R}(i) + \begin{vmatrix} 0 \\ 0 \\ \rho \cdot \Delta' h \end{vmatrix}. \quad (3)$$

Thus, the computation of the considered continuous electric volume consists in finding the minimum of functional (1), which is performed by descent along the gradient (5). The optimal step size is determined according to (3.17) by the formula

$$a = \frac{\int_z \left\{ \int_y \left\{ \int_x \left\{ p^T p \right\} dx \right\} dy \right\} dz}{\int_z \left\{ \int_y \left\{ \int_x \left\{ p^T \mathfrak{R}(p) \right\} dx \right\} dy \right\} dz} \quad (4)$$

By analogy with continuous electric line it may be shown that the computation of continuous electric volume is equivalent to the solution of equation

$$\Delta i_1(x, y, z) \approx h(x, y, z), \quad (5)$$

which is Poisson equation – see (1.3). Thus, the solution of Poisson equation is equivalent to finding global absolute minimum of the functional (1), and the stable value of the current function  $i_1(x, y, z)$  has the form of Poisson equation (5).

Just as for electric line, at the boundary of electric volume boundary current sources may be located  $i_1(x_g, y_g, z_g)$ ,  $i_3(x_g, y_g, z_g)$ , where  $(x_g, y_g, z_g)$  - coordinates of the boundary points. If some of these sources are absent, then the corresponding currents should be computed. If some of these sources are present, then the problem of finding the absolute minimum transforms into the problem of finding minimum under the constraints of the form  $i_g(\ ) = \text{const}$ , where  $i_g(\ ) = \{ i_1(x_g, y_g, z_g), i_3(x_g, y_g, z_g) \}$ . Ho  $i_3(\ ) = \Delta i_1(\ )$ . In this way all the boundary values of  $i_1(\ )$ ,  $\Delta i_1(\ )$ .

Let's note the following. The classical methods of Poisson equation solution require naming or the value of the sought function, or the value of a certain function depending on the three partial derivatives of the sought function in every boundary point – else the unique solution (so called Dirichlet and Neumann equations [22]) can not be found. In our case on points of border these conditions are defined by the specified currents  $i_1(\ )$ ,  $\Delta i_1(\ )$ .



## 2.5. The Functional for Non-Homogeneous Continuous Electric Volume

Above we had assumed that in every point of electric volume there is a source of current  $h$  so, that  $\Delta' i_3 = h$  or (disregarding the current in resistance  $\rho$ )

$$\frac{\partial i_3}{\partial x} + \frac{\partial i_3}{\partial y} + \frac{\partial i_3}{\partial z} = h. \quad (1)$$

Further we shall assume that in the electric volume for each  $k$ -point there are three corresponding current sources  $(\alpha_k \cdot h_k)$ ,  $(\beta_k \cdot h_k)$ ,  $(\gamma_k \cdot h_k)$ , where all the values are functions of coordinates. It is illustrated in the Fig. 3, where

$\alpha$ ,  $h$ ,  $\gamma$  - Dennis transformers with like transformation coefficients.

$d$  - Dennis transformer with a unit transformation coefficient

$i_{3x}$ ,  $i_{3y}$ ,  $i_{3z}$  - the secondary circuit current in the direction of coordinate  $x$ ,  $y$ ,  $z$  accordingly. (the secondary circuit in the direction of  $z$  is not shown on the Figure).

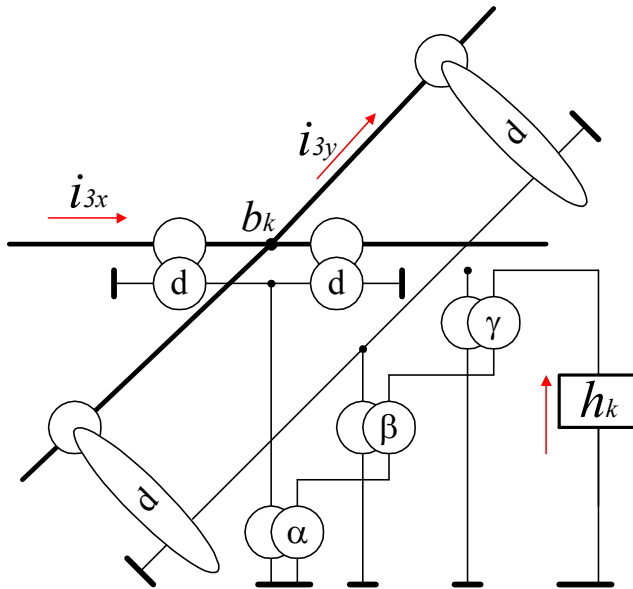

Fig. 3. Fragment of Non-Homogeneous Electric Volume.

With such connection of the current source through the transformers the following condition is fulfilled

$$\alpha \frac{\partial i_3}{\partial x} + \beta \frac{\partial i_3}{\partial y} + \gamma \frac{\partial i_3}{\partial z} = h. \quad (2)$$

It is easy to see that then the functional (4.1) takes the form

$$F(i) = \oint_z \left\{ \oint_y \left\{ \oint_x \left[ \frac{1}{2} i^T \mathfrak{R}(i) + \rho h \left( \alpha \frac{\partial i_3}{\partial x} + \beta \frac{\partial i_3}{\partial y} + \gamma \frac{\partial i_3}{\partial z} \right) \right] \right\} dx \right\} dy \Bigg| dz, \quad (3)$$

and the gradient (4.3) takes the form

$$p = \mathfrak{R}(i) + \begin{pmatrix} 0 \\ 0 \\ \rho \cdot \left( \alpha \frac{\partial h}{\partial x} + \beta \frac{\partial h}{\partial y} + \gamma \frac{\partial h}{\partial z} \right) \end{pmatrix}, \quad (4)$$

where the operator  $\mathfrak{R}$  is determined according to (4.2).

By analogy with the previous discussion we may show that the computation of a continuous electric volume with triple current sources is equivalent to the solution of equation

$$\left( \alpha_x \frac{\partial^2 i_1}{\partial x^2} + \beta_y \frac{\partial^2 i_1}{\partial y^2} + \gamma_z \frac{\partial^2 i_1}{\partial z^2} \right) \approx h(x, y, z), \quad (5)$$

which is the Poisson equation for *non-homogeneous medium* (1.4). Thus, the solution of equation (5) is equivalent to seeking the global absolute minimum of the functional (2), and the stable value of the current function  $i_1(x, y, z)$  has the form of this equation.

## 3. Partial Differential Equations

### 3.1. Classical Partial Differential Equations

The above cited electrical models illustrate the fact that the partial differential equations may be considered as the necessary extremum conditions of certain functionals. Further we shall view various functional and Ostrogradski equations [16], which must be satisfied by the function realizing the extremum of those functionals. Further we shall denote:

$$\Delta i = \frac{\partial^2 i}{\partial x^2} + \frac{\partial^2 i}{\partial y^2} + \frac{\partial^2 i}{\partial z^2},$$

$$\Delta_{\alpha\beta\gamma}i = \alpha(x, y, z)\frac{\partial^2 i}{\partial x^2} + \beta(x, y, z)\frac{\partial^2 i}{\partial y^2} + \gamma(x, y, z)\frac{\partial^2 i}{\partial z^2}.$$

For the functional

$$F(i) = \int_z \left\{ \int_y \left\{ \int_x \left[ \frac{1}{2} i \cdot \Delta i + h(x, y, z) \cdot i \right] dx \right\} dy \right\} dz$$

the Poisson equation for homogeneous medium comprises the extremum condition

$$\Delta i(x, y, z) = h(x, y, z).$$

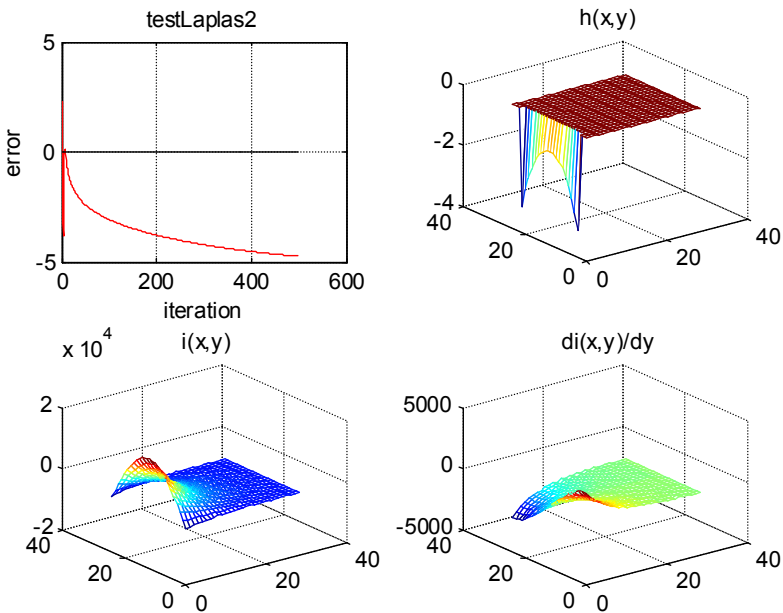

Fig. 4. For example 8.

**Example 8.** Let us consider a plane problem of the form

$$\Delta i(x, y) = h(x, y),$$

where

$$h(x, y) = \begin{cases} a \cdot \text{ch}(\beta y), & \text{if } x = 0, \quad y = (-s, s), \\ 0, & \text{if } x > 0, \end{cases}$$

and  $a, \beta, s$  - are certain constants. Fig. 4 shows the results of this problem's solution by the proposed method – the relative error *error* depending on the iterations number, function  $h(x, y)$ , function  $i(x, y)$ , function  $\frac{\partial}{\partial y} i(x, y)$ .

For the functional

$$F(i) = \int_z \left\{ \int_y \left\{ \int_x \left\{ \frac{1}{2} i \cdot \Delta_{\alpha\beta\gamma} i + h(x, y, z) \cdot i \right\} dx \right\} dy \right\} dz$$

the Poisson equation for non-homogeneous medium comprises the **extremum** condition

$$\Delta_{\alpha\beta\gamma} i(x, y, z) = h(x, y, z)$$

Let us consider another functional

$$F(i) = \int_z \left\{ \int_y \left\{ \int_x \left\{ (\Delta' i)^2 + k \cdot i^2 \right\} dx \right\} dy \right\} dz$$

For it the condition of extremum is the Helmgoltz equation

$$\Delta i(x, y, z) = k \cdot i.$$

In the general case we may consider the following functional

$$F(i) = \int_z \left\{ \int_y \left\{ \int_x \left\{ \frac{1}{2} i \cdot \Delta i + h(x, y, z) \cdot i + \frac{1}{2} k^2 \cdot i^2 \right\} dx \right\} dy \right\} dz$$

for which the condition of extremum is the equation

$$\Delta i(x, y, z) + k^2 \cdot i(x, y, z) + h(x, y, z) = 0.$$

**Example 9.** Let us consider a plane problem of the form

$$\Delta i(x, y) + r \cdot i(x, y) = h(x, y),$$

where

$$h(x, y) = \begin{cases} a \cdot \text{ch}(\beta y), & \text{if } x = 0, \quad y = (-s, s), \\ 0, & \text{if } x > 0, \end{cases}$$

and  $a, \beta, s$  - are certain constants. Fig. 4 shows the results of this problem's solution by the proposed method – the relative error *error* depending on the iterations number,

function  $h(x, y)$ , function  $i(x, y)$ , function  $\frac{\partial}{\partial y} i(x, y)$ .

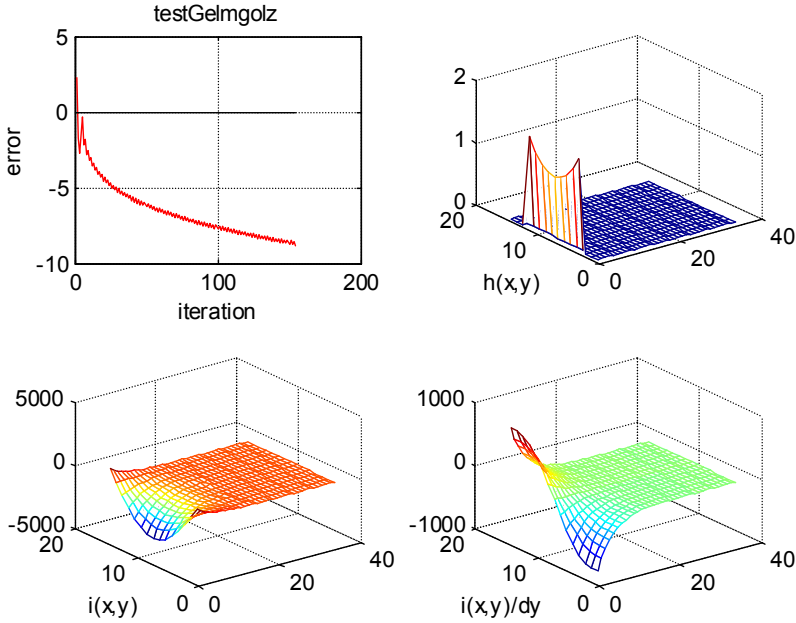

Fig. 5. For example 9.

In the general case we may consider the

$$F(i) = \int_z \left\{ \int_y \left\{ \int_x \left[ \frac{1}{2} i \cdot \Delta_{\alpha\beta\gamma} i + h(x, y, z) \cdot i + \frac{1}{2} k \cdot i^2 \right] dx \right\} dy \right\} dz, \quad (1)$$

the condition of extremum for it is the equation

$$\Delta_{\alpha\beta\gamma} i(x, y, z) = h(x, y, z) + k \cdot i. \quad (2)$$

To find the solution of equation (2) we may apply the method of finding the minimum of functional (1), which (as it follows from the above cited) consists of iteration process, where on each iteration the gradient is being computed

$$p = \Delta_{\alpha\beta\gamma} i(x, y, z) - h(x, y, z) - k \cdot i. \quad (3)$$

and the step of the variable

$$a = \frac{\oint_z \left\{ \oint_y \left\{ \oint_x p^T p dx \right\} dy \right\} dz}{\oint_z \left\{ \oint_y \left\{ \oint_x \left\{ p \cdot \Delta_{\alpha\beta\gamma} p - k \cdot p^2 \right\} dx \right\} dy \right\} dz}. \quad (4)$$

This formula is obtained by analogy with (1.13b).

The further complication lies in the fact that the variable is considered as a function of time  $i(t)$ . So we can consider a functional

$$F(i) = \oint_z \left\{ \oint_y \left\{ \oint_x \left[ \frac{1}{2} i \cdot \Delta_{\alpha\beta\gamma} i + h(x, y, z) \cdot i + \frac{1}{2} k \cdot i^2 + \frac{1}{2} c \cdot \left( \frac{\partial i}{\partial t} \right)^2 \right] dx \right\} dy \right\} dz, \quad (5)$$

the extremum condition for which is presented by the equation

$$\Delta_{\alpha\beta\gamma} i = h(x, y, z, t) + k \cdot i + c \left( \frac{\partial^2 i}{\partial t^2} \right). \quad (6)$$

In this case the gradient is

$$p = \Delta_{\alpha\beta\gamma} i - h(x, y, z, t) - k \cdot i - c \left( \frac{\partial^2 i}{\partial t^2} \right) \quad (7)$$

and the step by the variable

$$a = \frac{\oint_z \left\{ \oint_y \left\{ \oint_x p^T p dx \right\} dy \right\} dz}{\oint_z \left\{ \oint_y \left\{ \oint_x \left[ p \cdot \Delta_{\alpha\beta\gamma} p - k \cdot p^2 + c \cdot \left( \frac{\partial p}{\partial t} \right)^2 \right] dx \right\} dy \right\} dz}. \quad (8)$$

This formula is also obtained by analogy with (1.13b).

The realization of the search for the minimum for functionals (1) and (5) depends on the form of functions  $h(x, y, z, t)$  in the same way as in the case of functionals discussed in the Chapters 5 and 7.

### 3. 2. Special Partial Differential Equations

Finally we shall discuss the method of solving the equation

$$\Delta_{\alpha\beta\gamma}i(x, y, z) = h(x, y, z) + k \cdot i + c \left( \frac{\partial^2 i}{\partial t^2} \right) + m \left( \frac{\partial i}{\partial t} \right).$$

which differs from (8.3.6) by the presence of last term. **There doesn't exist** a functional for which this equation is the condition of extremum.

For its solution we shall use the above stated extremum principle.

After changing the notations

$$\Delta_{\alpha\beta\gamma}q + Sq + Mq'' + Rq' - E = 0, \tag{1}$$

where

$S, M, R$  are constant coefficients,

$q, E$  are functions of coordinates  $x, y, z$  and time  $t$ .

Further we shall use the line of reasoning by analogy with section 4.

Now we shall consider *the functional*

$$F(q) = \int_0^T \left\{ \begin{array}{l} \frac{1}{2} q (\Delta_{\alpha\beta\gamma} q) + q^T S q - \\ - q'^T M q' + q^T R q' - \frac{1}{2} E q \end{array} \right\} dt, \tag{2}$$

“gradient”

$$p = \Delta_{\alpha\beta\gamma} q + Sq + Mq'' + Rq' - E, \tag{3}$$

*the direction* of moving

$$\overline{\delta q'} = \frac{2\mu \cdot (A'_1 + A'_2)}{B_1 + \mu \cdot B_2} \overline{p}, \tag{4}$$

where

$$A'_1 = \int_0^T \int_{x,y,z} \left[ \left( -q (\Delta_{\alpha\beta\gamma} p) - Sqp - Mq'p' + \right) + \frac{Ep}{2} \right] dx dy dz dt, \tag{5}$$

$$B_1 = 2 \int_0^T \int_{x,y,z} \left( p (\Delta_{\alpha\beta\gamma} p) + Sp^2 + Mp'^2 \right) dx dy dz dt, \tag{6}$$

$$A_2 = \int_0^T \int_{x,y,z} \left[ \begin{array}{c} \frac{1}{2} \left( p(\Delta_{\alpha\beta\gamma} q) + Spq + Mpq'' \right) \\ - \hat{p}(\Delta_{\alpha\beta\gamma} q') - S\hat{p}q' - Mp'q' \\ - Rpq' \\ + Ep/2 \end{array} \right] dx dy dz dt, \quad (7)$$

$$B_1 = 2 \int_0^T \int_{x,y,z} (Rp^2) dx dy dz dt. \quad (8)$$

By analogy with Theorem 4.1 we may assert that

the movement in functional (2) in the direction (4) is equivalent to moving to global saddle points of the two secondary functionals, similar to functionals (13) and (14), and the stationary value equation is (1).

Here it should be noted that the realization of the functional (2) minimization method depends on the form of functions  $E(x, y, z, t)$  as for the cases of functionals treated in the chapters 5 and 7.

Another method consists in building electrical models of the form of partial differential equations and in the corresponding electrical circuits computation. This method was covered above.



# Chapter 9. The Functional for Maxwell Equations

---

## 1. Maxwell Equations as a Corollary of Variational Principle

### 1.1. Introduction

It is known [27], that Maxwell equations are deduced from the least action principle. For this purpose it is necessary to introduce the concept of vector magnetic potential and formulate a certain functional with respect to such potential and to scalar electrical potential, and this functional will be called action. Then by varying the action with respect to vector magnetic potential and to scalar electrical potential the conditions of this functional's minimum may be found. Further (after certain reductions) it is shown that this condition (with regard to the potentials) is equivalent to equations system with respect to electric and magnetic intensities. The obtained equation system corresponds **only to four** of Maxwell equations. It is evident, since the vector magnetic potential and electric scalar potential provide only four varying functions. But such partial result permits authors to conclude that **all** Maxwell equations (with respect to the intensities) are the consequences of least action principle as the above determined functional

But all Maxwell equations do not follow from this functional!

Furthermore, the Maxwell equations are dealing with currents in a medium with a certain electroconductivity. As a consequence, there are heat losses, i.e. energy dissipation. It means that, for the sake of the least action principle in addition to electromagnetic energy, the thermal energy should be also included in the functional; but this energy is not a part of Lagrangian. Therefore the Lagrange formalism is in principle not applicable to Maxwell equations.

Thus, the above conclusion, which has some cognitive value, does not demonstrate a triumph of the least action principle. And, all the more, this functional cannot be used for direct solution of technical

problems (using the above described method of descent along the functional) So it turns out that the Lagrange formalism is insufficient for the deduction of Maxwell equations.

The matter becomes complicated also because for symmetrical form of Maxwell equations (figuring magnetic and electrical charges), an electromagnetic field cannot be described by vector potential that is continuous in all the space Therefore the symmetrical Maxwell equations cannot be deducted from variational least action principle, where the action is an integral of difference between kinetic and potential energies.

In this section we present such a functional with respect to intensities, whose first variations with respect to intensities when they become zero, coincide with Maxwell equations with respect to intensities. Then we shall describe the descent method along these variations, which is equivalent to Maxwell equations solution.

Further we shall be dealing with three-dimensional vectors in a vector space with the axes  $0x$ ,  $0y$ ,  $0z$  and the orts of these axes  $i, j, k$  correspondingly. Usually a vector  $H$  will be denoted as  $H = (H_x, H_y, H_z)$ , with its coordinates in the brackets. AS it is known[14], vector-rotor of the vector  $H$ , scalar divergence of the vector  $H$ , vector-gradient of the function  $a(x, y, z)$  have accordingly the following form

$$\text{rot}(H) = \left( \left( \frac{\partial H_z}{\partial y} - \frac{\partial H_y}{\partial z} \right), \left( \frac{\partial H_x}{\partial z} - \frac{\partial H_z}{\partial x} \right), \left( \frac{\partial H_y}{\partial x} - \frac{\partial H_x}{\partial y} \right) \right),$$

$$\text{div}(H) = \left( \frac{\partial H_x}{\partial x} + \frac{\partial H_y}{\partial y} + \frac{\partial H_z}{\partial z} \right),$$

$$\text{grad}(a) = \left[ \frac{\partial a}{\partial x}, \frac{\partial a}{\partial y}, \frac{\partial a}{\partial z} \right].$$

Let us consider a functional [26]

$$\Phi_o = \int_z \left\{ \int_y \left\{ \int_x \left[ \begin{aligned} &H_x \frac{\partial E_z}{\partial y} - H_x \frac{\partial E_y}{\partial z} + \\ &+ H_y \frac{\partial E_x}{\partial z} - H_y \frac{\partial E_z}{\partial x} + \\ &+ H_z \frac{\partial E_y}{\partial x} + H_z \frac{\partial E_x}{\partial y} + \\ &- E_x \frac{\partial H_z}{\partial y} + E_x \frac{\partial H_y}{\partial z} + \\ &- E_y \frac{\partial H_x}{\partial z} + E_y \frac{\partial H_z}{\partial x} + \\ &- E_z \frac{\partial H_y}{\partial x} + E_z \frac{\partial H_x}{\partial y} + \end{aligned} \right] dx \right\} dy \right\} dz, \quad (1)$$

with respect to the functions  $H_x, H_y, H_z, E_x, E_y, E_z$  of three variables  $x, y, z$ .

The necessary conditions of extremum for a function from several independent variables are Ostrogradsky equations [16] which for every function have the form:

$$\frac{\partial f}{\partial v} - \sum_{a=x,y,z,t} \left[ \frac{\partial}{\partial a} \left( \frac{\partial f}{\partial (dv/da)} \right) \right] = 0, \quad (1a)$$

where  $f$  is an integration element,  $v(x, y, z, t)$  is a variable function, and  $a$  – independent variable. For this functional they are as follows:

- with respect to variable  $H_x$  (see the terms 1, 2, 9, 12):

$$2 \frac{\partial E_z}{\partial y} - 2 \frac{\partial E_y}{\partial z} = 0,$$

- with respect to variable  $H_y$  (see the terms 3, 4, 8, 11):

$$2 \frac{\partial E_x}{\partial z} - 2 \frac{\partial E_z}{\partial x} = 0,$$

- with respect to variable  $H_z$  (see the terms 5, 6, 7, 10):

$$2 \frac{\partial E_y}{\partial x} - 2 \frac{\partial E_x}{\partial y} = 0,$$

- with respect to variable  $E_x$  (see the terms 3, 6, 7, 8):

$$2 \frac{\partial E_z}{\partial y} - 2 \frac{\partial E_y}{\partial z} = 0,$$

- with respect to variable  $E_y$  (see the terms 2, 5, 9, 10):

$$2 \frac{\partial E_z}{\partial y} - 2 \frac{\partial E_y}{\partial z} = 0,$$

- with respect to variable  $E_z$  (see the terms 1, 4, 11, 12):

$$2 \frac{\partial H_y}{\partial x} - 2 \frac{\partial H_x}{\partial y} = 0.$$

Hence it follows that the necessary conditions of the extremum of functional (1) are the equations

- with respect to variable  $E$ :

$$2 \cdot \text{rot}H = 0, \tag{2}$$

- with respect to variable  $H$ :

$$2 \cdot \text{rot}E = 0. \tag{3}$$

For the sake of convenience we shall further denote the integrand in (1) by  $\mathfrak{Z}(H, E)$ . Then the functional (1) will be as follows:

$$\Phi_o = \int_z \left\{ \int_y \left\{ \int_x \left\{ \mathfrak{Z}(H, E) \right\} dx \right\} dy \right\} dz, \tag{6}$$

It is easy to see that

$$\mathfrak{Z}(H, E) = H \cdot \text{rot}(E) - E \cdot \text{rot}(H). \tag{7}$$

Here each cofactor is considered as a three-component vector in the sense of matrix algebra. Thus the following Lemma holds true:

**Lemma 1.** The necessary conditions of the extremum of functional (6, 7) are the equations (2, 3).

## 1.2. Constructing a functional for the Maxwell Equations

We shall further use the same line of reasoning as in deducing the variational principle for an electric circuit – see section 1.4. Consider a functional

$$\Phi = \int_0^T \left\{ \int_z \left\{ \int_y \left\{ \int_x \left[ \begin{aligned} & \frac{1}{2} \mathfrak{J}(H', E') - \frac{1}{2} \mathfrak{J}(H'', E'') + \\ & + \frac{\mu}{2} \left( H' \frac{dH''}{dt} - H'' \frac{dH'}{dt} \right) - \\ & - \frac{\varepsilon}{2} \left( E' \frac{dE''}{dt} - E'' \frac{dE'}{dt} \right) - \\ & - K' \left( \operatorname{div} E' - \frac{\rho}{2\varepsilon} \right) + \\ & + K'' \left( \operatorname{div} E'' - \frac{\rho}{2\varepsilon} \right) + \\ & + L' \left( \operatorname{div} H' - \frac{\sigma}{2\mu} \right) - \\ & - L'' \left( \operatorname{div} H'' - \frac{\sigma}{2\mu} \right) \end{aligned} \right. \right\} dx \right\} dy \right\} dz \right\} dt \quad (1)$$

Here

- $t$  – time,
- $H', H'', E', E'', K', K'', L', L''$  - variable vector - functions of coordinates  $x, y, z$ .

In this case the above mentioned Ostrogradsky equations (1.1.1a) taking into account Lemma 1 will take the following form:

- with respect to variable  $E'$  :

$$\operatorname{rot} H' - \varepsilon \frac{dE''}{dt} - \operatorname{grad}(K') = 0, \quad (2)$$

- with respect to variable  $E''$  :

$$-\operatorname{rot}H'' + \varepsilon \frac{dE'}{dt} + \operatorname{grad}(K'') = 0, \quad (3)$$

- with respect to variable  $H'$ :

$$\operatorname{rot}E' + \mu \frac{dH''}{dt} + \operatorname{grad}(L') = 0, \quad (4)$$

- with respect to variable  $H''$ :

$$-\operatorname{rot}E'' - \mu \frac{dH'}{dt} - \operatorname{grad}(L'') = 0, \quad (5)$$

- with respect to variable  $K', L', K'', L''$  accordingly:

$$-\left(\operatorname{div}E' - \frac{\rho}{2\varepsilon}\right) = 0, \quad \left(\operatorname{div}H' - \frac{\sigma}{2\mu}\right) = 0, \quad (6a)$$

$$\left(\operatorname{div}E'' - \frac{\rho}{2\varepsilon}\right) = 0, \quad -\left(\operatorname{div}H'' - \frac{\sigma}{2\mu}\right) = 0. \quad (6b)$$

Owing to the symmetry of equations (2-5) we have:

$$E' = E'', \quad H' = H'', \quad K' = K'', \quad L' = L''. \quad (7)$$

Denote:

$$\begin{aligned} E &= E' + E'', & H &= H' + H'', \\ K &= K' + K'', & L &= L' + L''. \end{aligned} \quad (8)$$

Subtracting equation (3) from (2), we get

$$\operatorname{rot}H - \varepsilon \frac{dE}{dt} - \operatorname{grad}(K) = 0, \quad (9)$$

Similarly, from (4, 5) we get

$$\operatorname{rot}E + \mu \frac{dH}{dt} + \operatorname{grad}(L) = 0, \quad (10)$$

Similarly, from (6) we get

$$(\operatorname{div}E - \rho/\varepsilon) = 0, \quad (11)$$

$$(\operatorname{div}H - \sigma/\mu) = 0. \quad (12)$$

Equations (2) and (3) are necessary condition of the existence of functional (1) extremum with respect to the function  $E'$  and to the function  $E''$ . These extremum are of opposite character (minimum-maximum or maximum-minimum), as the equations (2) and (3) differ in

the terms signs. Consequently, these equations are necessary conditions of a saddle line existence with respect to the functions  $E'$  and  $E''$  in the functional (1).

Similarly, equations (4) and (5) are necessary conditions of the existence of a saddle line with respect to the functions  $H'$  and  $H''$  in the functional (1).

Similarly, equations (6) are necessary conditions of the existence of a saddle line with respect to the functions  $K'$ ,  $K''$  and a saddle point with respect to the functions  $L'$ ,  $L''$  in the functional (1).

The question of sufficient conditions of saddle points existence is still an open question (it will be discussed below). Should these conditions be found, it will mean that the following Statement holds true.

**Statement 1.** The functional (1) has an optimal saddle line in which the conditions (7) are fulfilled, and it is optimized on such functions  $E', E'', H', H'', K', K'', L', L''$ , which in sum (8) satisfy the equations (9-12).

It is easy to see that the equations (9-12) are symmetrical Maxwell equations, where

- $E$  - electric field intensity,
- $H$  - magnetic field intensity,
- $\mu$  - magnetic permeability,
- $\varepsilon$  - dielectric permittivity,
- $\rho$  - electric charge density
- $\sigma$  - hypothetic magnetic charge density,
- $\text{grad}(K)$  - electric current density,
- $\text{grad}(L)$  - hypothetic magnetic current density

Denote:

$$\mathbf{j} = \text{grad}(K), \tag{13}$$

$$\mathbf{m} = \text{grad}(L). \tag{14}$$

Consider the physical meaning of quantities  $K$ . Denote:

- $\varphi$  - electric scalar potential,
- $\mathcal{G}$  - electrical conductivity,
- $j_x$  - projection of the vector current density  $\mathbf{j}$  on axis  $ox$ .

Then we get  $j_x = -\mathcal{G} \frac{d\varphi}{dx}$ . But from (13) follows that  $j_x = \frac{dK}{dx}$ .

Consequently,

$$\frac{dK}{dx} = -\mathcal{G} \frac{d\phi}{dx}, \tag{15}$$

i.e.

$$K = -\mathcal{G}\phi. \tag{16}$$

Similarly,

$$\frac{dL}{dx} = -\zeta \frac{d\phi}{dx}, \tag{17}$$

$$L = -\zeta\phi, \tag{18}$$

where

- $\phi$  - magnetic scalar potential,
- $\zeta$  - magnetic conductivity.

### 1.3. About Sufficient Extremum Conditions

Further we shall consider along with vectors in the sense of vector algebra - vectors in the sense of matrix algebra. It will be clear from the context, which of the vectors we have in view. For the future we must note that the concept of derivative by a vector, may be found, for instance in B [14]. So, the functional (2.1) may be written in the form

$$\Phi = \int_0^T \left\{ \oint_z \left\{ \oint_y \left\{ \oint_x f(Z', Z'') dx \right\} dy \right\} dz \right\} dt, \tag{1}$$

where

- $Z'(X) = [E', H', K', L']$ ,  $Z''(X) = [E'', H'', K'', L'']$  - the functions vectors,
- $X = (x, y, z, t)$  - independent variables vector.

In this section we shall vary only the functions  $Z'(X) = [E', H', K', L']$ . The equations (2.2, 2.4, 2.6a) may be written as

$$p = 0, \tag{2}$$

where

$$p = \begin{vmatrix} pE \\ pH \\ pK \\ pL \end{vmatrix}, \tag{3}$$



$$p_E = \text{rot}H' - \varepsilon \frac{dE''}{dt} - \text{grad}(K'), \quad (4)$$

$$p_H = \text{rot}E' + \mu \frac{dH''}{dt} + \text{grad}(L'), \quad (5)$$

$$p_K = -\text{div}E' + \rho/2 \quad (6)$$

$$p_L = \text{div}H' - \sigma/2. \quad (7)$$

Vector  $p$  is a variation of functional  $\Phi$  with respect to function  $Z'$  and it depends on the function  $Z'$ , i. e.  $p = p(Z')$ . Remember that the function  $Z''$  here is fixed.

Now our reasoning will be in accordance to [7]. Let  $S$  be an extremal, satisfying the Statement 1, and, consequently, the gradient in it is  $p = p_S = 0$ . To find out the character of this extremum we must study the sign of the functional increment

$$\Delta\Phi = \Phi(S) - \Phi(C), \quad (8)$$

where  $C$  is the comparison line, where  $p = p_C \neq 0$ . Let

$$\Delta\Phi = \left\{ \begin{array}{l} A_1 \cdot p + A_2 \frac{\partial p}{\partial X} + B_1 \cdot p^2 + \\ + B_2 \left( \frac{\partial p}{\partial X} \right)^2 + B_3 \cdot p \cdot \frac{\partial p}{\partial X} \end{array} \right\}, \quad (9)$$

where  $A_1, A_2, B_1, B_2, B_3$  are known functions of  $Z'$  with fixed  $Z''$ . Then the following Statement 2 holds true

Let the values of vector  $Z$  on the lines  $S$  and  $C$  differ by

$$Z'_C - Z'_S = Z' - Z'_S = \Delta Z = a \cdot p, \quad (13)$$

where

$p$  is a variation on the line  $C$ ,

$a$  – a known number.

Let us denote:

$$q = \frac{dp}{dX}, \quad Q = \frac{dZ'}{dX}. \quad (14)$$

Then

$$\begin{aligned} \frac{\partial \Delta \Phi}{\partial a} &= \frac{\partial \Phi(\cdot)}{\partial a} = \int_X \frac{f(\cdot)}{\partial a} dX = \\ &= \int_X \left[ \frac{\partial f(\cdot)}{\partial Z'} \cdot \frac{\partial Z'}{\partial a} + \frac{\partial f(\cdot)}{\partial Q} \cdot \frac{\partial Q}{\partial a} \right] dX = \end{aligned} \quad (15)$$

$$= \int_X \left[ p \frac{\partial f(\cdot)}{\partial Z'} + q \cdot \frac{\partial f(\cdot)}{\partial Q} \right] dX;$$

$$\begin{aligned} \frac{\partial^2 \Delta \Phi}{\partial a^2} &= \frac{\partial}{\partial a} \int_X \left[ p \frac{\partial f(\cdot)}{\partial Z'} + q \cdot \frac{\partial f(\cdot)}{\partial Q} \right] dX = \\ &= \int_X \left[ p \frac{\partial^2 f(\cdot)}{\partial Z'^2} \cdot \frac{\partial Z'}{\partial a} + q \cdot \frac{\partial^2 f(\cdot)}{\partial Q^2} \cdot \frac{\partial Q}{\partial a} + \right. \\ &\quad \left. p \cdot \frac{\partial^2 f(\cdot)}{\partial Z' \partial Q} \cdot \frac{\partial Q}{\partial a} + q \cdot \frac{\partial^2 f(\cdot)}{\partial Z' \partial Q} \cdot \frac{\partial Z'}{\partial a} \right] dX = \quad (16) \\ &= \int_X \left[ p^2 \frac{\partial^2 f(\cdot)}{\partial Z'^2} + q^2 \cdot \frac{\partial^2 f(\cdot)}{\partial Q^2} + 2pq \cdot \frac{\partial^2 f(\cdot)}{\partial Z' \partial Q} \right] dX. \end{aligned}$$

For small  $a$  we may write

$$\Delta \Phi = a \frac{\partial \Delta \Phi}{\partial a} + a^2 \frac{\partial^2 \Delta \Phi}{\partial a^2}. \quad (17)$$

Then the following Statement 3 holds true:

**Statement 2.** If  $\frac{\partial^2 \Delta \Phi}{\partial a^2}$  is always non-negative (non-positive), then

the line brings a global strong minimum (maximum) to the functional.

Comparing (9, 15, 16, 17) we find that

$$\frac{\partial^2 \Delta \Phi}{\partial a^2} = \int_X \left[ p^2 \frac{\partial^2 f(\cdot)}{\partial Z'^2} + q^2 \cdot \frac{\partial^2 f(\cdot)}{\partial Q^2} + 2pq \cdot \frac{\partial^2 f(\cdot)}{\partial Z' \partial Q} \right] dX. \quad (18)$$

Thus, to find the sufficient conditions of the functional extremum existence, we must compute the second derivatives in the expression (18).

### 1.4. First Partial Derivatives

Let us find first the partial derivatives of the integrand function  $f(\cdot)$  in the functional (2.1) with respect to the functions with one stroke. To do this we must previously find the vectors

$$\frac{\partial \text{rot}(E)}{\partial E_x} = \frac{\partial \text{rot}(E)}{\partial E_y} = \frac{\partial \text{rot}(E)}{\partial E_z} = 0, \quad (1)$$

$$\begin{aligned} \partial \text{rot}(E) / \partial (\partial E_x / \partial y) &= (0, 0, -1), \\ \partial \text{rot}(E) / \partial (\partial E_x / \partial z) &= (0, 1, 0), \\ \partial \text{rot}(E) / \partial (\partial E_y / \partial x) &= (0, 0, 1) \\ \partial \text{rot}(E) / \partial (\partial E_y / \partial z) &= (-1, 0, 0), \\ \partial \text{rot}(E) / \partial (\partial E_z / \partial x) &= (0, -1, 0), \\ \partial \text{rot}(E) / \partial (\partial E_z / \partial y) &= (1, 0, 0) \end{aligned} \quad \Bigg| \quad (2)$$

and scalars

$$\frac{\partial \text{div}(E)}{\partial E_x} = \frac{\partial \text{div}(E)}{\partial E_y} = \frac{\partial \text{div}(E)}{\partial E_z} = 0, \quad (3)$$

$$\frac{\partial \text{div}(E)}{\partial (\partial E_x / \partial x)} = \frac{\partial \text{div}(E)}{\partial (\partial E_y / \partial y)} = \frac{\partial \text{div}(E)}{\partial (\partial E_z / \partial z)} = 1. \quad (4)$$

Let us consider vector  $X_1 = (x, y, z)$ . Then

$$\frac{\partial \text{div}(E)}{\partial (\partial E / \partial X_1)} = (1, 1, 1); \quad (5)$$

First we shall find the first partial derivatives of the integrand function  $f(\cdot)$  with respect to vector  $Z' = (E', H', K', L')$ . We have:

$$\begin{aligned} \frac{\partial f(\cdot)}{\partial(E'_x)} &= \frac{\partial}{\partial(E'_x)} \left( \frac{1}{2} \Re(H', E') - \frac{\varepsilon}{2} \left( E' \frac{\partial E''}{\partial t} - E'' \frac{\partial E'}{\partial t} \right) \right) = \\ &= \frac{\partial}{\partial(E'_x)} \left( -K' \left( \operatorname{div} E' - \frac{\rho}{2} \right) \right) = \\ &= \frac{\partial}{\partial(E'_x)} \left( \frac{1}{2} H' \cdot \operatorname{rot}(E') + \frac{1}{2} E' \cdot \operatorname{rot}(H') \right) = \\ &= \frac{\partial}{\partial(E'_x)} \left( -\frac{\varepsilon}{2} \left( E' \frac{\partial E''}{\partial t} - E'' \frac{\partial E'}{\partial t} \right) - K' \left( \operatorname{div} E' - \frac{\rho}{2} \right) \right) = \\ &= \frac{\partial}{\partial(E'_x)} \left( \frac{1}{2} E' \cdot \operatorname{rot}_x(H') - \frac{\varepsilon}{2} E' \frac{\partial E''}{\partial t} \right). \end{aligned}$$

Thus,

$$\frac{\partial f(\cdot)}{\partial(E'_x)} = \frac{1}{2} \left( \frac{\partial H'_z}{\partial y} - \frac{\partial H'_y}{\partial z} - \varepsilon \frac{\partial E''_x}{\partial t} \right). \quad (6)$$

Table 1 is filled in the same way.

Table 1.

|   | $\frac{\partial f(\cdot)}{\partial(E'_i)}$  | $\frac{\partial f(\cdot)}{\partial(H'_i)}$  |
|---|---|---|
| X | $\frac{\partial f(\cdot)}{\partial(E'_x)} = \frac{1}{2} \left( \frac{\partial H'_z}{\partial y} - \frac{\partial H'_y}{\partial z} - \varepsilon \frac{\partial E''_x}{\partial t} \right)$ | $\frac{\partial f(\cdot)}{\partial(H'_x)} = \frac{1}{2} \left( \frac{\partial E'_z}{\partial y} - \frac{\partial E'_y}{\partial z} + \mu \frac{\partial H''_x}{\partial t} \right)$ |
| Y | $\frac{\partial f(\cdot)}{\partial(E'_y)} = \frac{1}{2} \left( \frac{\partial H'_x}{\partial z} - \frac{\partial H'_z}{\partial x} - \varepsilon \frac{\partial E''_y}{\partial t} \right)$ | $\frac{\partial f(\cdot)}{\partial(H'_y)} = \frac{1}{2} \left( \frac{\partial E'_x}{\partial z} - \frac{\partial E'_z}{\partial x} + \mu \frac{\partial H''_y}{\partial t} \right)$ |
| Z | $\frac{\partial f(\cdot)}{\partial(E'_z)} = \frac{1}{2} \left( \frac{\partial H'_y}{\partial x} - \frac{\partial H'_x}{\partial y} - \varepsilon \frac{\partial E''_z}{\partial t} \right)$ | $\frac{\partial f(\cdot)}{\partial(H'_z)} = \frac{1}{2} \left( \frac{\partial E'_y}{\partial x} - \frac{\partial E'_x}{\partial y} + \mu \frac{\partial H''_z}{\partial t} \right)$ |

Keeping in mind the definition of rotor from this table we find

$$\frac{\partial f(\cdot)}{\partial(E')} = \left( \operatorname{rot}(H') - \frac{\varepsilon}{2} \cdot \frac{dE''}{dt} \right), \quad (6a)$$

$$\frac{\partial f(\cdot)}{\partial(H')} = \left( \operatorname{rot}(E') + \frac{\mu}{2} \cdot \frac{dH''}{dt} \right). \quad (6b)$$

We have also:

$$\frac{\partial f(\cdot)}{\partial(K')} = -\operatorname{div}E' + \rho/2 \quad (7)$$

$$\frac{\partial f(\cdot)}{\partial(L')} = \operatorname{div}H' - \sigma/2. \quad (8)$$

Let us now find the first partial derivatives of the integrand function  $f(\cdot)$  with respect to vector  $\frac{\partial Z'}{\partial X}$ . We have:

$$\begin{aligned} \frac{\partial f(\cdot)}{\partial(dE'_x/dy)} &= \\ & \frac{\partial}{\partial(dE'_x/dy)} \left( \frac{1}{2} \Re(H', E') - \frac{\varepsilon}{2} \left( E' \frac{dE''}{dt} - E'' \frac{dE'}{dt} \right) - K' \left( \operatorname{div}E' - \frac{\rho}{2} \right) \right) = \\ & \frac{\partial}{\partial(dE'_x/dy)} \left( H' \cdot \operatorname{rot}(E') + E' \cdot \operatorname{rot}(H') - \frac{\varepsilon}{2} \left( E' \frac{dE''}{dt} - E'' \frac{dE'}{dt} \right) - K' \left( \operatorname{div}E' - \frac{\rho}{2} \right) \right) = \\ & \frac{\partial}{\partial(dE'_x/dy)} \left( H' \cdot \frac{\partial \operatorname{rot}(E')}{\partial(dE'_x/dy)} - K' \frac{\partial \operatorname{div}E'}{\partial(dE'_x/dy)} \right) = \\ & H' \cdot (0, 0, -1) - K'. \end{aligned}$$

Thus,

$$\frac{\partial f(\cdot)}{\partial(dE'_x/dy)} = -H'_z - K'. \quad (9)$$

Table 2 is filled in the same way.

We have also:

$$\frac{\partial f(\cdot)}{\partial(dE'/dt)} = \frac{\varepsilon}{2} E'', \quad \frac{\partial f(\cdot)}{\partial(dH'/dt)} = -\frac{\mu}{2} H''. \quad (10)$$

Table 2.

|  | $\frac{\partial f(\cdot)}{\partial(\partial E'_a/\partial b)}$               | $\frac{\partial f(\cdot)}{\partial(\partial H'_a/\partial b)}$               |
|--|--|--|
|  | $\frac{\partial f(\cdot)}{\partial(\partial E'_x/\partial y)} = -H'_z - K'.$ | $\frac{\partial f(\cdot)}{\partial(\partial H'_x/\partial y)} = -E'_z + L'.$ |
|  | $\frac{\partial f(\cdot)}{\partial(\partial E'_x/\partial z)} = H'_y - K'.$  | $\frac{\partial f(\cdot)}{\partial(\partial H'_x/\partial z)} = E'_y + L'.$  |
|  | $\frac{\partial f(\cdot)}{\partial(\partial E'_y/\partial x)} = H'_z - K'.$  | $\frac{\partial f(\cdot)}{\partial(\partial H'_y/\partial x)} = E'_z + L'.$  |
|  | $\frac{\partial f(\cdot)}{\partial(\partial E'_y/\partial z)} = -H'_x - K'.$ | $\frac{\partial f(\cdot)}{\partial(\partial H'_y/\partial z)} = -E'_x + L'.$ |
|  | $\frac{\partial f(\cdot)}{\partial(\partial E'_z/\partial x)} = -H'_y - K'.$ | $\frac{\partial f(\cdot)}{\partial(\partial H'_z/\partial x)} = -E'_y + L'.$ |
|  | $\frac{\partial f(\cdot)}{\partial(\partial E'_z/\partial y)} = H'_x - K'.$  | $\frac{\partial f(\cdot)}{\partial(\partial H'_z/\partial y)} = E'_x + L'.$  |

### 1.5. Second Partial Derivatives

Let us now find the non-zero second partial derivatives for functions with one stroke. For this sake we shall differentiate (4.9) with respect to  $H_x$ . The results are brought together in the Table 1, where the results of double differentiation are given, and the formulas symmetry is taken into account, thanks to which the results were doubled. Every element of the table shows the value of the second derivative of the function  $f(\cdot)$  with respect of the pair of functions that are named in the heading of corresponding row and column.

Table 1.

|        | $\frac{\partial E'_z}{\partial y}$ | $\frac{\partial E'_y}{\partial z}$ | $\frac{\partial E'_x}{\partial z}$ | $\frac{\partial E'_z}{\partial x}$ | $\frac{\partial E'_y}{\partial x}$ | $\frac{\partial E'_x}{\partial y}$ |
|--------|------------------------------------|------------------------------------|------------------------------------|------------------------------------|------------------------------------|------------------------------------|
| $H'_x$ | 1                                  | -1                                 | 0                                  | 0                                  | 0                                  | 0                                  |
| $H'_y$ | 0                                  | 0                                  | 1                                  | -1                                 | 0                                  | 0                                  |
| $H'_z$ | 0                                  | 0                                  | 0                                  | 0                                  | 1                                  | -1                                 |

Keeping in mind the definition of rotor and definition of derivative by vector, we shall rewrite Table 1 as Table 2, where the rotors coordinates are shown.

Table 2.

|        | $\text{rot}_x(E')$ | $\text{rot}_y(E')$ | $\text{rot}_z(E')$ |
|--------|--------------------|--------------------|--------------------|
| $H'_x$ | 1                  | 0                  | 0                  |
| $H'_y$ | 0                  | 1                  | 0                  |
| $H'_z$ | 0                  | 0                  | 1                  |

Finally, keeping in mind the definition of derivative by vector, we shall rewrite the Table 2 as Table 3, where the values of the second derivative of function  $f(\cdot)$  with respect to a pair of vector-functions are shown.

Table 3.

|      | $\text{rot}(E')$ |
|------|------------------|
| $H'$ | 1                |

Thus,

$$\frac{\partial^2 f(\cdot)}{\partial(H')\partial\left(\frac{\partial E'}{\partial X}\right)} = 1, \tag{1a}$$

By symmetry in formula (1.1) we also get

$$\frac{\partial^2 f(\cdot)}{\partial(E')\partial\left(\frac{\partial H'}{\partial X}\right)} = -1. \tag{1b}$$

So, the second partial derivatives of function  $f(\cdot)$ , included in the formula (3.18),

$$\frac{\partial^2 f(Z)}{\partial Z^2} = 0, \quad \frac{\partial^2 f(Z)}{\partial Q^2} = 0, \tag{2}$$

The integration element in (3.18) takes the form

$$Z \frac{\partial^2 f(\cdot)}{\partial Z' \partial Q} Q = (E', H') \frac{\partial^2 f(\cdot)}{\partial (E', H') \partial \left( \frac{\partial E'}{\partial X}, \frac{\partial H'}{\partial X} \right)} \left( \frac{\partial E'}{\partial X}, \frac{\partial H'}{\partial X} \right) \quad (4)$$

or

$$Z \frac{\partial^2 f(\cdot)}{\partial Z' \partial Q} Q = E' \frac{\partial^2 f(\cdot)}{\partial (E') \partial \left( \frac{\partial H'}{\partial X} \right)} \cdot \frac{\partial H'}{\partial X} + H' \frac{\partial^2 f(\cdot)}{\partial (H') \partial \left( \frac{\partial E'}{\partial X} \right)} \cdot \frac{\partial E'}{\partial X}$$

or, taking into account (1a, 1b),

$$Z \frac{\partial^2 f(\cdot)}{\partial Z' \partial Q} Q = E' \cdot \frac{\partial H'}{\partial X} - H' \cdot \frac{\partial E'}{\partial X} \quad (5)$$

or

$$Z \frac{\partial^2 f(\cdot)}{\partial Z' \partial Q} Q = E' \cdot \text{rot}(H') - H' \cdot \text{rot}(E') \quad (6)$$

Thus, (3.18) is transformed into

$$\frac{\partial^2 \Delta \Phi}{\partial a^2} = \int_X [E' \cdot \text{rot}(H') - H' \cdot \text{rot}(E')] dX \quad (7)$$

The expression in the right side of (7) is the flow of energy through the surface bounding this volume. This flow does not change its sign (which follows of the physics of electromagnetic waves propagation). Therefore the integral (7) is a value of fixed sign. From this according to 2 it follows that the functional  $\Phi$  has global strong minimum with respect to the  $Z'$ .

By symmetry functional  $\Phi$  has a global strong maximum with respect to the function  $Z''$ .

The above cited is, in essence, the proof of the following theorem.

**Theorem 1.** Functional  $\Phi$ , determined in (2.1) with respect to the functions  $Z' = [E', H', K', L']$  and  $Z'' = [E'', H'', K'', L'']$ , has a global saddle extremal where a strong minimum with respect to  $Z'$  and a strong maximum with respect to  $Z''$  is achieved. The functions on this extremal are such, that  $Z' = Z''$ , and their sum  $Z = Z' + Z'' = [E, H, K, L]$  satisfies the Maxwell equations.



## 2. Computational Aspect

Consider vector-function

$$q^T = |E_x, E_y, E_z, H_x, H_y, H_z, K, L| \quad (5)$$

and vector-functions

$$\left(\frac{dq}{dm}\right)^T = \left|\frac{dE_x}{dm}, \frac{dE_y}{dm}, \frac{dE_z}{dm}, \frac{dH_x}{dm}, \frac{dH_y}{dm}, \frac{dH_z}{dm}, \frac{dK}{dm}, \frac{dL}{dm}\right|, \quad (6)$$

where  $m = \{x, y, z, t\}$ . We shall also consider vector-functions

$q', q'', \frac{dq'}{dm}, \frac{dq''}{dm}$ , where the components are functions  $E, H$  and their

derivatives with one or two strokes correspondingly. Then the functional (9.1.2.1) may be rewritten as

$$\Phi = \int_0^T \left\{ \iiint_{x,y,z} \left[ \begin{array}{l} q'^T R_x \frac{dq''}{dx} - q''^T R_x \frac{dq'}{dx} \\ q'^T R_y \frac{dq''}{dy} - q''^T R_y \frac{dq'}{dy} \\ q'^T R_z \frac{dq''}{dz} - q''^T R_z \frac{dq'}{dz} \\ q'^T R_t \frac{dq''}{dt} - q''^T R_t \frac{dq'}{dt} \\ - (q'^T - q''^T) U \end{array} \right] dx dy dz \right\} dt, \quad (7)$$

where  $U = -\left|0, 0, 0, 0, 0, 0, \frac{\rho}{\varepsilon}, \frac{-\sigma}{\mu}\right|$ ,

|   | $R_x$ |   |    |   |    |    | $R_y$ |    |   |    |  |    |
|---|-------|---|----|---|----|----|-------|----|---|----|--|----|
| 1 |       |   |    |   |    | -1 |       |    |   |    |  | 1  |
| 2 |       |   |    |   | -1 |    |       |    |   |    |  | -1 |
| 3 |       |   |    | 1 |    |    |       |    |   | -1 |  |    |
| 4 |       |   |    |   |    | 1  |       |    | 1 |    |  |    |
| 5 |       |   | -1 |   |    |    |       |    |   |    |  | 1  |
| 6 |       | 1 |    |   |    |    | -1    |    |   |    |  |    |
| 7 | -1    |   |    |   |    |    |       | -1 |   |    |  |    |
| 8 |       |   |    | 1 |    |    |       |    |   | 1  |  |    |

|   | $R_z$ |    |    |    |   |    | $R_t$          |                |                |       |       |       |  |  |
|---|-------|----|----|----|---|----|----------------|----------------|----------------|-------|-------|-------|--|--|
| 1 |       |    |    | -1 |   |    | $-\varepsilon$ |                |                |       |       |       |  |  |
| 2 |       |    | 1  |    |   |    |                | $-\varepsilon$ |                |       |       |       |  |  |
| 3 |       |    |    |    |   | -1 |                |                | $-\varepsilon$ |       |       |       |  |  |
| 4 |       | -1 |    |    |   |    |                |                |                | $\mu$ |       |       |  |  |
| 5 | 1     |    |    |    |   |    |                |                |                |       | $\mu$ |       |  |  |
| 6 |       |    |    |    |   | 1  |                |                |                |       |       | $\mu$ |  |  |
| 7 |       |    | -1 |    |   |    |                |                |                |       |       |       |  |  |
| 8 |       |    |    |    | 1 |    |                |                |                |       |       |       |  |  |

By analogy with the corollary 4.1.1 the secondary functional that corresponds to the functional (7)

$$\Phi = \int_0^T \left\{ \iiint_{x,y,z} \left[ \left( R_x^T \frac{dq}{dx} + R_y^T \frac{dq}{dy} + R_z^T \frac{dq}{dz} \right)^T q + \left( \frac{dq}{dt} \right)^T R_t q - 4q^T U \right] dx dy dz \right\} dt, \quad (8)$$

where

$$q = q' + q'' . \quad (9)$$

Its quasivariation with respect to every variable (5) is

$$p = R_x^T \frac{dq}{dx} + R_y^T \frac{dq}{dy} + R_z^T \frac{dq}{dz} + R_t^T \frac{dq}{dt} - 2U^T . \quad (10)$$

For  $p = 0$  the equation system (10) turns into the Maxwell equations system (9.1.2.9-9.1.2.12) in a more detailed form:

|    |   |       |
|----|---|-------|
| 1. | $\frac{\partial H_z}{\partial y} - \frac{\partial H_y}{\partial z} - \varepsilon \frac{\partial E_x}{\partial t} - \frac{dK}{dx} = 0$ |       |
| 2. | $\frac{\partial H_x}{\partial z} - \frac{\partial H_z}{\partial x} - \varepsilon \frac{\partial E_y}{\partial t} - \frac{dK}{dy} = 0$ |       |
| 3. | $\frac{\partial H_y}{\partial x} - \frac{\partial H_x}{\partial y} - \varepsilon \frac{\partial E_z}{\partial t} - \frac{dK}{dz} = 0$ |       |
| 4. | $\frac{\partial E_z}{\partial y} - \frac{\partial E_y}{\partial z} + \mu \frac{\partial H_x}{\partial t} + \frac{dL}{dx} = 0$         | (10a) |

|    |   |  |
|----|---|--|
| 5. | $\frac{\partial E_x}{\partial z} - \frac{\partial E_z}{\partial x} + \mu \frac{\partial H_y}{\partial t} + \frac{dL}{dy} = 0$         |  |
| 6. | $\frac{\partial E_y}{\partial x} - \frac{\partial E_x}{\partial y} + \mu \frac{\partial H_z}{\partial t} + \frac{dL}{dz} = 0$         |  |
| 7. | $-\frac{\partial E_x}{\partial x} - \frac{\partial E_y}{\partial y} - \frac{\partial E_z}{\partial z} + \frac{\rho}{\varepsilon} = 0$ |  |
| 8. | $\frac{\partial H_x}{\partial x} + \frac{\partial H_y}{\partial y} + \frac{\partial H_z}{\partial z} - \frac{\sigma}{\mu} = 0$        |  |

Their solution may be obtained with the use of the method of descent along the quasivariation, considered above in its application to electric circuits. Let

$$\mathbf{q} = q_t \mathbf{o} q_x \mathbf{o} q_y \mathbf{o} q_z, \quad (11)$$

where  $q_t, q_x, q_y, q_z$  depend only on  $t, x, y, z$  accordingly. The symbol  $(\mathbf{o})$  denotes the component-wise multiplication of vectors

$$\mathbf{U} = U_t \mathbf{o} U_x \mathbf{o} U_y \mathbf{o} U_z, \quad (12)$$

Further for brevity sake we shall write  $\underline{q}_t = q_x \mathbf{o} q_y \mathbf{o} q_z$ ,  $\underline{q}_x = q_t \mathbf{o} q_y \mathbf{o} q_z$ ,  $\underline{q}_y = q_t \mathbf{o} q_x \mathbf{o} q_z$ ,  $\underline{q}_z = q_t \mathbf{o} q_x \mathbf{o} q_y$ . Let us rewrite (8) in this notations

$$\Phi = \int_0^T \left\{ \iiint_{x,y,z} \{\Phi_o\} dx dy dz \right\} dt. \quad (13)$$

Taking into account the adopted assumptions and notations, the integrand (13) will take the form:

$$\Phi_0 = \left\{ \begin{array}{l} \left( R_x \left( \frac{dq_x}{dx} \circ q_t \circ q_y \circ q_z \right) + \right. \\ \left. + R_y \left( \frac{dq_y}{dy} \circ q_t \circ q_x \circ q_z \right) + \right. \\ \left. + R_z \left( \frac{dq_z}{dz} \circ q_t \circ q_x \circ q_y \right) + \right. \\ \left. + R_t \cdot \left( \frac{dq_t}{dt} \circ q_x \circ q_y \circ q_z \right) \right)^T \\ \left. + (q_t \circ q_x \circ q_y \circ q_z)^T \cdot (U_t \circ U_x \circ U_y \circ U_z) \right\}. \quad (14)$$

Consider now the functional (13, 14) with fixed functions  $q_t, q_y, q_z$  depending only on the functions of independent variable  $x$ . After complicated transformations (13, 14) may be presented in the form

$$\Phi = \int_x \left\{ q_x^T S_x q_x + \left( \frac{dq_x}{dx} \right)^T \bar{R}_x q_x + q_x^T V_x \right\} dx, \quad (15)$$

where

$$\begin{aligned} \bar{R}_x &= \iiint_{t,y,z} f_r(R_x, \underline{q}_x) dt dy dz, \\ S_x &= \iiint_{t,y,z} f_s \left( R_t, R_y, R_z, \underline{q}_x, \frac{dq_y}{dy}, \frac{dq_z}{dz}, \frac{dq_t}{dt} \right) dt dy dz, \\ V_x &= U_x \iiint_{t,y,z} f_v(\underline{q}_x, \underline{U}_x) dt dy dz. \end{aligned} \quad (16)$$

Notice that the expression (15) is equivalent to the functional (4.1.12), and the method for seeking its stationary value was described in 4.1.1 and amounts to the solution of quasivariation equation (4.1.15). In our case this equation takes the following form

$$S_x q_x + \bar{R}_x \left( \frac{dq_x}{dx} \right) + V_x = 0, \quad (17)$$

Note, that the expression (15) is equivalent to the quasivariation (4.1.12) of the secondary functional, for which the method of finding a stationary value was described in the Theorem 4.1.1.

So, for fixed functions  $q_t, q_y, q_z$  it is possible to find a function  $q_x$ , that is the stationary value, bringing extremum to the functional (13, 14). Similar expressions may be obtained for the functions  $q_t, q_y, q_z$  when the three other functions are fixed.

To find the stationary value of the function  $q$ , defined as (11), coordinate-wise descent along each independent variable  $m = \{x, y, z, t\}$  should be performed.

Note also that the functional (2.8) is equivalent to functional

$$\Phi = \int_0^T \left\{ \iiint_{x,y,z} \left\{ \mathfrak{R}(H, E) + H \cdot \frac{dH}{dt} - E \cdot \frac{dE}{dt} - K \cdot \left( \text{div}E - \frac{\rho}{\varepsilon} \right) + L \cdot \left( \text{div}H - \frac{\sigma}{\mu} \right) \right\} dx dy dz \right\} dt. \quad (18)$$

### 3. Nonlinear Maxwell Equations

The space in which the electromagnetic field is spreading may be heterogeneous. It is expressed in the fact that magnetic permeability  $\mu$  and dielectric permittivity  $\varepsilon$  depend on the space coordinates, i.e. they are vector-functions of these coordinates. We shall restrict our consideration by the case, when each coordinate of vector  $\mu$  or  $\varepsilon$  depends only on one space coordinate of the same name.

Consider functional that takes into account the field heterogeneity. For this we shall rewrite the equations (9.1.2.9, 9.1.2.10) in the following form

$$\text{rot}H - \varepsilon \circ \frac{dE}{dt} - \text{grad}(K) = 0, \quad (1)$$

$$\text{rot}E + \mu \circ \frac{dH}{dt} - \text{grad}(L) = 0, \quad (2)$$

where the symbol  $\{\circ\}$  denotes the operation of componentwise multiplication of vectors. The equations (1, 2, 1.11, 1.12) are quasivariation equations for the functional

$$\Phi = \int_0^T \left\{ \iiint_{x,y,z} \left\{ \mathfrak{S}(H, E) + H \cdot \frac{dH}{dt} - E \cdot \frac{dE}{dt} - K \cdot \left( \text{div}E - \frac{\rho}{\varepsilon} \right) + L \cdot \left( \text{div}H - \frac{\sigma}{\mu} \right) \right\} dx dy dz \right\} dt. \quad (18)$$

similar to the functional (2.18). The solution method for equations (1, 2, 1.11, 1.12) of the quasivariation of functional (3) is identical with the solution method for equations (9.1.2.9, 9.1.2.10) of the quasivariation of functional (2.18), despite the dependence of  $\mu$  and  $\varepsilon$  of independent variables. Below we shall illustrate these methods by a specific example.

## 4. Example. The Coaxial Cable Computation

### 4.1. Setting up a Problem

To illustrate the preceding we shall consider a special case of Maxwell equations, namely, the coaxial cable equations – see also Fig. 1. An ideal coaxial cable has a zero active resistance of the wire and ideal dielectric, filling the space between the central wire and the outward sheath. The cable is connected to a voltage source. The electromagnetic field of the cable has an axial symmetry by the axis perpendicular to the figure’s plane. Hence it is advisable to consider it in a cylindrical coordinate system, where the axis  $z$  is directed along the cable axis, and the coordinates  $r$  and  $\varphi$  are directed as it is shown on the Figure 1. Then the field intensity vector will have a component directed only along the arc  $\varphi$ :

$$H = H_\varphi, \quad H_r = H_z = 0.$$

Disregarding the conductors resistance,  $E_z = 0$ , and the electric field intensity vector will have only a component directed along the radius

$$E = E_r, \quad E_\varphi = E_z = 0.$$

In cylindrical coordinates  $r, \varphi, z$ , as it is well known [14], the scalar divergence of the vector  $H$ , vector gradient of the scalar function  $a(x, y, z)$ , vector rotor of the vector  $H$  are accordingly

$$\text{div}(H) = \left( \frac{H_r}{r} + \frac{\partial H_r}{\partial r} + \frac{1}{r} \cdot \frac{\partial H_\varphi}{\partial \varphi} + \frac{\partial H_z}{\partial z} \right), \quad (a)$$

$$\text{grad}_r(a) = \frac{\partial a}{\partial r}, \quad \text{grad}_\varphi(a) = \frac{1}{r} \cdot \frac{\partial a}{\partial \varphi}, \quad \text{grad}_z(a) = \frac{\partial a}{\partial z}, \quad (\text{b})$$

$$\text{rot}_r(H) = \left( \frac{1}{r} \cdot \frac{\partial H_z}{\partial \varphi} - \frac{\partial H_\varphi}{\partial z} \right), \quad (\text{c})$$

$$\text{rot}_\varphi(H) = \left( \frac{\partial H_r}{\partial z} - \frac{\partial H_z}{\partial r} \right), \quad (\text{d})$$

$$\text{rot}_z(H) = \left( \frac{H_\varphi}{r} + \frac{\partial H_\varphi}{\partial r} - \frac{1}{r} \cdot \frac{\partial H_r}{\partial \varphi} \right). \quad (\text{e})$$

Between ideal dielectric-1 and the cable sheath we will post dielectric-2 with some conductivity (to illustrate the method of calculation) This distinguishes the present embodiment from the conventional embodiment. For electromagnetic field in the dielectric-2 the Maxwell equations take the following form:

$$\frac{\partial H_\varphi}{\partial z} + \varepsilon \frac{\partial E_r}{\partial t} + J_z = 0, \quad (1)$$

$$\frac{\partial E_r}{\partial z} + \mu \frac{\partial H_\varphi}{\partial t} = 0, \quad (2)$$

where

$H = H_\varphi$  – magnetic field intensity directed along an arc,

$E = E_r$  – electric field intensity directed along a radius,

$J = J_z$  – electric current density in dielectric-2 created by voltage source connected to the cable in the point  $z=0$ .

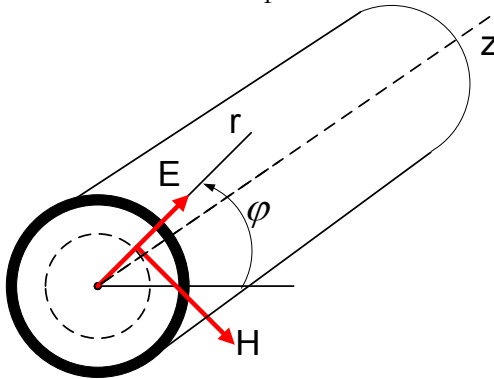

Fig. 1. Coaxial cable

These equations correspond to equations (9.1.2.9, 9.1.2.10). All their terms are functions of time  $t$  and coordinate  $z$ . The density of electric current  $J$  is created by voltage source  $u$ , connected to the cable in the point  $z=0$ . Thus,

$$J = -\beta \frac{\partial u}{\partial z}. \quad (3)$$

where  $\beta$  – conductivity of the dielectric-2 (rather than the central wire) cable in a given point. Hence the equation (1) may be rewritten as

$$\frac{\partial H}{\partial z} + \varepsilon \frac{\partial E}{\partial t} - \beta \frac{\partial u}{\partial z} = 0. \quad (4)$$

Let

$$u = v \cdot \text{Sin}(\omega t). \quad (5)$$

First we shall consider the known solution of the equations (1, 4) with  $z > 0$  and infinitely heavy cable load, i.e. the equations (2) and

$$\frac{\partial H}{\partial z} + \varepsilon \frac{\partial E}{\partial t} = 0. \quad (6)$$

It is [25]:

$$\begin{aligned} E &= E_1 \text{Cos}(\omega t) \text{Sin}(\kappa z), \\ H &= H_1 \text{Sin}(\omega t) \text{Cos}(\kappa z), \end{aligned} \quad (7)$$

Substituting this solution into (2) and (6), we find

$$\kappa = \omega \sqrt{\varepsilon \mu}, \quad (8)$$

$$\frac{E_1}{H_1} = -\frac{\omega \mu}{\kappa} = -\frac{\kappa}{\omega \varepsilon}. \quad (9)$$

#### 4.2. Functional of the problem

Our problem is as follows. The equations (2, 4, 5) and the values  $\varepsilon, \mu, \omega, \beta, v$  are known. We need to find the form of the functions  $E(t, z)$ ,  $H(t, z)$ , and if it would be shown that the solution has the form of (10), then we have to find also the values  $E$ ,  $H$ ,  $\kappa$ . We shall seek the solution in the form

$$\begin{aligned} H(t, z) &= h_t \cdot h_z, \\ E(t, z) &= e_t \cdot e_z, \end{aligned} \quad (10)$$

where  $h_t$ ,  $e_t$ ,  $h_z$ ,  $e_z$  - unknown functions. The function  $u$ , given in the sole point  $z=0$ , is naturally defined as



$$V(t, z) = \gamma'(z) \cdot v \cdot \text{Sin}(\omega t) \quad (11)$$

where  $\gamma'(z)$  is Dirac function – see section 6.6. Assuming that the derivative of Dirac function is  $\gamma''(z) = -\gamma'(z)$ , we find

$$\frac{\partial u(t, z)}{\partial z} = -\gamma'(z) \cdot v \cdot \text{Sin}(\omega t) \quad (13)$$

Then the equation (4) will be

$$\frac{\partial H}{\partial z} + \varepsilon \frac{\partial E}{\partial t} + \gamma'(z) \cdot v \beta \cdot \text{Sin}(\omega t) = 0. \quad (14)$$

Let us apply the above described method to this problem. We shall denote

$$q = \begin{vmatrix} H \\ E \end{vmatrix}, \quad q(t, z) = q_t \circ q_z, \quad q_t = \begin{vmatrix} h_t \text{Sin}(\omega t) \\ e_t \text{Cos}(\omega t) \end{vmatrix}, \quad q_z = \begin{vmatrix} h_z \\ e_z \end{vmatrix},$$

$$\left( \frac{dq}{dz} \right)^T = \begin{vmatrix} dE \\ dH \end{vmatrix}, \quad \left( \frac{dq}{dt} \right)^T = \begin{vmatrix} dE \\ H \end{vmatrix},$$

$$U = \beta \cdot \begin{vmatrix} u \\ 0 \end{vmatrix}, \quad U = U_t \circ U_z, \quad U_t = \begin{vmatrix} -\beta v \text{Sin}(\omega t) \\ 0 \end{vmatrix}, \quad U_z = \begin{vmatrix} \gamma'(z) \\ 0 \end{vmatrix}.$$

Then the equations (2, 14) will assume the form

$$\left( \frac{dq}{dz} \right)^T R_z + \left( \frac{dq}{dt} \right)^T R_t - U = 0,$$

where

$$R_z = \begin{vmatrix} 1 & 0 \\ 0 & 1 \end{vmatrix}, \quad R_t = \begin{vmatrix} 0 & \mu \\ \varepsilon & 0 \end{vmatrix}.$$

Functional (9.2.8) in this case will take the form:

$$\Phi = \int_0^T \left\{ \int_0^Z \left[ \left( \frac{dq}{dz} \right)^T R_z q + \left( \frac{dq}{dt} \right)^T R_t q - q^T U \right] dz \right\} dt$$

or

$$\Phi = \int_0^T \left\{ \int_0^Z \left[ \left( \frac{dq_z}{dz} \circ q_t \right)^T R_z (q_z \circ q_t) + \left( q_z \circ \frac{dq_t}{dt} \right)^T R_t (q_z \circ q_t) - (q_z \circ q_t)^T U \right] dz \right\} dt$$

or

$$\Phi = \int_0^T \left\{ \int_0^Z \left[ \left( \frac{dh_z}{dz} h_t \right) (h_z h_t) + \left( \frac{de_z}{dz} e_t \right) (e_z e_t) \right. \right. \\ \left. \left. + \left( e_z \frac{de_t}{dt} \right) \varepsilon (h_z h_t) + \left( h_z \frac{dh_t}{dt} \right) \mu (e_z e_t) \right] dz \right\} dt \cdot \quad (15)$$

$$\left. \left. \left. \left. \left. - (h_z h_t \beta v \sin(\omega t)) \gamma'(z) \right) \right) \right) \right) \right)$$

### 4.3. The Solution of the Problem with Fixed Functions of Time

Let us consider this functional with fixed functions of time  $q_t$  depending only on the functions of independent variable  $z$ . Assuming here that

$$H(t, z) = h_t \sin(\omega t) \cdot h_z, \quad (16)$$

$$E(t, z) = e_t \cos(\omega t) \cdot e_z,$$

where  $h_t, e_t$  - known numbers,  $h_z, e_z$  - unknown functions . Тогда

$$\Phi = \int_0^Z \left\{ \left( \frac{dh_z}{dz} R_{11} e_z \right) + \left( \frac{de_z}{dz} R_{22} h_z \right) \right\} dz, \quad (17)$$

$$\left. \left. \left. \left. \left. - (\varepsilon S_{12} h_z^2) - (\mu S_{21} e_z^2) - h_z U_{t1} \gamma'(z) \right) \right) \right) \right)$$

где

$$S_{12} = \int_0^T \left\{ \omega e_t h_t \sin^2(\omega t) dt \right\} \quad S_{21} = \int_0^T \left\{ \omega e_t h_t \cos^2(\omega t) dt \right\}$$

$$R_{11} = \int_0^T \left\{ h_t^2 \sin^2(\omega t) dt \right\}, \quad R_{22} = \left( \int_0^T \left\{ e_t^2 \cos^2(\omega t) dt \right\} \right),$$

$$U_{t1} = - \int_0^T \left\{ \beta v h_t \sin^2(\omega t) dt \right\}.$$

Denote:

$$a = \int_0^T \left\{ \sin^2(\omega t) dt \right\} = \int_0^T \left\{ \cos^2(\omega t) dt \right\}.$$

Taking this into account, we find

$$\begin{aligned}
 R_{11} &= ah_t^2, \quad R_{22} = ae_t^2, \quad S_{12} = -a\omega e_t h_t, \quad S_{21} = a\omega e_t h_t, \\
 U_{t1} &= -a\beta v h_t.
 \end{aligned} \tag{18}$$

Taking this into account, we find

$$\Phi = \int_0^Z \left\{ \left( \left( \frac{dq_z}{dz} \right)^T \bar{R}_z q_z \right) + \left( q_z^T S_z q_z \right) - U_{t1}(h_z \gamma'(z)) \right\} dz, \tag{19}$$

where

$$\begin{aligned}
 \bar{R}_z &= \begin{vmatrix} R_{11} & 0 \\ 0 & R_{22} \end{vmatrix} = \begin{vmatrix} h_t^2 & 0 \\ 0 & e_t^2 \end{vmatrix}, \\
 S_z &= \begin{vmatrix} 0 & \varepsilon S_{12} \\ \mu S_{21} & 0 \end{vmatrix} = \omega e_t h_t \begin{vmatrix} 0 & -\varepsilon \\ \mu & 0 \end{vmatrix}.
 \end{aligned} \tag{20}$$

The quasivariation (4.1.13) функционала (19) с учетом утверждения 6.3.1 имеет вид:

$$p_z = S_z q_z + \bar{R}_z \left( \frac{dq_z}{dz} \right) - \begin{vmatrix} U_{t1} \\ 0 \end{vmatrix} \cdot \gamma'(z)$$

Thus, on this stage the optimization consists in the solution of equation

$$S_z q_z + \bar{R}_z \left( \frac{dq_z}{dz} \right) - \begin{vmatrix} U_{t1} \\ 0 \end{vmatrix} \cdot \gamma'(z) = 0. \tag{21}$$

The method, algorithm and program for solving such equation are given in section 6.6. For  $e_t = h_t = 1$  in an extended form this equation takes the form

$$\begin{cases} -\omega \varepsilon \cdot e_z + \frac{dh_z}{dz} + u \gamma'(z) = 0, \\ \omega \mu \cdot h_z + \frac{de_z}{dz} = 0, \end{cases} \tag{22}$$

where

$$u = -\beta \cdot v, \tag{23}$$

and its solution – the form

$$\begin{cases} h_z = -u(\text{Cos}(\kappa z) - \gamma(z)H_o), \\ e_z = -u\sqrt{\frac{\mu}{\varepsilon}} \cdot \text{Sin}(\kappa z) \end{cases} \tag{24}$$

$$\kappa = \omega \sqrt{\varepsilon \mu} \tag{25}$$

Combining (16) and (24), we obtain

$$H(t, z) = -uh_t \text{Sin}(\omega t) \cdot (\text{Cos}(\kappa z) + \gamma(z)H_o),$$

$$E(t, z) = -e_t u \sqrt{\frac{\mu}{\varepsilon}} \text{Cos}(\omega t) \text{Sin}(\kappa z) \tag{25a}$$

So, in a dielectric-2 appear

- 1) standing electromagnetic wave,
 
$$H_1(t, z) = -uh_t \text{Sin}(\omega t) \cdot \text{Cos}(\kappa z),$$

$$E(t, z) = -e_t u \sqrt{\frac{\mu}{\varepsilon}} \text{Cos}(\omega t) \text{Sin}(\kappa z),$$
- 2) static magnetic field,
 
$$H_2(t, z) = H_o \cdot \text{Sin}(\beta z)$$

**Example 1.** Let (16) and

$$u = -55, \quad \frac{e_t}{h_t} = 1, \quad \omega = 10, \quad \mu = 0.2, \quad \varepsilon = 3.2.$$

be fulfilled. The equation (21) then will be:

$$\begin{vmatrix} 0 & -\omega\varepsilon \\ \omega\mu & 0 \end{vmatrix} \cdot q_z + \begin{vmatrix} 1 & 0 \\ 0 & 1 \end{vmatrix} \cdot \left( \frac{dq_z}{dz} \right) - \begin{vmatrix} -55 \\ 0 \end{vmatrix} \cdot \gamma'(z) = 0.$$

From this it follows that

$$h_z = -A_h \cdot \text{Cos}(\kappa z), \quad e_z = A_e \cdot \text{Sin}(\kappa z), \quad \kappa = 8,$$

$$\frac{\partial h(z)}{\partial z} = \kappa A_h \cdot \text{Sin}(\kappa z), \quad \frac{\partial e(z)}{\partial z} = \kappa A_e \cdot \text{Cos}(\kappa z),$$

where  $A_h = 55$ ,  $A_e = A_h \sqrt{\frac{\mu}{\varepsilon}} = 13.75$ . It is easy to see that the value  $\kappa$  satisfies the condition (8). Thus, the solution of this problem is found on the first iteration:

$$H = -55 \text{Sin}(\omega t) \text{Cos}(\kappa z), \quad E = 13.75 \text{Cos}(\omega t) \text{Sin}(\kappa z).$$

It corresponds by its form to formula (7). Substituting this solution to (2) and (6), we find:

$$\frac{\partial E}{\partial z} + \mu \frac{\partial H}{\partial t} = \text{Cos}(\omega t) \text{Cos}(\kappa z) (13.75 \kappa - 55 \mu \omega) = 0,$$

$$\frac{\partial H}{\partial z} + \varepsilon \frac{\partial E}{\partial t} = \text{Sin}(\omega t) \text{Sin}(\kappa z) (55\kappa - 13.75\varepsilon\omega) = 0,$$

and in the point  $z = 0$  the condition  $A_h = u$  is fulfilled, which was to be proved.

**Example 2.** Let us consider also the program for solving the equation (21) or (22), using the method described in section 6.6. It is easy to see that the solution is of the form (24) – see the next figure and function `testDirak6`.

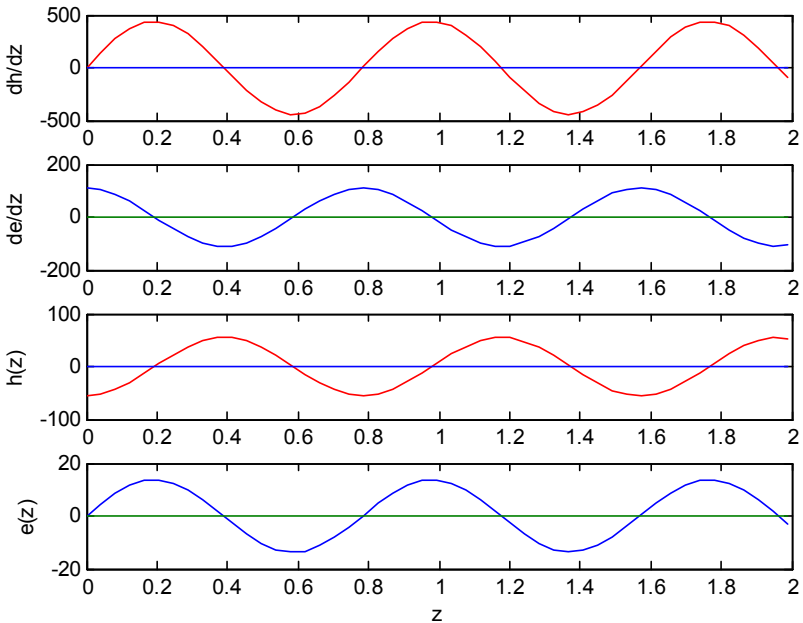

#### 4.4. The Solution of the Problem with Fixed Functions of Variable $z$

In Example 1 it was shown that with known functions of time  $h_t$ ,  $e_t$  the functions  $h_z$ ,  $e_z$  of variable  $z$  may be found, taking the form (24) and

$$\frac{\partial h(z)}{\partial z} = -\kappa u \cdot \text{Sin}(\kappa z) - u\gamma'(z), \quad \frac{\partial e(z)}{\partial z} = -\kappa u \sqrt{\frac{\mu}{\varepsilon}} \cdot \text{Cos}(\kappa z), \quad (26)$$

Now we shall assume that the latter functions are known, and shall look for the functions  $h_t$ ,  $e_t$ . Let us consider the functional (15) with

fixed functions  $q_z$ , depending only on the functions of independent variable  $t$ :

$$\Phi = \int_0^T \left\{ \begin{aligned} & \left( S_{11} h_t^2 \right) + \left( S_{22} e_t^2 \right) \\ & \left( \frac{de_t}{dt} \varepsilon R_{12} h_t \right) + \left( \frac{dh_t}{dt} \mu R_{21} e_t \right) \\ & - U_{z1} (h_t \sin(\omega t)) \end{aligned} \right\} dt, \quad (27)$$

where

$$\left\{ \begin{aligned} & R_{12} = R_{21} = \int_0^Z \{ e_z h_z \} dz = b \sqrt{\frac{\mu}{\varepsilon}} u^2, \\ & S_{11} = \int_0^Z \left\{ \frac{dh_z}{dz} h_z \right\} dz = -b \kappa u^2, \quad S_{22} = \int_0^Z \left\{ \frac{de_z}{dz} e_z \right\} dz = b \kappa \frac{\mu}{\varepsilon} u^2, \\ & U_{z1} = - \int_0^Z \{ h_z \gamma'(z) \} dz = 0. \end{aligned} \right\}$$

Here

$$b = \int_0^Z \{ \text{Cos}(\kappa z) \text{Sin}(\kappa z) \} dz.$$

From (27) we get:

$$\Phi = \int_0^T \left\{ \left( \left( \frac{dq_t}{dt} \right)^T \bar{R}_t q_t \right) + \left( q_t^T S_t q_t \right) - U_z \right\} dz,$$

where

$$\bar{R}_t = \begin{vmatrix} 0 & \varepsilon R_{12} \\ \mu R_{21} & 0 \end{vmatrix} = bu^2 \sqrt{\frac{\mu}{\varepsilon}} \begin{vmatrix} 0 & \varepsilon \\ \mu & 0 \end{vmatrix},$$

$$S_t = \begin{vmatrix} S_{11} & 0 \\ 0 & S_{22} \end{vmatrix} = b \kappa u^2 \begin{vmatrix} -1 & 0 \\ 0 & \mu/\varepsilon \end{vmatrix}, \quad U_z = 0.$$

The quasivariation (4.1.13) of this functional will look as:

$$p_t = S_t q_t + \bar{R}_t \left( \frac{dq_t}{dt} \right).$$

So we must find the solution of the equations system

$$\begin{aligned} -b\kappa u^2 e_t + bu^2 \sqrt{\frac{\mu}{\varepsilon}} \frac{dh_t}{dt} &= 0, \\ b\kappa^2 \frac{\mu}{\varepsilon} h_t + bu^2 \sqrt{\frac{\mu}{\varepsilon}} \mu \frac{de_t}{dt} &= 0. \end{aligned}$$

Reducing it, we find

$$-\kappa e_t + \sqrt{\varepsilon\mu} \frac{dh_t}{dt} = 0, \quad \kappa h_t + \sqrt{\varepsilon\mu} \frac{de_t}{dt} = 0.$$

After a substitution one may see that the solution of this problem has the following form:

$$h_t = \text{Sin}(\omega t), \quad h_t = \text{Cos}(\omega t), \quad \omega = \kappa / \sqrt{\mu\varepsilon}. \quad (28)$$

Comparing (28) and (16, 25), we notice that the obtained result has been the starting point in the section 6.4.3. So the convergence of iterative process is proved.

#### 4.5. A Cable of Variable Diameter

As it was indicated in section 9.3, the computation method is applicable without any modifications in the case when the magnetic permeability  $\mu$  and dielectric permittivity  $\varepsilon$  are depending on the space coordinates. Let us consider for illustration the computation of cable with variable diameter  $d$ . We may assume that

$$\varepsilon = \bar{\varepsilon} \cdot d(z), \quad \mu = \bar{\mu} \cdot d(z), \quad (30)$$

where  $\bar{\varepsilon}$ ,  $\bar{\mu}$  are known constants, and  $d(z)$  is a known function of independent variable. Having been given, as above, certain fixed values of the electric component in the electromagnetic field, we again get the equation (17), differing only in the fact, that the matrix (16) is presented in the form

$$S_z = \omega \cdot e_t \cdot h_t \cdot d(z) \cdot \begin{vmatrix} 0 & -\bar{\varepsilon} \\ \bar{\mu} & 0 \end{vmatrix}. \quad (31)$$

For the equation of the form (21), where  $R_z$  is a function of  $z$ , we shall use the maximization algorithm 6 – see the remark at the end of section 6.6. However, there is no proof that this algorithm is applicable for the equation of the type (21), where  $S_z$  is a function of  $z$  (though formally it may be used and gives a true solution!). Hence it should be

proved that the equation (21, 24) may be transformed into the form, where  $S_z$  does not depend on  $z$ , and  $R_z$  depends on  $z$ . Let us show it.

The equation (21) with condition (24) is in fact a system of two equations:

$$-\omega e_t h_t \bar{\varepsilon} e_z d(z) + h_t^2 \frac{dh_z}{dz} - U_{t1} \cdot \gamma'(z) = 0,$$

$$\omega e_t h_t \bar{\mu} e_z d(z) + e_t^2 \frac{de_z}{dz} = 0.$$

Evidently, they may be rewritten as:

$$-e_z + \frac{h_t^2}{\omega e_t h_t \bar{\varepsilon} d(z)} \cdot \frac{dh_z}{dz} - \frac{U_{t1}}{\omega e_t h_t \bar{\varepsilon} d(0)} \cdot \gamma'(z) = 0,$$

$$h_z + \frac{e_t^2}{\omega e_t h_t \bar{\mu} d(z)} \frac{de_z}{dz} = 0.$$

Let us present them in matrix form:

$$S'_z q_z + R'_z \left( \frac{dq_z}{dz} \right) - \begin{vmatrix} U_{t1} \\ 0 \end{vmatrix} \cdot \gamma'(z) = 0, \quad (32)$$

where

$$S'_z = \begin{vmatrix} 0 & -1 \\ 1 & 0 \end{vmatrix}, \quad R'_z = \frac{1}{\omega e_t h_t d(z)} \begin{vmatrix} \frac{h_t^2}{\bar{\varepsilon}} & 0 \\ 0 & \frac{e_t^2}{\bar{\mu}} \end{vmatrix}, \quad U_{t1} \frac{U_{t1}}{\omega e_t h_t \bar{\varepsilon} d(0)}.$$

Note, that here  $R'_z(z)$  is a function of  $z$ . The equation (32) may be solved with the aid of maximization algorithm 6.

**Example 3.** Let us add to the conditions of Example 1 condition (30), where  $\bar{\mu} = 0.2$ ,  $\bar{\varepsilon} = 3.2$ . Then the equation (32) will look as:

$$\begin{vmatrix} 0 & -1 \\ 1 & 0 \end{vmatrix} \cdot q_z + \frac{1}{\omega d(z)} \begin{vmatrix} 1/\bar{\varepsilon} & 0 \\ 0 & 1/\bar{\mu} \end{vmatrix} \cdot \left( \frac{dq_z}{dz} \right) - \begin{vmatrix} -55/(\omega \bar{\varepsilon} d(0)) \\ 0 \end{vmatrix} \cdot \gamma'(z) = 0.$$

This equation is being solved in this Example. The next Figure (see also function `testDirak8`) shows the results of solving this equation by the method described in section 6.6, with



$d(z) = 3.4 - 1.1 \cdot t$  (left windows) and with  $d(z) = 0.5 + 0.35 \cdot \text{Sin}(5t)$  (right windows). It may be noted that the frequency of space oscillations depends on  $z$ .

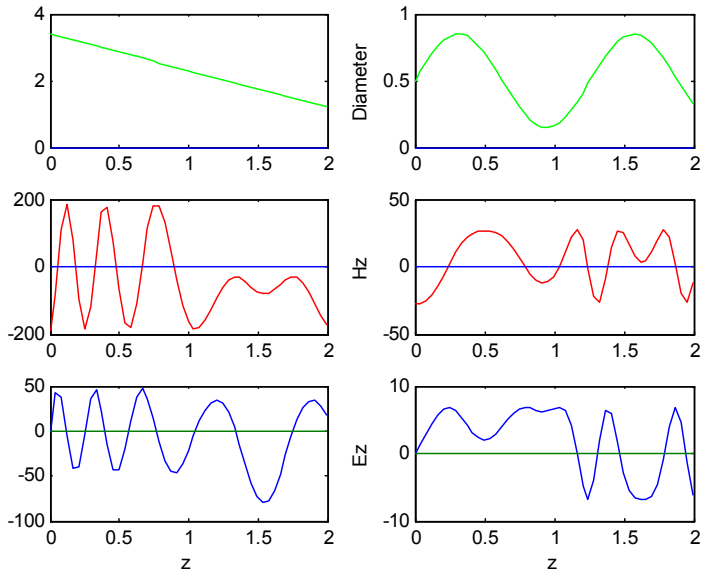

## 5. Computational Aspect - continued

Let us look again at the equation system (9.2.10a). In the first of these equations according to (9.1.2.15)  $\frac{dK}{dx} = -\mathcal{G} \frac{d\varphi}{dx}$ , and in the fourth of these equations according to (9.1.2.17)  $\frac{dL}{dx} = -\zeta \frac{d\phi}{dx}$ . The same remarks may be made for equations (2, 3, 5, 6). So we may rewrite the system (9.2.10a) in the following form:

|    |   |     |
|----|---|-----|
| 1. | $\frac{\partial H_z}{\partial y} - \frac{\partial H_y}{\partial z} - \varepsilon_x \frac{\partial E_x}{\partial t} + \mathcal{G}_x \frac{\partial \varphi}{\partial x} = 0$ |     |
| 2. | $\frac{\partial H_x}{\partial z} - \frac{\partial H_z}{\partial x} - \varepsilon_y \frac{\partial E_y}{\partial t} + \mathcal{G}_y \frac{\partial \varphi}{\partial y} = 0$ |     |
| 3. | $\frac{\partial H_y}{\partial x} - \frac{\partial H_x}{\partial y} - \varepsilon_z \frac{\partial E_z}{\partial t} + \mathcal{G}_z \frac{\partial \varphi}{\partial z} = 0$ |     |
| 4. | $\frac{\partial E_z}{\partial y} - \frac{\partial E_y}{\partial z} + \mu_x \frac{\partial H_x}{\partial t} - \zeta_x \frac{\partial \phi}{\partial x} = 0$                  | (1) |
| 5. | $\frac{\partial E_x}{\partial z} - \frac{\partial E_z}{\partial x} + \mu_y \frac{\partial H_y}{\partial t} - \zeta_y \frac{\partial \phi}{\partial y} = 0$                  |     |
| 6. | $\frac{\partial E_y}{\partial x} - \frac{\partial E_x}{\partial y} + \mu_z \frac{\partial H_z}{\partial t} - \zeta_z \frac{\partial \phi}{\partial z} = 0$                  |     |
| 7. | $-\frac{\partial E_x}{\partial x} - \frac{\partial E_y}{\partial y} - \frac{\partial E_z}{\partial z} + \frac{\rho}{\varepsilon} = 0$                                       |     |
| 8. | $\frac{\partial H_x}{\partial x} + \frac{\partial H_y}{\partial y} + \frac{\partial H_z}{\partial z} - \frac{\sigma}{\mu} = 0$  |     |

In these equations the parameters

$$\varepsilon_x, \varepsilon_y, \varepsilon_z, \mu_x, \mu_y, \mu_z, \mathcal{G}_x, \mathcal{G}_y, \mathcal{G}_z, \zeta_x, \zeta_y, \zeta_z$$

may be the functions of coordinates  $x, y, z$ . If we assume that they differ according to different axes, then we may consider spaces which are threaded by orthogonal strings with conductivities and permeabilities that differ for the strings parallel to different axes.

Below we shall not consider the physical interpretation of our mathematical results. However, as we are using widely the concept of magnetic charges existence, we must mark that the pole of a long magnet from mathematical point of view may be identified with a magnetic charge - see, for example, [38].

Below we do not consider the physical interpretation of mathematical results. Further the concept of the electric charges existence is being widely used. It is known that Heavyside had been to first to introduce the magnetic charges and magnetic currents to the Maxwell's electrodynamics [39]. Let us note also that long magnet pole may be identified in mathematical sense with magnetic charge [38].

Further, unlike (9.2.5, 9.2.6), we shall deal with the vector-function

$$q^T = \left| E_x, E_y, E_z, H_x, H_y, H_z, \varphi, \phi \right| \quad (1a)$$

and vector-functions

$$\left( \frac{dq}{dm} \right)^T = \left| \frac{dE_x}{dm}, \frac{E_y}{dm}, \frac{E_z}{dm}, \frac{H_x}{dm}, \frac{H_y}{dm}, \frac{H_z}{dm}, \frac{\varphi}{dm}, \frac{\phi}{dm} \right|, \quad (1c)$$

and also the matrices

|   | $R_x$ |  |   |    |   |    |            | $R_y$ |  |  |  |  |    |  |  |    |            |
|---|-------|--|---|----|---|----|------------|-------|--|--|--|--|----|--|--|----|------------|
| 1 |       |  |   |    |   |    | $\theta_x$ |       |  |  |  |  | 1  |  |  |    |            |
| 2 |       |  |   |    |   | -1 |            |       |  |  |  |  |    |  |  |    | $\theta_y$ |
| 3 |       |  |   |    | 1 |    |            |       |  |  |  |  | -1 |  |  |    |            |
| 4 |       |  |   |    |   |    |            |       |  |  |  |  | 1  |  |  |    |            |
| 5 |       |  |   | -1 |   |    |            |       |  |  |  |  |    |  |  |    | $-\zeta_y$ |
| 6 |       |  | 1 |    |   |    |            |       |  |  |  |  | -1 |  |  |    |            |
| 7 | -1    |  |   |    |   |    |            |       |  |  |  |  |    |  |  | -1 |            |
| 8 |       |  |   |    | 1 |    |            |       |  |  |  |  |    |  |  |    | 1          |

|   | $R_z$ |  |  |   |    |   |  | $R_t$ |  |  |  |  |  |                |  |  |  |                |
|---|-------|--|--|---|----|---|--|-------|--|--|--|--|--|----------------|--|--|--|----------------|
| 1 |       |  |  |   | -1 |   |  |       |  |  |  |  |  | $-\varepsilon$ |  |  |  |                |
| 2 |       |  |  | 1 |    |   |  |       |  |  |  |  |  |                |  |  |  | $-\varepsilon$ |
| 3 |       |  |  |   |    |   |  |       |  |  |  |  |  |                |  |  |  | $-\varepsilon$ |
| 4 |       |  |  |   |    |   |  |       |  |  |  |  |  |                |  |  |  | $\mu$          |
| 5 | 1     |  |  |   |    |   |  |       |  |  |  |  |  |                |  |  |  | $\mu$          |
| 6 |       |  |  |   |    |   |  |       |  |  |  |  |  |                |  |  |  | $\mu$          |
| 7 |       |  |  |   |    |   |  |       |  |  |  |  |  |                |  |  |  |                |
| 8 |       |  |  |   |    | 1 |  |       |  |  |  |  |  |                |  |  |  |                |

The equations system (1) in system DERIVE looks like, resulted in the program of *CD/DERIVE/section95.dfv*, that will be used in other program.

Let us note some particular features of the equation system (1):

1. the existence of magnetic charges and currents is assumed,
2. instead of electric and magnetic currents we shall introduce scalar potentials and conductivities, not only electrical, but also magnetic ones.
3. it is assumed that the densities of electric and magnetic charges vary with time
4. Later these equations are extended also to physical systems containing microscopic bearers of electric and magnetic charges.

The introduction of electric and magnetic potentials allows considering the system of 8 Maxwell equations as 8 unknown functions – 6 intensities и 2 scalar differentials. The existing methods (as far as the author knows) assume that the charges densities and tee currents densities are known, and the unknown quantities are intensities. In this sense the Maxwell equations system is overdetermined

At present the author may present a realization of the method only for the case when (presumably) it is known that they comply with conditions (9.2.11).

Let us consider more closely the matrix  $\bar{R}_x$  in (9.2.15). To do this we shall first consider the vector (9.2.11) and in (9.2.13, 9.2.14) the item

$$\begin{aligned} \Phi_{Rx} &= \\ &= \iiint_{t,x,y,z} \left\{ \left( R_x \left( \frac{dq_x}{dx} \circ q_t \circ q_y \circ q_z \right) \right)^T \left( q_x \circ q_t \circ q_y \circ q_z \right) dt dx dz \right\} = \\ &= \iiint_{t,x,y,z} \left\{ \left( \frac{dq_x}{dx} \circ q_t \circ q_y \circ q_z \right)^T R_x^T \left( q_x \circ q_t \circ q_y \circ q_z \right) dt dx dz \right\} = \\ &= \sum_i \sum_k \iiint_{t,x,y,z} \left( \frac{dq_{xi}}{dx} q_{ti} q_{yi} q_{zi} R_{xki} q_{xk} q_{tk} q_{yk} q_{zk} \right) dt dx dz = \\ &= \sum_i \sum_k \oint_x \left( \frac{dq_{xi}}{dx} R_{ki} q_{xk} \left[ \left( \oint_t q_{ti} q_{tk} dt \right) \left( \oint_y q_{yi} q_{yk} dy \right) \left( \oint_z q_{zi} q_{zk} dz \right) \right] \right) \end{aligned}$$

Let us denote:

$$\hat{q}_{tik} = \left( \oint_t q_{ti} q_{tk} dt \right), \hat{q}_{xik} = \left( \oint_y q_{xi} q_{xk} dy \right),$$

$$\hat{q}_{yik} = \left( \oint_y q_{yi} q_{yk} dy \right), \hat{q}_{zik} = \left( \oint_z q_{zi} q_{zk} dz \right).$$
(2)

Then

$$\Phi_{Rx} = \sum_i \sum_k \oint_x \left( \frac{dq_{xi}}{dx} R_{xki} q_{xk} \hat{q}_{tik} \hat{q}_{yik} \hat{q}_{zik} \right) dx.$$

Let us consider the matrices

$$Q_t = \{ \hat{q}_{tik} \}, Q_x = \{ \hat{q}_{xik} \}$$

$$Q_y = \{ \hat{q}_{yik} \}, Q_z = \{ \hat{q}_{zik} \}$$
(3)

These matrices may be computed for fixed vector-functions  $q_t, q_x, q_y, q_z$ . Also

$$\Phi_{Rx} = \oint_x \left( \frac{dq_x}{dx} \left[ R_x \circ Q_t \circ Q_y \circ Q_z \right] q_x \right) dx$$

Thus,

$$\bar{R}_x = \left[ R_x \circ Q_t \circ Q_y \circ Q_z \right]$$
(4)

In the same manner we may consider the vector (9.2.12), the values

$$\hat{u}_{ti} = \left( \oint_t q_{ti} U_{ti} dt \right), \hat{u}_{xi} = \left( \oint_y q_{xi} U_{xi} dy \right),$$

$$\hat{u}_{yi} = \left( \oint_y q_{yi} U_{yi} dy \right), \hat{u}_{zi} = \left( \oint_z q_{zi} U_{zi} dz \right)$$
(5)

and vectors

$$u_t = \{ \hat{u}_{ti} \}, u_x = \{ \hat{u}_{xi} \}$$

$$u_y = \{ \hat{u}_{yi} \}, u_z = \{ \hat{u}_{zi} \}$$
(6)

Note, that in these vectors there are only two no-zero components :

$$\hat{u}_{m7} = \int_m \varphi \rho dm, \quad \hat{u}_{m8} = \int_m \phi \sigma dm, \quad m = (x, y, z, t) \quad (6a)$$

Then also

$$V_x = U_x \circ [u_t \circ u_y \circ u_z] \quad (7)$$

Similarly we may determine

$$\bar{R}_y = [R_y \circ Q_t \circ Q_x \circ Q_z] \quad (8)$$

$$V_y = U_y \circ [u_t \circ u_x \circ u_z] \quad (9)$$

$$\bar{R}_z = [R_z \circ Q_t \circ Q_x \circ Q_y] \quad (10)$$

$$V_z = U_z \circ [u_t \circ u_x \circ u_y] \quad (11)$$

$$\bar{R}_t = [R_t \circ Q_x \circ Q_y \circ Q_z] \quad (12)$$

$$V_t = U_t \circ [u_x \circ u_y \circ u_z] \quad (13)$$

Let us denote also

$$\hat{q}_{tik} = \left( \int_t \frac{q_{ti}}{dt} q_{tk} dt \right), \quad \hat{q}_{xik} = \left( \int_x \frac{q_{xi}}{dx} q_{xk} dx \right), \quad (14)$$

$$\hat{q}_{yik} = \left( \int_y \frac{q_{yi}}{dy} q_{yk} dy \right), \quad \hat{q}_{zik} = \left( \int_z \frac{q_{zi}}{dz} q_{zk} dz \right).$$

Consider matrices

$$\hat{Q}_t = \{ \hat{q}_{tik} \} \quad \hat{Q}_x = \{ \hat{q}_{xik} \} \quad (15)$$

$$\hat{Q}_y = \{ \hat{q}_{yik} \} \quad \hat{Q}_z = \{ \hat{q}_{zik} \}$$

Then, by the same reasoning, we may find the matrices

$$R_{tyz} = [R_t \circ \hat{Q}_t \circ Q_y \circ Q_z] \quad (16)$$

$$R_{ytz} = [R_y \circ \hat{Q}_y \circ Q_t \circ Q_z] \quad (17)$$

$$R_{zty} = [R_z \circ \hat{Q}_z \circ Q_t \circ Q_y] \quad (18)$$

Here the item  $S_x$  in formula (9.2.16) takes the form

$$S_x = R_{tyz} + R_{ytz} + R_{zty}. \quad (19)$$

The matrices named in the following table 1 may be determined in a similar way.

Table 1.

|   | t    | x    | y    | z    |  |
|---|------|------|------|------|--|
| t |      | Rtyz | Rtxz | Rtxy |  |
| x | Rxyz |      | Rxtz | Rxyt |  |
| y | Ryxz | Rytz |      | Rytx |  |
| z | Rzxy | Rzty | Rztx |      |  |
|   | St   | Sx   | Sy   | Sz   |  |

(20)

## 6. Example. Spatial Electromagnetic Wave

### 6.1. Computation of numbers (9.5.2), (9.5.14) and matrices (9.5.3), (9.5.15)

We shall now deal with the numbers (9.5.2), (9.5.14) and matrices (9.5.3), (9.5.15) for certain cases, in view of further use. Table 1 shows the vectors  $q_x, q_y, q_z, q_t$ , for which these numbers and matrices will be computed.

Table 1.

| № | 1            | 2              | 3                    | 4                      | 5                     | 6                      | 7             |
|---|--------------|----------------|----------------------|------------------------|-----------------------|------------------------|---------------|
|   | $q_x$        | $q_y$          | $q_x$                | $q_y$                  | $q_z$                 | $q_t$                  | $q_z$         |
| 1 | $e^{\chi x}$ | $e^{\gamma y}$ | $\text{Cos}(\chi x)$ | $\text{Sin}(\gamma y)$ | $\text{Cos}(\beta z)$ | $\text{Cos}(\omega t)$ | $e^{\beta z}$ |
| 2 | $e^{\chi x}$ | $e^{\gamma y}$ | $\text{Sin}(\chi x)$ | $\text{Cos}(\gamma y)$ | $\text{Cos}(\beta z)$ | $\text{Cos}(\omega t)$ | $e^{\beta z}$ |
| 3 | $e^{\chi x}$ | $e^{\gamma y}$ | $\text{Sin}(\chi x)$ | $\text{Sin}(\gamma y)$ | $\text{Sin}(\beta z)$ | $\text{Cos}(\omega t)$ | $e^{\beta z}$ |
| 4 | $e^{\chi x}$ | $e^{\gamma y}$ | $\text{Sin}(\chi x)$ | $\text{Cos}(\gamma y)$ | $\text{Sin}(\beta z)$ | $\text{Sin}(\omega t)$ | $e^{\beta z}$ |
| 5 | $e^{\chi x}$ | $e^{\gamma y}$ | $\text{Cos}(\chi x)$ | $\text{Sin}(\gamma y)$ | $\text{Sin}(\beta z)$ | $\text{Sin}(\omega t)$ | $e^{\beta z}$ |
| 6 | $e^{\chi x}$ | $e^{\gamma y}$ | $\text{Cos}(\chi x)$ | $\text{Cos}(\gamma y)$ | $\text{Cos}(\beta z)$ | $\text{Sin}(\omega t)$ | $e^{\beta z}$ |
| 7 | $e^{\chi x}$ | $e^{\gamma y}$ | $\text{Sin}(\chi x)$ | $\text{Sin}(\gamma y)$ | $\text{Cos}(\beta z)$ | $\text{Sin}(\omega t)$ | $e^{\beta z}$ |
| 8 | $e^{\chi x}$ | $e^{\gamma y}$ | $\text{Cos}(\chi x)$ | $\text{Cos}(\gamma y)$ | $\text{Sin}(\beta z)$ | $\text{Cos}(\omega t)$ | $e^{\beta z}$ |

First let us consider the matrix  $Q_x = \{\hat{q}_{xik}\}$  for the vector shown in the column 1 of Table 1. Evidently, all the numbers

$$\hat{q}_{xik} = \oint_x \left( e^{\chi x} \right) dx = a_x \tag{1}$$

and matrix

$$Q_x = a_x I, \tag{2}$$

Where  $I$  is a matrix made of unities. It is also evident that all the numbers

$$\hat{\hat{q}}_{xik} = \oint_x \frac{de^{\chi x}}{dx} e^{\chi x} dx = \chi a_x. \tag{3}$$

and the matrix



$$\hat{Q}_x = \chi a_x I, \tag{4}$$

Similarly, for the vector shown in column 2 of Table 1 we have:

$$Q_y = a_y I, \tag{5}$$

$$\hat{Q}_y = \gamma a_y I, \tag{6}$$

where

$$a_y = \oint_y (e^{\gamma y}) dy. \tag{7}$$

Similarly, for the vector written in the column 7 of Table 1, we have:

$$Q_z = a_z I, \tag{7a}$$

$$\hat{Q}_z = \beta a_z I, \tag{7b}$$

where

$$a_z = \oint_z (e^{\beta z}) dz, \tag{7c}$$

Now let us look at the vector shown in column 3 of Table 1. For this case the matrix  $Q_x = \{\hat{q}_{xik}\}$  is shown in the Table. 2, where

$$cc = \int_x \text{Cos}(\chi x) \text{Cos}(\chi x) dx, \quad ss = \int_x \text{Sin}(\chi x) \text{Sin}(\chi x) dx, \quad cs = \int_x \text{Sin}(\chi x) \text{Cos}(\chi x) dx,$$

and prefixes  $x, y, z, t$  mean that these are the positions of non-zero elements of the matrices  $R_x, R_y, R_z, R_t$  accordingly.

Table 2.

|   | $Q_x$ |      |      |      |      |      |      |      |
|---|-------|------|------|------|------|------|------|------|
| 1 | cc-t  | cs   | cs   | cs   | cc-z | ss-y | cs-x | cc   |
| 2 | cs    | ss-t | ss   | ss-z | cs   | cs-x | ss-y | cc   |
| 3 | cs    | ss   | ss-t | ss-y | cs-x | cs   | ss-z | cs   |
| 4 | cs    | ss-z | ss-y | ss-t | cs   | cs   | ss   | cs-x |
| 5 | cc-z  | cs   | cs-x | cs   | cc-t | cs   | cs   | cc-y |
| 6 | ss-y  | cs-x | cs   | cs   | cs   | cc-t | cs   | cc-z |
| 7 | cs-x  | ss-y | ss-z | ss   | cs   | cs   | ss   | cs   |
| 8 | cc    | cs   | cs   | cs-x | cc-y | cc-z | cs   | cc   |

On an interval dividable by value  $2\pi / \chi$ , we have:  $cc = ss$ . Let us denote  $b_x = cc = ss$ . From Table 2 it follows that component-wise multiplication of matrices  $R_y, R_z, R_t$  by  $Q_x$  is equivalent to these matrices multiplication by the number

$$b_x = \int_x \text{Cos}(\chi x) \text{Cos}(\chi x) dx. \tag{8}$$

So,

$$R_y \circ Q_x = b_x R_y, \quad R_z \circ Q_x = b_x R_z, \quad R_t \circ Q_x = b_x R_t. \tag{9}$$

Further, component-wise multiplication of matrix  $R_x$  by  $\hat{Q}_x$  is equivalent to multiplication:

$$R_x \circ \hat{Q}_x = \chi b_x R_x, \tag{10}$$

Similarly, for the vector shown in the column 4 of Table 1, we have

$$b_y = \int_y \text{Cos}(\gamma y) \text{Cos}(\gamma y) dy, \tag{11}$$

$$R_x \circ Q_y = b_y R_x, \quad R_z \circ Q_y = b_y R_z, \quad R_t \circ Q_y = b_y R_t, \tag{12}$$

$$R_y \circ \hat{Q}_y = \gamma b_y R_y. \tag{13}$$

Let us now consider the vector shown in the column 5 of Table 1. For this case the matrix  $Q_z = \{\hat{q}_{zik}\}$  is shown in the Table 3, where

$cc = \int_z \text{Cos}(\beta z) \text{Cos}(\beta z) dz$ ,  $ss = \int_z \text{Sin}(\beta z) \text{Sin}(\beta z) dz$ ,  $cs = \int_z \text{Cos}(\beta z) \text{Sin}(\beta z) dz$ ,  
and the prefixes  $x, y, z, t$  mean the same as in Table 2.

Table 3.

|   | $Q_z$ |      |      |      |      |      |      |      |
|---|-------|------|------|------|------|------|------|------|
| 1 | cc-t  | cc   | cs   | cs   | cs-z | cc-y | cc-x | cs   |
| 2 | cc    | cc-t | cs   | cs-z | cs   | cc-x | cc-y | cs   |
| 3 | cs    | cs   | ss-t | ss-y | ss-x | cs   | cs-z | ss   |
| 4 | cs    | cs-z | ss-y | ss-t | ss   | cs   | cs   | ss-x |
| 5 | cs-z  | cs   | ss-x | ss   | ss-t | cs   | cs   | ss-y |
| 6 | cc-y  | cc-x | cs   | cs   | cs   | cc-t | cc   | cs-z |
| 7 | cc-x  | cc-y | cs-z | cs   | cs   | cc   | cc   | cs   |
| 8 | cs    | cs   | ss   | ss-x | ss-y | cs-z | cs   | ss   |

As above for table. 2, let us denote  $a_z = cc = ss$  . From this Table 3 it follows that component-wise multiplication of matrices  $R_x, R_y, R_t$  by  $Q_z$  is equivalent to the multiplication of these matrices by the number

$$a_z = \int_z \text{Cos}(\beta z) \text{Cos}(\beta z) dz . \tag{14}$$

In this way,

$$R_x \circ Q_z = a_z R_x, \quad R_y \circ Q_z = a_z R_y, \quad R_t \circ Q_z = a_z R_t . \tag{15}$$

Further, component-wise multiplication of matrices  $R_z$  by  $\hat{Q}_z$  is equivalent to multiplication:

$$R_z \circ \hat{Q}_z = \beta a_z R_z . \tag{16}$$

Let us consider now the vector shown in the column 6 of Table 1. The matrix for this case  $Q_t = \{ \hat{q}_{tik} \}$  is shown in the Table 4, where  $cc = \int_t \text{Cos}(\omega t) \text{Cos}(\omega t) dt$ ,  $ss = \int_t \text{Sin}(\omega t) \text{Sin}(\omega t) dt$ ,  $cs = \int_t \text{Cos}(\omega t) \text{Sin}(\omega t) dt$ , and the prefixes  $x, y, z, t$  mean the same as in Table 2.

Table 4.

|   | $Q_t$ |      |      |      |      |      |      |      |
|---|-------|------|------|------|------|------|------|------|
| 1 | cc-t  | cc   | cc   | cs   | cs-z | cs-y | cs-x | cc   |
| 2 | cc    | cc-t | cc   | cs-z | cs   | cs-x | cs-y | cc   |
| 3 | cc    | cc   | cc-t | cs-y | cs-x | cs   | cs-z | cc   |
| 4 | cs    | cs-z | cs-y | ss-t | ss   | ss   | ss   | cs-x |
| 5 | cs-z  | cs   | cs-x | ss   | ss-t | ss   | ss   | cs-y |
| 6 | cs-y  | cs-x | cs   | ss   | ss   | ss-t | ss   | cs-z |
| 7 | cs-x  | cs-y | cs-z | ss   | ss   | ss   | ss   | cs   |
| 8 | cc    | cc   | cc   | cs-x | cs-y | cs-z | cs   | cc   |

From this table it follows that component-wise multiplication of the matrices  $R_x, R_y, R_z$  by  $Q_t$  is equivalent to multiplication of these matrices by the number

$$a_t = \int_t \text{Cos}(\omega t) \text{Sin}(\omega t) dt . \tag{17}$$

So,

$$R_x \circ Q_t = a_t R_x, \quad R_y \circ Q_t = a_t R_y, \quad R_z \circ Q_t = a_t R_z . \tag{18}$$

Further, component-wise multiplication of the matrix  $R_t$  by  $\hat{Q}_t$  is equivalent to multiplication

$$R_t \mathbf{o}\hat{Q}_t = a_t \omega R_t. \quad (19)$$

## 6.2. Setting of the Problem

Let

$$E_x = e_x \Psi_{cc} E_{xfx}(x) E_{xfy}(y), \quad (1)$$

$$E_y = e_y \Psi_{cc} E_{yfx}(x) E_{yfy}(y), \quad (2)$$

$$E_z = e_z \Psi_{cs} E_{zfx}(x) E_{zfy}(y), \quad (3)$$

$$H_x = h_x \Psi_{ss} H_{xfx}(x) H_{xfy}(y), \quad (4)$$

$$H_y = h_y \Psi_{ss} H_{yfx}(x) H_{yfy}(y), \quad (5)$$

$$H_z = h_z \Psi_{sc} H_{zfx}(x) H_{zfy}(y), \quad (6)$$

$$\varphi = \varphi_o \Psi_{sc} \varphi_{fx}(x) \varphi_{fy}(y), \quad (7)$$

$$\phi = \phi_o \Psi_{cs} \phi_{fx}(x) \phi_{fy}(y), \quad (8)$$

$$\rho = \rho_o \Psi_{cc} \Xi, \quad (9)$$

$$\sigma = \sigma_o \Psi_{ss} \Xi, \quad (10)$$

where

$$e_x, e_y, e_z, h_x, h_y, h_z, \varphi_o, \phi_o, \rho_o, \sigma_o \quad (11)$$

- real numbers,

$$\Psi_{sc} = (-\sin(\omega t))(-\cos(\beta z)), \quad (12a)$$

$$\Psi_{cs} = (-\cos(\omega t))\sin(\beta z), \quad (12b)$$

$$\Psi_{ss} = \sin(\omega t)(-\sin(\beta z)), \quad (12c)$$

$$\Psi_{cc} = \cos(\omega t)(-\cos(\beta z)), \quad (12d)$$

$$E_{xf}, H_{xf}, \varphi_{xf}, \phi_{xf}, E_{yf}, H_{yf}, \varphi_{yf}, \phi_{yf} \quad (14)$$

- unknown functions,

$$\Xi = \Xi(x, y) = \Xi_x(x) \Xi_y(y) \quad (15)$$

- a known function of a form that will be determined later

The problem is for certain coefficients  $\rho_o, \sigma_o$  from the set (11), determined by function  $\Xi$  (15) and known function  $\Psi$  of the form (12) using the Maxwell equations system (9.5.1) to find the functions (14) and unknown coefficients  $e_x, e_y, e_z, h_x, h_y, h_z, \varphi_o, \phi_o$  from the set (11).

Let us consider the vectors

$$\bar{q}^T = |e_x, e_y, e_z, h_x, h_y, h_z, \varphi_o, \phi_o|, \tag{29}$$

$$q^T = |E_x, E_y, E_z, H_x, H_y, H_z, \varphi, \phi|, \tag{30}$$

$$q = \bar{q} \circ q_x \circ q_y \circ q_z \circ q_t \tag{31}$$

- see also (9.3.11). The vectors included into the last formula, are determined in the Table 1.

Table 1.

| $q$             | $\bar{q}$   | $q_x$             | $q_y$             | $q_z$                  | $q_t$                   |
|-----------------|-------------|-------------------|-------------------|------------------------|-------------------------|
| $q_1 = E_x$     | $e_x$       | $E_{xfx}(x)$      | $E_{xfy}(y)$      | $\text{Cos}(\beta z)$  | $-\text{Cos}(\omega t)$ |
| $q_2 = E_y$     | $e_y$       | $E_{yfx}(x)$      | $E_{yfy}(y)$      | $\text{Cos}(\beta z)$  | $-\text{Cos}(\omega t)$ |
| $q_3 = E_z$     | $e_z$       | $E_{zfx}(x)$      | $E_{zfy}(y)$      | $-\text{Sin}(\beta z)$ | $-\text{Cos}(\omega t)$ |
| $q_4 = H_x$     | $h_x$       | $H_{xfx}(x)$      | $H_{xfy}(y)$      | $\text{Sin}(\beta z)$  | $-\text{Sin}(\omega t)$ |
| $q_5 = H_y$     | $h_y$       | $H_{yfx}(x)$      | $H_{yfy}(y)$      | $\text{Sin}(\beta z)$  | $-\text{Sin}(\omega t)$ |
| $q_6 = H_z$     | $h_z$       | $H_{zfx}(x)$      | $H_{zfy}(y)$      | $-\text{Cos}(\beta z)$ | $\text{Sin}(\omega t)$  |
| $q_7 = \varphi$ | $\varphi_o$ | $\varphi_{fx}(x)$ | $\varphi_{fy}(y)$ | $-\text{Cos}(\beta z)$ | $\text{Sin}(\omega t)$  |
| $q_8 = \phi$    | $\phi_o$    | $\varphi_{fx}(x)$ | $\varphi_{fy}(y)$ | $-\text{Sin}(\beta z)$ | $-\text{Cos}(\omega t)$ |

### 6.3. Computing the vectors (9.5.7, 9.5.9)

Let us consider the vectors

$$U^T = |0, 0, 0, 0, 0, 0, \rho, \sigma|, \tag{39}$$

$$\bar{U}^T = |0, 0, 0, 0, 0, 0, \rho_o, \sigma_o|, \tag{40}$$

$$U = \bar{U} \circ U_x \circ U_y \circ U_z \circ U_t \tag{41}$$

- see also (9.3.7). The vectors included into the last formula, are determined in the Table 2, where only 2 last (non-zero) components are shown.

Table 2.

|             | 7  | 8  |
|-------------|--|--|
| $U$         | $\rho$ - see (9.6.2.9)                   | $\sigma$ - see (9.6.2.10)                |
| $\bar{U}$   | $\rho_o$                                 | $\sigma_o$                               |
| $U_x$       | $\Xi_x(x)$                               | $\Xi_x(x)$                               |
| $U_y$       | $\Xi_y(y)$                               | $\Xi_y(y)$                               |
| $U_z$       | $\text{Cos}(\beta z)$                    | $\text{Sin}(\beta z)$                    |
| $U_t$       | $\text{Cos}(\omega t)$                   | $\text{Sin}(\omega t)$                   |
| $\hat{u}_x$ | $\oint_x \phi_{f_x}(x) \mathbf{E}(x) dx$ | $\oint_x \phi_{f_x}(x) \mathbf{E}(x) dx$ |
| $\hat{u}_y$ | $\oint_y \phi_{f_y}(y) \mathbf{E}(y) dy$ | $\oint_y \phi_{f_y}(y) \mathbf{E}(y) dy$ |
| $\hat{u}_z$ | $a_z$ - see. (9.6.1.14, 9.5.6a)          | $a_z$ - see. (9.6.1.14, 9.5.6a)          |
| $\hat{u}_t$ | $a_t$ - see (9.6.1.17)                   | $a_t$ - see (9.6.1.17)                   |
| $V_x$       | $a_t a_z \hat{u}_y \Xi(x)$               | $a_t a_z \hat{u}_y \Xi(x)$               |
| $V_y$       | $a_t a_z \hat{u}_x \Xi(y)$               | $a_t a_z \hat{u}_x \Xi(y)$               |

For known functions  $q$  and  $U$  the numbers (9.5.5) may be found. They are shown in Table 2. For their computation we shall use Table 1, where the numbers  $q_x, q_y, q_z, q_t$  are shown.

### 6.4. Iterations

Let us assume that on a certain iteration the functions  $q_t, q_y, q_z$  are fixed, and according to them (as was shown in Section 6.1) the matrices (9.5.3)  $Q_t, Q_y, Q_z$  and matrices (9.5.15)  $\hat{Q}_t, \hat{Q}_y, \hat{Q}_z$  were computed. From the formulas (9.5.4, 9.6.1.15, 9.6.1.18) it follows that:

$$\bar{R}_x = R_x \circ Q_t \circ Q_y \circ Q_z = a_z a_t R_x \circ Q_y. \tag{1}$$

From formulas (9.5.16, 9.6.1.15, 9.6.1.19) follows:

$$R_{tyz} = R_t \circ \hat{Q}_t \circ Q_y \circ Q_z = a_z a_t \omega R_t \circ Q_y. \quad (2)$$

From formulas (9.5.17, 9.6.1.15, 9.6.1.18) follows:

$$R_{ytz} = R_y \circ \hat{Q}_y \circ Q_t \circ Q_z = a_z a_t R_y \circ \hat{Q}_y. \quad (3)$$

From formulas (9.5.18, 9.6.1.16, 9.6.1.18) follows:

$$R_{zty} = R_z \circ \hat{Q}_z \circ Q_t \circ Q_y = \beta a_z a_t R_z \circ Q_y. \quad (4)$$

Then the matrix (9.5.19) is determined. Also on the same iteration the functions  $U_t$ ,  $U_y$ ,  $U_z$  are fixed, and according to them (as was shown in Section 6.3) the vector-function (9.5.7)  $V_x$  is determined. After this the vector-function  $q_x$  is determined from the equation (9.2.17)

$$S_x q_x + \bar{R}_x \left( \frac{dq_x}{dx} \right) + \bar{U} \circ V_x = 0. \quad (5)$$

And if on a certain iteration the functions  $q_t$ ,  $q_x$ ,  $q_z$  and  $U_t$ ,  $U_x$ ,  $U_z$  are fixed, then according to them the equation is similarly determined

$$S_y q_y + \bar{R}_y \left( \frac{dq_y}{dy} \right) + \bar{U} \circ V_y = 0. \quad (6)$$

### 6.5. Exponentially Distributed Charges Modeling

Let us consider first the case when the charges distribution function is of the form

$$\Xi = \Xi(x, y) = a e^{\chi|x| + \gamma|y|} \quad (1)$$

where  $\chi, \gamma$  are negative numbers, and  $a$  is the function's maximal value. We shall consider only the domain  $x \geq 0$ ,  $y \geq 0$ . Instead of function (1) we may consider the function

$$\Xi = \Xi(x, y) = a e^{\chi x + \gamma y} \quad (2)$$

We shall consider the vector-functions  $q_z$ ,  $q_t$ ,  $q_y$  as known in (6.2.1-8) and determined only in the 5, 6, 4 accordingly. Then component-wise multiplication by the matrices  $Q_y$ ,  $\hat{Q}_y$  is described by

formulas (9.1.5, 9.1.6), and the formulas (6.4.1-4) accordingly take the following form

$$\bar{R}_x = a_z a_t a_y R_x, \tag{3}$$

$$R_{tyz} = a_z a_t a_y \omega R_t, \tag{4}$$

$$R_{ytz} = a_z a_t a_y \gamma R_y, \tag{5}$$

$$R_{zty} = a_z a_t a_y \beta R_z. \tag{6}$$

Further by (2) and Tables 6.3.2 we find

$$\hat{u}_{y7} = \int_y \varphi_{fy}(y) \Xi(y) dy = \int_y \left( e^{\gamma y} \right) dy = a_y$$

and similarly

$$\hat{u}_{y8} = a_y,$$

and then

$$V_{x7} = \rho_0 a_t a_z a_y \Xi_x(x) = a_t a_z a_y \rho_0 e^{\lambda x}, \tag{7}$$

$$V_{x8} = \sigma_0 a_t a_z a_y \Xi_x(x) = a_t a_z a_y \sigma_0 e^{\lambda x}. \tag{8}$$

Substituting (3-8) in (9.5.19) and further substituting it in (9.6.4.6) and reducing by a common factor  $a_z a_t a_y$ , we get

$$\left\{ \begin{aligned} & (\gamma R_y + \beta R_z + \omega R_t) \eta_x + R_x \left( \frac{dq_x}{dx} \right) \\ & + [0, 0, 0, 0, 0, 0, \rho_0, \sigma_0]^T \cdot e^{\lambda x} \end{aligned} \right\} = 0. \tag{9}$$

Let us substitute in this equation the vector-function  $q_x$  in the form determined in the column 1. Then this equation will take the form

$$g e^{\lambda x} = 0, \tag{10}$$

where

$$g = \left\{ \begin{aligned} & (\gamma R_x + \gamma R_y + \beta R_z + \omega R_t) \\ & + [0, 0, 0, 0, 0, 0, \rho_0, \sigma_0]^T \end{aligned} \right\}. \tag{11}$$

i.e.  $g$  is a vector-function

$$g^T = [g_1, g_2, g_3, g_4, g_5, g_6, g_7, g_8] \tag{11a}$$

with components



|    |  |       |
|----|--|-------|
| 1. | $g_1 = (h_z \gamma - \beta h_y - \epsilon \omega e_x + \vartheta \phi_0 \chi)$ | (11b) |
| 2. | $g_2 = (\beta h_x + h_z \chi + \epsilon \omega e_y - \vartheta \phi_0 \gamma)$ |       |
| 3. | $g_3 = (h_y \chi - h_x \gamma + \omega \epsilon e_z + \beta \vartheta \phi_0)$ |       |
| 4. | $g_4 = (e_z \gamma + \beta e_y + \mu \omega h_x - \zeta \phi_0 \chi)$          |       |
| 5. | $g_5 = (\beta e_x + e_z \chi - \mu \omega h_y + \zeta \phi_0 \gamma)$          |       |
| 6. | $g_6 = (e_y \chi - e_x \gamma - \mu \omega h_z - \beta \zeta \phi_0)$          |       |
| 7. | $g_7 = (-e_x \chi - e_y \gamma - \beta e_z + \rho_0 / \epsilon)$               |       |
| 8. | $g_8 = (h_x \chi + h_y \gamma + \beta h_z - \sigma_0 / \mu)$                   |       |

Here the values  $\chi, \gamma, \beta, \omega, \rho_0, \sigma_0$  are known, and  $e_x, e_y, e_z, h_x, h_y, h_z, \phi_0, \phi_0$  - unknown. Evidently (10) is equivalent to equation

$$\mathbf{g} = \mathbf{0}. \quad (12)$$

The equation (12) or equations system (11c) may be solved in symbol form with respect to the unknown  $\bar{q} = [e_x, e_y, e_z, h_x, h_y, h_z, \phi_0, \phi_0]$  (for example, in system DERIVE – see the program of section965.dfw). This decision has a bulky appearance here again is not resulted. We shall notice only, that in this decision

$$\phi_0 \zeta = -\frac{\sigma_0 \omega}{\zeta (\beta^2 - \gamma^2 - \chi^2)} \quad (12a)$$

Thus, we have determined the form of vector-function  $\mathbf{q}_x$  and of the vector of coefficients  $\bar{q}$ . The numerical solution may be found with the aid of the function testMaxExpoX.

From (12a) the product  $\phi_0 \zeta = -\frac{\sigma_0 \omega}{a}$  may be found. The reader who doesn't accept the notion of magnetic resistance  $\zeta$  of the environment and of scalar magnetic potential  $\phi_0$ , may notice that for  $\zeta = \infty, \phi_0 = 0$  value of the product  $\zeta \phi_0$  is not determined and

may be assumed  $\phi_{0\zeta} = -\frac{\sigma_0\omega}{a}$  from (12a). Then another paradox

arises: the magnetic current exists in the absence of permeance and the scalar magnetic potential. Nevertheless, accepting in future the concept of magnetic resistance and scalar magnetic potential, we shall find the solutions of several problems possessing a physical meaning. (Note also that the substances with great magnetic permeability  $\mu$ , such as, for instance, soft iron, behave approximately as magnetic conductors [38].)

The solution (6.2.1-8) may be also presented in the following form

$$\left[ E_x, E_y, E_z, H_x, H_y, H_z, \varphi, \phi \right] = e^{\chi x + \gamma y} \cdot \bar{q} \cdot q_z \cdot q_t, \quad (13B)$$

where  $\bar{q}$ ,  $q_z$ ,  $q_t$  are specified in table 9.6.1.1. Consequently,

$$\left[ E_x, E_y, E_z, H_x, H_y, H_z, \varphi, \phi \right] = e^{\chi x + \gamma y} \cdot \bar{q} \cdot \left[ \Psi_{cc}, \Psi_{cc}, \Psi_{cs}, \Psi_{ss}, \Psi_{ss}, \Psi_{sc}, \Psi_{sc}, \Psi_{cs} \right] \quad (13a)$$

or

$$\Omega = \left[ E_x, E_y, E_z, H_x, H_y, H_z, \varphi, \phi \right] = e^{\chi x + \gamma y} \cdot \bar{q} \cdot q_z \cdot q_t, \quad (13B)$$

where  $\bar{q}$ ,  $q_z$ ,  $q_t$  are determined in the table 9.6.1.1. substituting this solution to the Maxwell equation system (9.5.1), we get

$$\mathbf{g} \circ \Lambda = \mathbf{0}, \quad (14)$$

where

" $\circ$ " denotes the operation of vectors component-wise multiplication.

$$\Lambda^T = e^{\chi x + \gamma y} \cdot \left[ \Psi_{sc}, \Psi_{sc}, \Psi_{ss}, \Psi_{cs}, \Psi_{cs}, \Psi_{cc}, \Psi_{cc}, \Psi_{ss} \right]. \quad (15)$$

It is evident that from the condition (14) follows condition (12), which is fulfilled. Therefore the solution (13) satisfies the equation system (9.5.1), which was to be proved.

The program `section965a.dfw` in system DERIVE carries out the specified transformations: makes substitution of functions (9.6.2.12a, b, c, d) and (9.6.5.13a, 9.6.5.2) in system of equations Максвелла (9.5.1), differentiates it, carries out reduction on the general multipliers (15) and calculates functions which appear equal to functions (11B).

## 6.6. Periodically Distributed Charges Modeling

Here we shall consider the charges with distribution density by the  $y$  – axis, of the form

$$\Xi(y) = ae^{\gamma y} \quad (1)$$

(as in previous section), but with distribution density by the  $x$  -axis, of the form

$$\Xi(x) = a \text{Sin}(\chi x). \quad (2)$$

As the formula (1) coincides with formula (9.6.5.2) for  $y$  -axis, so all the reasoning of the previous section may be repeated up to deducing the formulas (9.6.5.7, 9.6.5.8). In this case these formulas take the following form:

$$V_{x7} = \rho_o a_t a_z a_y \Xi_x(x) = a_t a_z a_y \rho_o \text{Sin}(\chi x), \quad (3)$$

$$V_{x8} = \sigma_o a_t a_z a_y \Xi_x(x) = a_t a_z a_y \sigma_o \text{Sin}(\chi x). \quad (4)$$

Then, similarly to formula (9.6.5.7) we get:

$$\left\{ \begin{array}{l} (\gamma R_y + \beta R_z + \omega R_t) \mathcal{I}_x + R_x \left( \frac{dq_x}{dx} \right) \\ + [0, 0, 0, 0, 0, 0, \rho_o, \sigma_o]^T \cdot \text{Sin}(\chi x) \end{array} \right\} = 0. \quad (5)$$

Using complex numbers, this equation may be written as:

$$\left\{ \begin{array}{l} ((\gamma R_y + \beta R_z + \omega R_t) + j\chi R_x) \mathcal{I}_x \\ + [0, 0, 0, 0, 0, 0, \rho_o, \sigma_o]^T \end{array} \right\} = 0. \quad (6)$$

The complex vector  $q_x$  may be computed as the solution of linear equation system (6) with complex coefficients with regard to the unknowns  $\bar{q} = [e_x, e_y, e_z, h_x, h_y, h_z, \phi_o, \phi_o]$  - see function `testMaxSinX`. So in this case also the form of vector-function  $q_x$  and coefficients vector  $\bar{q}$  are being determined.

### 6.7. Modeling with Charges Distributed According to Dirac Function

Here we shall deal with the charges with distribution density by the  $y$  -axis in the form (9.6.6.1) (as in previous section), but with distribution density by the  $x$  - axis of the form

$$\Xi(x) = a \lambda'(x). \quad (1)$$

where  $\lambda'$  is a Dirac function (see section 6.6). It is hard to imagine a real system with such distribution density, but still we shall consider such mathematical problem having in view that in future it will be modernized and "brought in to land". As the formula (9.6.6.1) is similar to formula

(9.6.5.2) for  $y$  -axis, all the reasoning of section 9.6.5 may be repeated here till formulas (9.6.5.7, 9.6.5.8). In this case these formulas will take the following form

$$V_{x7} = \rho_o a_t a_z a_y \Xi_x(x) = a_t a_z a_y \rho_o \lambda'(x), \tag{2}$$

$$V_{x8} = \sigma_o a_t a_z a_y \Xi_x(x) = a_t a_z a_y \sigma_o \lambda'(x). \tag{3}$$

Then, as for the formula (9.6.5.9) we get:

$$\left\{ \begin{aligned} & (\gamma R_y + \beta R_z + \omega R_t) \mathcal{I}_x + R_x \left( \frac{dq_x}{dx} \right) \\ & + [0,0,0,0,0,0, \rho_o, \sigma_o]^T \cdot \lambda'(x) \end{aligned} \right\} = 0. \tag{4}$$

Equation (4) is a differential equation with perturbations in the form of Dirac functions. A method for solving such equations was given in the section 6.6. Let us now use this method.

**Example 1.** Let us consider equation (4), setting the values of  $\omega, \gamma, \beta, \rho_o, \sigma_o$ . To solve the equation (4), we shall use the function `DEdirak`, mentioned in the Example 6.6.9c. The function `testMaxDiracX` contains addressing to this function and performs the computation for  $\omega = 2500, \gamma = 6000, \beta = 200, \rho_o = 5 \cdot 10^4, \sigma_o = 2 \cdot 10^5$ . The result is given in Figure 1, where the sought functions are shown. The main harmonics of these functions has circular frequency  $\gamma = 6000$  - in the first window a sinusoid graph is given as a dotted line for comparison.

Fig. 2 show the computation errors for each of eight Maxwell equations determined by formula

$$\varepsilon_m = (\gamma R_y + \beta R_z + \omega R_t) \mathcal{I}_x + R_x \left( \frac{dq_x}{dx} \right) \tag{5}$$

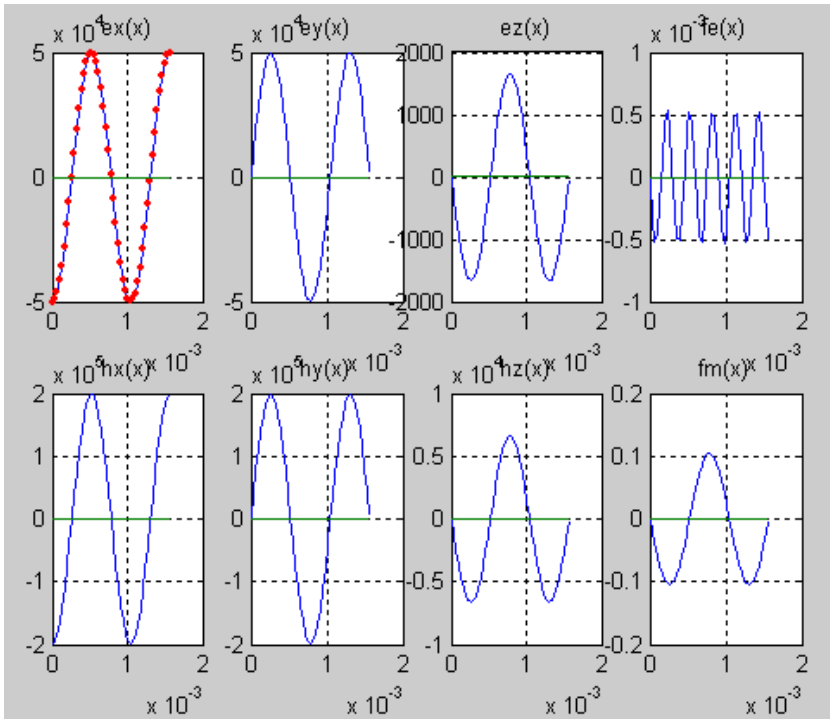

Fig. 1.

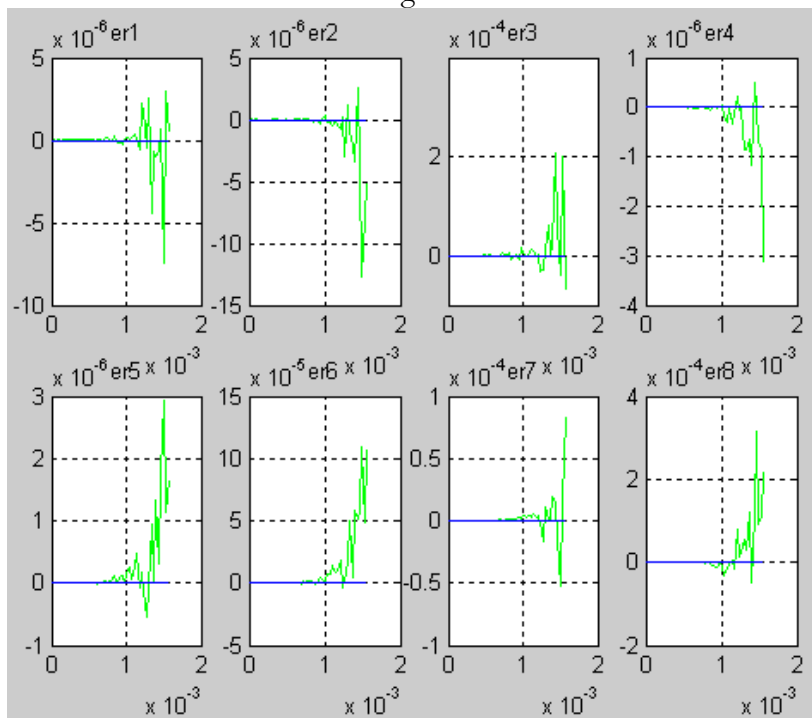

Fig. 2.

In the derivatives  $\frac{de_x}{dx}$ ,  $\frac{dh_x}{dx}$  in the solution for  $x = 0$  there appear Dirac functions, which is explained in 6.9a – see formula (A). They have the following value

$$\frac{de_x}{dx} \lambda' = -\frac{\rho_o}{\varepsilon}, \quad \frac{dh_x}{dx} \lambda' = -\frac{\sigma_o}{\mu}. \quad (6)$$

Besides, for  $x = 0$  the functions  $E_x$ ,  $H_x$  have non-zero values – there is a jump in these functions values, namely

$$E_x(x = 0, y, z, t) = -\frac{\rho(y, z, t)}{\varepsilon}, \quad (7)$$

$$H_x(x = 0, y, z, t) = -\frac{\sigma(y, z, t)}{\mu}.$$

These remarks must be held in mind in future in the process of solving Maxwell equations system with Dirac functions.

So, in this case the presented method also allows to determine the form of vector-function  $q_x$  and vector of coefficients  $\bar{q}$ .

**Example 2.** In the Example 1 it was assumed that the electric conductivities  $\mathcal{G}_x, \mathcal{G}_y, \mathcal{G}_z$  and magnetic permeances  $\zeta_x, \zeta_y, \zeta_z$  had different values along different axes. In this Example we shall assume them to be equal. The result proves to be more symmetrical – see Figure3, built by the function `testMaxDiracXnow`. The periodical functions have circular frequency  $\chi = 6003$ .

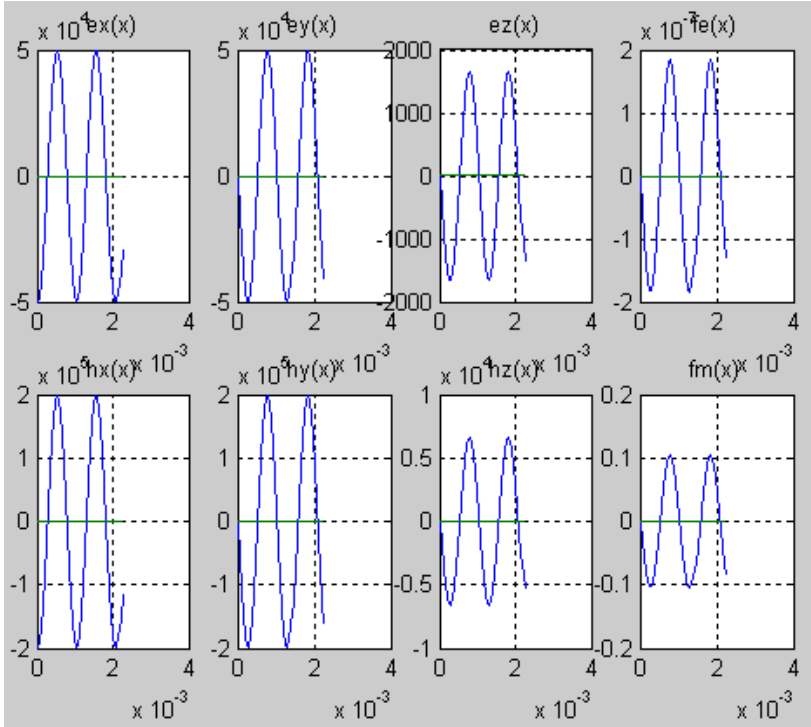

Fig. 3.

Table 1.

| $q$             | $\bar{q}$   | $q_x$                 | $q_y$          | $q_z$                  | $q_t$                   |
|-----------------|-------------|-----------------------|----------------|------------------------|-------------------------|
| $q_1 = E_x$     | $e_x$       | $-\text{Cos}(\chi x)$ | $e^{\gamma y}$ | $\text{Cos}(\beta z)$  | $-\text{Cos}(\omega t)$ |
| $q_2 = E_y$     | $e_y$       | $-\text{Sin}(\chi x)$ | $e^{\gamma y}$ | $\text{Cos}(\beta z)$  | $-\text{Cos}(\omega t)$ |
| $q_3 = E_z$     | $e_z$       | $-\text{Sin}(\chi x)$ | $e^{\gamma y}$ | $-\text{Sin}(\beta z)$ | $-\text{Cos}(\omega t)$ |
| $q_4 = H_x$     | $h_x$       | $-\text{Cos}(\chi x)$ | $e^{\gamma y}$ | $\text{Sin}(\beta z)$  | $-\text{Sin}(\omega t)$ |
| $q_5 = H_y$     | $h_y$       | $-\text{Sin}(\chi x)$ | $e^{\gamma y}$ | $\text{Sin}(\beta z)$  | $-\text{Sin}(\omega t)$ |
| $q_6 = H_z$     | $h_z$       | $-\text{Sin}(\chi x)$ | $e^{\gamma y}$ | $-\text{Cos}(\beta z)$ | $\text{Sin}(\omega t)$  |
| $q_7 = \varphi$ | $\varphi_0$ | $-\text{Sin}(\chi x)$ | $e^{\gamma y}$ | $-\text{Cos}(\beta z)$ | $\text{Sin}(\omega t)$  |
| $q_8 = \phi$    | $\phi_0$    | $-\text{Sin}(\chi x)$ | $e^{\gamma y}$ | $-\text{Sin}(\beta z)$ | $-\text{Cos}(\omega t)$ |

So, when solving the equation (4) in the case of equal electroconductivities  $\varrho_x, \varrho_y, \varrho_z$  and magnetoconductivities  $\varsigma_x, \varsigma_y, \varsigma_z$  the functions  $q_x$  assume the form shown in Table 1 (in it  $q, \bar{q}, q_z, q_t$  are taken from Table 6.2.1).

Note the important difference between this problem and problems considered in Sections 9.6.5 and 9.6.6. There the intensity functions and potentials  $q_x, q_y$  assumed the same form as the given charge functions (9.6.2.15). So if this function was an exponent (9.6.5.2), then the functions  $q_x, q_y$  had the same form - see. (9.6.5.13). And if this function was a sinusoid (9.6.6.2), then the function  $q_x$  assumed the form of sinusoid. In this section this function is a Dirac function (1). But at the same time the functions  $q_x$  were sinusoids. Besides, (as we

already mentioned) the derivatives  $\frac{de_x}{dx}, \frac{dh_x}{dx}$  from two of these functions assumed the form of Dirac functions – see. (6). Thus, the charges that change as Dirac function along the axis  $ox$ , excite the same electromagnetic waves, as the charges that change periodically along the same axis  $ox$ . But, besides, on the plane  $zoy$  these (changing as Dirac function along the axis  $ox$ ) charges create a jump of intensities  $e_x, h_x$  in the point  $x = 0$ , which is determined by formula (6). From this it follows that in this case the Dirac functions (9.5.1.7, 8) are split into couples of equations, taking the following form:

for  $x = 0$

$$E_x(x = 0, y, z, t) = -\frac{\rho(y, z, t)}{\varepsilon}, \quad (8)$$

$$H_x(x = 0, y, z, t) = -\frac{\sigma(y, z, t)}{\mu}, \quad (9)$$

for  $x > 0$

$$-\frac{dE_x}{dx} - \frac{dE_y}{dy} - \frac{dE_z}{dz} = 0, \quad (10)$$



$$\frac{dH_x}{dx} + \frac{dH_y}{dy} + \frac{dH_z}{dz} = 0. \quad (11)$$

Thus, when solving the equation (4) in the case of equal electric conductivities  $\mathcal{G}_x, \mathcal{G}_y, \mathcal{G}_z$  and magnetic permeances  $\zeta_x, \zeta_y, \zeta_z$  the functions  $q_x$  assume the form given in the Table 1.

Substituting these functions to the Maxwell equation (9.5.1.1), we find:

$$\left( \begin{array}{l} - (h_z \gamma + \beta h_y) \text{Sin}(\chi x) \\ + (\epsilon \omega \epsilon_x - \mathcal{G} \phi_0 \chi) \text{Cos}(\chi x) \end{array} \right) e^{\gamma y} \text{Sin}(\omega t) \text{Cos}(\beta z) = 0.$$

It is easy to see that this equation falls into two independent equations with respect to the components of electric and magnetic fields.

Аналогичное замечание можно сделать относительно всех уравнений в системе уравнений (9.5.1) с учетом (7-10).

The program section967.dfw in system DERIVE carries out the specified transformations: makes substitution of functions from Table 6.2.1 in system of equations Максвелла (9.5.1) and differentiates it. Thus it is possible to be convinced, that the same may be said about all the equations in the equations system (9.5.1). Thus it follows that under the conditions of this problem the electric waves may originate in the absence of magnetic waves and vice versa.

### 6.7a. Magnetic wave in simulation with charges distributed according to Dirac function

Let us consider the Maxwell equations system (9.5.1) for the functions presented in the Table 9.6.7.1, under the condition that only magnetic charges are present. In this case only a magnetic field will arise, and the equations system (9.5.1) will assume the following form:

$$(h_z \gamma + \beta h_y) = 0, \quad (1)$$

$$(h_x \beta + \chi h_z) = 0, \quad (2)$$

$$(\chi h_y - \gamma h_x) = 0, \quad (3)$$

$$\mu \omega h_x - \zeta \chi \phi_0 = 0, \quad (4)$$

$$\mu \omega h_y - \zeta \gamma \phi_0 = 0, \quad (5)$$

$$\mu \omega h_z + \zeta \beta \phi_0 = 0, \quad (6)$$

$$\chi h_x - \gamma h_y - \beta h_z - \sigma_o / \mu = 0. \quad (8)$$

In these equations the multipliers  $Sin(\chi x)e^{jy}Sin(\omega t)Cos(\beta z)$  are not shown for brevity sake.

From (9.6.7.8) it follows that

$$h_x = \sigma_o / \mu. \quad (9)$$

From (1, 2, 3) we find:

$$h_z = -h_y \beta / \gamma, \quad (11)$$

$$h_z = -h_x \beta / \chi, \quad (12)$$

$$h_y = h_x \gamma / \chi. \quad (13)$$

From (4, 5, 6) we find:

$$\zeta \phi_o = h_x \mu \omega / \chi = h_y \mu \omega / \gamma = -h_z \mu \omega / \beta. \quad (14)$$

From (8, 11, 12, 13) for  $x > 0$  we get:

$$\left( \chi - \frac{\gamma^2}{\chi} - \frac{\beta^2}{\chi} \right) \cdot h_x = 0 \quad (15)$$

or

$$\chi = \sqrt{(\gamma^2 + \beta^2)}. \quad (17)$$

Thus, for the given  $\sigma_o, \gamma, \beta, \omega$  according to (9, 12, 13, 14, 17) all the parameters of magnetic wave  $h_x, h_z, h_y, \zeta \phi_o, \chi$  may be accordingly found

### 6.7B. Electric wave in simulation with charges distributed according to Dirac function

Let us consider the Maxwell equations system (9.5.1) for the functions presented in the Table 9.6.7.1, under the condition that only electric charges are present. In this case only a electric field will arise, and the equations system (9.5.1) will assume the following form:

$$(e_z \gamma + \beta e_y) = 0. \quad (1)$$

$$(e_x \beta + \chi e_z) = 0, \quad (2)$$

$$(\chi e_y - \gamma e_x) = 0, \quad (3)$$

$$\mu \omega e_x - \theta \chi \phi_o = 0, \quad (4)$$

$$\mu \omega e_y - \theta \gamma \phi_o = 0, \quad (5)$$

$$\mu\omega e_z + \theta\beta\varphi_0 = 0, \quad (6)$$

$$\chi e_x - \gamma e_y - \beta e_z - \rho_0/\varepsilon = 0. \quad (8)$$

From (9.6.7.9) it follows that

$$e_x = \rho_0/\varepsilon. \quad (9)$$

Also, as well as in section 9.6.7a, we find:

$$e_z = -e_x \beta/\chi, \quad (10)$$

$$e_y = e_x \gamma/\chi. \quad (11)$$

$$\mathcal{G}\varphi_0 = e_x \varepsilon\omega/\chi = e_y \varepsilon\omega/\gamma = -e_z \varepsilon\omega/\beta. \quad (12)$$

$$\chi \approx \sqrt{\left(\gamma^2 + \beta^2\right)}. \quad (13)$$

Thus, for the given  $\rho_0, \gamma, \beta, \omega$  according to (9-13) all the parameters of magnetic wave  $h_x, h_z, h_y, \zeta, \phi_0, \chi$  may be accordingly found

### 6.8. Modeling with Charges Distributed According to Step Function

Here we shall deal with charges with distribution density by  $y$ -axis of the form (9.6.6.1), but distribution density by the  $x$ -axis of the form

$$\Xi(x) = a\lambda(x). \quad (1)$$

where  $\lambda$  – unit step (see section 6.4). As formula (9.6.6.1) is similar to formula (9.6.5.2) for  $y$ -axis, all the reasoning of section 9.6.5 may be repeated here, up to getting formulas (9.6.5.7, 9.6.5.8). In this case these formulas assume the following form

$$V_{x7} = \rho_0 a_t a_z a_y \Xi_x(x) = a_t a_z a_y \rho_0 \lambda(x), \quad (2)$$

$$V_{x8} = \sigma_0 a_t a_z a_y \Xi_x(x) = a_t a_z a_y \sigma_0 \lambda(x). \quad (3)$$

Then, similarly to formula (9.6.5.7) we shall get:

$$\left\{ \begin{array}{l} \left( \gamma R_y + \beta R_z + \omega R_t \right) \mathcal{H}_x + R_x \left( \frac{dq_x}{dx} \right) \\ + \left[ 0, 0, 0, 0, 0, 0, \rho_0, \sigma_0 \right]^T \cdot \lambda(x) \end{array} \right\} = 0. \quad (4)$$

Equation (4) is a differential equation with perturbations described by step functions. The method for solving such equations was given in section 6.4. Now we shall use this method.

**Example 1.** Let us consider equation (4), setting the values  $\omega, \gamma, \beta, \rho_o, \sigma_o$ . To solve equation (4) we shall use the function `DEjumpRC`, mentioned in Example 6.4.8. Function `testMaxJumpX` contains addressing `DEjumpRC` and performs the computation with

$$\omega = 2500, \quad \gamma = 6000, \quad \beta = 200, \quad \rho_o = 5 \cdot 10^4, \quad \sigma_o = 2 \cdot 10^5.$$

The result is given in Figure 1, where the sought functions are shown. The main harmonics of these functions has circular frequency  $\gamma = 6000$  - in the first window a sinusoid graph is given as a dotted line for comparison. Figure 2 shows the computation errors for each of the eight Maxwell equations defined by the formula (9.6.7.5)

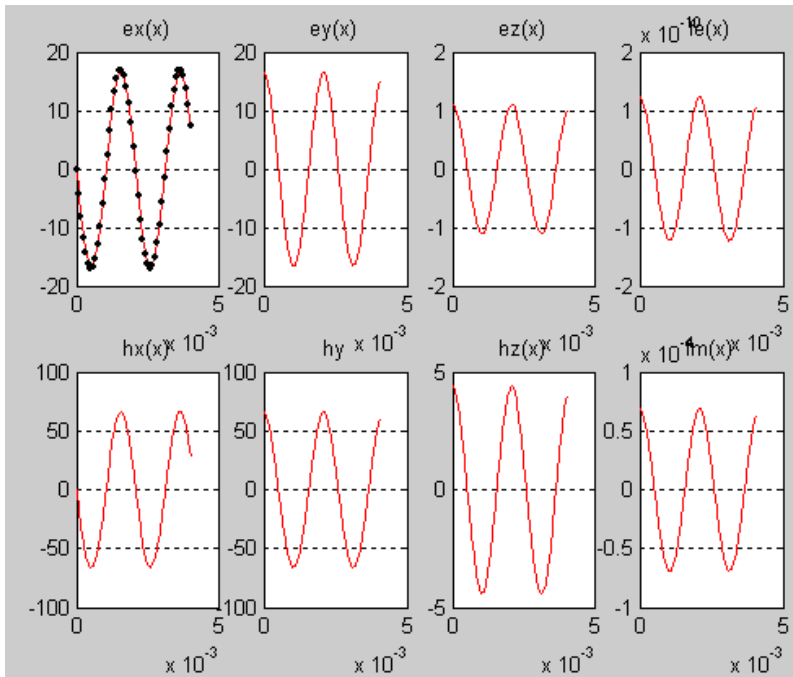

Fig. 1.

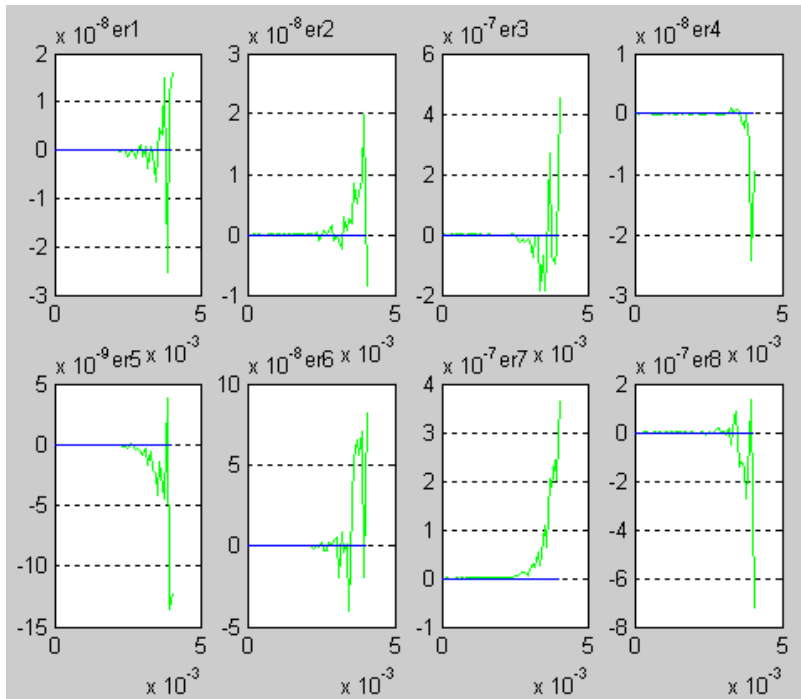

Fig. 2.

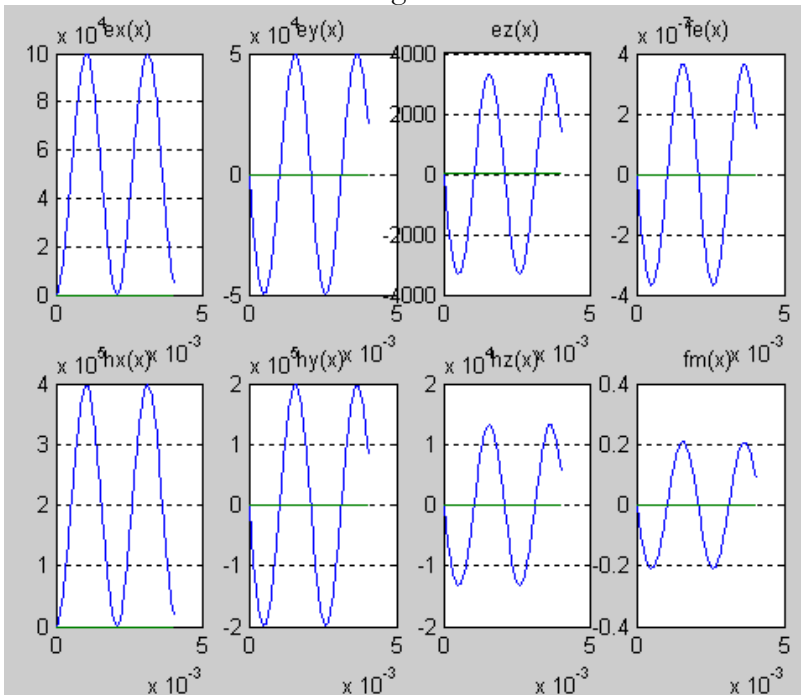

Fig. 3.

Step functions appear in the derivatives of the sought function with respect to  $y$  which was explained in Example 6.4.7. As the result the nodes of main harmonics for these derivatives are displaced from the origin – see Figure 3, where these graphs are shown.

So in this case also the presented method enables to determine the form of vector-function  $q_x$  and the coefficients  $\bar{q}$ .

### 6.9. Modeling with Charges Distributed Non-uniformly

Let us now consider the case when the charges distribution is described by multistep trapezium (or, for instance, by square pulse). In this case we ought to use the method described in section 6.5. The fig. 1 shows the result of computation, similarly to Example 9.6.8.1, but for trapezium charges distribution. (see the function `testMaxTrapX`). One can see that the electromagnetic fields amplitudes depend significantly from the type of charges distribution.

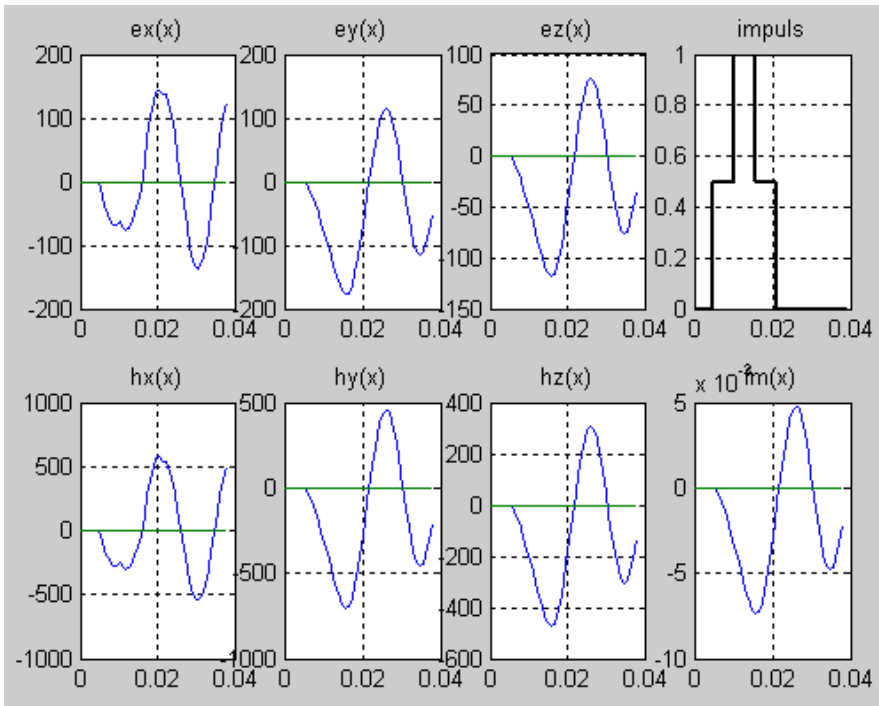

Fig. 1.

For example, if all the other conditions are the same, the amplitude  $h_z$  is equal to

60 for step function distribution

500 for three-step trapezium distribution,

50000 for distribution described by Dirac function (see accordingly 9.6.8.1, 9.6.9.1, 9.6.7.1).

Trapezium distribution of charges may be considered an approximation of exponential distribution, examined in section 9.6.5.

### 6.10. Discussion

In general, the scheme of the method use is as follows:

- 1) An assumption about electromagnetic waves form as a function of three coordinates (for instance,  $y, z, t$ ) is made.
- 2) Matrices (9.5.3), (9.5.15) and vectors (9.5.7, 9.5.9) based on this assumption are computed.
- 3) The form of electromagnetic waves as a function of the fourth coordinate (for instance,  $x$ ), with the use of the known matrices and vectors is determined. If the elements of the named matrices (9.5.3), (9.5.15) are not equal (by absolute value), then we get damped oscillation (in space and/or in time). It is significant that the algorithms of section 6, applied to the determination of the functions types (in the case when they are not smooth functions), enable us to get an analytical presentation of these functions (in the form of power series). In the previous examples the same way was used to derive the frequency of the main harmonics of the sought functions.
- 4) The obtained functions are substituted to the Maxwell Equations system and the parameters of these functions  $\epsilon_{\text{тнх}}$  (such as the amplitudes and the damping coefficients) are computed. In the case when they are not smooth, the parameters are determined (using algorithms of section 6) simultaneously with the functions form determination.
- 5) When the form of the electromagnetic waves as a function of coordinate  $x$  is obtained, the assumptions of p.1 and so on, may be specified by the same method.

The method is applicable also in the case of heterogeneous space (see section 9.4.5).

## 7. Example. Superpositions of Electromagnetic Waves

In the cases discussed above the electromagnetic fields intensity functions may be presented in the form (9.2.11). Now we shall discuss the case when the electromagnetic fields intensity functions may be presented as a superposition of the functions (9.2.11).

### 1. Electromagnetic oscillations with exponentially distributed charges. Case 1.

Let us return to the problem discussed in the section 9.6.5 where the charges density distribution functions (9.6.2.9, 9.6.2.10) with respect to arguments  $x, y, z, t$ , are known:

$$\rho = \rho_o \Psi_{cc} e^{\chi x + \gamma y}, \quad (1)$$

$$\sigma = \sigma_o \Psi_{ss} e^{\chi x + \gamma y}. \quad (2)$$

Table 1.

| $q$             | $\bar{q}$   | Variants    |             |          |
|-----------------|-------------|-------------|-------------|----------|
|                 |             | 1           | 2           | 3        |
| $q_1 = E_x$     | $e_x$       | $\Psi_{cc}$ | $\Psi_{ss}$ | $\Omega$ |
| $q_2 = E_y$     | $e_y$       | $\Psi_{cc}$ | $\Psi_{ss}$ | $\Omega$ |
| $q_3 = E_z$     | $e_z$       | $\Psi_{cs}$ | $\Psi_{sc}$ | $\Psi$   |
| $q_4 = H_x$     | $h_x$       | $\Psi_{ss}$ | $\Psi_{cc}$ | $\Omega$ |
| $q_5 = H_y$     | $h_y$       | $\Psi_{ss}$ | $\Psi_{cc}$ | $\Omega$ |
| $q_6 = H_z$     | $h_z$       | $\Psi_{sc}$ | $\Psi_{cs}$ | $\Psi$   |
| $q_7 = \varphi$ | $\varphi_o$ | $\Psi_{sc}$ | $\Psi_{cs}$ | $\Psi$   |
| $q_8 = \phi$    | $\phi_o$    | $\Psi_{cs}$ | $\Psi_{sc}$ | $\Psi$   |
| $\rho$          | $\rho_o$    | $\Psi_{cc}$ | $\Psi_{ss}$ | $\Omega$ |
| $\sigma$        | $\sigma_o$  | $\Psi_{ss}$ | $\Psi_{cc}$ | $\Omega$ |



Here we, as distinct from (9.6.2.12), shall define the functions  $\Psi$  in the form

$$\Psi_{cc} = \text{Cos}(\omega t)\text{Cos}(\beta z), \tag{2a}$$

$$\Psi_{ss} = -\text{Sin}(\omega t)\text{Sin}(\beta z), \tag{2b}$$

$$\Psi_{cs} = \text{Cos}(\omega t)\text{Sin}(\beta z), \tag{2c}$$

$$\Psi_{sc} = \text{Sin}(\omega t)\text{Cos}(\beta z), \tag{2d}$$

The intensity and potentials functions from arguments  $x, y, z, t$  are defined by (9.6.13a), i.e.

$$\begin{aligned} & \left[ E_x, E_y, E_z, H_x, H_y, H_z, \varphi, \phi \right] = \\ & e^{\chi x + \gamma y} \cdot \bar{q} \cdot \begin{bmatrix} \Psi_{cc}, \Psi_{cc}, \Psi_{cs}, \Psi_{ss}, \\ \Psi_{ss}, \Psi_{sc}, \Psi_{sc}, \Psi_{cs} \end{bmatrix}, \end{aligned} \tag{3}$$

where real numbers

$$\bar{q} = \left[ e_x, e_y, e_z, h_x, h_y, h_z, \varphi_0, \phi_0 \right]. \tag{4}$$

For clearness sake in the Table. 1 the functions  $\Psi$ , included in (1, 2, 3), are enumerated– see version 1.

To show what is the form of Maxwell equations (9.5.1) in this case, let us consider a vector-function (9.6.5.11a) from  $\chi, \gamma, \beta, \omega, \rho_0, \sigma_0, e_x, e_y, e_z, h_x, h_y, h_z, \varphi_0, \phi_0$ , i.e.,

$$\mathbf{g}^T = \left[ g_1, g_2, g_3, g_4, g_5, g_6, g_7, g_8 \right], \tag{5}$$

Here we, unlike (9.6.5.11b) shall define the functions (5) in the form

|    |   |      |
|----|---|------|
| 1. | $g_1 = (h_z \gamma + \beta h_y + \varepsilon \omega e_x + \vartheta \varphi_0 \chi)$  | (5a) |
| 2. | $g_2 = (-\beta h_x - h_z \chi + \varepsilon \omega e_y + \vartheta \varphi_0 \gamma)$ |      |
| 3. | $g_3 = (h_y \chi - h_x \gamma - \omega \varepsilon e_z + \beta \vartheta \varphi_0)$  |      |
| 4. | $g_4 = (e_z \gamma + \beta e_y - \mu \omega h_x - \zeta \phi_0 \chi)$                 |      |
| 5. | $g_5 = (-\beta e_x - e_z \chi - \mu \omega h_y - \zeta \phi_0 \gamma)$                |      |
| 6. | $g_6 = (e_y \chi - e_x \gamma + \mu \omega h_z - \beta \zeta \phi_0)$                 |      |
| 7. | $g_7 = (-e_x \chi - e_y \gamma - \beta e_z + \rho_0 / \varepsilon)$                   |      |
| 8. | $g_8 = (h_x \chi + h_y \gamma + \beta h_z - \sigma_0 / \mu)$                          |      |

Turning to the remark at the end of Section 9.6.1, we must note that in this case the matrices  $R_x, R_y, R_z, R_t$  differ from the matrices given in Section 9.5, by the signs of some elements. The differing elements are denoted below by darkening.

|   | $R_x$ |   |  |  |   |   |            | $R_y$ |  |  |    |  |    |             |  |           |
|---|-------|---|--|--|---|---|------------|-------|--|--|----|--|----|-------------|--|-----------|
| 1 |       |   |  |  |   |   | $\theta_x$ |       |  |  |    |  | 1  |             |  |           |
| 2 |       |   |  |  |   | 1 |            |       |  |  |    |  |    | $-\theta_y$ |  |           |
| 3 |       |   |  |  | 1 |   |            |       |  |  |    |  | -1 |             |  |           |
| 4 |       |   |  |  |   |   | $-\zeta_x$ |       |  |  | 1  |  |    |             |  |           |
| 5 |       |   |  |  | 1 |   |            |       |  |  |    |  |    |             |  | $\zeta_y$ |
| 6 |       | 1 |  |  |   |   |            | -1    |  |  |    |  |    |             |  |           |
| 7 | -1    |   |  |  |   |   |            |       |  |  | -1 |  |    |             |  |           |
| 8 |       |   |  |  | 1 |   |            |       |  |  |    |  | 1  |             |  |           |

|   | $R_z$ |  |  |  |    |   |            | $R_t$         |                |  |               |        |       |  |        |  |
|---|-------|--|--|--|----|---|------------|---------------|----------------|--|---------------|--------|-------|--|--------|--|
| 1 |       |  |  |  | 1  |   |            | $\varepsilon$ |                |  |               |        |       |  |        |  |
| 2 |       |  |  |  | -1 |   |            |               | $-\varepsilon$ |  |               |        |       |  |        |  |
| 3 |       |  |  |  |    |   | $\theta_z$ |               |                |  | $\varepsilon$ |        |       |  |        |  |
| 4 |       |  |  |  |    |   |            |               |                |  |               | $-\mu$ |       |  |        |  |
| 5 | -1    |  |  |  |    |   |            |               |                |  |               |        | $\mu$ |  |        |  |
| 6 |       |  |  |  |    |   | $-\zeta_z$ |               |                |  |               |        |       |  | $-\mu$ |  |
| 7 |       |  |  |  |    |   |            |               |                |  |               |        |       |  |        |  |
| 8 |       |  |  |  |    | 1 |            |               |                |  |               |        |       |  |        |  |

We shall define similarly to (9.6.5.15) also the vector -function

$$\Lambda^T = e^{\chi x + \gamma y} \cdot [\Psi_{sc}, \Psi_{sc}, \Psi_{ss}, \Psi_{cs}, \Psi_{cs}, \Psi_{cc}, \Psi_{cc}, \Psi_{ss}]. \quad (6)$$

By substituting the functions (1, 2, 3) to the Maxwell equations system (9.5.1) we may see that

$$g \circ \Lambda = 0, \quad (7)$$

where "o" the operation of component wise multiplication of vectors. After reducing each equation from (7) by multiplier (6) this equation system will be transformed into equation system

$$g = 0. \quad (8)$$

The program section971a.dfw in the DERIVE system performs the indicated processing: substitutes the functions (9.7.1.2a, b, c, d; 3) and (9.6.5.2) into the Maxwell equations system (9.5.1), differentiates this

system, cancels the common factors (6) and computes the functions  $\mathbf{g} = \mathbf{0}$ , which turn out to be equal to functions (5a).

For the given parameters  $\varepsilon, \mu, \mathcal{G}, \zeta$ , characterizing the domain of waves and currents distribution, and given  $\chi, \gamma, \beta, \omega, \rho_0, \sigma_0$ , the numbers  $e_x, e_y, e_z, h_x, h_y, h_z, \varphi_0, \phi_0$  may be found as the solution of linear equation system (8) or, which is the same, equations system (5a).

Thus, if the charges densities are distributed according to functions (1, 2) with known  $\chi, \gamma, \beta, \omega, \rho_0, \sigma_0$ , then there emerge electromagnetic fields and scalar potentials, enumerated in the table 1 (version 1), and the parameters  $e_x, e_y, e_z, h_x, h_y, h_z, \varphi_0, \phi_0$  are functions  $\chi, \gamma, \beta, \omega, \rho_0, \sigma_0$ , determined by solving the linear equations system (5a).

## 2. Electromagnetic oscillations with exponentially distributed charges. Case 2.

Let us assume now that, unlike (9.8.1.2, 9.8.1.2),

$$\rho = \rho_0 \Psi_{ss} e^{\chi x + \gamma y}, \quad (1)$$

$$\sigma = \sigma_0 \Psi_{cc} e^{\chi x + \gamma y}. \quad (2)$$

Then by analogy with the above said we may find the functions  $\Psi$ , taking the values enumerated in the Table 1 (version 2). The parameters  $e_x, e_y, e_z, h_x, h_y, h_z, \varphi_0, \phi_0$  are functions of  $\chi, \gamma, \beta, \omega, \rho_0, \sigma_0$ , determined also from the linear equation system (1.5a). But in this case this equations system follows from the equations system (1.7), where, unlike (1.6), the vector

$$\Lambda^T = e^{\chi x + \gamma y} \cdot [\Psi_{cs}, \Psi_{cs}, \Psi_{cc}, \Psi_{sc}, \Psi_{sc}, \Psi_{ss}, \Psi_{ss}, \Psi_{cc}]. \quad (3)$$

## 3. Electromagnetic oscillations with linear movement of exponentially distributed charges.

Let us denote

$$\Omega = \text{Cos}(\omega t + \beta z), \quad (1)$$

$$\Psi = \text{Sin}(\omega t + \beta z), \quad (2)$$

Since

$$\text{Cos}(\omega t + \beta z) = \text{Cos}(\omega t) \text{Cos}(\beta z) - \text{Sin}(\omega t) \text{Sin}(\beta z),$$

$$\sin(\omega t + \beta z) = \sin(\omega t)\cos(\beta z) + \cos(\omega t)\sin(\beta z),$$

from (1, 2, 9.6.2.12) it follows that

$$\Omega = \Psi_{cc} + \Psi_{ss}, \quad (3)$$

$$\Psi = \Psi_{sc} + \Psi_{cs}. \quad (4)$$

Further we shall denote all the quantities for cases 1 and 2 by one or two strokes correspondingly. Let us assume that

$$\rho = \rho' + \rho'', \quad (5a)$$

$$\sigma = \sigma' + \sigma''. \quad (5b)$$

Then

$$\rho = \rho_0 \Omega e^{\lambda x + \gamma y}, \quad (6)$$

$$\sigma = \sigma_0 \Omega e^{\lambda x + \gamma y}. \quad (7)$$

Physically it means that the charges are grouped around the  $\mathbf{z}$  axis, they move along this axis and change their value with time. In the physical sense it means that the charges are grouped beside the  $\mathbf{z}$  axis.

Owing to (3, 4, 5) and the system's (9.5.1) linearity, the summary electromagnetic field for this case may be found the sum of solutions for cases 1 and 2. As the system (9.5.1) is linear, the summary electromagnetic field may be found from the sum of solutions 1 and 2. Therefore, in this case

$$\left[ E_x, E_y, E_z, H_x, H_y, H_z, \varphi, \phi \right] = e^{\lambda x + \gamma y} \cdot \bar{q} \cdot \left[ \Omega, \Omega, \Psi, \Omega, \Omega, \Psi, \Psi, \Psi \right] \quad (7a)$$

where real numbers  $\bar{q}$  are determined by (9.7.1.4) – see also Table 1 (version 3).

From (1.7) we get:

$$\mathbf{g} \circ (\Lambda' + \Lambda'') = 0, \quad (8)$$

where  $\Lambda'$ ,  $\Lambda''$  are determined correspondingly by (1.6) and (2.3). But

$$\Lambda = \Lambda' + \Lambda''$$

where, on account of (3, 4),

$$\Lambda^T = e^{\lambda x + \gamma y} \cdot \left[ \Omega, \Omega, \Psi, \Omega, \Omega, \Psi, \Psi, \Psi \right]. \quad (9)$$

Therefore in this case also the parameters  $e_x, e_y, e_z, h_x, h_y, h_z, \varphi_0, \phi_0$  are functions of  $\chi, \gamma, \beta, \omega, \rho_0, \sigma_0$ , which are also determined from the solution of the linear equations system (1.5a).

The program `section9731a.dfw` in the DERIVE system performs the indicated processing: substitutes the functions (1, 2, 7a) and (9.6.5.2) into the Maxwell equations system (9.5.1), differentiates this system, cancels the common factors (9) and computes the functions  $\mathbf{g} = \mathbf{0}$ , which turn out to be equal to functions (1.5a).

The equations system (1.5a) may be solved in symbolic form (for example, in the DERIVE system (see program `section9732.dfw`) with respect to the unknowns  $\bar{q} = [e_x, e_y, e_z, h_x, h_y, h_z, \varphi_0, \phi_0]$ . This solution has the following form:

$$\begin{aligned} e_x &= \frac{-\rho_0 \chi}{a \varepsilon}, & e_y &= \frac{-\rho_0 \gamma}{a \varepsilon}, & e_z &= \frac{\rho_0 \beta}{a \varepsilon}, & \varphi &= \frac{\rho_0 \omega}{a \mathcal{G}}, \\ h_x &= \frac{-\sigma_0 \chi}{a \mu}, & h_y &= \frac{-\sigma_0 \gamma}{a \mu}, & h_z &= \frac{\sigma_0 \beta}{a \mu}, & \phi &= \frac{\sigma_0 \omega}{a \zeta}, \end{aligned} \quad (10)$$

where

$$a = \beta^2 - \chi^2 - \gamma^2. \quad (11)$$

For a given  $\omega$  from (10) we may find the products  $\varphi_0 \mathcal{G} = -\frac{\rho_0 \omega}{a}$ ,  $\phi_0 \zeta = -\frac{\sigma_0 \omega}{a}$ . The first of these formulas determines the product of electric resistance  $\mathcal{G}$  of the environment by the electric scalar potential  $\varphi_0$ , which creates no questions. The second of these formulas determines the product of magnetic resistance  $\zeta$  of the environment by magnetic scalar potential  $\phi_0$ . In the section 9.6.5 we have already discussed the question of how this values may be interpreted.

Thus, the functions (6, 7) cannot be represented in the form of (9.6.2.11). Nevertheless the presented method may be applied in this case as well [29].

Turning to the physical interpretation of this problem we must note that that the discussed Maxwell equations system (9.5.1) in this case describes the situation when the charges are concentrated on the  $z$  axis, and move (as a current) along this axis. The magnetic charges may be imitated by the poles of magnetic dipoles. In this interpretation the following thing is interesting. Along the  $OZ$  axis an electromagnetic field  $H_z, E_z$  appears, as the consequence of wave distribution of the charges along the  $Z$  axis (independent of the form of charge density

distribution along the axes  $ox$  and  $oy$ ). This electromagnetic field is a longitudinal electromagnetic wave. Note that the existence of such waves does not contradict the Maxwell's electrodynamics [30]. The experiment showing existence of longitudinal waves, is described in section 9.8.5a.

### 3a. Electromagnetic oscillations at compound motion of the exponentially distributed charges

Let us consider without deduction one more case of moving charges.

Let us denote:

$$\Omega = \text{Cos}(\omega t + \gamma y + \beta z), \quad (1)$$

$$\Psi = \text{Sin}(\omega t + \gamma y + \beta z), \quad (2)$$

Let

$$\rho = \rho_o \Omega e^{\lambda x}, \quad (3)$$

$$\sigma = \sigma_o \Psi e^{\lambda x}, \quad (4)$$

$$\left[ E_x, E_y, E_z, H_x, H_y, H_z, \varphi, \phi \right] = e^{\lambda x} \cdot \bar{q} \cdot \left[ \Omega, \Psi, \Psi, \Psi, \Omega, \Omega, \Psi, \Omega \right], \quad (5)$$

where real numbers  $\bar{q}$  are determined by (9.7.1.4).

Physically it means that the charges are grouped around the  $z$  axis they are moving along axes  $oy$  and  $oz$ , changing by value with the time. In this case

$$\mathbf{g} \circ \Lambda = \mathbf{0}, \quad (6)$$

where

$$\Lambda^T = e^{\lambda x} \cdot \left[ \Psi, \Omega, \Omega, \Omega, \Psi, \Psi, \Omega, \Psi \right]. \quad (7)$$

The program section 973a.dfw in the DERIVE system performs the indicated processing: substitutes the functions (1-5) into the Maxwell equations system (9.5.1), differentiates this system, cancels the common factors (7) and determines the functions  $\mathbf{g} = \mathbf{0}$ . Then the equations system  $\mathbf{g} = \mathbf{0}$  may be solved in symbolic form with respect to the unknowns  $\bar{q} = \left[ e_x, e_y, e_z, h_x, h_y, h_z, \varphi_o, \phi_o \right]$ . This solution has the following form:

$$e_x = \frac{-\rho_o \chi}{a \varepsilon}, \quad e_y = \frac{\rho_o \alpha}{a \varepsilon}, \quad e_z = \frac{\rho_o \beta}{a \varepsilon}, \quad \varphi = \frac{\rho_o \omega}{a \vartheta},$$

$$h_x = \frac{-\sigma_o \chi}{a \mu}, \quad h_y = \frac{-\sigma_o \gamma}{a \mu}, \quad h_z = \frac{-\sigma_o \beta}{a \mu}, \quad \phi = \frac{-\sigma_o \omega}{a \zeta},$$
(8)

where

$$a = \beta^2 + \gamma^2 - \chi^2. \tag{9}$$

**4. Magnetic oscillations with charges distributed according to Dirac function. Case 1.**

Let us return to the problem discussed in Section 9.6.7a, the magnetic charges density distribution function is considered known

$$\sigma = \sigma_o \Psi_{ss} \lambda'(x) e^{\gamma y}, \tag{10}$$

which follows from (9.6.2.10, 9.6.6.1, 9.6.7.1). here we again, unlike the (9.6.2.12), shall define the functions  $\Psi$  in the form (9.8.1.2a,b,c,d)

For clearness sake, in the Table 2 the functions  $\Psi$ , included in (1, 9.8.1.3), are enumerated – see version 1.

Table 2.

| $q$          | $\bar{q}$  | $q_x$          | Variants    |             |          |
|--------------|------------|----------------|-------------|-------------|----------|
|              |            |                | 1           | 2           | 3        |
| $q_4 = H_x$  | $h_x$      | $-Cos(\chi x)$ | $\Psi_{ss}$ | $\Psi_{cc}$ | $\Omega$ |
| $q_5 = H_y$  | $h_y$      | $-Sin(\chi x)$ | $\Psi_{ss}$ | $\Psi_{cc}$ | $\Omega$ |
| $q_6 = H_z$  | $h_z$      | $-Sin(\chi x)$ | $\Psi_{sc}$ | $\Psi_{cs}$ | $\Psi$   |
| $q_8 = \phi$ | $\phi_o$   | $-Sin(\chi x)$ | $\Psi_{cs}$ | $\Psi_{sc}$ | $\Psi$   |
| $\sigma$     | $\sigma_o$ | $\lambda'(x)$  | $\Psi_{ss}$ | $\Psi_{cc}$ | $\Omega$ |

The Maxwell equations (9.5.1) in this case take the form (9.6.7a.1-8), and their solution is (9.6.7a.9, 9.6.7a.12, 9.6.7a.13, 9.6.7a.14, 9.6.7a.17).

**5. Magnetic oscillations with charges distributed according to Dirac function. Case 2.**

Let us assume now that unlike (9.8.4.0),

$$\sigma = \sigma_o \Psi_{cc} \lambda'(x) e^{\gamma y}, \tag{1}$$

Then by analogy with the previous discussion, we may find  $\Psi$ , which assume the values enumerated in the Table 2 (version 2). The Maxwell equations (9.5.1) in this case also take the form (9.6.7a.1-8), and their solution is (9.6.7a.9, 9.6.7a.12, 9.6.7a.13, 9.6.7a.14, 9.6.7a.17).

### 6. Magnetic oscillations with linear movement of charges, distributed according to Dirac function

Reasoning in the same way as in Section 9.8.3, and bearing in mind formulas (9.8.3.1-5, we see that

$$\sigma = \sigma_o \Omega \lambda'(x) e^{\mathcal{N}}. \quad (1)$$

In the physical sense it means that the charges are grouped beside the  $\mathbf{z}$  axis and are changing their value with the time. The along distribution of the charges along the  $x$  axis is described by the Dirac function, which means that there is stepwise change of the density distribution the axis  $ox$ .

In view of the system's (9.5.1) linearity, the summary electromagnetic field may be found from the sum of solutions for cases 4 and 5. The Maxwell equations (9.5.1) in this case also take the form (9.6.7a.1-8). Therefore, in this case the functions  $\Psi$  assume the values enumerated in the Table. 2 (version 3). The solutions of equations (9.6.7a.1-8) here also certainly have the form (9.6.7a.9, 9.6.7a.12, 9.6.7a.13, 9.6.7a.14, 9.6.7a.17), i.e.

$$\chi \approx \sqrt{\gamma^2 + \beta^2}, \quad (2)$$

$$h_x = \sigma_o / \mu, \quad (3)$$

$$h_z = h_x \beta / \chi, \quad (4)$$

$$h_y = h_x \gamma / \chi, \quad (5)$$

$$\zeta \phi_o = -h_x \mu \omega / \chi = -h_y \mu \omega / \gamma = -h_z \mu \omega / \beta. \quad (6)$$

Thus, for given  $\sigma_o, \gamma, \beta, \omega$  by (2-6) all the parameters of magnetic wave  $h_x, h_z, h_y, \zeta \phi_o, \chi$  accordingly, may be found.

Let us note also that for  $\omega = 0$  the equations (2-5) describe a magnetostatic field.

So, the function (1) cannot be represented in the form (9.6.2.11). Nevertheless, the presented method is applicable in this case also.

Similar formulas may be derived for electric oscillations.



Turning to the physical interpretation of this problem, we see that in this case (as in the case 9.7.3) along the axis  $OZ$  a magnetic field  $H_z$  is originated, and it is a longitudinal magnetic wave (in 9.7.3 there was a longitudinal electromagnetic wave). Furthermore, in this case due to stepwise change of density distribution of charged along the axis  $Ox$  a magnetic field  $H_x$  appears, which is a stationary wave. Indeed, the nodes of this wave on the  $Ox$  axis do not move with the time. As in this case the electric field is absent, so there is no exchange of energy between magnetic and electric fields, as it occurs in the known stationary electromagnetic waves. Therefore, in this case we have an volatile stationary magnetic wave.

Above we had noted that for this case there is a symmetry of electric and magnetic fields. Because of disconnectedness of magnetic and electric waves in an electromagnetic wave (which appears if there are both electric and magnetic charges) along the  $Ox$  axis there also appear two disconnected electric and magnetic stationary waves. They may have different periods, but if the periods coincide, the electric and magnetic waves components will be in-phase. It may be seen in the example of the Section 9.6.7.1 and generally in the examples of Sections 9.6.7, 9.6.8, 9.6.9.

It is notable that in the known stationary wave the magnetic and electric components of the wave have phase displacement of  $\pi/2$ . These questions are more in detail considered in [40].

## 8. Example. Electromagnetic radiation of the localized charges.

### 1. Problem definition

Let us consider a problem where the vectors  $q_x, q_y, q_z, q_t$  are of the form presented in Table 1.

Table 1.

| $q$             | $\bar{q}$   | $q_x$             | $q_y$          | $q_z$         | $q_t$                   | $q_x$ (calc)          |
|-----------------|-------------|-------------------|----------------|---------------|-------------------------|-----------------------|
| $q_1 = E_x$     | $e_x$       | $E_{xfx}(x)$      | $e^{\gamma y}$ | $e^{\beta z}$ | $\text{Cos}(\omega t)$  | $-\text{Cos}(\chi x)$ |
| $q_2 = E_y$     | $e_y$       | $E_{yfx}(x)$      | $e^{\gamma y}$ | $e^{\beta z}$ | $\text{Cos}(\omega t)$  | $-\text{Sin}(\chi x)$ |
| $q_3 = E_z$     | $e_z$       | $E_{zfx}(x)$      | $e^{\gamma y}$ | $e^{\beta z}$ | $\text{Cos}(\omega t)$  | $-\text{Sin}(\chi x)$ |
| $q_4 = H_x$     | $h_x$       | $H_{xfx}(x)$      | $e^{\gamma y}$ | $e^{\beta z}$ | $\text{Sin}(\omega t)$  | $-\text{Cos}(\chi x)$ |
| $q_5 = H_y$     | $h_y$       | $H_{yfx}(x)$      | $e^{\gamma y}$ | $e^{\beta z}$ | $\text{Sin}(\omega t)$  | $-\text{Sin}(\chi x)$ |
| $q_6 = H_z$     | $h_z$       | $H_{zfx}(x)$      | $e^{\gamma y}$ | $e^{\beta z}$ | $\text{Sin}(\omega t)$  | $-\text{Sin}(\chi x)$ |
| $q_7 = \varphi$ | $\varphi_0$ | $\varphi_{fx}(x)$ | $e^{\gamma y}$ | $e^{\beta z}$ | $-\text{Sin}(\omega t)$ | $-\text{Sin}(\chi x)$ |
| $q_8 = \phi$    | $\phi_0$    | $\varphi_{fx}(x)$ | $e^{\gamma y}$ | $e^{\beta z}$ | $-\text{Cos}(\omega t)$ | $-\text{Sin}(\chi x)$ |

At that

$$E_x = e_x \text{Cos}(\omega t) e^{\gamma y + \beta z} E_{xfx}(x), \quad (1)$$

$$E_y = e_y \text{Cos}(\omega t) e^{\gamma y + \beta z} E_{yfx}(x), \quad (2)$$

$$E_z = -e_z \text{Cos}(\omega t) e^{\gamma y + \beta z} E_{zfx}(x), \quad (3)$$

$$H_x = h_x \text{Sin}(\omega t) e^{\gamma y + \beta z} H_{xfx}(x), \quad (4)$$

$$H_y = h_y \text{Sin}(\omega t) e^{\gamma y + \beta z} H_{yfx}(x), \quad (5)$$

$$H_z = -h_z \text{Sin}(\omega t) e^{\gamma y + \beta z} H_{zfx}(x), \quad (6)$$

$$\varphi = -\varphi_0 \text{Sin}(\omega t) e^{\gamma y + \beta z} \varphi_{fx}(x), \quad (7)$$

$$\phi = -\phi_o \text{Cos}(\omega t) e^{\gamma y + \beta z} \phi_{fx}(x), \tag{8}$$

$$\rho = \rho_o \text{Cos}(\omega t) e^{\gamma y + \beta z} \Xi, \tag{9}$$

$$\sigma = \sigma_o \text{Sin}(\omega t) e^{\gamma y + \beta z} \Xi, \tag{10}$$

where

$$e_x, e_y, e_z, h_x, h_y, h_z, \varphi_o, \phi_o, \rho_o, \sigma_o \tag{11}$$

are real numbers,

$$E_{xf}, H_{xf}, \varphi_{xf}, \phi_{xf} \tag{14}$$

are unknown functions,

$$\Xi = \Xi_x(x) \tag{15}$$

a known function, whose form will be discussed later.

The problem, as before, is as follows: for certain unknown coefficients from manifold (11), for certain function  $\Xi$  (15), by Maxwell equations system (9.5.1) find the form of functions (14) and the unknown coefficients for manifold (11).

## 2. Computing vectors (9.5.7, 9.5.9)

Table 2.

|             | 7                                   | 8                                |
|-------------|-------------------------------------|----------------------------------|
| $U$         | $\rho$ - cm. (9.7.1.9)              | $\sigma$ - cm. (9.7.1.10)        |
| $\bar{U}$   | $\rho_o$                            | $\sigma_o$                       |
| $U_x$       | $\Xi_x(x)$                          | $\Xi_x(x)$                       |
| $U_y$       | $e^{\gamma y}$                      | $e^{\gamma y}$                   |
| $U_z$       | $e^{\beta z}$                       | $e^{\beta z}$                    |
| $U_t$       | $\text{Cos}(\omega t)$              | $\text{Sin}(\omega t)$           |
| $\hat{u}_x$ | $\oint_x \varphi_{fx}(x) \Xi(x) dx$ | $\oint_x \phi_{fx}(x) \Xi(x) dx$ |
| $\hat{u}_y$ | $a_y$ - see (9.6.1.7)               | $a_y$ - see (9.6.1.7)            |
| $\hat{u}_z$ | $a_z$ - see (9.6.1.7c)              | $a_z$ - see (9.6.1.7c)           |
| $\hat{u}_t$ | $a_t$ - see (9.6.1.17)              | $a_t$ - see (9.6.1.17)           |
| $V_x$       | $a_t a_z a_y \Xi(x)$                | $a_t a_z a_y \Xi(x)$             |

Let us take the vectors (9.6.3.39-41) and build for this problem a Table 2, similar to the Table 9.6.2. For known functions  $q$  and  $U$  the numbers (9.5.5) may be found. They are shown in the Table 2. To compute these numbers we shall use Table 1, showing the numbers  $q_x, q_y, q_z, q_t$ .

### 3. Computations

From formulas (9.5.4, 9.6.1.5, 9.6.1.18, 9.6.1.7a) follows:

$$\bar{R}_x = R_x \circ Q_t \circ Q_y \circ Q_z = a_z a_y a_t R_x. \quad (1)$$

From formulas (9.5.16, 9.6.1.5, 9.6.1.19, 9.6.1.7a) follows:

$$R_{tyz} = R_t \circ \hat{Q}_t \circ Q_y \circ Q_z = a_z a_y a_t \omega R_t. \quad (2)$$

From formulas (9.5.17, 9.6.1.6, 9.6.1.18, 9.6.1.7a) follows:

$$R_{ytz} = R_y \circ \hat{Q}_y \circ Q_t \circ Q_z = \gamma a_y a_z a_t R_y. \quad (3)$$

From formulas (9.5.18, 9.6.1.7b, 9.6.1.18, 9.6.1.4) follows:

$$R_{zty} = R_z \circ \hat{Q}_z \circ Q_t \circ Q_y = \beta a_z a_y a_t R_z. \quad (4)$$

Then the matrix (9.5.19) is determined. Furthermore, on the same iteration the functions  $U_t, U_y, U_z$  are being fixed, and by them (as shown in Section 6.3) the vector-function (9.5.7)  $V_x$  is determined. After this vector-function  $q_x$  is found from the equation (9.2.17)

$$S_x q_x + \bar{R}_x \left( \frac{dq_x}{dx} \right) + \bar{U} \circ V_x = 0. \quad (5)$$

### 4. Modeling of wave with electric and magnetic charges exponentially distributed along $y, z$ axes and with Dirac distribution along $x$ axis.

Similarly to Section 9.6.7 we shall consider the charges with density distribution along the  $x$  axis:

$$\Xi(x) = \lambda'(x). \quad (1)$$

where  $\lambda'$  is a Dirac function, and exponential density distribution along  $y$  and  $z$  axes (as above). Thus,

$$\rho = \rho_o \text{Cos}(\omega t) e^{\gamma y + \beta z} \lambda'(x), \quad (1a)$$

$$\sigma = \sigma_o \text{Sin}(\omega t) e^{\gamma y + \beta z} \lambda'(x). \quad (1b)$$

By analogy with (9.6.7.2, 9.6.7.3) we find:

$$V_{x7} = \rho_0 a_t a_z a_y \Xi_x(x) = a_t a_z a_y \rho_0 \lambda'(x), \tag{2}$$

$$V_{x8} = \sigma_0 a_t a_z a_y \Xi_x(x) = a_t a_z a_y \sigma_0 \lambda'(x). \tag{3}$$

Then, by analogy with formula (9.6.5.9) we shall get

$$\left\{ \begin{aligned} & (\gamma R_y + \beta R_z + \omega R_t) \lambda_x + R_x \left( \frac{dq_x}{dx} \right) \\ & + [0, 0, 0, 0, 0, 0, \rho_0, \sigma_0]^T \cdot \lambda'(x) \end{aligned} \right\} = 0. \tag{4}$$

The equation (4) is a differential equation with Dirac functions as perturbations. A method for solving such equations was given in Section 6.6. Let us apply this method.

**Example 1.** Consider equation (4) and set the values of  $\omega, \gamma, \beta, \rho_0, \sigma_0$ . To solve equation (4) we shall use `DEdirac` function. The function `testFloid` contains access to this function and performs the computation for  $\omega = 50, \gamma = 70, \beta = 70, \rho_0 = 5 \cdot 10^4, \sigma_0 = 2 \cdot 10^5$ .

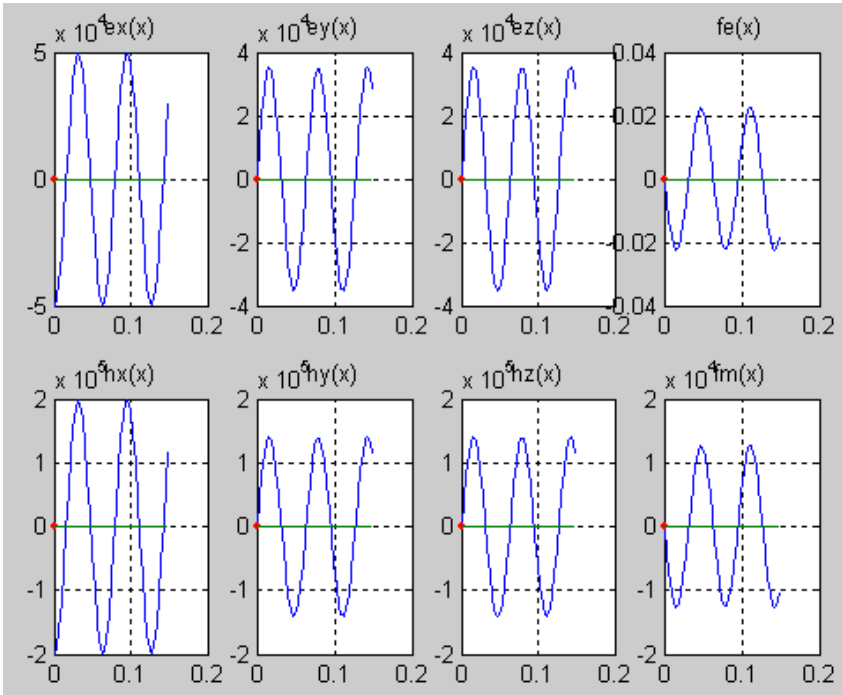

Fig. 1.

The result is given on Figure 1, where the required functions are shown. The periodic functions have circular frequency  $\chi = 99$ .

Thus, when solving the equation (9.7.5.4) the functions (9.7.2.14) take the form shown in Table 9.7.2.1 – see column  $q_x$  (calc). Substituting these functions to the Maxwell equation (9.5.1.1), we find:

$$\left( \begin{array}{l} (\beta h_y - h_z \gamma) \text{Sin}(\chi x) \\ + (\epsilon \omega \epsilon_x - \mathcal{G} \varphi_0 \chi) \text{Cos}(\chi x) \end{array} \right) e^{\gamma y + \beta z} \text{Cos}(\omega t) = 0.$$

Evidently, this equation splits in two independent equations with respect to the components of electric and magnetic fields. The program `section984.dfw` in the DERIVE system substitutes the functions from table 6.2.1 into the Maxwell equations system (9.5.1) and differentiates this system. It is now obvious that the same may be said about all equations in the equations system (9.5.1). Hence it follows that under conditions of this problem electric waves may appear in the absence of magnetic waves and vice versa.

#### 4a. Modeling of wave with magnetic charges distributed periodically along the $y$ , $z$ axes and with Dirac distribution along $x$ axis.

By analogy with Section 9.8.5 we shall deal with charges with density distribution along the  $x$  axis of the form of Dirac function (9.8.5.1), but (unlike Section 9.8.5) with periodical density distribution along the axes  $y$  and  $z$ . To put it more precisely,

$$\rho = \rho_o \text{Cos}(\omega t) \text{Cos}(\gamma y) \text{Cos}(\beta z) \mathcal{N}'(x), \quad (1)$$

$$\sigma = \sigma_o \text{Sin}(\omega t) \text{Cos}(\gamma y) \text{Cos}(\beta z) \mathcal{N}'(x). \quad (2)$$

By analogy with Section 9.8.5 it may be shown that in this case all the equations (9.5.1) fall into two independent equations with respect to the components of electric and magnetic fields. The program `section984a.dfw` in the DERIVE system contains the solution of equation (9.5.1), performs substitution of this solution into Maxwell equations system (9.5.1) and differentiates this system. The above said remark is being confirmed here.

As opposed to (1, 2) we may consider another couple of equations for electrical and magnetic charges density distribution:

$$\rho = \rho_o \text{Cos}(\omega t) \text{Cos}(\gamma y) \text{Cos}(\beta z) \mathcal{N}'(x), \quad (3)$$

$$\sigma = \sigma_o \text{Cos}(\omega t) \text{Cos}(\gamma y) \text{Cos}(\beta z) \lambda'(x). \quad (4)$$

The distinction is only in the fact that these distributions are cophasal, and in this case it is easy to show that all the equations (9.5.1) break up into two independent equations with respect to the components of electric and magnetic fields. The function section984a.2.dfw (similar to function section984a.dfw) confirms the above mentioned remark..

### 5. Modeling of wave with magnetic charges distributed exponentially along the axes $y$ , $z$ and with Dirac function distribution along $x$ axis

Let us take now the equations system (9.5.1) in Section 9.8.4 under condition that there exists only a magnetic field. Thus, for example, the equation (9.8.4.1) is corresponded to by the equation

$$(\beta h_y - h_z \gamma) \text{Sin}(\chi x) e^{\gamma y + \beta z} \text{Cos}(\omega t) = 0. \quad (1)$$

corresponds in this case to the equation (9.6.7a.1). In future in the equations of this system the factors of the type

$\text{Sin}(\chi x) e^{\gamma y + \beta z} \text{Cos}(\omega t)$  will not be shown.

$$(h_x \beta - \chi h_z) = 0, \quad (2)$$

$$(\gamma h_x - \chi h_y) = 0, \quad (3)$$

$$\mu \omega h_x + \zeta \chi \phi_o = 0, \quad (4)$$

$$\mu \omega h_y + \zeta \gamma \phi_o = 0, \quad (5)$$

$$\mu \omega h_z + \zeta \beta \phi_o = 0, \quad (6)$$

$$\chi h_x - \gamma h_y - \beta h_z - \sigma_o / \mu = 0. \quad (8)$$

So, in this case the magnetic wave changes in time and space along the  $x$  axis, and along the axes  $y$ ,  $z$  it is limited by function  $e^{\gamma y + \beta z}$ . The solutions of equations (1-8) are determined, as in Section 9.7.6, in the following form:

$$\chi \approx \sqrt{(\gamma^2 + \beta^2)}, \quad (2)$$

$$h_x = \sigma_o / \mu, \quad (3)$$

$$h_z = h_x \beta / \chi, \quad (4)$$

$$h_y = h_x \gamma / \chi, \quad (5)$$

$$\zeta \phi_0 = -h_x \mu \omega / \chi = -h_y \mu \omega / \gamma = -h_z \mu \omega / \beta. \quad (6)$$

As also in Section 9.7.6, one may note that in this magnetic wave, due to stepwise change of the charges density distribution along  $OX$  axis, there appears a magnetic field  $H_x$ , which is a energy-dependent standing magnetic wave.

For  $\omega = 0$  the equations (2-5) describe a magnetostatic field.

**5a. Modeling of wave with magnetic charges periodically distributed along the axes  $y, z$  and with Dirac distribution along the  $x$  axis**

Let us consider now Maxwell equations system (9.5.1) of Section 9.8.4a under condition that there exists only the magnetic field. In this case, by analogy with Section 9.8.5 the following equations system is true:

$$\left. \begin{aligned} (\gamma h_z - h_y \beta) &= 0 \\ (h_x \beta + \chi h_z) &= 0 \\ (\gamma h_x + \chi h_y) &= 0 \\ \mu \omega h_x + \zeta \chi \phi_0 &= 0 \\ \mu \omega h_y - \zeta \gamma \phi_0 &= 0 \\ \mu \omega h_z - \zeta \beta \phi_0 &= 0 \\ \chi h_x - \gamma h_y - \beta h_z - \sigma_0 / \mu &= 0 \end{aligned} \right| \quad (1)$$

The solution of equations (1) are determined (as also in Section 9.8.5) in the following form:

$$\chi \approx \sqrt{(\gamma^2 + \beta^2)}, \quad (2)$$

$$h_x = \sigma_0 / \mu, \quad (3)$$

$$h_z = h_y \beta / \gamma, \quad (4)$$

$$h_y = -h_x \gamma / \chi, \quad (5)$$

$$\zeta \phi_0 = -h_x \mu \omega / \chi = h_y \mu \omega / \gamma = h_z \mu \omega / \beta. \quad (6)$$

As in Section 9.8.5, one may note that in this magnetic wave, due to stepwise change (the charge is at an end face, but is absent outside of an end face) of the density distribution of charges along the axis  $OX$  a



magnetic field emerges in the form of volatile stationary longitudinal magnetic wave, with a component  $H_x$ . The intensities in this wave are described by

$$H_x = h_x \text{Cos}(\omega t) \text{Cos}(\gamma y) \text{Cos}(\beta z) \text{Cos}(\chi x), \quad (7)$$

$$H_y = h_y \text{Cos}(\omega t) \text{Sin}(\gamma y) \text{Cos}(\beta z) \text{Sin}(\chi x), \quad (8)$$

$$H_z = h_z \text{Cos}(\omega t) \text{Cos}(\gamma y) \text{Sin}(\beta z) \text{Sin}(\chi x). \quad (9)$$

For  $\omega = 0$  the equations (2-5) describe a magnetostatic field.

Let us consider now a function of a more general nature than (9.4a.2), describing magnetic charges density distribution in space

$$\rho = \rho_o \text{Cos}(\omega t) f_y(y) f_z(z) \mathcal{N}'(x). \quad (10)$$

Let us assume that the functions  $f_y(y)$ ,  $f_z(z)$  are of a similar form and may be expanded into trigonometrical series. We shall denote them by a common symbol  $f(\cdot)$ . Then in the same way as above it may be shown that the intensities distribution functions are of the form

$$H_x = h_x \text{Cos}(\omega t) f(y) f(z) f(x), \quad (11)$$

$$H_y = h_y \text{Cos}(\omega t) \frac{df(y)}{dy} f(z) \frac{df(x)}{dx}, \quad (12)$$

$$H_z = h_z \text{Cos}(\omega t) f(y) \frac{df(z)}{dz} \frac{df(x)}{dx}. \quad (13)$$

From this, in particular, follows that for fixed  $x, z, t$

$$H_y(y) \equiv \frac{H_x(y)}{dy}, \quad (13a)$$

and for fixed  $y, z, t$

$$H_y(x) \equiv \frac{H_x(x)}{dx}. \quad (13b)$$

Here the sense of a designation ' $\equiv$ ' consists that functions coincide to within constant coefficient.

**Example 1.** Let us consider a cylindrical magnet depicted on Figure1. Its residual induction is equal to 1.1 Tl, diameter is 20 mm and length – 20mm. An experimental device for the measurement of such magnet's magnetic field and the intensities of this field is described in [41]. The results of measurements of the magnetic field

intensities (for  $x=1\text{mm}$ ) near the face plane may be approximated by following empirical functions:

$$H_x(y) = 400e^{-0.0004y^4}, \quad (14)$$

$$H_y(y) = -1.8y^3e^{-0.0004y^4}. \quad (15)$$

Thus, the formula (13a) is confirmed, correct to a constant coefficient. The graphs of functions (14, 15) are shown on Figure 2. On the same Figure there are graphs (depicted by dotted lines) of the first harmonics of these empirical functions expansion into trigonometric series – see the function  $H_{xy}$ . For these harmonics

$$H_x(y) = 200(1 + \text{Cos}(0.27y)), \quad (14a)$$

$$H_y(y) = -280\text{Sin}(0.27y). \quad (15a)$$

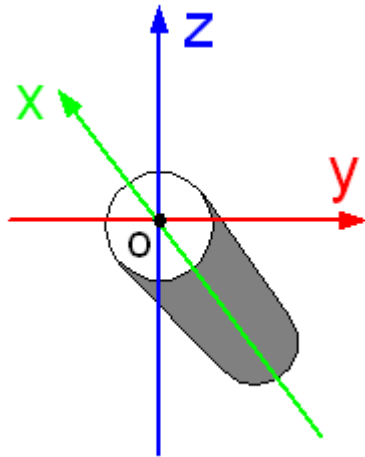

Fig. 1.

Since, as follows from (10, 11) for fixed  $x, z, t$

$$H_x(y) \equiv \rho(y) \equiv f(y), \quad (16)$$

correct to a constant coefficient, so we must assume that the magnetic charges density distribution along the face plane axes has the form of (14) or (14a). Separating from (14a) the variable part, we find:

$$f(y) = e^{-0.0004y^4}. \quad (17)$$

From (12) follows that

$$H_y(y) \equiv \frac{df(y)}{dy}, \quad (18)$$

From (15a, 18) follows that

$$\frac{df(y)}{dy} \approx \text{Sin}(0.27y). \quad (18a)$$

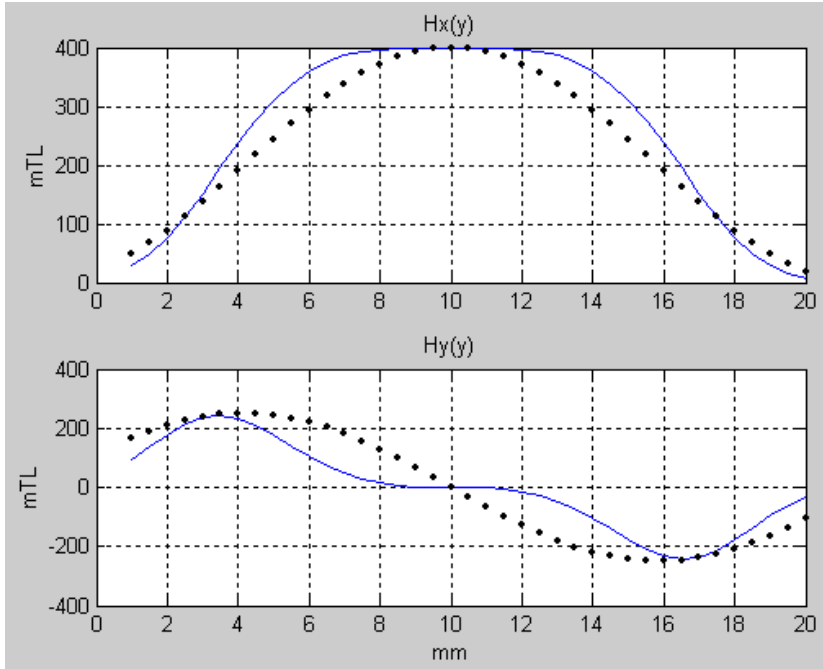

Fig. 2. The upper window -  $H_x(y)$ , the lower window -  $H_y(y)$ , firm lines - experimental approximation, dotted lines - the first harmonic of trigonometrical series expansion.

This follows (correct to a constant) also from (17), which confirms experimentally the formula (12). Then according to (11, 12, 17, 18a) we may expect

$$H_x(x) \equiv f(x) \approx \text{Cos}(0.27x), \quad (19)$$

$$H_y(x) \equiv \frac{df(x)}{dx} \approx \text{Sin}(0.27x). \quad (20)$$

To confirm the correctness of (19, 20) we have made appropriate experimental dependences. For the building of dependence  $H_x(x)$  along the magnet's axis of symmetry (axis  $x$ , where  $x=0$  on the face plane)

- The intensity  $H'_x(x)$  in the axis points has been measured,
- The intensity  $H''_x(x)$  in the same points for the equivalent solenoid has been measured,
- And finally, the sought intensity was computed (the variable component which cannot be predicted by the existing theory)

$$H_x(x) = (H'_x(x) - H''_x(x)). \quad (22)$$

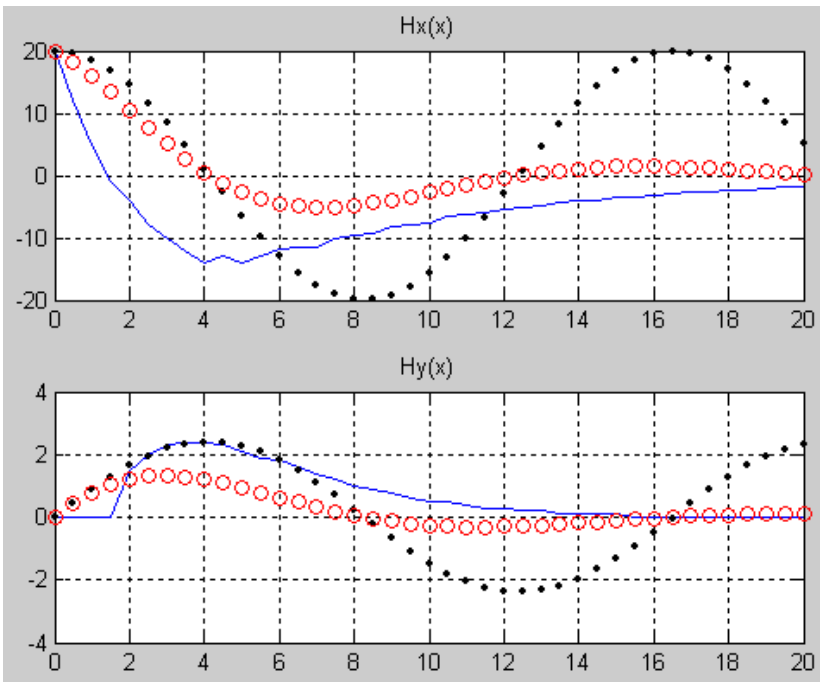

Fig. 3. The upper window -  $H_x(x)$ , the lower window -  $H_y(x)$ , firm lines - experimental approximation, dotted lines - the first harmonic of trigonometrical series expansion, lines made of circles - «weakened» first harmonic of trigonometrical series expansion.

Fig. 3 (upper window) shows the graph of this experimentally found function (22) – see function HxyExper2. It is easy to see that the first harmonic of this function has the shape of cosine

$$H_x(x) \equiv \text{Cos}(\chi x) \quad (23)$$

and coincide with function (17). It proves that the experiment has revealed the oscillatory nature of the function  $H_x(x)$ .

For the building of dependence  $H_y(x)$  along the magnet's axis of symmetry

- The intensity  $H'_y(x)$  in the axis points has been measured,
- The intensity in the same points of the equivalent solenoid for check of identity  $H''_y(x) \equiv 0$  was computed
- Required intensity was computed

$$H_y(x) = H'_y(x). \quad (24)$$

Figure 3 (lower window) shows the graph of this experimentally found function (24) – see function HxyExper. It is easy to see that the first harmonic of this function has the shape of sine.

$$H_y(x) \equiv \text{Sin}(\chi x) \quad (25)$$

and coincide with function (20). It proves that the experiment has revealed the oscillatory nature of the function  $H_y(x)$ .

Note, that from (2) for  $\beta = \gamma$  follows (due to the face plane's symmetry)

$$\chi \approx \gamma\sqrt{2}. \quad (26)$$

From Figure. 3 and formulas (23, 25) follows also that formula (13B) is valid. One can see that the period  $\chi$  of the first harmonics of functions  $H_x(x)$ ,  $H_y(x)$  and the period  $\gamma$  of the first harmonics of functions  $H_x(y)$ ,  $H_y(y)$  answer the formula (26).

Let us continue the comparison of theory with experiment, to do so we shall consider the weakening of intensities when moving away from the magnet face plane. We shall define the weakening coefficient as

$$K(x) = H''_x(0) / H''_x(x), \quad (27)$$

where  $H_x''(x)$  as before, denotes the computed intensity of the equivalent solenoid. Apparently, we should assume that the intensities  $H_x(x)$ ,  $H_y(x)$  are weakening with the same coefficient of weakening. Apparently, it is necessary to believe, that the order of easing intensities  $H_x(x)$ ,  $H_y(x)$ , it will be characterized by the same factor of easing. In this assumption we may compute the "weakened" intensities

$$\bar{H}_x(x) = H_x(x) / K(x),$$

$$\bar{H}_y(x) = H_y(x) / K(x).$$

Figure. 3 depicts by "circle lines" the graphs of these functions, computed for the first harmonics (23, 25).

Considering possible errors of measurements, it is possible to ascertain the satisfactory consent between the theory and experiment. Thus, executed experiment reveals intensity waves of the magnetic field in the direction of constant magnet's axis, which confirms the presented theory and the existence of longitudinal magnetic waves in which the change  $H_x(x)$  occurs.

## 6. Modeling of wave with electric charges exponentially distributed along the axes $y$ , $z$ and with Dirac distribution along the $x$ axis

We have remarked above on the symmetry on the symmetry of electric and magnetic fields. In view of disconnectedness of magnetic and electric waves in the electromagnetic wave (which appears in the presence of both magnetic and electric charges) along the axis  $ox$  there also appear two disconnected energy-dependent electric and magnetic standing waves. They may have different periods, but in the case of identical periods the electric and magnetic waves will be cophased. It may be seen on the Figure 1.

Let us consider now the equations system (9.5.1) under condition that there exists only electric field. We then get results fully identical to those obtained in Section 9.6.7b

As in Section 9.8.5, here it is easy to see that in this electric wave, due to stepwise change of the charges density distribution along the axis  $ox$ , an electric field  $E_x$  is generated, as a volatile stationary longitudinal wave.

For  $\omega = 0$  the equations (2-5) describe an electrostatic field.

---

**6a. Modeling of wave with electric charges distributed periodically along the axes  $y$ ,  $z$  and with Dirac distribution along the  $x$  axis**

Let us consider now the equations system (9.5.1) from Section 9.8.4a under condition that there exists only electric field. Owing to the symmetry of electric and magnetic fields we shall obtain results fully identical to the results obtained in Section 9.8.5a.

As in Section 9.8.5, here it is easy to see that in this electric wave, due to stepwise change of the charges density distribution along the axis  $OX$ , an electric field  $E_x$  is generated, as a volatile stationary longitudinal wave.

For  $\omega = 0$  the equations (2-5) describe an electrostatic field.

## 9. Analytical Method of Maxwell Equations Solution

### 9.1. Description of the method

From previous discussion it follows that for known density distribution functions it is possible to find the intensities functions and scalar potentials functions.. Further the method will be formalized to maximal extent.

Let us consider a system figuring magnetic and electric charges, whose density distribution is described by the following functions

$$\rho(x, y, z, t) = \rho_o \text{Chp}(\beta z + vt) \text{Shd}(\theta y) \Xi(x), \quad (1a)$$

$$\sigma(x, y, z, t) = \sigma_o \text{Chp}(\beta z + vt) \text{Chd}(\theta y) \Xi(x). \quad (1b)$$

We shall not discuss here the technical interpretation of this system.

So, we shall seek for the solution in form of the following magnetic intensity functions, electric intensity function and electric potential functions:

$$E_x(x, y, z, t) = \text{Chp}(\beta z + vt) \text{Shd}(\theta y) f_{ex}(x), \quad (2)$$

$$E_y(x, y, z, t) = \text{Chp}(\beta z + vt) \text{Chd}(\theta y) f_{ey}(x), \quad (3)$$

$$E_z(x, y, z, t) = \text{Shp}(\beta z + vt) \text{Shd}(\theta y) f_{ez}(x). \quad (4)$$

$$H_x(x, y, z, t) = \text{Chp}(\beta z + vt) \text{Chd}(\theta y) f_{hx}(x), \quad (5)$$

$$H_y(x, y, z, t) = \text{Chp}(\beta z + vt) \text{Shd}(\theta y) f_{hy}(x), \quad (6)$$

$$H_z(x, y, z, t) = \text{Shp}(\beta z + vt) \text{Chd}(\theta y) f_{hz}(x), \quad (7)$$

$$\varphi(x, y, z, t) = \text{Shp}(\beta z + vt) \text{Shd}(\theta y) f_{\varphi}(x), \quad (8)$$

$$\phi(x, y, z, t) = \text{Shp}(\beta z + vt) \text{Chd}(\theta y) f_{\phi}(x), \quad (9)$$

The form of function  $\Xi(x)$  is known. The functions

$$\text{Chp}(w), \text{Chd}(w), \text{Shp}(w), \text{Shd}(w) \quad (10)$$

are such, that

$$\frac{d(\text{Shp}(w))}{dw} = k_{sp} \text{Chp}(w), \quad (11)$$

$$\frac{d(\text{Chp}(w))}{dw} = k_{cp} \text{Shp}(w), \quad (12)$$



$$\frac{d(\text{Shd}(w))}{dw} = k_{sd} \text{Chd}(w), \quad (13)$$

$$\frac{d(\text{Chd}(w))}{dw} = k_{cd} \text{Shd}(w). \quad (14)$$

We must find functions

$$\begin{aligned} f_{ex}(x), f_{ey}(x), f_{ez}(x), f_{hx}(x), \\ f_{hy}(x), f_{hz}(x), f_{\varphi}(x), f_{\phi}(x) \end{aligned} \quad (15)$$

with respect of known  $\sigma_o, \rho_o, \beta, \theta, \nu$ .

By substituting the functions (1-8) into the Maxwell equations, differentiating according to rules (11-14) and reducing further by common factors, we get (see program section900.dfw):

$$\eta f'_{\varphi}(x) + \theta f_{hz}(x) K_{cd} - (\epsilon \nu f_{ex}(x) + \beta f_{hy}(x)) K_{cp} = 0, \quad (21)$$

$$\eta \theta f'_{\varphi}(x) K_{sd} - f'_{hz}(x) - (\epsilon \nu f_{ey}(x) - \beta f_{hx}(x)) K_{cp} = 0, \quad (22)$$

$$f'_{hy}(x) - \theta f_{hx}(x) K_{cd} + (\beta \eta f'_{\varphi}(x) - \epsilon \nu f_{ez}(x)) K_{sp} = 0, \quad (23)$$

$$\theta f_{ez}(x) K_{sd} - \zeta f'_m(x) - (\beta f_{ey}(x) - \mu \nu f_{hx}(x)) K_{cp} = 0, \quad (24)$$

$$- f'_{ez}(x) - \zeta \theta f'_m(x) K_{cd} + (\beta f_{ex}(x) + \mu \nu f_{hy}(x)) K_{cp} = 0, \quad (25)$$

$$f'_{ey}(x) - \theta f_{ex}(x) K_{sd} + (\mu \nu f_{hz}(x) - \beta \zeta f'_m(x)) K_{sp} = 0, \quad (26)$$

$$- f'_{ex}(x) - \theta f_{ey}(x) K_{cd} - \beta f_{ez}(x) K_{sp} + (\rho_o / \epsilon) \Xi(x) = 0, \quad (27)$$

$$f'_{hx}(x) + \theta f_{hy}(x) K_{sd} + \beta f_{hz}(x) K_{sp} - (\sigma_o / \mu) \Xi(x) = 0. \quad (28)$$

This is a system of 8 differential equations with 8 unknown functions (15).

Let us proceed with finding the solution. For this purpose we shall present this system in the following form:

$$S \cdot q + R \cdot \frac{dq}{dx} = Q \Xi(x), \quad (30)$$

where

$$q = \begin{bmatrix} f_{ex}(x) \\ f_{ey}(x) \\ f_{ez}(x) \\ f_{hx}(x) \\ f_{hy}(x) \\ f_{hz}(x) \\ f_{\varphi}(x) \\ f_{\phi}(x) \end{bmatrix}, \quad \frac{dq}{dx} = \begin{bmatrix} \partial f_{ex}(x) / \partial x \\ \partial f_{ey}(x) / \partial x \\ \partial f_{ez}(x) / \partial x \\ \partial f_{hx}(x) / \partial x \\ \partial f_{hy}(x) / \partial x \\ \partial f_{hz}(x) / \partial x \\ \partial f_{\varphi}(x) / \partial x \\ \partial f_{\phi}(x) / \partial x \end{bmatrix}, \quad (31)$$

$$S = \begin{bmatrix} -\varepsilon\omega K_{cp} & 0 & 0 & 0 & -\beta K_{cp} & \theta K_{cd} & 0 & 0 \\ 0 & -\varepsilon\omega K_{cp} & 0 & \beta K_{cp} & 0 & 0 & \theta\eta K_{sd} & 0 \\ 0 & 0 & -\varepsilon\omega K_{sp} & -\theta K_{cd} & 0 & 0 & \beta\eta K_{sp} & 0 \\ 0 & -\beta K_{cp} & \theta K_{sd} & -\mu\omega K_{cp} & 0 & 0 & 0 & 0 \\ \beta K_{cp} & 0 & 0 & 0 & \mu\omega K_{cp} & 0 & 0 & -\zeta\theta K_{cd} \\ -\theta K_{sd} & 0 & 0 & 0 & 0 & \mu\omega K_{sp} & 0 & -\beta\zeta K_{sp} \\ 0 & -\theta K_{cd} & -\beta K_{sp} & 0 & 0 & 0 & 0 & 0 \\ 0 & 0 & 0 & 0 & \theta K_{sd} & \beta K_{sp} & 0 & 0 \end{bmatrix}, \quad (32)$$

$$R = \begin{bmatrix} 0 & 0 & 0 & 0 & 0 & 0 & \eta & 0 \\ 0 & 0 & 0 & 0 & 0 & -1 & 0 & 0 \\ 0 & 0 & 0 & 0 & 1 & 0 & 0 & 0 \\ 0 & 0 & 0 & 0 & 0 & 0 & 0 & -\zeta \\ 0 & 0 & -1 & 0 & 0 & 0 & 0 & 0 \\ 0 & 1 & 0 & 0 & 0 & 0 & 0 & 0 \\ -1 & 0 & 0 & 0 & 0 & 0 & 0 & 0 \\ 0 & 0 & 0 & 1 & 0 & 0 & 0 & 0 \end{bmatrix}, \quad Q = \begin{bmatrix} 0 \\ 0 \\ 0 \\ 0 \\ 0 \\ 0 \\ -\rho_o/\mu \\ \sigma_o/\mu \end{bmatrix}. \quad (33)$$

Let us find

$$R^{-1} = \begin{bmatrix} 0 & 0 & 0 & 0 & 0 & 0 & -1 & 0 \\ 0 & 0 & 0 & 0 & 0 & 1 & 0 & 0 \\ 0 & 0 & 0 & 0 & -1 & 0 & 0 & 0 \\ 0 & 0 & 0 & 0 & 0 & 0 & 0 & 1 \\ 0 & 0 & 1 & 0 & 0 & 0 & 0 & 0 \\ 0 & -1 & 0 & 0 & 0 & 0 & 0 & 0 \\ 1/\eta & 0 & 0 & 0 & 0 & 0 & 0 & 0 \\ 0 & 0 & 0 & -1/\zeta & 0 & 0 & 0 & 0 \end{bmatrix}. \quad (34)$$

The equations system (30) may be rewritten in the following form

$$R^{-1} \cdot S \cdot q + \frac{dq}{dx} = R^{-1} \cdot Q \Xi(x) \quad (35)$$

or

$$S_1 q + \frac{dq}{dx} = Q_1 \Xi(x) \quad (36)$$

where

$$S_1 = R^{-1} S =$$

$$= \begin{bmatrix} 0 & \theta K_{cd} & \beta K_{sp} & 0 & 0 & 0 & 0 & 0 \\ -\theta K_{sd} & 0 & 0 & 0 & 0 & \mu \omega K_{sp} & 0 & -\beta \zeta K_{sp} \\ -\beta K_{cp} & 0 & 0 & 0 & -\mu \omega K_{cp} & 0 & 0 & \zeta \theta K_{cd} \\ 0 & 0 & 0 & 0 & \theta K_{sd} & \beta K_{sp} & 0 & 0 \\ 0 & 0 & -\varepsilon \omega K_{sp} & -\theta K_{cd} & 0 & 0 & \beta \eta K_{sp} & 0 \\ 0 & \varepsilon \omega K_{cp} & 0 & -\beta K_{cp} & 0 & 0 & -\theta \eta K_{sd} & 0 \\ -\varepsilon \omega K_{cp} / \eta & 0 & 0 & 0 & -\beta K_{cp} / \eta & \theta K_{cd} / \eta & 0 & 0 \\ 0 & \beta K_{cp} / \zeta & -\theta K_{sd} / \zeta & \mu \omega K_{cp} / \zeta & 0 & 0 & 0 & 0 \end{bmatrix}, \quad (37)$$

$$Q_1 = R^{-1}Q = \begin{bmatrix} \rho_o/\varepsilon \\ 0 \\ 0 \\ \sigma_o/\mu \\ 0 \\ 0 \\ 0 \\ 0 \end{bmatrix}. \quad (38)$$

From this we find:

$$\frac{dq}{dx} = -S_1q + Q_1\Xi(x), \quad (39)$$

$$q(x) = \int_0^x \frac{dq(\tau)}{d\tau} d\tau. \quad (40)$$

The parameters  $\eta, \zeta$ , generally speaking, may become equal to zero.

To avoid division by zero ( which may occur in the matrix  $S_1$ ), vector  $\frac{dq(x)}{dx}$  will be determined and denoted as

$$u(x) = \begin{bmatrix} \partial f_{ex}(x)/\partial x \\ \partial f_{ey}(x)/\partial x \\ \partial f_{ez}(x)/\partial x \\ \partial f_{hx}(x)/\partial x \\ \partial f_{hy}(x)/\partial x \\ \partial f_{hz}(x)/\partial x \\ \eta \cdot \partial f_{\phi}(x)/\partial x \\ \zeta \cdot \partial f_{\phi}(x)/\partial x \end{bmatrix}, \quad (41)$$

Then matrix  $S_1$  will assume the form

$$S_{10} = \begin{bmatrix} 0 & \theta K_{cd} & \beta K_{sp} & 0 & 0 & 0 & 0 & 0 \\ -\theta K_{sd} & 0 & 0 & 0 & 0 & \mu \omega K_{sp} & 0 & -\beta \zeta K_{sp} \\ -\beta K_{cp} & 0 & 0 & 0 & -\mu \omega K_{cp} & 0 & 0 & \zeta \theta K_{cd} \\ 0 & 0 & 0 & 0 & \theta K_{sd} & \beta K_{sp} & 0 & 0 \\ 0 & 0 & -\varepsilon \omega K_{sp} & -\theta K_{cd} & 0 & 0 & \beta \eta K_{sp} & 0 \\ 0 & \varepsilon \omega K_{cp} & 0 & -\beta K_{cp} & 0 & 0 & -\theta \eta K_{sd} & 0 \\ -\varepsilon \omega K_{cp} & 0 & 0 & 0 & -\beta K_{cp} & \theta K_{cd} & 0 & 0 \\ 0 & \beta K_{cp} & -\theta K_{sd} & \mu \omega K_{cp} & 0 & 0 & 0 & 0 \end{bmatrix} \quad (42)$$

and formula (39) will be transformed into

$$u(x) = -S_{10}q(x) + Q_1 \Xi(x), \quad (43)$$

But now the formula (analytical) integration (40) should be performed as follows: for the first 6 components – using the usual formula

$$q_k(x) = \int_0^x u_k(\tau) d\tau, \quad k = 1, 2, \dots, 6. \quad (44)$$

and for the last two components – using the following rule:

$$q_7(x) = \bar{\eta} \cdot \frac{1}{\eta} \int_0^x u_7(\tau) d\tau, \quad (45)$$

$$q_8(x) = \bar{\zeta} \cdot \frac{1}{\zeta} \int_0^x u_8(\tau) d\tau, \quad (46)$$

where

$$\bar{\eta} = \begin{cases} 1, & \text{if } \eta > 0, \\ 0, & \text{if } \eta = 0, \end{cases}, \quad \bar{\zeta} = \begin{cases} 1, & \text{if } \zeta > 0, \\ 0, & \text{if } \zeta = 0, \end{cases}, \quad (47)$$

In future such integration will be denoted as

$$q(x) = \int_0^x u(\tau) d\tau. \quad (48)$$

If functions  $\frac{dq(x)}{dx}$ ,  $q(x)$  on the  $n$ -th iteration are presented as the series

$$\frac{dq}{dx} = u = \sum_{k=1}^n u_k, \quad q = \sum_{k=1}^n q_k, \quad (49)$$

then, in accordance with algorithms 6.7 and (43, 48), on the  $(n + 1)$ -th iteration, where  $x > 0$ , we shall have:

$$u_{n+1}(x) = -S_{10}q_n(x), \quad (50)$$

$$q_{n+1}(x) = \int_0^x u_{n+1}(\tau) \cdot d\tau. \quad (51)$$

## 9.2. Examples of Functions Chp(w), Chd(w), Shp(w), Shd(w)

Here we shall show several functions satisfying the conditions (1.11-1.14). For  $k_{sp} = k_{sd} = k_{cp} = k_{cd} = 1$  the conditions (1.11-1.14) are satisfied, for instance, by functions

$$\begin{aligned} \text{Chp}(w) &= e^w, \text{Chd}(w) = e^w, \\ \text{Shp}(w) &= e^w, \text{Shd}(w) = e^w \end{aligned} \quad (1)$$

or

$$\begin{aligned} \text{Chp}(w) &= \text{ch}(w), \text{Chd}(w) = e^w, \\ \text{Shp}(w) &= \text{sh}(w), \text{Shd}(w) = e^w \end{aligned} \quad (2)$$

or

$$\begin{aligned} \text{Chp}(w) &= \text{ch}(w), \text{Chd}(w) = \text{ch}(w), \\ \text{Shp}(w) &= \text{sh}(w), \text{Shd}(w) = \text{sh}(w) \end{aligned} \quad (3)$$

For  $k_{sp} = k_{sd} = 1$ ,  $k_{cp} = k_{cd} = -1$  the conditions (1.11-1.14) are met, for instance, by functions

$$\begin{aligned} \text{Chp}(w) &= \cos(w), \text{Chd}(w) = \cos(w), \\ \text{Shp}(w) &= \sin(w), \text{Shd}(w) = \sin(w) \end{aligned} \quad (4)$$

### 9.3. Using the method for $\Xi(x) = \lambda'(x)$ и $k_{sp} = k_{sd} = k_{cp} = k_{cd} = 1$ .

In this section we are discussing the function  $\Xi(x) = \lambda'(x)$

#### 9.3.1. The general solution

The matrix (1.42) will take the form

$$S_{10} = \begin{bmatrix} 0 & \theta & \beta & 0 & 0 & 0 & 0 & 0 \\ -\theta & 0 & 0 & 0 & 0 & \mu\omega & 0 & -\beta\zeta \\ -\beta & 0 & 0 & 0 & -\mu\omega & 0 & 0 & \theta\zeta \\ 0 & 0 & 0 & 0 & \theta & \beta & 0 & 0 \\ 0 & 0 & -\varepsilon\omega & -\theta & 0 & 0 & \beta\eta & 0 \\ 0 & \varepsilon\omega & 0 & -\beta & 0 & 0 & -\theta\eta & 0 \\ -\varepsilon\omega & 0 & 0 & 0 & -\beta & \theta & 0 & 0 \\ 0 & \beta & -\theta & \mu\omega & 0 & 0 & 0 & 0 \end{bmatrix} \quad (1)$$

Let us consider, according to algorithm 6.7 and formulas (1.43, 1.48) the iteration process, assuming that  $q_0(x) = 0$ .

$$\begin{aligned} u_1(x) = Q_1 = q_1(x) = & \quad u_2(x) = & \quad q_2(x) = \\ = \lambda' \begin{bmatrix} \rho_o/\varepsilon \\ 0 \\ 0 \\ \sigma_o/\mu \\ 0 \\ 0 \\ 0 \\ 0 \\ 0 \end{bmatrix}, & \quad = \lambda \begin{bmatrix} \rho_o/\varepsilon \\ 0 \\ 0 \\ \sigma_o/\mu \\ 0 \\ 0 \\ 0 \\ 0 \\ 0 \end{bmatrix}, & \quad = \lambda \begin{bmatrix} 0 \\ \theta\rho_o/\varepsilon \\ \beta\rho_o/\varepsilon \\ 0 \\ \theta\sigma_o/\mu \\ \beta\sigma_o/\mu \\ \omega\rho_o/\eta \\ -\omega\sigma_o/\zeta \end{bmatrix}, & \quad = x \begin{bmatrix} 0 \\ \theta\rho_o/\varepsilon \\ \beta\rho_o/\varepsilon \\ 0 \\ \theta\sigma_o/\mu \\ \beta\sigma_o/\mu \\ \omega\rho_o/\eta \\ -\omega\sigma_o/\zeta \end{bmatrix}. \end{aligned}$$

$$u_3(x) = x \begin{bmatrix} -(\theta^2 + \beta^2) \rho_o / \varepsilon \\ -(1 - \bar{\eta}) \omega \beta \sigma_o \\ (1 - \bar{\eta}) \omega \theta \sigma_o \\ -(\theta^2 + \beta^2) \sigma_o / \mu \\ (1 - \bar{\zeta}) \omega \beta \rho_o \\ -(1 - \bar{\zeta}) \omega \theta \rho_o \\ 0 \\ 0 \end{bmatrix}, \quad q_3(x) = \frac{x^2}{2} \begin{bmatrix} -(\theta^2 + \beta^2) \rho_o / \varepsilon \\ -(1 - \bar{\eta}) \omega \beta \sigma_o \\ (1 - \bar{\eta}) \omega \theta \sigma_o \\ -(\theta^2 + \beta^2) \sigma_o / \mu \\ (1 - \bar{\zeta}) \omega \beta \rho_o \\ -(1 - \bar{\zeta}) \omega \theta \rho_o \\ 0 \\ 0 \end{bmatrix}.$$

$$u_4(x) = \frac{x^2}{2} \begin{bmatrix} 0 \\ -\theta(\theta^2 + \beta^2) \rho_o / \varepsilon \\ -\beta(\theta^2 + \beta^2) \rho_o / \varepsilon \\ 0 \\ -\theta(\theta^2 + \beta^2) \sigma_o / \mu \\ -\beta(\theta^2 + \beta^2) \sigma_o / \mu \\ -\omega \eta(\theta^2 + \beta^2) \rho_o \\ \omega \zeta(\theta^2 + \beta^2) \sigma_o \end{bmatrix}, \quad q_4(x) = \frac{x^3}{2 \cdot 3} \begin{bmatrix} 0 \\ -\theta(\theta^2 + \beta^2) \rho_o / \varepsilon \\ -\beta(\theta^2 + \beta^2) \rho_o / \varepsilon \\ 0 \\ -\theta(\theta^2 + \beta^2) \sigma_o / \mu \\ -\beta(\theta^2 + \beta^2) \sigma_o / \mu \\ -\omega \eta(\theta^2 + \beta^2) \rho_o \\ \omega \zeta(\theta^2 + \beta^2) \sigma_o \end{bmatrix}.$$

$$u_5(x) = \frac{x^3}{2 \cdot 3} \begin{bmatrix} (\theta^2 + \beta^2) \rho_o / \varepsilon \\ (1 - \bar{\eta}) \omega \beta (\theta^2 + \beta^2) \sigma_o \\ -(1 - \bar{\eta}) \omega \theta (\theta^2 + \beta^2) \sigma_o \\ (\theta^2 + \beta^2) \sigma_o / \mu \\ (1 - \bar{\zeta}) \omega \beta (\theta^2 + \beta^2) \rho_o \\ -(1 - \bar{\zeta}) \omega \theta (\theta^2 + \beta^2) \rho_o \\ 0 \\ 0 \end{bmatrix}, \quad q_5(x) = \frac{x^4}{2 \cdot 3 \cdot 4} \begin{bmatrix} (\theta^2 + \beta^2) \rho_o / \varepsilon \\ (1 - \bar{\eta}) \omega \beta (\theta^2 + \beta^2) \sigma_o \\ -(1 - \bar{\eta}) \omega \theta (\theta^2 + \beta^2) \sigma_o \\ (\theta^2 + \beta^2) \sigma_o / \mu \\ (1 - \bar{\zeta}) \omega \beta (\theta^2 + \beta^2) \rho_o \\ -(1 - \bar{\zeta}) \omega \theta (\theta^2 + \beta^2) \rho_o \\ 0 \\ 0 \end{bmatrix}.$$

And so on. Continuing the iterations, we may notice the following pattern in iterations with odd numbers

$$u_1(x) = \frac{\rho_o}{\varepsilon} (\lambda'(x) + r_1(x)), \quad q_1(x) = \frac{\rho_o}{\varepsilon} (\lambda(x) + r_2(x)),$$

$$u_4(x) = \frac{\sigma_o}{\mu} (\lambda'(x) + r_1(x)), \quad q_4(x) = \frac{\sigma_o}{\mu} (\lambda(x) + r_2(x)),$$



$$\begin{aligned}
 u_2(x) &= (1 - \bar{\eta})\omega\beta\sigma_o r_3(x), & q_2(x) &= (1 - \bar{\eta})\omega\beta\sigma_o r_4(x), \\
 u_3(x) &= -(1 - \bar{\eta})\omega\theta\sigma_o r_3(x), & q_3(x) &= -(1 - \bar{\eta})\omega\theta\sigma_o r_4(x), \\
 u_5(x) &= -(1 - \bar{\zeta})\omega\beta\rho_o r_3(x), & q_5(x) &= -(1 - \bar{\zeta})\omega\beta\rho_o r_4(x), \\
 u_6(x) &= (1 - \bar{\zeta})\omega\theta\rho_o r_3(x), & q_6(x) &= (1 - \bar{\zeta})\omega\theta\rho_o r_4(x),
 \end{aligned}$$

and in iterations with even numbers

$$u(x) = u_{20}(\lambda(x) + r_4(x)), \quad q(x) = u_{20}r_3(x),$$

where

$$u_{20} = \begin{bmatrix} 0 \\ \theta\rho_o/\varepsilon \\ \beta\rho_o/\varepsilon \\ 0 \\ \theta\sigma_o/\mu \\ \beta\sigma_o/\mu \\ \bar{\eta}\omega\rho_o/\eta \\ -\bar{\zeta}\omega\sigma_o/\zeta \end{bmatrix},$$

and the series are:

$$\begin{aligned}
 r_1(x) &= \left( -x(\theta^2 + \beta^2) + \frac{x^3}{2 \cdot 3}(\theta^2 + \beta^2) - \dots \right), \\
 r_2(x) &= \left( -\frac{x^2}{2}(\theta^2 + \beta^2) + \frac{x^4}{2 \cdot 3 \cdot 4}(\theta^2 + \beta^2) - \dots \right), \\
 r_3(x) &= \left( -x + \frac{x^3}{2 \cdot 3}(\theta^2 + \beta^2) - \dots \right), \\
 r_4(x) &= \left( -\frac{x^2}{2} + \frac{x^4}{2 \cdot 3 \cdot 4}(\theta^2 + \beta^2) - \dots \right),
 \end{aligned}$$

Continuing the iterations, we may see that these series are power series of trigonometric functions, namely:

$$\begin{aligned}
 r_1(x) &= -\chi \sin(\chi \cdot x), & r_2(x) &= (-1 + \cos(\chi \cdot x)), \\
 r_3(x) &= \frac{-1}{\chi} \sin(\chi \cdot x), & r_4(x) &= \frac{1}{\chi^2} (-1 + \cos(\chi \cdot x)),
 \end{aligned}$$

where

$$\chi = \sqrt{\left(\theta^2 + \beta^2\right)}. \quad (2)$$

So, in the iterations with odd numbers

$$u_1(x) = \frac{\rho_o}{\varepsilon} (\lambda'(x) - \chi \sin(\chi \cdot x)), \quad q_1(x) = \frac{\rho_o}{\varepsilon} (\lambda(x) - 1 + \cos(\chi \cdot x)),$$

$$u_4(x) = \frac{\sigma_o}{\mu} (\lambda'(x) - \chi \sin(\chi \cdot x)), \quad q_4(x) = \frac{\sigma_o}{\mu} (\lambda(x) - 1 + \cos(\chi \cdot x)),$$

$$u_2(x) = (1 - \bar{\eta}) \frac{\omega\beta\sigma_o}{\chi} (-\sin(\chi \cdot x)), \quad q_2(x) = (1 - \bar{\eta}) \frac{\omega\beta\sigma_o}{\chi^2} (-1 + \cos(\chi \cdot x)),$$

$$u_3(x) = -(1 - \bar{\eta}) \frac{\omega\beta\sigma_o}{\chi} (-\sin(\chi \cdot x)), \quad q_3(x) = -(1 - \bar{\eta}) \frac{\omega\beta\sigma_o}{\chi^2} (-1 + \cos(\chi \cdot x)),$$

$$u_5(x) = -(1 - \bar{\zeta}) \frac{\omega\beta\rho_o}{\chi} (-\sin(\chi \cdot x)), \quad q_5(x) = -(1 - \bar{\zeta}) \frac{\omega\beta\rho_o}{\chi^2} (-1 + \cos(\chi \cdot x)),$$

$$u_6(x) = -(1 - \bar{\zeta}) \frac{\omega\beta\rho_o}{\chi} (-\sin(\chi \cdot x)), \quad q_6(x) = -(1 - \bar{\zeta}) \frac{\omega\beta\rho_o}{\chi^2} (-1 + \cos(\chi \cdot x)),$$

and in iterations with even numbers

$$u(x) = u_{20}(\lambda(x) - 1 + \cos(\chi \cdot x)), \quad q(x) = u_{20} \left( \frac{1}{\chi} \sin(\chi \cdot x) \right).$$

Hence, the solution is as follows:

$$q = \left[ \begin{array}{l} f_{ex}(x) = e_x(\lambda(x) - 1 + \cos(\chi x)) \\ f_{ey}(x) = e'_y \sin(\chi x) + e''_y(-1 + \cos(\chi x)) \\ f_{ez}(x) = e'_z \sin(\chi x) - e''_z(-1 + \cos(\chi x)) \\ f_{hx}(x) = h_x(\lambda(x) - 1 + \cos(\chi x)) \\ f_{hy}(x) = h'_y \sin(\chi x) - h''_y(-1 + \cos(\chi x)) \\ f_{hz}(x) = h'_z \sin(\chi x) + h''_z(-1 + \cos(\chi x)) \\ f_\varphi(x) = \varphi_x \sin(\chi x) \\ f_\phi(x) = \phi_x \sin(\chi x) \end{array} \right], \quad (3)$$

$$\frac{dq}{dx} = \begin{bmatrix} \partial f_{ex}(x) / \partial x = e_x (\lambda'(x) - \chi \sin(\chi x)) \\ \partial f_{ey}(x) / \partial x = \chi e'_y (\lambda(x) - 1 + \cos(\chi x)) - \chi e''_y \sin(\chi x) \\ \partial f_{ez}(x) / \partial x = \chi e'_z (\lambda(x) - 1 + \cos(\chi x)) + \chi e''_z \sin(\chi x) \\ \partial f_{hx}(x) / \partial x = h_x (\lambda'(x) - \chi \sin(\chi x)) \\ \partial f_{hy}(x) / \partial x = \chi h'_y (\lambda(x) - 1 + \cos(\chi x)) + \chi h''_y \sin(\chi x) \\ \partial f_{hz}(x) / \partial x = \chi h'_z (\lambda(x) - 1 + \cos(\chi x)) - \chi h''_z \sin(\chi x) \\ \partial f_\phi(x) / \partial x = -\chi \phi_x (\lambda(x) - 1 + \cos(\chi x)) \\ \partial f_\phi(x) / \partial x = -\chi \phi_x (\lambda(x) - 1 + \cos(\chi x)) \end{bmatrix}. \quad (4)$$

Coefficients in (3, 4) are enumerated in the Table. 1. There it is specified, which coefficients are absent in certain media in the presence of certain charges. In vacuum  $\eta = 0$ ,  $\zeta = 0$  and, in accordance with (1.47)  $\bar{\zeta} = 0$ ,  $\bar{\eta} = 0$ . In normal medium  $\zeta = 0$   $\bar{\zeta} = 0$ .

It is easy to see that presence or absence of coefficients  $e$ ,  $h$  does not depend on the type of medium is being considered – vacuum or normal medium. If there are both electric and magnetic charges, all the coefficients  $e$ ,  $h$  are present.

In particular, if  $x = 0$ , from (3, 4) we have:

$$q = \begin{bmatrix} f_{ex}(x) = e_x \\ f_{ey}(x) = 0 \\ f_{ez}(x) = 0 \\ f_{hx}(x) = h_x \\ f_{hy}(x) = 0 \\ f_{hz}(x) = 0 \\ f_\phi(x) = 0 \\ f_\phi(x) = 0 \end{bmatrix}, \quad \frac{dq}{dx} = \begin{bmatrix} \partial f_{ex}(x) / \partial x = (\rho_o / \varepsilon) \lambda'(0) \\ \partial f_{ey}(x) / \partial x = 0 \\ \partial f_{ez}(x) / \partial x = 0 \\ \partial f_{hx}(x) / \partial x = (\sigma_o / \mu) \lambda'(0) \\ \partial f_{hy}(x) / \partial x = 0 \\ \partial f_{hz}(x) / \partial x = 0 \\ \partial f_\phi(x) / \partial x = 0 \\ \partial f_\phi(x) / \partial x = 0 \end{bmatrix}. \quad (5)$$

Table 1.

| Coefficients   | Vacuum                |                       | Normal medium         |                       |
|--|-----------------------|-----------------------|-----------------------|-----------------------|
|  | Only electric charges | Only magnetic charges | Only electric charges | Only magnetic charges |
| $e_x = \rho_o / \varepsilon$                                 | +                     | 0                     | +                     | 0                     |
| $e'_y = \theta \rho_o / \varepsilon \chi$                    | +                     | 0                     | +                     | 0                     |
| $e''_y = (1 - \bar{\eta}) (\omega \beta \sigma_o / \chi^2)$  | 0                     | +                     | 0                     | +                     |
| $e'_z = \beta \rho_o / \varepsilon \chi$                     | +                     | 0                     | +                     | 0                     |
| $e''_z = (1 - \bar{\eta}) (\omega \theta \sigma_o / \chi^2)$ | 0                     | +                     | 0                     | +                     |
| $h_x = \sigma_o / \mu$                                       | 0                     | +                     | 0                     | +                     |
| $h'_y = \theta \sigma_o / \mu \chi$                          | 0                     | +                     | 0                     | +                     |
| $h''_y = (1 - \bar{\zeta}) (\omega \beta \rho_o / \chi^2)$   | +                     | 0                     | +                     | 0                     |
| $h'_z = \beta \sigma_o / \mu \chi$                           | 0                     | +                     | 0                     | +                     |
| $h''_z = (1 - \bar{\zeta}) (\omega \beta \rho_o / \chi^2)$   | +                     | 0                     | +                     | 0                     |
| $\varphi_x = \bar{\eta} (\omega \rho_o / \eta \chi)$         | +                     | 0                     | +                     | 0                     |
| $\phi_x = -\bar{\zeta} (\omega \sigma_o / \zeta \chi)$       | 0                     | +                     | 0                     | 0                     |

Thus, при the solution of differential equations with disturbances in the form of Dirac functions  $\lambda'(x)$ , the obtained functions and their derivatives may contain a variable component, a step component  $\lambda(x)$ , a Dirac function  $\lambda'(x)$  and a constant component.

We shall solve this problem directly as the equation (1.36). An example of solving equation (1.36) for  $\theta = 90$ ,  $\beta = 110$ ,  $\omega = 1000$ ,  $\sigma_o = -0.25$ ,  $\rho_o = 10^{-7}$  is shown on Fig. 9.3.1. Fig. 9.3.1a shows the graphs of sought functions, Fig. 9.3.1b – graphs of these functions' derivatives, and Fig. 9.3.1c – graphs of residuals in the equations (1.36). The types of graphs are shown in the figures. The function used in the calculations is also indicated there, as well as the values of some parameters of this function, which appear in the captions under the figures ( these remarks will apply also to other figures of this section).

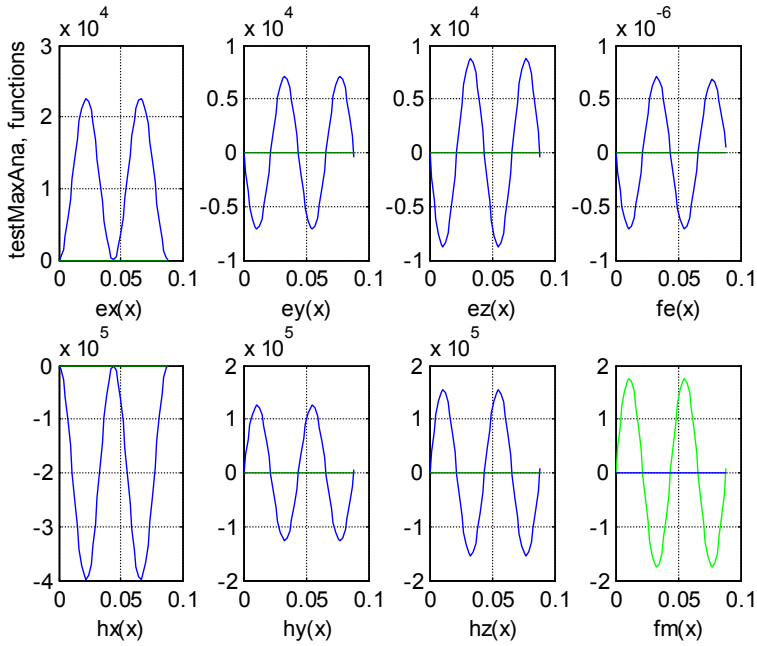

Fig. 9.3.1a. The general solution for  $\Xi(x) = \lambda'(x)$ ,  $k_{sp} = k_{sd} = k_{cp} = k_{cd} = 1$ , mode=1, modeZ=2, modeFig=1.

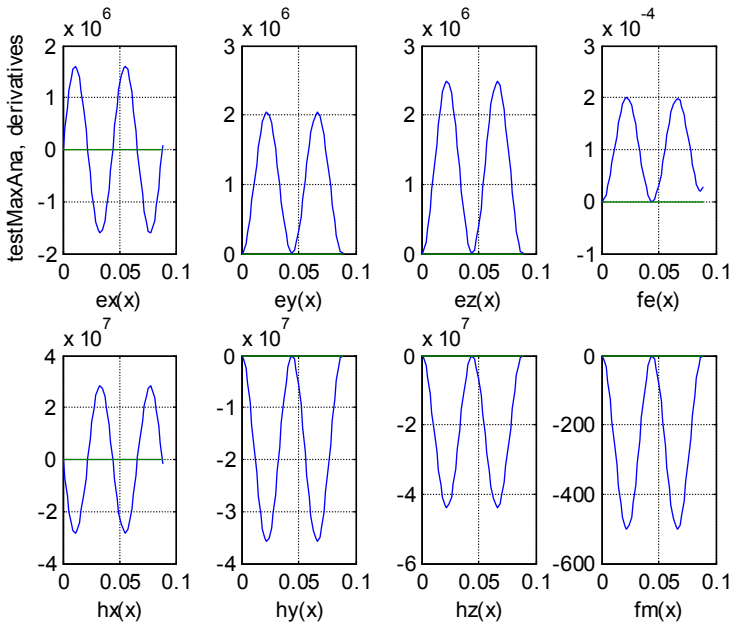

Fig. 9.3.1b, modeFig=2.

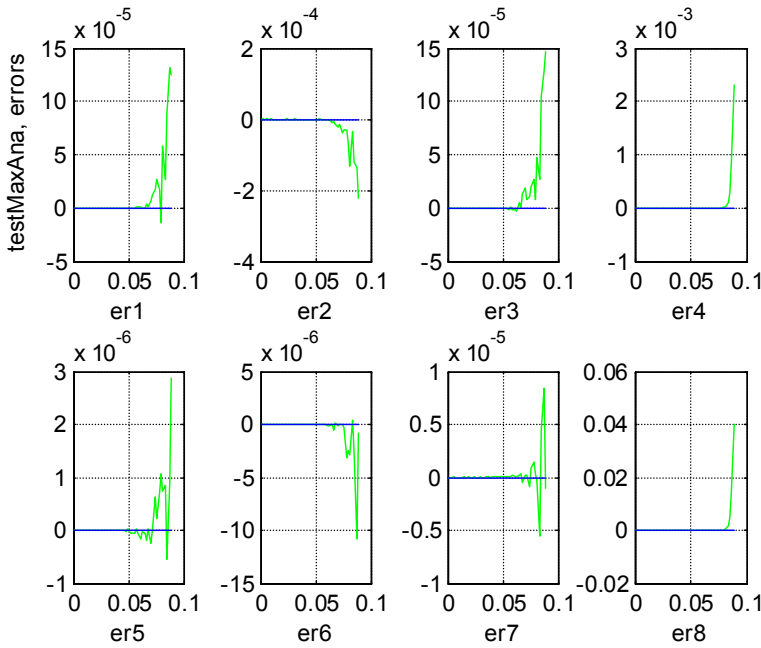

Fig. 9.3.1c, modeFig=3.

In the solution of differential equations with disturbances in the form of Dirac functions  $\lambda'(x)$ , the obtained functions and their derivatives may contain a variable component, a step component  $\lambda(x)$ , a Dirac function  $\lambda'(x)$  and a constant component.

Let us solve this problem directly as the equation (1.36) – see the function testMaxAna. The example of solving this equation for  $\theta = 90$ ,  $\beta = 110$ ,  $\omega = 1000$ ,  $\sigma_o = -0.25$ ,  $\rho_o = 10^{-7}$  is given on Fig. 9.3.1. The Fig 9.3.1a shows the graphs of the unknown functions, Fig. 9.3.1b – the graphs of their derivatives and Fig. 9.3.1c –graphs of the residuals in equations (1.36). The types of these graphs is shown in the pictures. There are also shown the functions used for and in the captions there are also some values of this function's parameters (the same remarks will be true for other figures in this section).

### 9.3.2. Solution in the medium without scalar magnetic potential - $\zeta = 0$

Above in general case we were dealing with a hypothetic medium, in which both electric and magnetic scalar potentials may be present, as well as electric and magnetic currents. In a medium without scalar magnetic potential  $\zeta = 0$ , and in accordance with (1.47) -  $\bar{\zeta} = 0$ . According to Table 1 certain coefficients are absent.

#### 9.3.2.1. Magnetic charges in the medium without scalar magnetic potential

In this case (3, 4) take the form

$$q = \left[ \begin{array}{l} f_{ex}(x) = 0 \\ f_{ey}(x) = e_y''(-1 + \cos(\chi x)) \\ f_{ez}(x) = -e_z''(-1 + \cos(\chi x)) \\ f_{hx}(x) = h_x(\lambda(x) - 1 + \cos(\chi x)) \\ f_{hy}(x) = h_y' \sin(\chi x) \\ f_{hz}(x) = h_z' \sin(\chi x) \\ f_\varphi(x) = 0 \\ f_\phi(x) = 0 \end{array} \right], \quad (7)$$

$$\frac{dq}{dx} = \left[ \begin{array}{l} \partial f_{ex}(x) / \partial x = 0 \\ \partial f_{ey}(x) / \partial x = -\chi e_y'' \sin(\chi x) \\ \partial f_{ez}(x) / \partial x = \chi e_z'' \sin(\chi x) \\ \partial f_{hx}(x) / \partial x = h_x(\lambda'(x) - \chi \sin(\chi x)) \\ \partial f_{hy}(x) / \partial x = \chi h_y'(\lambda(x) - 1 + \cos(\chi x)) \\ \partial f_{hz}(x) / \partial x = \chi h_z'(\lambda(x) - 1 + \cos(\chi x)) \\ \partial f_\varphi(x) / \partial x = 0 \\ \partial f_\phi(x) / \partial x = 0 \end{array} \right]. \quad (8)$$

We shall solve this problem directly as the equation (1.36). To do this we shall discard the variable function  $f_\phi(x)$  and the equation (1.24) in the equation system (1.21-1.28). We shall begin to solve the system of the remaining 7 equations. Further we shall show that the equation (1.24) is fulfilled when the obtained solution is substituted to the full equations system. After the equation (1.24) is discarded, the vectors and matrices of equation (1.36) take the following form:

$$q = \begin{bmatrix} f_{ex}(x) \\ f_{ey}(x) \\ f_{ez}(x) \\ f_{hx}(x) \\ f_{hy}(x) \\ f_{hz}(x) \\ f_\phi(x) \end{bmatrix}, \quad \frac{dq}{dx} = \begin{bmatrix} \partial f_{ex}(x)/\partial x \\ \partial f_{ey}(x)/\partial x \\ \partial f_{ez}(x)/\partial x \\ \partial f_{hx}(x)/\partial x \\ \partial f_{hy}(x)/\partial x \\ \partial f_{hz}(x)/\partial x \\ \partial f_\phi(x)/\partial x \end{bmatrix}, \quad (9)$$

$$S = \begin{bmatrix} -\varepsilon\omega & 0 & 0 & 0 & -\beta & \theta & 0 \\ 0 & -\varepsilon\omega & 0 & \beta & 0 & 0 & \theta\eta \\ 0 & 0 & -\varepsilon\omega & -\theta & 0 & 0 & \beta\eta \\ 0 & 0 & 0 & 0 & \theta & \beta & 0 \\ \beta & 0 & 0 & 0 & \mu\omega & 0 & 0 \\ -\theta & 0 & 0 & 0 & 0 & \mu\omega & 0 \\ 0 & -\theta & -\beta & 0 & 0 & 0 & 0 \end{bmatrix}, \quad (10)$$

$$R = \begin{bmatrix} 0 & 0 & 0 & 0 & 0 & 0 & \eta \\ 0 & 0 & 0 & 0 & 0 & -1 & 0 \\ 0 & 0 & 0 & 0 & 1 & 0 & 0 \\ 0 & 0 & 0 & 1 & 0 & 0 & 0 \\ 0 & 0 & -1 & 0 & 0 & 0 & 0 \\ 0 & 1 & 0 & 0 & 0 & 0 & 0 \\ -1 & 0 & 0 & 0 & 0 & 0 & 0 \end{bmatrix}, \quad Q = \begin{bmatrix} 0 \\ 0 \\ 0 \\ \sigma_o/\mu \\ 0 \\ 0 \\ 0 \end{bmatrix}. \quad (11)$$

Here we have in mind the following order of equations: (21, 22, 23, 28, 25, 26, 27).



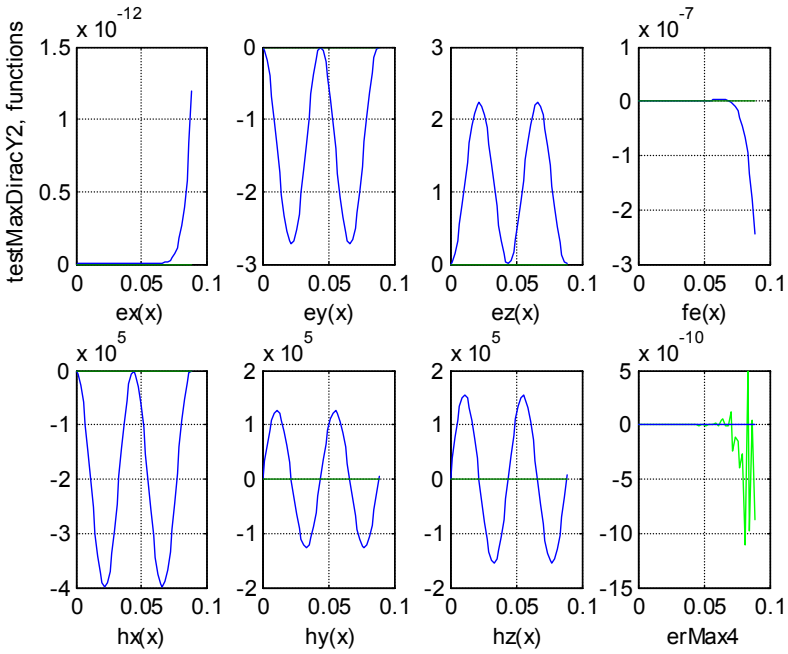

Fig. 9.3.2.1. Magnetic charges in the medium without scalar magnetic potential

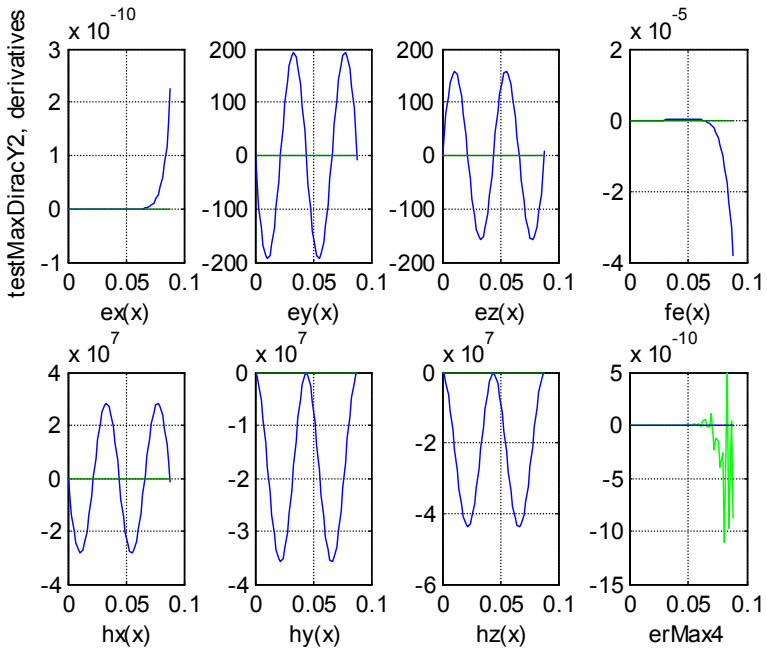

Fig. 9.3.2.1B.

An example of solving the equation (1.36) for  $\theta = 90$ ,  $\beta = 110$ ,  $\omega = 1000$ ,  $\sigma_o = -0.25$ ,  $\rho_o = 0$  is shown on Fig.

9.3.2.1 – see also function testMaxDiracY2. There for  $x > 0.06$  we see "spikes" of certain functions, which may be explained by methodical errors. In the last window in all three figures we observe the error (residue) in the condition (1.24), which was discarded above in order to eliminate overdetermination of the equation system. Thus we have also proved the relevance of this discarding. The figures show that the obtained solution is in accordance with analytical solution (7, 8).

### 9.3.2.2. Electrical charges in the medium without scalar magnetic potential.

In this case (3, 4) take the form:

$$q = \left[ \begin{array}{l} f_{ex}(x) = e_x(\lambda(x) - 1 + \cos(\chi x)) \\ f_{ey}(x) = e'_y \sin(\chi x) \\ f_{ez}(x) = e'_z \sin(\chi x) \\ f_{hx}(x) = 0 \\ f_{hy}(x) = -h''_y(-1 + \cos(\chi x)) \\ f_{hz}(x) = h''_z(-1 + \cos(\chi x)) \\ f_\varphi(x) = \varphi_x \sin(\chi x) \\ f_\phi(x) = 0 \end{array} \right], \quad (12)$$

$$\frac{dq}{dx} = \left[ \begin{array}{l} \partial f_{ex}(x) / \partial x = e_x(\lambda'(x) - \chi \sin(\chi x)) \\ \partial f_{ey}(x) / \partial x = \chi e'_y(\lambda(x) - 1 + \cos(\chi x)) \\ \partial f_{ez}(x) / \partial x = \chi e'_z(\lambda(x) - 1 + \cos(\chi x)) \\ \partial f_{hx}(x) / \partial x = 0 \\ \partial f_{hy}(x) / \partial x = \chi h''_y \sin(\chi x) \\ \partial f_{hz}(x) / \partial x = -\chi h''_z \sin(\chi x) \\ \partial f_\varphi(x) / \partial x = -\chi \varphi_x(\lambda(x) - 1 + \cos(\chi x)) \\ \partial f_\phi(x) / \partial x = 0 \end{array} \right]. \quad (13)$$

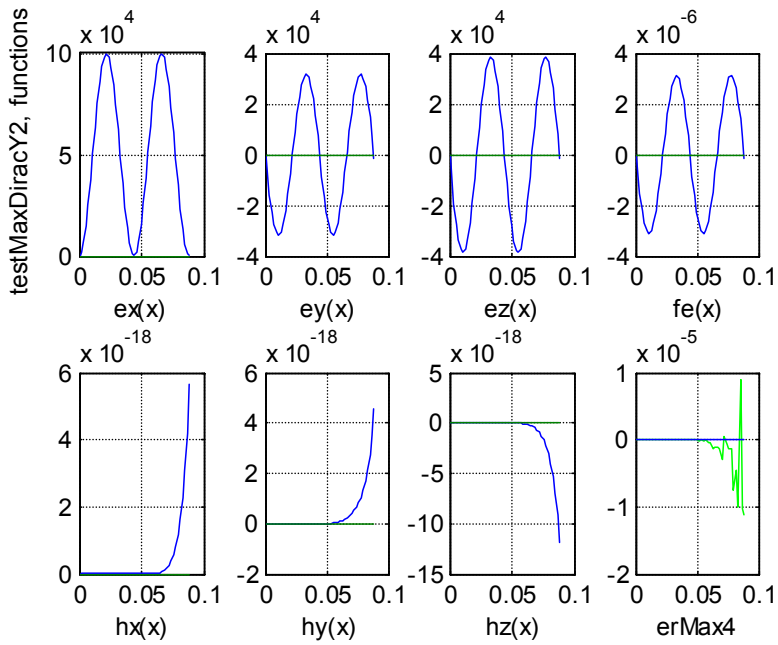

Fig. 9.3.2.2a. Electrical charges in the medium without scalar magnetic potential.

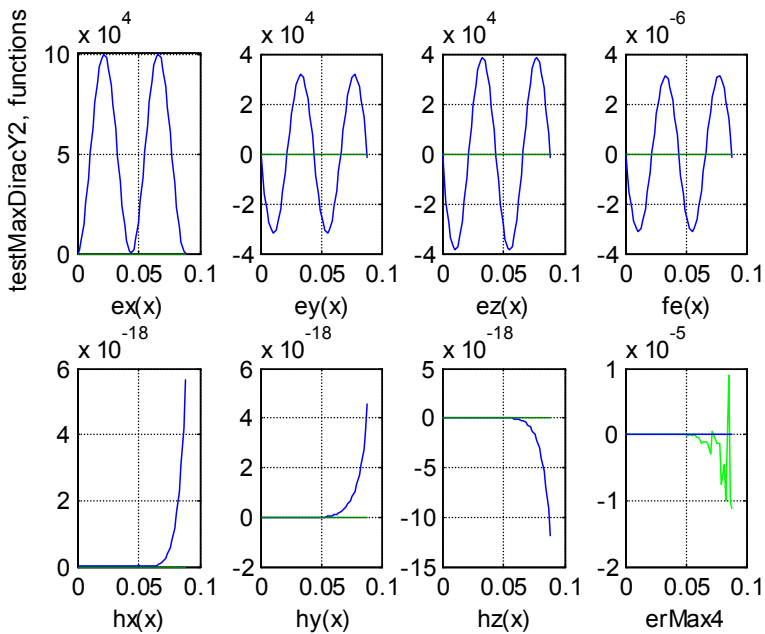

Fig. 9.3.2.2b.

As in the previous case we shall solve the same problem directly as the equation (1.36). An example of solving for  $\theta = 90$ ,  $\beta = 110$ ,  $\omega = 1000$ ,  $\sigma_o = 0$ ,  $\rho_o = 10^{-7}$  is shown on Fig. 9.3.2.2.

### 9.3.3. Solution in vacuum

To verify the solution (3, 4) we shall now solve the problem directly as the equation (1.36). To do this we shall discard the equations (1.21, 1.24) and variable functions  $f_\varphi(x), f_\phi(x)$  in the equations system (1.21-1.28). We shall solve a system of the remaining 6 equations. Then we shall show that the equations (1.21-1.28) are fulfilled at substitution of the obtained solution into the full system. After discarding the equations (1.21-1.28) vectors and matrices of the equation (1.36) take the following form:

$$q = \begin{bmatrix} f_{ex}(x) \\ f_{ey}(x) \\ f_{ez}(x) \\ f_{hx}(x) \\ f_{hy}(x) \\ f_{hz}(x) \end{bmatrix}, \quad \frac{dq}{dx} = \begin{bmatrix} \partial f_{ex}(x) / \partial x \\ \partial f_{ey}(x) / \partial x \\ \partial f_{ez}(x) / \partial x \\ \partial f_{hx}(x) / \partial x \\ \partial f_{hy}(x) / \partial x \\ \partial f_{hz}(x) / \partial x \end{bmatrix}, \quad (15)$$

$$S = \begin{bmatrix} 0 & -\theta & -\beta & 0 & 0 & 0 \\ 0 & -\varepsilon\omega & 0 & \beta & 0 & 0 \\ 0 & 0 & -\varepsilon\omega & -\theta & 0 & 0 \\ 0 & 0 & 0 & 0 & \theta & \beta \\ \beta & 0 & 0 & 0 & \mu\omega & 0 \\ -\theta & 0 & 0 & 0 & 0 & \mu\omega \end{bmatrix}, \quad (16)$$

$$R = \begin{bmatrix} -1 & 0 & 0 & 0 & 0 & 0 \\ 0 & 0 & 0 & 0 & 0 & -1 \\ 0 & 0 & 0 & 0 & 1 & 0 \\ 0 & 0 & 0 & 1 & 0 & 0 \\ 0 & 0 & -1 & 0 & 0 & 0 \\ 0 & 1 & 0 & 0 & 0 & 0 \end{bmatrix}, \quad Q = \begin{bmatrix} -\rho_o/\mu \\ 0 \\ 0 \\ \sigma_o/\mu \\ 0 \\ 0 \end{bmatrix}. \quad (17)$$

Here we are meaning the following order of equations: (1.27, 1.22, 1.23, 1.28, 1.25, 1.26).

### 9.3.3.1. Magnetic charges in vacuum

Let us first discuss the case when only magnetic charges are present – see also function `testMaxDiracY2e`. The solution is as follows (7, 8). An example of equation (1.36) solution for  $\theta = 90$ ,  $\beta = 110$ ,  $\omega = 1000$ ,  $\sigma_o = -0.25$ ,  $\rho_o = 0$  is shown on Fig. 9.3.3.1. There for  $x > 0.06$  we see "spikes" of certain functions, which may be explained by methodical errors. In the 4<sup>th</sup> and 8<sup>th</sup> window on all three figures we observe the error (residue) in the conditions (1.21) and (1.24), which were discarded above. Thus we have proved the relevance of this discarding.

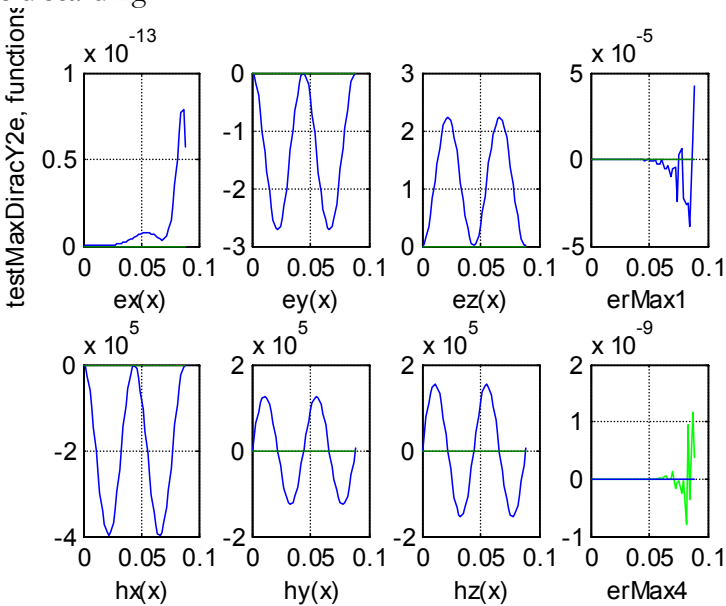

Fig.. 9.3.3.1a. Magnetic charges in vacuum.

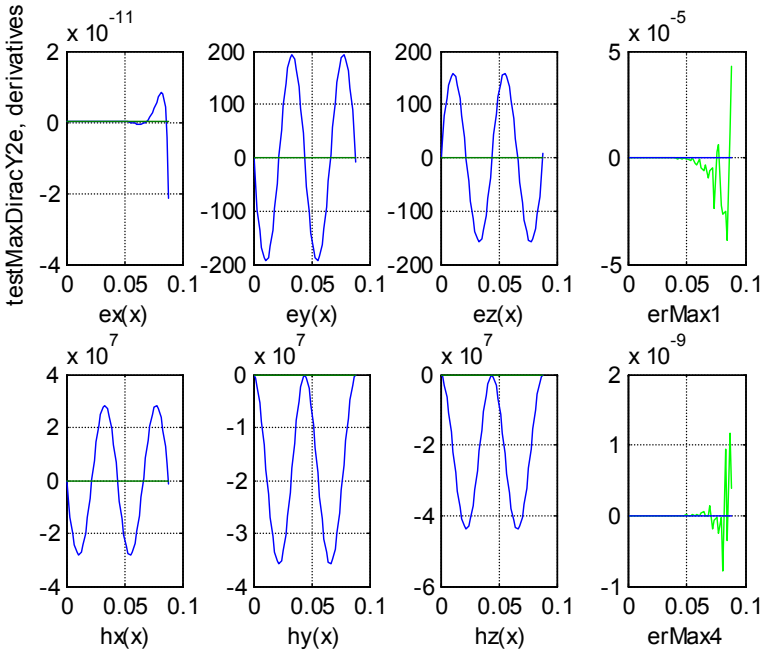

Fig. 9.3.3.1b. Magnetic charges in vacuum.

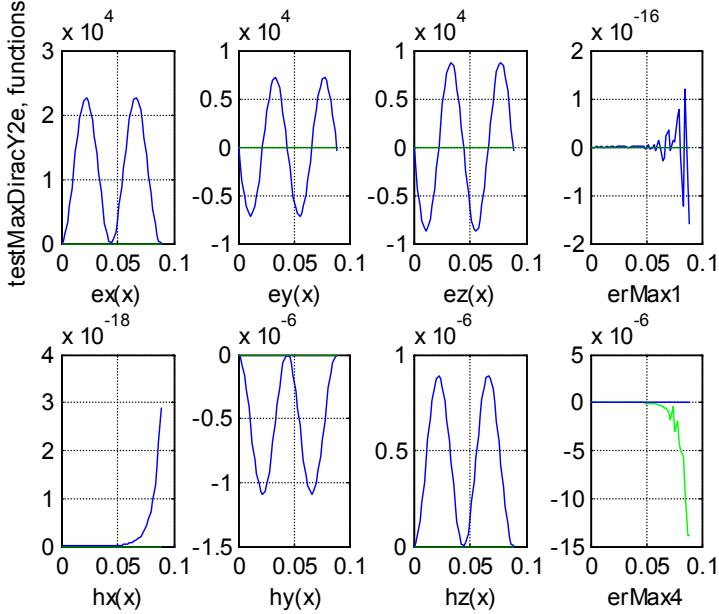

Fig. 9.3.3.2a. Electrical charges in vacuum.

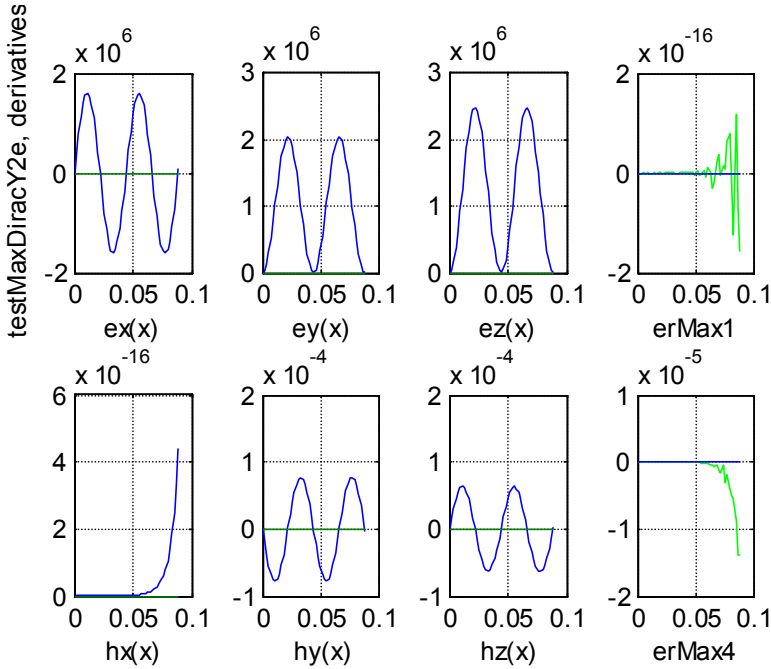

Fig. 9.3.3.2b. Electrical charges in vacuum.

### 9.3.3.2. Electrical charges in vacuum.

Let us now discuss the case when only electrical charges are present – see also function `testMaxDiracY2e`. The solution is as follows (12, 13). An example of equation (40) solution for  $\theta = 90$ ,  $\beta = 110$ ,  $\omega = 1000$ ,  $\sigma_o = 0$ ,  $\rho_o = 10^{-7}$  is shown on Fig. 9.3.3.2.

### 9.3.3.3. Harmonic static magnetic field

Let us consider a particular case when  $\gamma = \theta$ ,  $\nu = 0$ ,  $\rho_o = 0$ . The function (1.1B) of magnetic charge density distribution assumes the form

$$\sigma(x, y, z) = \sigma_o \text{Chp}(\gamma z) \text{Chd}(\gamma y) \lambda'(x), \quad (18)$$

and remain in accordance with (3.3, 3.4) and Table 1, and and there remain only magnetic charge density distribution functions of the form:

$$q = \left\{ \begin{array}{l} f_{hx}(x) = h_x(\lambda(x) - 1 + \cos(\chi x)) \\ f_{hy}(x) = h'_y \sin(\chi x) \\ f_{hz}(x) = h'_z \sin(\chi x) \end{array} \right\}, \quad (19)$$

$$\frac{dq}{dx} = \left\{ \begin{array}{l} \partial f_{hx}(x) / \partial x = h_x(\lambda'(x) - \chi \sin(\chi x)) \\ \partial f_{hy}(x) / \partial x = \chi h'_y(\lambda(x) - 1 + \cos(\chi x)) \\ \partial f_{hz}(x) / \partial x = \chi h'_z(\lambda(x) - 1 + \cos(\chi x)) \end{array} \right\}. \quad (20)$$

Hence for  $\nu = 0$  there exists only a static magnetic field (19, 20).

### 9.3.3.4. Harmonic static electric field

Let us consider another particular case when  $\beta = \theta$ ,  $\nu = 0$ ,  $\sigma_o = 0$ . The function (1.1a) of magnetic charge density distribution assumes the form

$$\rho(x, y, z, t) = \rho_o \text{Chp}(\beta z) \text{Shd}(\beta y) \lambda'(x). \quad (21)$$

and remain in accordance with (3.3, 3.4) and Table 1, and there remain only the electric field density distribution functions

$$q = \left\{ \begin{array}{l} f_{ex}(x) = e_x(\lambda(x) - 1 + \cos(\chi x)) \\ f_{ey}(x) = e'_y \sin(\chi x) \\ f_{ez}(x) = e'_z \sin(\chi x) \end{array} \right\}, \quad (22)$$

$$\frac{dq}{dx} = \left\{ \begin{array}{l} \partial f_{ex}(x) / \partial x = e_x(\lambda'(x) - \chi \sin(\chi x)) \\ \partial f_{ey}(x) / \partial x = \chi e'_y(\lambda(x) - 1 + \cos(\chi x)) \\ \partial f_{ez}(x) / \partial x = \chi e'_z(\lambda(x) - 1 + \cos(\chi x)) \end{array} \right\}. \quad (23)$$

Hence for  $\nu = 0$  there exists only a static electric field which satisfies the equations (22, 23).

## 9.4. Using the method for $\Xi(x) = \lambda(x)$ and $k_{sp} = k_{sd} = k_{cp} = k_{cd} = 1$ .

In this section the step-function  $\Xi(x) = \lambda(x)$  is being considered.

### 9.4.1. General solution

Similarly to the Section 9.3.1 and according to algorithm 6.7 and formulas (1.43, 1.48) we shall now discuss the iterative process, assuming that  $q_o(x) = 0$ .



$$\begin{aligned}
 u_1(x) &= & q_1(x) &= & u_2(x) &= & q_2(x) &= \\
 &= \lambda \begin{bmatrix} \rho_o/\varepsilon \\ 0 \\ 0 \\ \sigma_o/\mu \\ 0 \\ 0 \\ 0 \\ 0 \end{bmatrix}, & & = x \begin{bmatrix} \rho_o/\varepsilon \\ 0 \\ 0 \\ \sigma_o/\mu \\ 0 \\ 0 \\ 0 \\ 0 \end{bmatrix}, & & = x \begin{bmatrix} 0 \\ \theta\rho_o/\varepsilon \\ \beta\rho_o/\varepsilon \\ 0 \\ \theta\sigma_o/\mu \\ \beta\sigma_o/\mu \\ \omega\rho_o/\eta \\ -\omega\sigma_o/\zeta \end{bmatrix}, & & = \frac{x^2}{2} \begin{bmatrix} 0 \\ \theta\rho_o/\varepsilon \\ \beta\rho_o/\varepsilon \\ 0 \\ \theta\sigma_o/\mu \\ \beta\sigma_o/\mu \\ \omega\rho_o/\eta \\ -\omega\sigma_o/\zeta \end{bmatrix}.
 \end{aligned}$$

And so on. Since we have here the same matrix (3.1), on each iteration the difference of functions  $u(x)$ ,  $q(x)$ , obtained here an in the Section 9.3.1, will be only in the variable multiplier placed before the square brackets. More specifically, if the multipliers in Section 9.3.1 for the functions  $u(x)$ ,  $q(x)$  were accordingly

$$\lambda', \lambda, x, x^2/2!, \dots \text{ и } \lambda, x, x^2/2!, x^3/3!, \dots$$

here for the functions  $u(x)$ ,  $q(x)$  they are accordingly

$$\lambda, x, x^2/2!, x^3/3!, \dots \text{ и } x, x^2/2!, x^3/3!, x^4/4!, \dots$$

Hence, the functions  $u(x)$ ,  $q(x)$  in this case are negative integrals of the similar functions from Section 9.3.1. And in this case the solution will be a negative integral of the solution (9.3.3, 9.3.4), and has the following form:

$$q = \begin{bmatrix} f_{ex}(x) = -(e_x/\chi)\sin(\chi x) \\ f_{ey}(x) = (e'_y/\chi)\cos(\chi x) - e''_y(-x + (1/\chi)\sin(\chi x)) \\ f_{ez}(x) = (e'_z/\chi)\cos(\chi x) + e''_z(-x + (1/\chi)\sin(\chi x)) \\ f_{hx}(x) = -(h_x/\chi)\sin(\chi x) \\ f_{hy}(x) = (h'_y/\chi)\cos(\chi x) + h''_y(-x + (1/\chi)\sin(\chi x)) \\ f_{hz}(x) = (h'_z/\chi)\cos(\chi x) - h''_z(-x + (1/\chi)\sin(\chi x)) \\ f_\varphi(x) = (\varphi_x/\chi)\cos(\chi x) \\ f_\phi(x) = (\phi_x/\chi)\cos(\chi x) \end{bmatrix}, \tag{1}$$

$$\frac{dq}{dx} = \left[ \begin{array}{l} \partial f_{e_x}(x) / \partial x = e_x (\lambda(x) - \cos(\chi x)) \\ \partial f_{e_y}(x) / \partial x = -e'_y \sin(\chi x) - e''_y \cos(\chi x) \\ \partial f_{e_z}(x) / \partial x = -e'_z \sin(\chi x) + e''_z \cos(\chi x) \\ \partial f_{h_x}(x) / \partial x = h_x (\lambda(x) - \cos(\chi x)) \\ \partial f_{h_y}(x) / \partial x = -h'_y \sin(\chi x) + h''_y \cos(\chi x) \\ \partial f_{h_z}(x) / \partial x = -h'_z \sin(\chi x) - h''_z \cos(\chi x) \\ \partial f_{\phi}(x) / \partial x = -\phi_x \sin(\chi x) \\ \partial f_{\phi}(x) / \partial x = -\phi_x \sin(\chi x) \end{array} \right]. \quad (2)$$

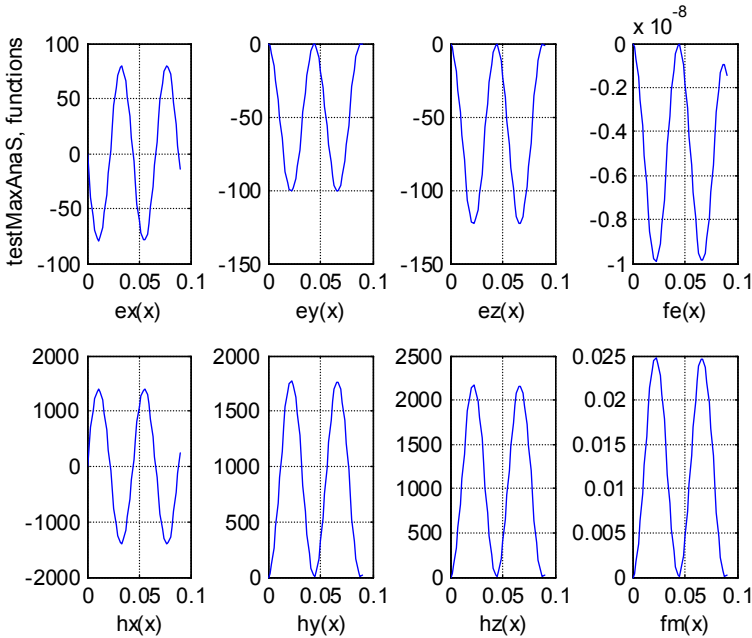

Fig. 9.4.1a. General solution for  $\Xi(x) = \lambda(x)$  and  $k_{sp} = k_{sd} = k_{cp} = k_{cd} = 1$ .

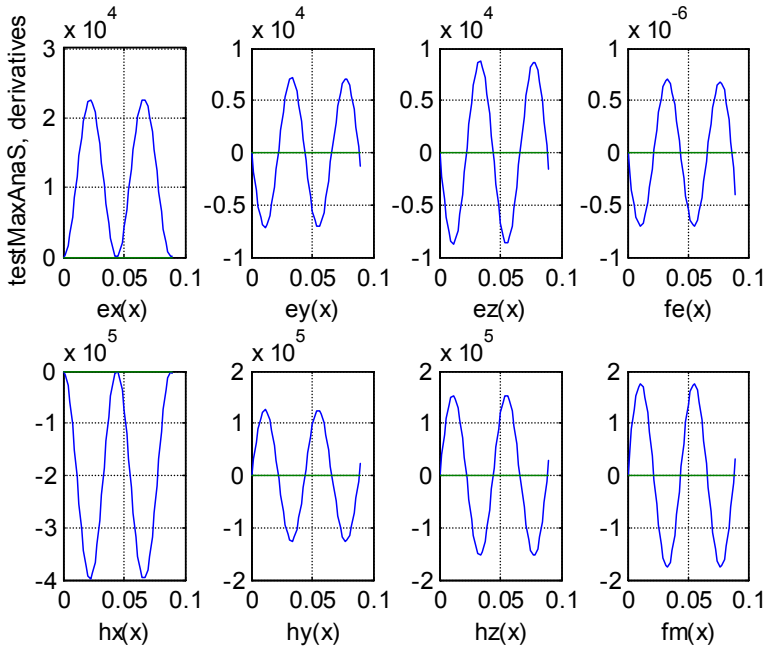

Fig. 9.4.1b

We shall find the solution of this problem by solving directly the equation (1.36). An example of solving equation (121) for  $\omega = 2500$ ,  $\gamma = 6000$ ,  $\beta = 200$ ,  $\rho_o = 5 \cdot 10^4$ ,  $\sigma_o = 2 \cdot 10^5$  is given on the Fig. 9.4.1 – see also function `testMaxAnaS`. The Figures show that the obtained solution complies with the analytical solution (1, 2). No components of the form  $(-x + (1/\chi)\sin(\chi x))$  due to the fact that for small  $x$ , this term is close to zero.

**9.4.2. Magnetic charges in vacuum**

In this case (1, 2), taking into account Table. 1 will be:

$$q = \left[ \begin{array}{l} f_{ex}(x) = 0 \\ f_{ey}(x) = -e''_y(-x + (1/\chi)\sin(\chi x)) \\ f_{ez}(x) = e''_z(-x + (1/\chi)\sin(\chi x)) \\ f_{hx}(x) = -(h_x/\chi)\sin(\chi x) \\ f_{hy}(x) = (h'_y/\chi)\cos(\chi x) \\ f_{hz}(x) = (h'_z/\chi)\cos(\chi x) \\ f_\phi(x) = 0 \\ f_\phi(x) = 0 \end{array} \right] \quad (3)$$

$$\frac{dq}{dx} = \left[ \begin{array}{l} \partial f_{ex}(x) / \partial x = 0 \\ \partial f_{ey}(x) / \partial x = -e''_y \cos(\chi x) \\ \partial f_{ez}(x) / \partial x = e''_z \cos(\chi x) \\ \partial f_{hx}(x) / \partial x = h_x(\lambda(x) - \cos(\chi x)) \\ \partial f_{hy}(x) / \partial x = -h'_y \sin(\chi x) \\ \partial f_{hz}(x) / \partial x = -h'_z \sin(\chi x) \\ \partial f_\phi(x) / \partial x = 0 \\ \partial f_\phi(x) / \partial x = 0 \end{array} \right] \quad (4)$$

We shall find the solution of this problem by solving directly the equation (1.36) – see also function `testMaxAnaS`. An example of solving equation (121) for  $\theta = 90$ ,  $\beta = 110$ ,  $\omega = 1000$ ,  $\sigma_o = -0.25$ ,  $\rho_o = 0$  is given on Fig. 9.4.2. The Figures show that the obtained solution complies with the analytical solution (3, 4). It is not visible members with small  $e''$  (see Table. 1), and component  $f_\phi(x)$  - systematic error, which has a value  $10^{-5}$ .

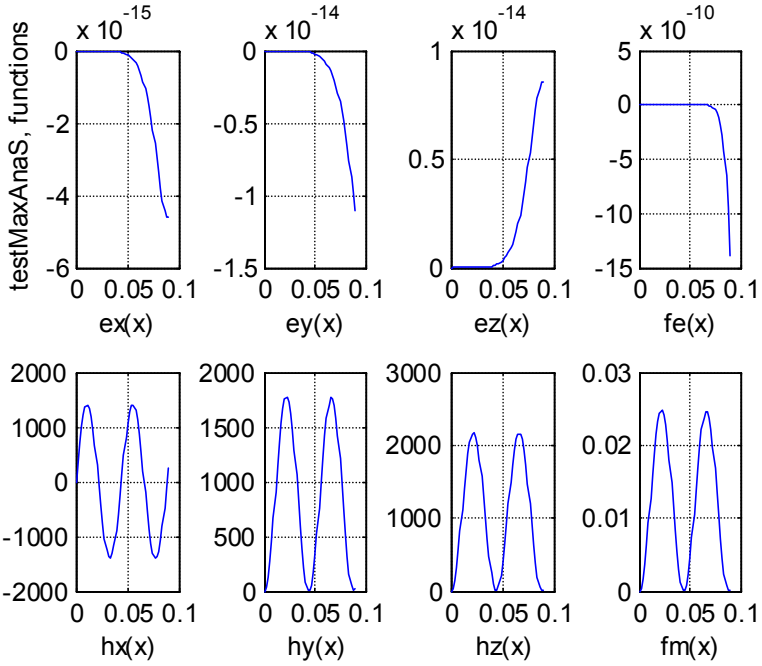

Fig. 9.4.2a. Magnetic charges in vacuum

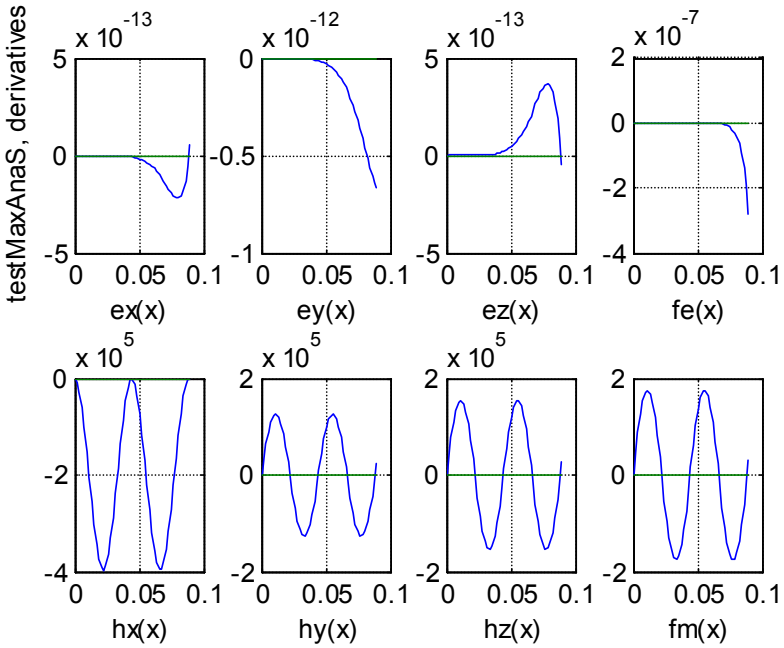

Fig. 9.4.2b.

9.4.3. Electrical charges in vacuum.

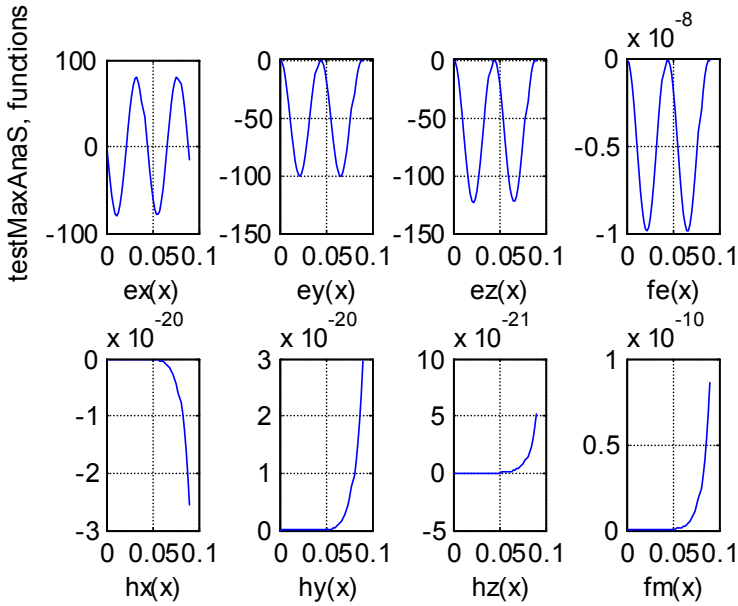

Fig. 9.4.3a. Electrical charges in vacuum

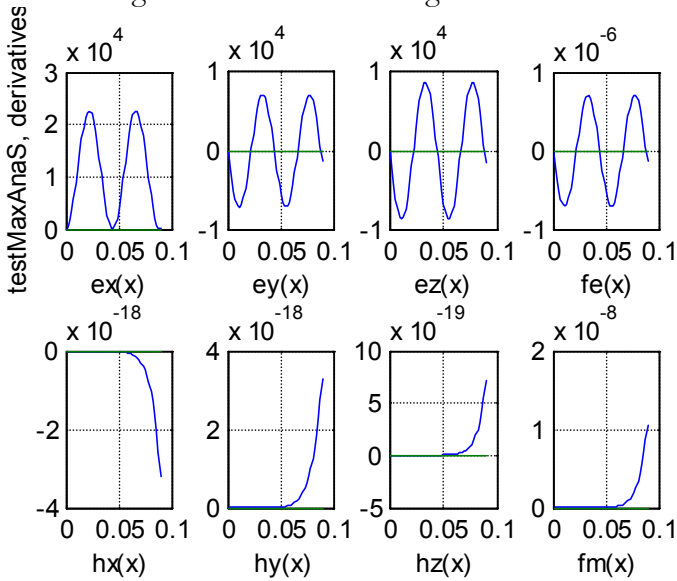

Fig. 9.4.3b.

In this case (1, 2), taking into account 16, assume the form :

$$q = \left[ \begin{array}{l} f_{ex}(x) = -(e_x/\chi)\sin(\chi x) \\ f_{ey}(x) = (e'_y/\chi)\cos(\chi x) \\ f_{ez}(x) = (e'_z/\chi)\cos(\chi x) \\ f_{hx}(x) = 0 \\ f_{hy}(x) = h''_y(-x + (1/\chi)\sin(\chi x)) \\ f_{hz}(x) = -h''_z(-x + (1/\chi)\sin(\chi x)) \\ f_\varphi(x) = 0 \\ f_\phi(x) = 0 \end{array} \right], \quad (5)$$

$$\frac{dq}{dx} = \left[ \begin{array}{l} \partial f_{ex}(x)/\partial x = e_x(\lambda(x) - \cos(\chi x)) \\ \partial f_{ey}(x)/\partial x = -e'_y \sin(\chi x) \\ \partial f_{ez}(x)/\partial x = -e'_z \sin(\chi x) \\ \partial f_{hx}(x)/\partial x = 0 \\ \partial f_{hy}(x)/\partial x = h''_y \cos(\chi x) \\ \partial f_{hz}(x)/\partial x = -h''_z \cos(\chi x) \\ \partial f_\varphi(x)/\partial x = 0 \\ \partial f_\phi(x)/\partial x = 0 \end{array} \right]. \quad (6)$$

We shall find the solution of this problem by solving directly the equation (1.36) – see also function `testMaxAna`. An example of solving equation (121) for  $\theta = 90$ ,  $\beta = 110$ ,  $\omega = 1000$ ,  $\sigma_o = 0$ ,  $\rho_o = 10^{-7}$  is given on Fig. 9.4.3. The Figures show that the obtained solution complies with the analytical solution (5, 6). There are no small members with small  $h''$  (see Table 1), and the component  $f_\phi(x)$  is the methodical error of the value  $10^{-8}$ .

#### 9.4a. Using the method for impulse function $\Xi(x)$ and $k_{sp} = k_{sd} = k_{cp} = k_{cd} = 1$ .

In this Section we shall consider impulse function

$$\Xi(x) = \lambda(x) - \lambda(x + \delta),$$

where  $\delta$  - the impulse width. First of all we must note that for a small enough  $\delta$

$$\cos(\chi x) - \cos(\chi(x + \delta)) \approx \delta\chi \sin(\chi x), \quad (1)$$

$$\sin(\chi x) - \sin(\chi(x + \delta)) \approx -\delta\chi \cos(\chi x). \quad (2)$$

Let us denote as  $q_{\lambda'}(x)$  f (3.3),  $q_{\lambda}(x)$  f (4.1),  $q_{\delta}(x)$  the function found for  $\Xi(x)$  being: Dirac function, step function and impulse function, accordingly.

The solution in this case may be found as the difference :

$$q_{\delta}(x) = q_{\lambda}(x) - q_{\lambda}(x + \delta), \quad (3)$$

where  $q_{\lambda}(x)$  are determined by (4.1). Getting this difference from (1, 2), we find

$$q_{\delta} = \delta \cdot \left[ \begin{array}{l} f_{ex}(x) = (e_x/\chi)\cos(\chi x) \\ f_{ey}(x) = (e'_y/\chi)\sin(\chi x) + e''_y((1/\chi) + \cos(\chi x)) \\ f_{ez}(x) = (e'_z/\chi)\sin(\chi x) - e''_z((1/\chi) + \cos(\chi x)) \\ f_{hx}(x) = (h_x/\chi)\cos(\chi x) \\ f_{hy}(x) = (h'_y/\chi)\sin(\chi x) - h''_y((1/\chi) + \cos(\chi x)) \\ f_{hz}(x) = (h'_z/\chi)\sin(\chi x) + h''_z((1/\chi) + \cos(\chi x)) \\ f_{\varphi}(x) = (\varphi_x/\chi)\sin(\chi x) \\ f_{\phi}(x) = (\phi_x/\chi)\sin(\chi x) \end{array} \right], \quad (4)$$

Disregarding the values  $e''$ ,  $h''$  as small compared with  $e'$ ,  $h'$  (See Table. 1), and discarding the items with  $e''$ ,  $h''$  in formulas (4.1) and (4), we notice that

$$q_{\delta}(x) \approx \delta \cdot q_{\lambda'}(x). \quad (5)$$

Let us assume that the charges are distributed in a plate  $\delta$  -thick. Let us call plate density of a charge – a charge located in a unit of area of the plate. Let us denote as  $\overline{\rho}$ ,  $\overline{\sigma}$  the plate density of an electric and a magnetic charges accordingly, and as  $\overline{\rho}_0$ ,  $\overline{\sigma}_0$  - their amplitudes. For a uniform distribution of charges through the plate's thickness

$$\overline{\rho}_0 = \overline{\rho} \cdot \delta, \quad \overline{\sigma}_0 = \overline{\sigma} \cdot \delta. \quad (6)$$

The functions  $q_{\lambda'}(x)$  f (3.3),  $q_{\lambda}(x)$  f (4.1),  $q_{\delta}(x)$  f (4) are determined according to coefficients shown in the Table 1. Let us consider also the functions  $\overline{q_{\lambda'}}$ ,  $\overline{q_{\lambda}}$ ,  $\overline{q_{\delta}}$ , which differ from the



previous ones by the fact, that their coefficients depend not on volume density of charges  $\rho_o, \sigma_o$ , but on plate density of the charges  $\overline{\rho_o}, \overline{\sigma_o}$ . Because of (6) we have:

$$\overline{q_{\lambda'}}/\delta = q_{\lambda'}, \quad \overline{q_{\lambda}}/\delta = q_{\lambda}, \quad \overline{q_{\delta}}/\delta = q_{\delta}. \quad (7)$$

Combining (5, 7) we get:

$$\overline{q_{\delta}}(x) \approx \overline{q_{\lambda'}}(x). \quad (8)$$

It means that

for given  $\overline{\rho_o}, \overline{\sigma_o}$  the functions  $\overline{q_{\delta}}$  **do not depend** on the plate's thickness.

In particular, for  $\delta \rightarrow 0$  we have  $[\rho_o, \sigma_o] \rightarrow [\overline{\rho_o}, \overline{\sigma_o}]/\delta$  or

$$[\rho_o, \sigma_o] \xrightarrow{\delta \rightarrow 0} \lambda' \cdot [\overline{\rho_o}, \overline{\sigma_o}]. \quad (9)$$

The last formula reveals the physical sense of using Dirac functions as the charges distribution functions.

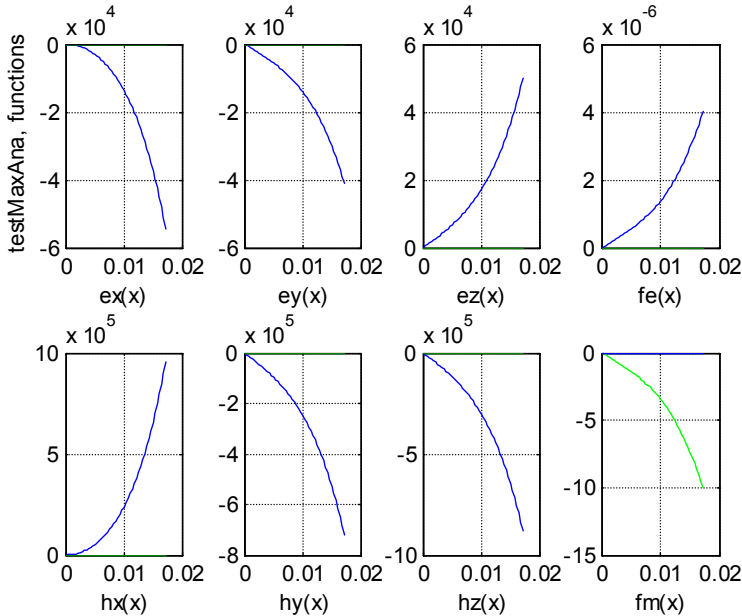

Fig. 9.5.1a. General solution for  $\Xi(x) = \lambda'(x)$ ,

$$k_{sp} = k_{sd} = 1, \quad k_{cp} = k_{cd} = -1,$$

$$\text{modeFig}=1, \text{mode}=2, \text{modeZ}=2.$$

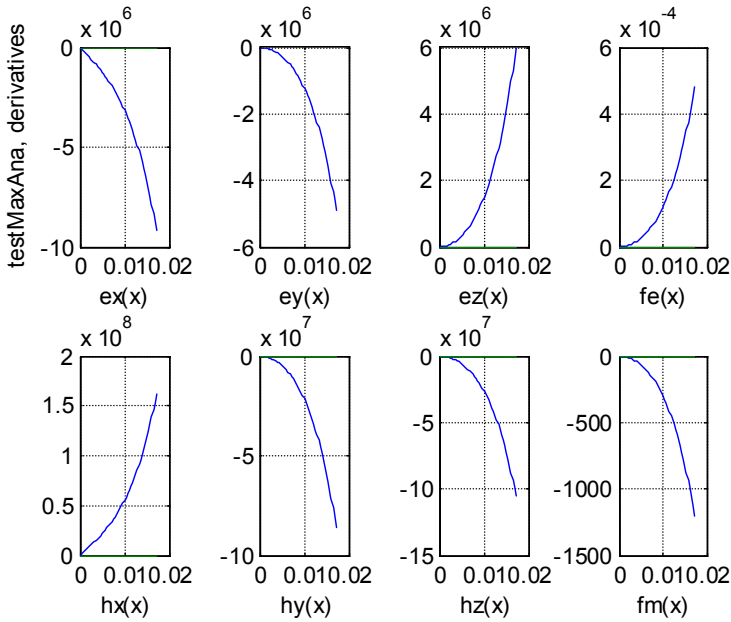

Fig. 9.5.1b, modeFig=2, mode=2, modeZ=2.

**9.5. Using the method for  $\Xi(x)=\lambda'(x)$  and  $k_{sp} = k_{sd} = 1, k_{cp} = k_{cd} = -1$ .**

We shall find the solution of this problem by solving directly the equation (1.36) - see also function testMaxAna. An example of equation (1.36) solution for  $\theta = 90, \beta = 110, \omega = 1000, \sigma_o = -0.25, \rho_o = 10^{-7}$  is given on Fig. 9.5.1. In this case the functions (1.15) are monotonous and are expressed by hyperbolic sines and cosines.

**9.6. Using the method for  $\Xi(x)=\lambda(x)$  and  $k_{sp} = k_{sd} = 1, k_{cp} = k_{cd} = -1$ .**

We shall find the solution of this problem by solving directly the equation (1.36) - see also function testMaxAnaS. An example of equation (1.36) solution for  $\omega = 2500, \gamma = 6000, \beta = 200, \rho_o = 5 \cdot 10^4, \sigma_o = 2 \cdot 10^5$  is given on Fig. 9.6.1. In this case the functions (1.15) are monotonous and are expressed by hyperbolic sines and cosines.

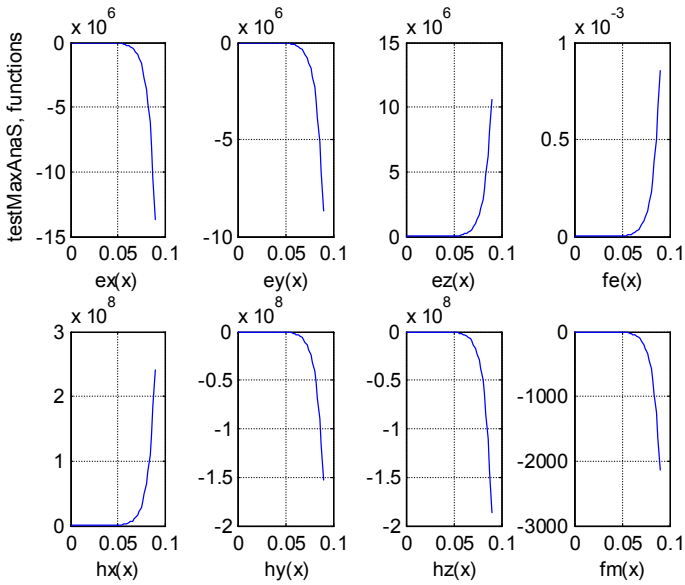

Fig. 9.6.1a. General solution for  $\Xi(x) = \lambda(x)$ ,  
 $k_{sp} = k_{sd} = 1$ ,  $k_{cp} = k_{cd} = -1$ , modeFig=1, mode=2, modeZ=2.

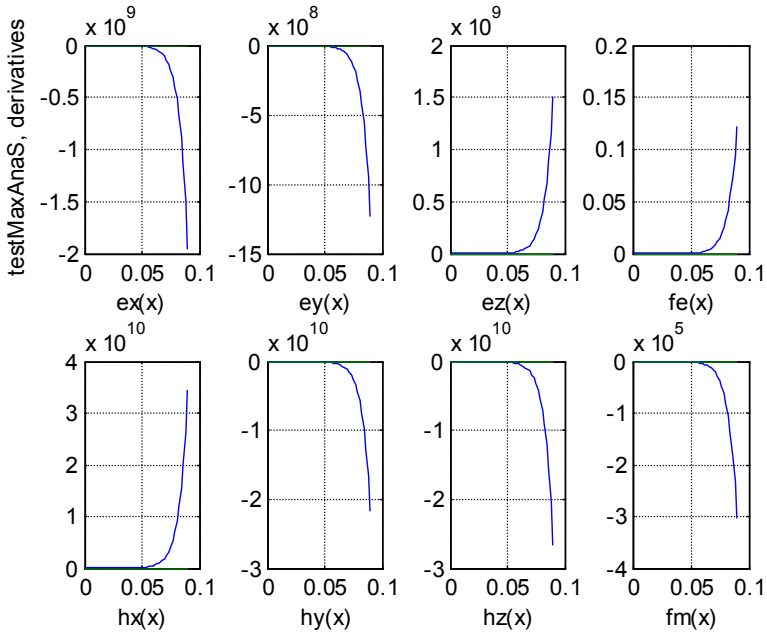

Fig. 9.6.1b, modeFig=1, mode=2, modeZ=2.

## 10. A summary of models from Sections 9.6, 9.7, 9.8.

Here, for convenience sake we shall summarize the main characteristics of the models. Table 1 shows the magnetic and electric charges density distributions formulas, and Table 2 contains the formulas for intensities and scalar potentials. Further we shall be using the following notations:

$$\Psi_{sc} = \text{Sin}(\omega t) \text{Cos}(\beta z), \tag{1}$$

$$\Psi_{cs} = \text{Cos}(\omega t) \text{Sin}(\beta z), \tag{2}$$

$$\Psi_{ss} = \text{Sin}(\omega t) \text{Sin}(\beta z), \tag{3}$$

$$\Psi_{cc} = \text{Cos}(\omega t) \text{Cos}(\beta z), \tag{4}$$

$$\Omega = \text{Cos}(\omega t + \beta z), \tag{5}$$

$$\Psi = \text{Sin}(\omega t + \beta z), \tag{6}$$

$$\Omega = \Psi_{cc} - \Psi_{ss}, \tag{7}$$

$$\Psi = \Psi_{sc} + \Psi_{cs}, \tag{8}$$

$$\Omega_2 = \text{Cos}(\omega t + \alpha y + \beta z), \tag{9}$$

$$\Psi_2 = \text{Sin}(\omega t + \alpha y + \beta z). \tag{10}$$

Table 1.

| $\rho =$   | $\sigma =$   |
|--|--|
| 9.6.5. Exponentially Distributed Charges Modeling  |  |
| $-\rho_o \Psi_{cc} e^{\lambda x + \gamma y}$   | $-\sigma_o \Psi_{ss} e^{\lambda x + \gamma y}$           |
| 9.6.6. Periodically Distributed Charges Modeling   |  |
| $-\rho_o \Psi_{cc} \text{Sin}(\lambda x) e^{\gamma y}$                                   | $-\sigma_o \Psi_{ss} \text{Sin}(\lambda x) e^{\gamma y}$ |
| 9.6.7. Modeling with Charges Distributed According to Dirac Function                     |  |
| - independent electric and magnetic fields   |  |
| $-\rho_o \Psi_{cc} \lambda'(x) e^{\gamma y}$   | $-\sigma_o \Psi_{ss} \lambda'(x) e^{\gamma y}$           |
| 9.6.7a. Magnetic wave in simulation with charges distributed according to Dirac function |  |

|   |  |
|---|--|
|   | $-\sigma_o \Psi_{ss} \lambda'(x) e^{\mathcal{N}}$      |
| 9.6.7B. Electric wave in simulation with charges distributed according to Dirac function  |  |
| $-\rho_o \Psi_{cc} \lambda'(x) e^{\mathcal{N}}$   |  |
| 9.6.8. Modeling of wave with Charges Distributed According to Step Function   |  |
| $-\rho_o \Psi_{cc} \lambda(x) e^{\mathcal{N}}$  | $-\sigma_o \Psi_{ss} \lambda(x) e^{\mathcal{N}}$       |
| 9.6.9. Modeling of wave with Charges Distributed Non-uniformly<br>- $\Pi(x)$ - multi-step trapezium (in particular, square pulse)       |  |
| $-\rho_o \Psi_{cc} \Pi(x) e^{\mathcal{N}}$  | $-\sigma_o \Psi_{ss} \Pi(x) e^{\mathcal{N}}$           |
| 9.7.1. Electromagnetic oscillations with exponentially distributed charges. Case 1.   |  |
| $\rho_o \Psi_{cc} e^{\lambda x + \mathcal{N}}$  | $-\sigma_o \Psi_{ss} e^{\lambda x + \mathcal{N}}$      |
| 9.7.2. Electromagnetic oscillations with exponentially distributed charges. Case 2.   |  |
| $-\rho_o \Psi_{ss} e^{\lambda x + \mathcal{N}}$   | $\sigma_o \Psi_{cc} e^{\lambda x + \mathcal{N}}$       |
| 9.7.3. Electromagnetic oscillations with linear movement of exponentially distributed charges<br>- longitudinal electromagnetic wave    |  |
| $\rho_o \Omega e^{\lambda x + \mathcal{N}}$ ,   | $\sigma = \sigma_o \Omega e^{\lambda x + \mathcal{N}}$ |
| 9.7.3a. Electromagnetic oscillations at compound motion of the exponentially distributed charges<br>- longitudinal electromagnetic wave |  |
| $\rho_o \Omega_2 e^{\lambda x}$ ,   | $\rho_o \Psi_2 e^{\lambda x}$ ,                        |
| 9.7.4. Magnetic oscillations with charges distributed according to Dirac function. Case 1.  |  |
|   | $-\sigma_o \Psi_{ss} \lambda'(x) e^{\mathcal{N}}$      |
| 9.7.5. Magnetic oscillations with charges distributed according to Dirac function. Case 2.  |  |
|   | $\sigma_o \Psi_{cc} \lambda'(x) e^{\mathcal{N}}$       |
| 9.7.6. Magnetic oscillations with linear movement of charges,   |  |

|  |   |
|--|---|
| distributed according to Dirac function<br>- possibly magnetostatic field<br>- longitudinal magnetic wave $H_z$<br>- energy-dependent magnetic wave standing magnetic wave $H_x$   |   |
|  | $\sigma_o \Omega \lambda'(x) e^{\gamma y}$  |
| 9.8.4. Modeling of wave with electric and magnetic charges exponentially distributed along $y, z$ axes and with Dirac distribution along $x$ axis.<br>- independent electric and magnetic fields                                       |   |
| $\rho_o \text{Cos}(\omega t) e^{\gamma y + \beta z} \lambda'(x)$   | $\sigma_o \text{Sin}(\omega t) e^{\gamma y + \beta z} \lambda'(x)$                                  |
| 9.8.4a. Modeling of wave with magnetic and electric charges distributed periodically along the $y, z$ axes and with Dirac distribution along $x$ axis<br>- independent electric and magnetic fields                                    |   |
| $\rho = \rho_o \text{Cos}(\omega t) \text{Cos}(\gamma y) \cdot \text{Cos}(\beta z) \lambda'(x)$<br>or<br>$\rho = \rho_o \text{Sin}(\omega t) \text{Cos}(\gamma y) \cdot \text{Cos}(\beta z) \lambda'(x)$                               | $\sigma = \sigma_o \text{Sin}(\omega t) \text{Cos}(\gamma y) \cdot \text{Cos}(\beta z) \lambda'(x)$ |
| 9.8.5. Modeling of wave with magnetic charges distributed exponentially along the axes $y, z$ and with Dirac function distribution along $x$ axis<br>- energy-dependent standing magnetic wave $H_x$<br>- possibly magnetostatic field |   |
|  | $\sigma_o \text{Sin}(\omega t) e^{\gamma y + \beta z} \lambda'(x)$                                  |
| 9.8.5a. Modeling of wave with magnetic charges periodically distributed along the axes $y, z$ and with Dirac distribution along the $x$ axis<br>- energy-dependent standing electric wave $E_x$<br>- possibly magnetostatic field      |   |
|  | $\sigma = \sigma_o \text{Sin}(\omega t) \text{Cos}(\gamma y) \cdot \text{Cos}(\beta z) \lambda'(x)$ |
| 9.8.6. Modeling of wave with electric charges exponentially  |   |

|   |  |
|---|--|
| distributed along the axes $y, z$ and with Dirac distribution along the $x$ axis<br>- energy-dependent standing electric wave $E_x$<br>- possibly electrostatic field   |  |
| $\rho_o \text{Cos}(\omega t) e^{\gamma y + \beta z} \lambda'(x)$  |  |
| 9.8.6a. Modeling of wave with electric charges distributed periodically along the axes $y, z$ and with Dirac distribution along the $x$ axis<br>- energy-dependent standing electric wave $E_x$<br>- possibly electrostatic field |  |
| $\rho = \rho_o \text{Cos}(\omega t) \text{Cos}(\gamma y) \cdot \text{Cos}(\beta z) \lambda'(x)$   |  |

Table 2.

|  |             |             |                 |              |
|--|-------------|-------------|-----------------|--------------|
|  | $q_1 = E_x$ | $q_2 = E_y$ | $q_3 = E_z$     | $q_4 = H_x$  |
|  | $q_5 = H_y$ | $q_6 = H_z$ | $q_7 = \varphi$ | $q_8 = \phi$ |

Sections 9.6.5, 9.6.6

|             |                         |                         |                         |                         |
|-------------|-------------------------|-------------------------|-------------------------|-------------------------|
| $q_x$ 9.6.5 | $e^{\chi x}$            |                         |                         |                         |
| $q_x$ 9.6.6 | $\text{Sin}(\chi x)$    |                         |                         |                         |
| $q_y$       | $e^{\gamma y}$          |                         |                         |                         |
| $q_z$       | $\text{Cos}(\beta z)$   | $\text{Cos}(\beta z)$   | $-\text{Sin}(\beta z)$  | $\text{Sin}(\beta z)$   |
|             | $\text{Sin}(\beta z)$   | $-\text{Cos}(\beta z)$  | $-\text{Cos}(\beta z)$  | $-\text{Sin}(\beta z)$  |
| $q_t$       | $-\text{Cos}(\omega t)$ | $-\text{Cos}(\omega t)$ | $-\text{Cos}(\omega t)$ | $-\text{Sin}(\omega t)$ |
|             | $-\text{Sin}(\omega t)$ | $\text{Sin}(\omega t)$  | $\text{Sin}(\omega t)$  | $-\text{Cos}(\omega t)$ |

Sections 9.6.7, 9.6.7a, 9.6.7b.

|       |                         |                         |                         |                         |
|-------|-------------------------|-------------------------|-------------------------|-------------------------|
| $q_x$ | $-\text{Cos}(\chi x)$   | $-\text{Sin}(\chi x)$   | $-\text{Sin}(\chi x)$   | $-\text{Cos}(\chi x)$   |
|       | $-\text{Sin}(\chi x)$   | $-\text{Sin}(\chi x)$   | $-\text{Sin}(\chi x)$   | $-\text{Sin}(\chi x)$   |
| $q_y$ | $e^{\gamma y}$          |                         |                         |                         |
| $q_z$ | $\text{Cos}(\beta z)$   | $\text{Cos}(\beta z)$   | $-\text{Sin}(\beta z)$  | $\text{Sin}(\beta z)$   |
|       | $\text{Sin}(\beta z)$   | $-\text{Cos}(\beta z)$  | $-\text{Cos}(\beta z)$  | $-\text{Sin}(\beta z)$  |
| $q_t$ | $-\text{Cos}(\omega t)$ | $-\text{Cos}(\omega t)$ | $-\text{Cos}(\omega t)$ | $-\text{Sin}(\omega t)$ |
|       | $-\text{Sin}(\omega t)$ | $\text{Sin}(\omega t)$  | $\text{Sin}(\omega t)$  | $-\text{Cos}(\omega t)$ |

Sections 9.7.1, 9.7.2, 9.7.3.

|                     |                |             |             |              |
|---------------------|----------------|-------------|-------------|--------------|
| $q_x$               | $e^{\chi x}$   |             |             |              |
| $q_y$               | $e^{\gamma y}$ |             |             |              |
| $q_z, q_t$<br>9.7.1 | $\Psi_{cc}$    | $\Psi_{cc}$ | $\Psi_{cs}$ | $-\Psi_{ss}$ |
|                     | $-\Psi_{ss}$   | $\Psi_{sc}$ | $\Psi_{sc}$ | $\Psi_{cs}$  |
| $q_z, q_t$<br>9.7.2 | $\Psi_{ss}$    | $\Psi_{ss}$ | $\Psi_{sc}$ | $\Psi_{cc}$  |
|                     | $\Psi_{cc}$    | $\Psi_{cs}$ | $\Psi_{cs}$ | $\Psi_{sc}$  |
| $q_z, q_t$<br>9.7.3 | $\Omega$       | $\Omega$    | $\Psi$      | $\Omega$     |
|                     | $\Omega$       | $\Psi$      | $\Psi$      | $\Psi$       |

Sections 9.7.3a.

|                 |              |            |          |            |
|-----------------|--------------|------------|----------|------------|
| $q_x$           | $e^{\chi x}$ |            |          |            |
| $q_z, q_z, q_t$ | $\Omega_2$   | $\Psi_2$   | $\Psi_2$ | $\Psi_2$   |
|                 | $\Omega_2$   | $\Omega_2$ | $\Psi_2$ | $\Omega_2$ |

Sections 9.7.4, 9.7.5, 9.7.6.

|                     |                       |                       |                       |                       |
|---------------------|-----------------------|-----------------------|-----------------------|-----------------------|
|                     | $q_4 = H_x$           | $q_5 = H_y$           | $q_6 = H_z$           | $q_8 = \phi$          |
| $q_x$               | $-\text{Cos}(\chi x)$ | $-\text{Sin}(\chi x)$ | $-\text{Sin}(\chi x)$ | $-\text{Sin}(\chi x)$ |
| $q_y$               | $e^{\gamma y}$        |                       |                       |                       |
| $q_z, q_t$<br>9.7.4 | $-\Psi_{ss}$          | $-\Psi_{ss}$          | $\Psi_{sc}$           | $\Psi_{cs}$           |
| $q_z, q_t$<br>9.7.5 | $\Psi_{cc}$           | $\Psi_{cc}$           | $\Psi_{cs}$           | $\Psi_{sc}$           |
| $q_z, q_t$<br>9.7.6 | $\Omega$              | $\Omega$              | $\Psi$                | $\Psi$                |

Sections 9.8.4, 9.8.5, 9.8.6

|       |                        |                        |                         |                         |
|-------|------------------------|------------------------|-------------------------|-------------------------|
| $q_x$ | $-\text{Cos}(\chi x)$  | $-\text{Sin}(\chi x)$  | $-\text{Sin}(\chi x)$   | $-\text{Cos}(\chi x)$   |
|       | $-\text{Sin}(\chi x)$  | $-\text{Sin}(\chi x)$  | $-\text{Sin}(\chi x)$   | $-\text{Sin}(\chi x)$   |
| $q_y$ | $\exp(\gamma y)$       |                        |                         |                         |
| $q_z$ | $\exp(\beta z)$        |                        |                         |                         |
| $q_t$ | $\text{Cos}(\omega t)$ | $\text{Cos}(\omega t)$ | $\text{Cos}(\omega t)$  | $\text{Sin}(\omega t)$  |
|       | $\text{Sin}(\omega t)$ | $\text{Sin}(\omega t)$ | $-\text{Sin}(\omega t)$ | $-\text{Cos}(\omega t)$ |



## Sections 9.8.4a, 9.8.5a, 9.8.6a

|       |                 |                 |                 |                 |
|-------|-----------------|-----------------|-----------------|-----------------|
| $q_x$ | $-Cos(\chi x)$  | $-Sin(\chi x)$  | $-Sin(\chi x)$  | $-Cos(\chi x)$  |
|       | $-Sin(\chi x)$  | $-Sin(\chi x)$  | $-Sin(\chi x)$  | $-Sin(\chi x)$  |
| $q_y$ | $Cos(\gamma y)$ | $Sin(\gamma y)$ | $Cos(\gamma y)$ | $Cos(\gamma y)$ |
|       | $Sin(\gamma y)$ | $Cos(\gamma y)$ | $Cos(\gamma y)$ | $Cos(\gamma y)$ |
| $q_z$ | $Cos(\beta z)$  | $Cos(\beta z)$  | $Sin(\beta z)$  | $Cos(\beta z)$  |
|       | $Cos(\beta z)$  | $Sin(\beta z)$  | $Cos(\beta z)$  | $Cos(\beta z)$  |
| $q_t$ | $Sin(\omega t)$ | $Sin(\omega t)$ | $Sin(\omega t)$ | $Cos(\omega t)$ |
|       | $Cos(\omega t)$ | $Cos(\omega t)$ | $Cos(\omega t)$ | $Sin(\omega t)$ |

## Sections 9.8.4a

|       |                 |                 |                 |                 |
|-------|-----------------|-----------------|-----------------|-----------------|
| $q_x$ | $-Cos(\chi x)$  | $-Sin(\chi x)$  | $-Sin(\chi x)$  | $-Cos(\chi x)$  |
|       | $-Sin(\chi x)$  | $-Sin(\chi x)$  | $-Sin(\chi x)$  | $-Sin(\chi x)$  |
| $q_y$ | $Cos(\gamma y)$ | $Sin(\gamma y)$ | $Cos(\gamma y)$ | $Cos(\gamma y)$ |
|       | $Sin(\gamma y)$ | $Cos(\gamma y)$ | $Cos(\gamma y)$ | $Cos(\gamma y)$ |
| $q_z$ | $Cos(\beta z)$  | $Cos(\beta z)$  | $Sin(\beta z)$  | $Cos(\beta z)$  |
|       | $Cos(\beta z)$  | $Sin(\beta z)$  | $Cos(\beta z)$  | $Cos(\beta z)$  |
| $q_t$ | $Cos(\omega t)$ | $Cos(\omega t)$ | $Cos(\omega t)$ | $Cos(\omega t)$ |
|       | $Cos(\omega t)$ | $Cos(\omega t)$ | $Sin(\omega t)$ | $Sin(\omega t)$ |

## 9.11. The Maxwell Equations in Cylindrical Coordinates

### 1. The first variant

Above we had considered the solution of Maxwell equations in Cartesian coordinates (9.5.1) for certain functions of density distribution for electric and magnetic charges. Here we shall consider the solution of the same problem in cylindrical coordinates  $r, y, \varphi$ . And here the Maxwell equations instead of (9.5.1) take the following form (see for instance [51]):

|    |   |     |
|----|---|-----|
| 1. | $\frac{1}{r} \cdot \frac{\partial(rH_\varphi)}{\partial r} - \frac{1}{r} \cdot \frac{\partial(H_y)}{\partial \varphi} - \varepsilon \frac{\partial E_r}{\partial t} - g \frac{d(\varphi')}{dx} = 0$ | (1) |
| 2. | $\frac{1}{r} \frac{\partial(H_r)}{\partial \varphi} - \frac{1}{r} \frac{\partial(rH_\varphi)}{\partial r} - \varepsilon \frac{\partial E_y}{\partial t} + g \frac{d(\varphi')}{dy} = 0$             |     |
| 3. | $\frac{1}{r} \frac{\partial(rH_y)}{\partial r} - \frac{\partial H_r}{\partial y} - \varepsilon \frac{\partial E_\varphi}{\partial t} + \frac{g}{r} \frac{d\varphi'}{d\varphi} = 0$                  |     |
| 4. | $\frac{\partial(E_\varphi)}{\partial y} - \frac{1}{r} \frac{\partial(E_y)}{\partial \varphi} + \mu \frac{\partial H_r}{\partial t} - \zeta \frac{d(r\phi)}{r d\varphi} = 0$                         |     |
| 5. | $\frac{1}{r} \frac{\partial(E_r)}{\partial \varphi} - \frac{1}{r} \frac{\partial(rE_\varphi)}{\partial r} + \mu \frac{\partial H_y}{\partial t} - \zeta \frac{d(\phi)}{dy} = 0$                     |     |
| 6. | $\frac{1}{r} \frac{\partial(rE_y)}{\partial r} - \frac{\partial E_r}{\partial y} + \mu \frac{\partial H_\varphi}{\partial t} - \zeta \frac{d\phi}{r d\varphi} = 0$                                  |     |
| 7. | $\frac{1}{r} \frac{\partial(rE_r)}{\partial r} + \frac{\partial E_y}{\partial y} + \frac{1}{r} \frac{\partial E_\varphi}{\partial \varphi} - \frac{\rho}{\varepsilon} = 0$                          |     |
| 8. | $\frac{1}{r} \frac{\partial(rH_r)}{\partial r} + \frac{\partial H_y}{\partial y} + \frac{1}{r} \frac{\partial H_\varphi}{\partial \varphi} - \frac{\sigma}{\mu} = 0$                                |     |

Here the electric potential (contrary to the previous) is denoted as  $\varphi'$ . Formally the transformation (9.5.1) in (1) may be performed according to the rule:

- the coordinates are re-denoted as:

- $x \Rightarrow r, y \Rightarrow y, z \Rightarrow r \cdot \varphi,$
- the derivatives are re-denoted as:
- $\frac{\partial H}{\partial x} \Rightarrow \frac{1}{r} \cdot \frac{\partial(rH)}{\partial r}, \frac{\partial H}{\partial y} \Rightarrow \frac{\partial H}{\partial y}, \frac{\partial H}{\partial z} \Rightarrow \frac{1}{r} \cdot \frac{\partial H}{\partial \varphi}.$

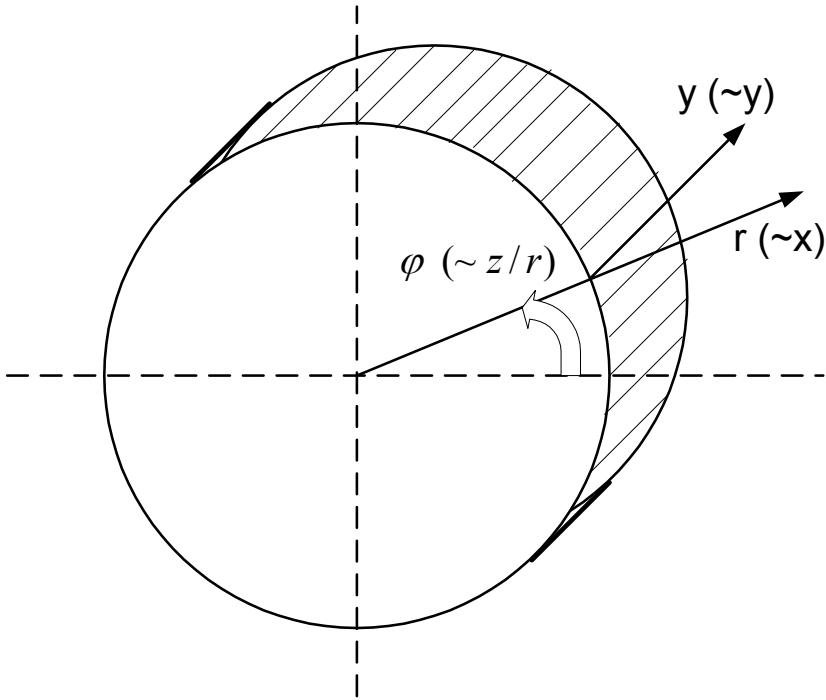

Fig. 1.

This transformation is explained on the Figure 1, where the axis  $Oy$  is a generatrix of the cylinder, the axis  $Ox \Rightarrow Or$  - is directed along the cylinder radius, the axis  $Oz \Rightarrow r \cdot \varphi$  is an arc of the cylinder.

We shall assume that the charges are distributed along the circle of radius  $R$ , and their distribution density functions may be presented as

$$\rho(r, \varphi, y, t) = \rho_0 \text{Ch}(\beta R \varphi + vt) \text{Ch}(\theta y) \lambda'(R), \quad (2)$$

$$\sigma(r, \varphi, y, t) = \sigma_0 \text{Ch}(\beta R \varphi + vt) \text{Ch}(\theta y) \lambda'(R). \quad (3)$$

We shall search for the solution of equations (1-3) in the form

$$E_r(r, \varphi, z, t) = \text{Ch}(\beta R \varphi + vt) \text{Ch}(\theta y) f_{er}(r), \quad (4)$$

$$E_\varphi(r, \varphi, z, t) = \text{Ch}(\beta R \varphi + vt) \text{Ch}(\theta y) f_{e\varphi}(r), \quad (5)$$

$$E_z(r, \varphi, z, t) = \text{Sh}(\beta R \varphi + vt) \text{Ch}(\theta y) f_{ez}(r), \quad (6)$$

$$H_r(r, \varphi, z, t) = \text{Ch}(\beta R \varphi + vt) \text{Ch}(\theta y) f_{hr}(r), \quad (7)$$

$$H_\varphi(r, \varphi, z, t) = \text{Ch}(\beta R \varphi + vt) \text{Ch}(\theta y) f_{h\varphi}(r), \quad (8)$$

$$H_z(r, \varphi, z, t) = \text{Sh}(\beta R \varphi + vt) \text{Ch}(\theta y) f_{hz}(r), \quad (9)$$

$$\varphi'(r, \varphi, z, t) = \text{Sh}(\beta R \varphi + vt) \text{Ch}(\theta y) f_\varphi(r), \quad (10)$$

$$\phi(r, \varphi, z, t) = \text{Sh}(\beta R \varphi + vt) \text{Ch}(\theta y) f_\phi(r), \quad (11)$$

where the functions

$$g(x) = \left\{ \begin{array}{l} f_{er}(r), f_{ey}(r), f_{e\varphi}(r), f_{hr}(r) \\ f_{h\varphi}(r), f_{h\phi}(r), f_\varphi(r), f_\phi(r) \end{array} \right\} \quad (12)$$

образуются из функций (1.1.12) по следующему правилу: тригонометрические функции вида  $\sin(\chi x)$ ,  $\cos(\chi x)$  заменяются

на функции вида  $\frac{\sin(\chi(r-R))}{r}$ ,  $\frac{\cos(\chi(r-R))}{r}$  соответственно.

are formed from the functions (1.1.12) by the following rule: trigonometrical functions  $\sin(\chi x)$ ,  $\cos(\chi x)$  are changed to the functions  $\frac{\sin(\chi(r-R))}{r}$ ,  $\frac{\cos(\chi(r-R))}{r}$  accordingly.

Let us substitute the functions (4-12) into equations (1), differentiate and reduce the common factors. Then we shall get an equations system with respect to the coefficients of functions (12), divided by  $r$ . From here it follows that the solution of this problem in cylindrical coordinates differs from the solution in Cartesian coordinates by a factor

$$\xi = \frac{R}{r}, \quad r \geq R.$$

This means that in Cartesian coordinates there exist undamped oscillations along the coordinate  $x$ , and in cylindrical coordinates – oscillations, damped by hyperbolic law, along the coordinate  $r$ .

The function of intensity along the axis  $OR$  has the form of sinusoid with monotonically decreasing amplitude.

## 2. The second variant

In contrast to the previous look at a different location of cylindrical coordinates - see Fig. 2, where the axis  $Ox$  is perpendicular to the plane of the figure, the axis  $Ox$  is directed along the radius,  $\varphi$  - the angular coordinate.

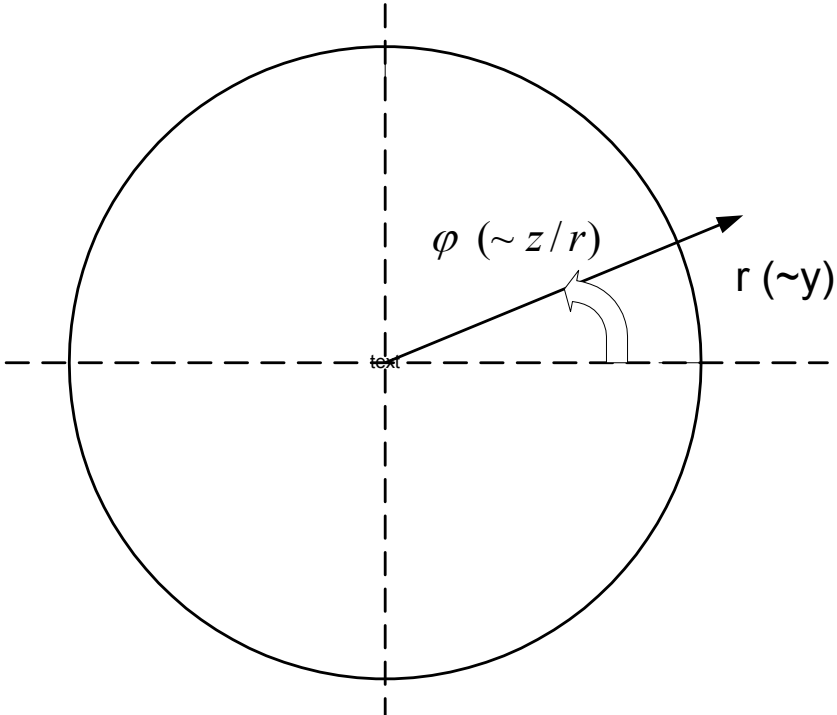

Fig. 2.

In this case Maxwell's equations instead of (9.5.1) take the form:

|    |   |     |
|----|---|-----|
| 1. | $\frac{1}{r} \cdot \frac{\partial(rH_\varphi)}{\partial r} - \frac{1}{r} \cdot \frac{\partial(H_r)}{\partial \varphi} - \varepsilon \frac{\partial E_x}{\partial t} - \vartheta \frac{d(\varphi')}{dx} = 0$ | (1) |
| 2. | $\frac{1}{r} \cdot \frac{\partial(H_x)}{\partial \varphi} - \frac{\partial(H_\varphi)}{\partial x} - \varepsilon \frac{\partial E_r}{\partial t} + \frac{\vartheta}{r} \frac{d(r\varphi')}{dr} = 0$         |     |
| 3. | $\frac{\partial(H_r)}{\partial x} - \frac{1}{r} \cdot \frac{\partial(rH_x)}{\partial r} - \varepsilon \frac{\partial E_\varphi}{\partial t} + \frac{\vartheta}{r} \frac{d\varphi'}{d\varphi} = 0$           |     |
| 4. | $\frac{1}{r} \cdot \frac{\partial(rE_\varphi)}{\partial r} - \frac{1}{r} \cdot \frac{\partial(E_r)}{\partial \varphi} + \mu \frac{\partial H_x}{\partial t} - \zeta \frac{d(\phi)}{dx} = 0$                 |     |

|    |  |
|----|--|
| 5. | $\frac{1}{r} \cdot \frac{\partial(E_x)}{\partial \varphi} - \frac{\partial(E_\varphi)}{\partial x} + \mu \frac{\partial H_r}{\partial t} - \frac{\zeta}{r} \frac{d(r\phi)}{dr} = 0$    |
| 6. | $\frac{\partial(E_r)}{\partial x} - \frac{1}{r} \cdot \frac{\partial(rE_r)}{\partial r} + \mu \frac{\partial H_\varphi}{\partial t} - \frac{\zeta}{r} \frac{d\phi}{d\varphi} = 0$      |
| 7. | $\frac{\partial E_x}{\partial x} + \frac{1}{r} \cdot \frac{\partial(rE_r)}{\partial r} + \frac{1}{r} \cdot \frac{\partial E_\varphi}{\partial \varphi} - \frac{\rho}{\varepsilon} = 0$ |
| 8. | $\frac{\partial H_x}{\partial x} + \frac{1}{r} \cdot \frac{\partial(rH_r)}{\partial r} + \frac{1}{r} \cdot \frac{\partial H_\varphi}{\partial \varphi} - \frac{\sigma}{\mu} = 0$       |

Here the electric potential (contrary to the previous) is denoted as  $\varphi'$ . Formally the transformation (9.5.1) in (1) may be performed according to the rule :

- the coordinates are re-denoted as:

$$x \Rightarrow x, \quad y \Rightarrow r, \quad z \Rightarrow r \cdot \varphi,$$

- the derivatives are re-denoted as:

$$\frac{\partial H}{\partial x} \Rightarrow \frac{\partial H}{\partial x}, \quad \frac{\partial H}{\partial y} \Rightarrow \frac{1}{r} \cdot \frac{\partial(rH)}{\partial r}, \quad \frac{\partial H}{\partial z} \Rightarrow \frac{1}{r} \cdot \frac{\partial H}{\partial \varphi}.$$

This transformation is explained on the Figure 1, where the axis  $ox$  is perpendicular to the plane of the ring, the axis  $oy \Rightarrow or$  is directed along the radius, the axis  $oz \Rightarrow r \cdot \varphi$  - the arc of ring.

## 9.12. Monochromatic Fields

Here we shall consider the intensities of monochromatic fields, the potentials and charges in complex form [51]:

$$\bar{A} = A(x, y, z) e^{i\omega t}, \quad (1)$$

$$\hat{A} = \text{Re}(\bar{A}), \quad (2)$$

where

$\hat{A}$  - true instantaneous values,

$\bar{A}$  - complex values,

$A$  - complex amplitudes,

$\omega$  - angular frequency,

$i$  - imaginary unit.

Let us rewrite the system of symmetrical Maxwell equations (9.5.1) for monochromatic fields in the complex form [51]:

|    |  |     |
|----|--|-----|
| 1. | $\frac{\partial \bar{H}_z}{\partial y} - \frac{\partial \bar{H}_y}{\partial z} - i\omega \varepsilon \bar{E}_x + g \frac{\partial \bar{\phi}}{\partial x} = 0$ | (3) |
| 2. | $\frac{\partial \bar{H}_x}{\partial z} - \frac{\partial \bar{H}_z}{\partial x} - i\omega \varepsilon \bar{E}_y + g \frac{\partial \bar{\phi}}{\partial y} = 0$ |     |
| 3. | $\frac{\partial \bar{H}_y}{\partial x} - \frac{\partial \bar{H}_x}{\partial y} - i\omega \varepsilon \bar{E}_z + g \frac{\partial \bar{\phi}}{\partial z} = 0$ |     |
| 4. | $\frac{\partial \bar{E}_z}{\partial y} - \frac{\partial \bar{E}_y}{\partial z} + i\omega \mu \bar{H}_x - \zeta \frac{\partial \bar{\phi}}{\partial x} = 0$     |     |
| 5. | $\frac{\partial \bar{E}_x}{\partial z} - \frac{\partial \bar{E}_z}{\partial x} + i\omega \mu \bar{H}_y - \zeta \frac{\partial \bar{\phi}}{\partial y} = 0$     |     |
| 6. | $\frac{\partial \bar{E}_y}{\partial x} - \frac{\partial \bar{E}_x}{\partial y} + i\omega \mu \bar{H}_z - \zeta \frac{\partial \bar{\phi}}{\partial z} = 0$     |     |
| 7. | $-\frac{\partial \bar{E}_x}{\partial x} - \frac{\partial \bar{E}_y}{\partial y} - \frac{\partial \bar{E}_z}{\partial z} + \frac{\bar{\rho}}{\varepsilon} = 0$  |     |
| 8. | $\frac{\partial \bar{H}_x}{\partial x} + \frac{\partial \bar{H}_y}{\partial y} + \frac{\partial \bar{H}_z}{\partial z} - \frac{\bar{\sigma}}{\mu} = 0$         |     |

Let us remind that here

$\mu$  - magnetic permeability,

$\varepsilon$  - dielectric permittivity,

$\rho$  - electric charge density,

$\sigma$  - hypothetic magnetic charge density,

$\mathbf{j} = \text{grad}(K)$  - electric current density,

$\mathbf{m} = \text{grad}(L)$  - hypothetic magnetic current density,

$\varphi$  - electric scalar potential,

$\phi$  - hypothetic magnetic scalar potential,

$\mathcal{G}$  - electrical conductivity,

$\zeta$  - hypothetic magnetic conductivity.

The equations (3) may be rewritten in abbreviated form:

$$\text{rot}\bar{H} - i\omega\varepsilon\bar{E} + \theta\bar{\varphi} = 0, \quad (4)$$

$$\text{rot}\bar{E} + i\omega\mu\bar{H} - \zeta\bar{\phi} = 0, \quad (5)$$

$$\text{div}\bar{E} - \bar{\rho}/\varepsilon = 0, \quad (6)$$

$$\text{div}\bar{H} - \bar{\sigma}/\mu = 0. \quad (7)$$

Let us denote

$$\tilde{E} = i\bar{E}, \quad (8)$$

$$\tilde{\rho} = i\bar{\rho}. \quad (9)$$

and rewrite (4-7) in the form

$$\text{rot}\bar{H} - \omega\varepsilon\tilde{E} + \theta\bar{\varphi} = 0, \quad (10)$$

$$-\text{rot}\bar{E} + \omega\mu\bar{H} - \zeta\bar{\phi} = 0, \quad (11)$$

$$\text{div}\tilde{E} - \tilde{\rho}/\varepsilon = 0, \quad (12)$$

$$\text{div}\bar{H} - \bar{\sigma}/\mu = 0. \quad (13)$$

Evidently, the complex amplitudes for  $\tilde{E}$ ,  $\bar{E}$  are identical and equal to  $E$ . Also the complex amplitudes for  $\tilde{\rho}$ ,  $\bar{\rho}$  are identical and equal to  $\rho$ . Therefore, (10-13) may be rewritten as follows after discarding the common factors  $e^{i\omega t}$ :



$$\operatorname{rot} H - \omega \varepsilon E + \theta \varphi = 0, \quad (14)$$

$$-\operatorname{rot} E + \omega \mu H - \zeta \phi = 0, \quad (15)$$

$$\operatorname{div} E - \rho / \varepsilon = 0, \quad (16)$$

$$\operatorname{div} H - \sigma / \mu = 0. \quad (17)$$

This equations system may be solved by the aforesaid methods. After its solution the complex values of the variables are determined as

$$\bar{E} = i \cdot E \cdot e^{i\omega t},$$

$$\bar{H} = H \cdot e^{i\omega t},$$

$$\bar{\varphi} = \varphi \cdot e^{i\omega t},$$

$$\bar{\phi} = \phi \cdot e^{i\omega t},$$

$$\bar{\rho} = i \cdot \rho \cdot e^{i\omega t},$$

$$\bar{\sigma} = \sigma \cdot e^{i\omega t}.$$

### 9.13. The Static Electric and Magnetic Fields

Here we shall consider plane static electric and magnetic fields that emerge around a charged plate, the end of a permanent magnet or a plane conductor. It will be shown that the intensities of such fields give a minimum to a certain functional. We also are presenting a method for calculation of such fields, consisting in gradient descent along this functional [54].

#### 1. The Electric Field of a Charged Infinite Strip

The Maxwell equations for electrostatics are as follows:

$$\operatorname{div}(E) = \frac{\rho}{\varepsilon}, \tag{1}$$

$$\operatorname{rot}(E) = 0, \tag{2}$$

where

$\varepsilon$  - absolute permittivity of the environment

$\rho$  - density of charges.

Let the charged plate has a form of infinite strip – see Fig. 1.



Рис. 1.

In this case the intensity  $E_z = 0$  and electrostatic equations take the form

$$\frac{\partial E_x}{\partial x} + \frac{\partial E_y}{\partial y} = \frac{\rho}{\varepsilon}, \tag{3}$$

$$\frac{\partial E_y}{\partial x} - \frac{\partial E_x}{\partial y} = 0, \quad (4)$$

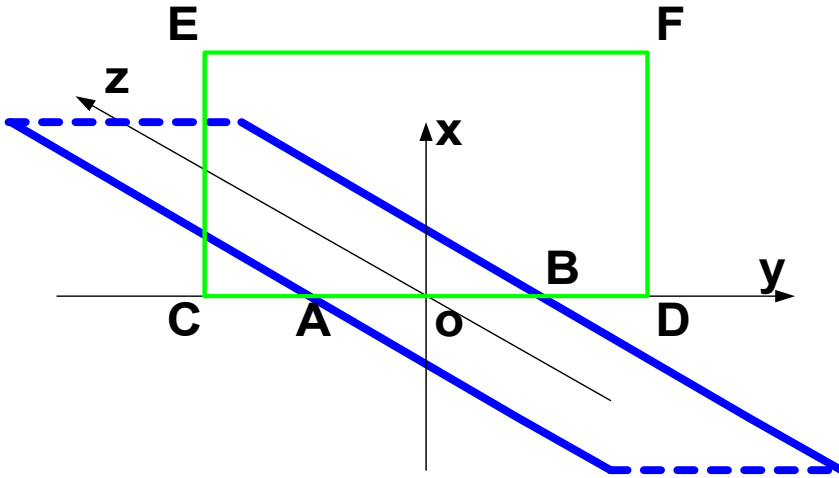
as in this case

$$\operatorname{div}(E) = \left( \frac{\partial E_x}{\partial x} + \frac{\partial E_y}{\partial y} \right), \quad (5)$$

$$\operatorname{rot}(E) = \left( \frac{\partial E_y}{\partial x} - \frac{\partial E_x}{\partial y} \right). \quad (6)$$

## 2. The Variational Principle for Plane Static Electric Fields

Let us consider a functional

$$F(q) = \int_x \left( \frac{1}{2} L \cdot \left( \frac{dq}{dx} \right)^2 + \rho \cdot \frac{dq}{dx} \right) dx. \quad (1)$$

from a function  $q(x)$ , where  $L$  is a known constant, and  $\rho(x)$  – a known function. The extremal of this functional is described by an equation of the form:

$$-L \cdot \left( \frac{d^2 q}{dx^2} \right) - \frac{d\rho}{dx} = 0. \quad (2)$$

or, after integrating,

$$L \cdot \frac{dq}{dx} + \rho + \text{const} = 0. \quad (3)$$

Therefore, when descending on this functional along its gradient

$$p = -L \cdot \left( \frac{d^2 q}{dx^2} \right) - \frac{d\rho}{dx} \quad (4)$$

the optimal value of the function  $q(x)$  will be found, satisfying the equation (3).

Let us now consider a vector-function

$$E = \underline{[E_x(x, y), E_y(x, y)]} \quad (5)$$

and the following functional

$$F(E) = \iint_{x,y} \left( \begin{aligned} &\frac{1}{2} E_y \cdot \partial(\text{grad}(E_x))/\partial y + \frac{1}{2} E_x \cdot \partial(\text{grad}(E_y))/\partial y \\ &+ E_x \cdot \partial(\text{grad}(E_x))/\partial x - E_y \cdot \Delta(E_y) + \frac{\rho}{\varepsilon} \cdot \text{div}(E_x) \end{aligned} \right) dx dy \quad (6a)$$

or

$$F(E) = \iint_{x,y} \left( \begin{aligned} &\frac{1}{2} E_y \cdot \left( \frac{\partial^2 E_x}{\partial y^2} + \frac{\partial^2 E_x}{\partial x \partial y} \right) + \frac{1}{2} E_x \cdot \left( \frac{\partial^2 E_y}{\partial y^2} + \frac{\partial^2 E_y}{\partial x \partial y} \right) \\ &+ E_x \cdot \left( \frac{\partial^2 E_x}{\partial x^2} + \frac{\partial^2 E_x}{\partial x \partial y} \right) - E_y \cdot \left( \frac{\partial^2 E_y}{\partial x^2} + \frac{\partial^2 E_y}{\partial y^2} \right) \\ &+ \frac{\rho}{\varepsilon} \cdot \left( \frac{\partial E_x}{\partial x} + \frac{\partial E_x}{\partial y} \right) \end{aligned} \right) dx dy, \quad (6b)$$

where  $\rho(x, y)$  is a known function.

Now we shall reason by analogy with the aforesaid. According to Ostrogradsky formula [16] it is easy to show that the extremal of this functional is described by two equations – extremals by the functions  $E_x(x, y)$ ,  $E_y(x, y)$ :

$$\left( \frac{\partial^2 E_y}{\partial y^2} + \frac{\partial^2 E_y}{\partial x \partial y} + \frac{\partial^2 E_x}{\partial x \partial y} + \frac{\partial^2 E_x}{\partial x^2} + \frac{1}{\varepsilon} \cdot \left( \frac{\partial \rho}{\partial x} + \frac{\partial \rho}{\partial y} \right) \right) = 0, \quad (7)$$

$$\left( \frac{\partial^2 E_x}{\partial y^2} + \frac{\partial^2 E_x}{\partial x \partial y} - \frac{\partial^2 E_y}{\partial x^2} - \frac{\partial^2 E_y}{\partial x \partial y} \right) = 0.$$

Here the first two members in both equations are the result of differentiation, according to Ostrogradsky theorem, of the two first members of the functional; the third and the fourth members in the first equation are the result of differentiating the third summand of the functional; the third and fourth members of the second equation are the result of differentiating the fourth summand of the functional; the fifth member of the first equation is the result of differentiating the fifth summand of the functional.. Taking into account (1.5, 1.6), the equations (7) are transformed into the form:

$$\left( \begin{array}{l} \text{grad}(\text{div}(E)) + \frac{1}{\varepsilon} \cdot \text{grad}(\rho) = 0, \\ \text{grad}(\text{rot}(E)) = 0. \end{array} \right). \quad (8)$$

Since the field  $E$  does not have a permanent component, from (8) follows (1.1, 1.2). Therefore, the descent on the functional (6a) in the direction of gradient

$$p = \left( \begin{array}{l} p_x \\ p_y \end{array} \right) = \left( \begin{array}{l} \text{grad}(\text{div}(E)) + \frac{1}{\varepsilon} \cdot \text{grad}(\rho) = 0 \\ \text{grad}(\text{rot}(E)) = 0 \end{array} \right). \quad (9)$$

will give us the optimal value of the function  $E(x, y)$ , satisfying the Maxwell equations  $\text{Максвелла}$  (1.1, 1.2) or (1.3, 1.4).

### 3. The Magnetic Field Around an Elongated End of a Permanent Magnet

Let us consider a permanent strip magnet, magnetized in the direction of the strip thickness – Fig. 1 shows such a construction. The Maxwell equations around the end-strip of such magnet are:

$$\text{div}(H) = \frac{\sigma}{\varepsilon}, \quad (1)$$

$$\text{rot}(H) = 0, \quad (2)$$

where

$\mu$  - the absolute permeability of the environment,

$\sigma$  - the density of magnetic charges, which is equal to the induction on the magnet end.

These equations and the equations of the electric field of a charged strip are identical up to the notations and constants. It means that for the calculation of such magnetic field the aforesaid method can be used.

### 4. The Magnetic Field of a Strip Conductor

We shall assume that the conductor carrying a constant current, is formed as an infinite strip along the  $z$  coordinate – see Fig. 1. Then the intensity  $H_z = 0$  and Maxwell equations will take the following form:

$$\frac{\partial H_x}{\partial x} + \frac{\partial H_y}{\partial y} = 0, \quad (1)$$

$$\frac{\partial H_y}{\partial x} - \frac{\partial H_x}{\partial y} - \frac{dK}{dz} / \mu = 0, \quad (2)$$

where

- axis  $ox$  is directed perpendicular to the plane of the strip,
- axis  $oy$  is directed across the strip,
- axis  $oz$  is directed along the strip,
- electric current density

$$\mathbf{j} = \text{grad}(K). \quad (3)$$

- $\mu$  - absolute magnetic permeability.

We denote

$\varphi$  - electric scalar potential,

$\mathcal{G}$  - electrical conductivity,

$j_z$  - projection of vector of electric current density  $\mathbf{j}$  on the axis  $oz$ .

Then we shall get

$$j_z = \frac{dK}{dz}, \quad (4)$$

$$j_z = -\mathcal{G} \frac{d\varphi}{dz}, \quad (5)$$

$$\frac{dK}{dx} = -\mathcal{G} \frac{d\varphi}{dx}, \quad (6)$$

$$K = -\mathcal{G}\varphi. \quad (7)$$

Let us rewrite the equation (2) as

$$\frac{\partial H_y}{\partial x} - \frac{\partial H_x}{\partial y} - J/\mu = 0, \quad (8)$$

where  $J$  is the projection of the vector of constant current density to the plane  $xoy$ .

## 5. Variational Principle for a Strip Conductor

The equations (4.1, 4.8) may be written as

$$\text{div}(\mathbf{H}) = 0, \quad (1)$$

$$\text{rot}(\mathbf{H}) - \mathbf{J}/\mu = 0. \quad (2)$$

By analogy with Section 2 let us consider the following functional

$$F(E) = \iint_{x,y} \left( \frac{1}{2} H_y \cdot \text{grad}(H_x) / \partial y + \frac{1}{2} H_x \cdot \text{grad}(H_y) / \partial x + H_x \cdot \text{grad}(H_x) / \partial x - H_y \cdot \Delta(H_y) - \frac{J}{\varepsilon} \cdot \text{div}(H_y) \right) dx dy, \quad (3)$$

where  $J(x, y)$  is a known function. The extremal of this functional is described by two equations – extremals by the functions  $H_x(x, y), H_y(x, y)$ :

$$\left( \begin{array}{l} \text{grad}(\text{div}(H)) = 0, \\ \text{grad}(\text{rot}(H)) - \frac{1}{\mu} \cdot \text{grad}(J) = 0. \end{array} \right). \quad (4)$$

Since the field  $H$  does not have a permanent component, from (4) follow (1, 2). Therefore, the descent on the functional (3) in the direction of gradient

$$p = \begin{pmatrix} p_x \\ p_y \end{pmatrix} = \begin{pmatrix} \text{grad}(\text{div}(H)) + \frac{1}{\mu} \cdot \text{grad}(J) = 0 \\ \text{grad}(\text{rot}(H)) = 0 \end{pmatrix}. \quad (5)$$

находится оптимальное значение функции  $H(x, y)$ , удовлетворяющее уравнениям Максвелла (1, 2).

## 6. Variational Principle for Three-dimensional Static Electric Fields

The Maxwell equations for electrostatics in this case also will be of the form (1.1, 1.2). But in this case they turn into 4 equations with respect to three unknown functions  $E_x(x, y, z), E_y(x, y, z), E_z(x, y, z)$ :

$$\frac{\partial E_x}{\partial x} + \frac{\partial E_y}{\partial y} + \frac{\partial E_z}{\partial z} = \frac{\rho}{\varepsilon}, \quad (1)$$

$$\frac{\partial E_y}{\partial x} - \frac{\partial E_x}{\partial y} = 0, \quad (2)$$

$$\frac{\partial E_z}{\partial x} - \frac{\partial E_x}{\partial z} = 0, \quad (3)$$

$$\frac{\partial E_y}{\partial z} - \frac{\partial E_z}{\partial y} = 0. \quad (4)$$

This system formally is overdetermined. But in the case of axisymmetric structure (around the  $Ox$  axis) the equation (4) becomes an identity and may be excluded. Further we shall consider only such structures (although, generally speaking, the overdetermining is excluded even in the general case – in numerical modeling the solution found by (1-3), satisfies the equation (4)). In such structure, described by two equations (2, 3) the rotor will be denoted by  $\text{rot}_0(E) = 0$ .

By analogy with Section 2 let us consider the functional

$$F(E) = \iint_{x,y} \left( \begin{aligned} &\frac{1}{2} E_y \cdot \partial(\text{grad}(E_x))/\partial y + \frac{1}{2} E_x \cdot \partial(\text{grad}(E_y))/\partial y + \\ &\frac{1}{2} E_z \cdot \partial(\text{grad}(E_x))/\partial z + \frac{1}{2} E_x \cdot \partial(\text{grad}(E_z))/\partial z + \\ &E_x \cdot \partial(\text{grad}(E_x))/\partial x - E_y \cdot \Delta(E_y) - E_z \cdot \Delta(E_z) \\ &+ \frac{\rho}{\varepsilon} \cdot \text{div}(E_x) \end{aligned} \right) dx dy, \quad (12)$$

where  $\rho(x, y)$  is a known function. By analogy with the aforesaid we may show that the extremal of this functional is described by three equations—extremals by the functions—extremals  $E_x(x, y, z)$ ,  $E_y(x, y, z)$ ,  $E_z(x, y, z)$ :

$$\left( \begin{aligned} &\text{grad}(\text{div}(E)) - \frac{1}{\varepsilon} \cdot \text{grad}(\rho) = 0, \\ &\text{grad}(\text{rot}_0(E)) = 0. \end{aligned} \right). \quad (13)$$

Since the field  $E$  does not have a permanent component, from (13) follow (1, 2, 3). Therefore, the descent on the functional (12) in the direction of gradient

$$p = \begin{pmatrix} p_x \\ p_y \\ p_z \end{pmatrix} = \begin{pmatrix} \text{grad}(\text{div}(E)) - \frac{1}{\varepsilon} \cdot \text{grad}(\rho) = 0 \\ \text{grad}(\text{rot}_0(E)) = 0 \end{pmatrix}. \quad (14)$$

will give us the optimal value of the function  $E(x, y, z)$ , satisfying the Maxwell equations Максвелла (1, 2, 3).

In the same way we can build a functional for static magnetic fields, formed by magnet's ends or by plane conductors.



# Chapter 10. Principle extremum of full action

## 1. The Principle Formulation

The Lagrange formalism is widely known – it is an universal method of deriving physical equations from the principle of least action. The action here is determined as a definite integral - functional

$$S(q) = \int_{t_1}^{t_2} (K(q) - P(q)) dt \quad (1)$$

from the difference of kinetic energy  $K(q)$  and potential energy  $P(q)$ , which is called Lagrangian

$$\Lambda(q) = K(q) - P(q). \quad (2)$$

Here the integral is taken on a definite time interval  $t_1 \leq t \leq t_2$ , and  $q$  is a vector of generalized coordinates, dynamic variables, which, in their turn, are depending on time. The principle of least action states that the extremals of this functional (ie equations in which it takes its minimum value), on which it reaches its minimum, are equations of real dynamic variables (i.e. existing in reality).

For example, if the energy of system depends only on functions  $q$  and their derivatives with respect to time  $q'$ , then the extremal is determined by the Euler formula [16]

$$\frac{\partial(K - P)}{\partial q} - \frac{d}{dt} \left( \frac{\partial(K - P)}{\partial q'} \right) = 0. \quad (3)$$

The Lagrange formalism is applicable to those systems where the full energy (the sum of kinetic and potential energies) is kept constant. The principle does not reflect the fact that in real systems the full energy (the sum of kinetic and potential energies) decreases during motion, turning into other types of energy, for example, into thermal energy  $Q$ , i. e. there occurs energy dissipation. The fact, that for dissipative systems (i.e., for system with energy dissipation) there is no formalism similar to Lagrange formalism, seems to be strange: so the physical world is found to be divided to a harmonious (with the principle of least action) part, and a chaotic ("unprincipled") part.

The author puts forward the **principle extremum of full action**, applicable to dissipative systems. We propose calling full action a definite integral – the functional

$$\Phi(q) = \int_{t_1}^{t_2} \mathfrak{R}(q) dt \quad (4)$$

from the value

$$\mathfrak{R}(q) = (K(q) - P(q) - Q(q)), \quad (5)$$

which we shall call Energian. In it  $Q(q)$  is the thermal energy. Further we shall consider a full action quasiextremal, having the form:

$$\frac{\partial(K - P)}{\partial q} - \frac{d}{dt} \left( \frac{\partial(K - P)}{\partial q'} \right) - \frac{\partial Q}{\partial q} = 0. \quad (6)$$

Functional (4) reaches its extremal value (*defined further*) on quasiextremals. The principle extremum of full action states that the quasiextremals of this functional are equations of real dynamic processes

Right away we must note that the extremals of functional (4) coincide with extremals of functional (1) - disappears term, corresponding to  $Q(q)$ .

Let us determine the extremal value of functional (5). For this purpose we shall "split" (ie replace) the function  $q(t)$  into two independent functions  $x(t)$  and  $y(t)$ , and the functional (4) will be associated with functional

$$\Phi_2(x, y) = \int_{t_1}^{t_2} \mathfrak{R}_2(x, y) dt, \quad (7)$$

which we shall call "split" full action. The function  $\mathfrak{R}_2(x, y)$  will be called "split" Energian (by analogy with the Lagrangian). This functional is minimized along function  $x(t)$  with a fixed function  $y(t)$  and is maximized along function  $y(t)$  with a fixed function  $x(t)$ . The minimum and the maximum are sole ones. Thus, the extremum of functional (7) is a saddle line, where one group of functions  $x_0$  minimizes the functional, and another -  $y_0$ , maximizes it. The sum of the pair of optimal values of the split functions gives us the sought function  $q = x_0 + y_0$ , satisfying the quasiextremal equation (6). In other words, the quasiextremal of the functional (4) is a sum of extremals  $x_0, y_0$  of functional (7), determining the saddle point of this

functional. It is important to note that this point is the sole extremal point – there is no other saddle points and no other minimum or maximum points. Therein lies the essence of the expression "extremal value on quasiextremals". Our **statement 1** is as follows:

In every area of physics we may find correspondence between full action and split full action, and by this we may prove that full action takes global extremal value on quasiextremals.

Let us consider the relevance of statement 1 for several fields of physics.

## 2. Electrical Engineering

Full action in electrical engineering takes the form (1.4, 1.5), where

$$K(q) = \frac{Lq'^2}{2}, \quad P(q) = \left( \frac{Sq^2}{2} - Eq \right), \quad Q(q) = Rq'q. \quad (1)$$

Here stroke means derivative,  $q$  - vector of functions-charges with respect to time,  $E$  - vector of functions-voltages with respect to time,  $L$  - matrix of inductivities and mutual inductivities,  $R$  - matrix of resistances,  $S$  - matrix of inverse capacities, and functions  $K(q)$ ,  $P(q)$ ,  $Q(q)$  present magnetic, electric and thermal energies correspondingly. Here and further vectors and matrices are considered in the sense of vector algebra, and the operation with them are written in simplified form. Thus, a product of vectors is a product of column-vector by row-vector, and a quadratic form, as, for example,  $Rq'q$  is a product of row-vector  $q'$  by quadratic matrix  $R$  and by column-vector  $q$ .

It was shown above that such interpretation is true for any electrical circuit

The equation of quasiextremal in this case takes the form:

$$Sq + Lq'' + Rq' - E = 0. \quad (2)$$

Let us (1) в (1.5), write the Energian (1.5) in an expanded form

$$\mathfrak{R}(q) = \left( \frac{Lq'^2}{2} - \frac{Sq^2}{2} + Eq - Rq'q \right). \quad (3)$$

Let us present the split Energian in the form

$$\mathfrak{R}_2(x, y) = \left[ \begin{array}{l} (Ly'^2 - Sy^2 + Ey - Rxy') \\ (Lx'^2 - Sx^2 + Ex - Rx'y) \end{array} \right]. \quad (4)$$

Here the extremals of integral (1.7) by functions  $x(t)$  and  $y(t)$ , found by Euler equation, will assume accordingly the form:

$$2Sx + 2Lx'' + 2Ry' - E = 0, \quad (5)$$

$$2Sy + 2Ly'' + 2Rx' - E = 0. \quad (6)$$

By symmetry of equations (5, 6) it follows that optimal functions  $x_0$  and  $y_0$ , satisfying these equations, satisfy also the condition

$$x_0 = y_0. \quad (7)$$

Adding the equations (5) and (6), we get equation (2), where

$$q = x_0 + y_0. \quad (8)$$

It was shown above, that conditions (5, 6) are necessary for the existence of a sole saddle line. It was also shown above that sufficient condition for this is that the matrix  $L$  has a fixed sign, which is true for any electric circuit.

Thus, the statement 1 for electrical engineering is proved. From it follows also **statement 2**:

Any physical process described by an equation of the form (2), satisfies the principle extremum of full action.

### 3. Mechanics

Here we shall discuss only one example - line motion of a body with mass  $m$  under the influence of a force  $f$  and drag force  $kq'$ , where  $k$  - known coefficient,  $q$  - body's coordinate. It is well known that

$$f = mq'' + kq'. \quad (1)$$

In this case the kinetic, potential and thermal energies are accordingly:

$$K(q) = mq'^2/2, \quad P(q) = -fq, \quad Q(q) = kqq'. \quad (2)$$

Let us write the Energian (1.5) for this case:

$$\mathfrak{R}(q) = mq'^2/2 + fq - kqq'. \quad (3)$$

The equation for Energian in this case is (1)

Let us present the split Energian as:

$$\mathfrak{R}_2(x, y) = \left[ \begin{array}{l} (my'^2 + fy - kxy') \\ (mx'^2 + fx - kx'y') \end{array} \right]. \quad (4)$$

It is easy to notice an analogy between Energians for electrical engineering and for this case, whence it follows that Statement 1 for this case is proved. However, it also follows directly from Statement 2.

## 4. Electrodynamics

Further instead of the general-action extremum principle with regard to energies we shall discuss the similar general-action extremum principle with regard to powers.

### 4.1. The power balance of electromagnetic field

The equation of electromagnetic field power balance in differential form is well known [48]. It has the following form

$$P_{\Pi} + P_{EH} + P_Q + P_C = 0, \quad (1)$$

where

$P_{\Pi}$  - the density of power flow through a certain surface ,

$P_{EH}$  - the density of electromagnetic power of an electromagnetic field,

$P_Q$  - the density of heat loss power,

$P_C$  - the density of outside current sources power.

Also

$$P_{\Pi} = \operatorname{div}[E \times H] \quad (2)$$

or, according to a known formula of vector analysis,

$$P_{\Pi} = E \cdot \operatorname{rot}(H) - H \cdot \operatorname{rot}(E), \quad (3)$$

$$P_{EH} = \mu H \frac{dH}{dt} + \varepsilon E \frac{dE}{dt}, \quad (4)$$

$$P_Q = J_1 E, \quad (5)$$

$$P_C = J_2 E, \quad (6)$$

where

$\varepsilon$  - absolute permittivity,

$\mu$  - absolute magnetic permeability,

$J_1$  - the density of conduction current,

$J_2$  - the current density of outside current source.

Here and further the three-component vectors

$H, \frac{dH}{dt}, E, \frac{dE}{dt}, J_1, J_2, \text{rot}(H), \text{rot}(E)$  are considered vectors in

the sense of vector algebra. So the operations of multiplication for them may be written in simplified form. For instance, a product of vectors  $E \cdot \text{rot}(H)$  is a product of column-vector  $E$  by row-vector  $\text{rot}(H)$ .

Let us denote

$$J = J_1 + J_2, \quad (7)$$

$$P_J = P_Q + P_C. \quad (8)$$

$$J = \text{grad}(K), \quad (9)$$

where  $K$  is a scalar potential. From (5-9) it follows, that the power of an electric current

$$P_J = E \cdot \text{grad}(K). \quad (10)$$

The charges in the field of scalar potential possess potential energy. The corresponding power

$$P_\rho = K\rho/\varepsilon, \quad (11)$$

where  $\rho$  - distribution density of summary (free and outside) charges.

Let us assume now, that there exist magnetic charges with density distribution  $\sigma$  and magnetic currents

$$M = \text{grad}(L), \quad (12)$$

where  $L$  is a scalar parameter. Then by symmetry we should assume that there exists magnetic current power

$$P_M = H \cdot \text{grad}(L), \quad (13)$$

potential energy of magnetic charges and the corresponding power

$$P_\sigma = L\sigma/\mu, \quad (14)$$

where  $\sigma$  - density of magnetic charges.

Let us denote also the summary currents power (electric and magnetic)

$$P_{JM} = P_J + P_M. \quad (15)$$

and the total power of charges (electric and magnetic)

$$P_{\rho\sigma} = P_\rho + P_\sigma. \quad (16)$$

Then the equation of power balance of electromagnetic field takes the form:

$$P_{\Pi} + P_{EH} + P_{JM} + P_{\rho\sigma} = 0, \quad (18)$$

where the components are determined as (3, 4, 15, 16) accordingly.

#### 4.2. Building the functional for Maxwell equations

Let us consider a electromagnetic field of volume  $V$ , limited by surface  $S$ . Full action in electrodynamics has such a form

$$\Phi = \int_0^T \left\{ \oint_V \{ P_{EH} - P_{JM} - P_{\rho\sigma} \} dV - \oint_S \Pi dS \right\} dt, \quad (21)$$

Here we have in mind that the volume density of the power of electromagnetic field  $P_{EH}$  is determined from (4), the volume density of the total power of the currents is determined from (15, 16), and the Pointing vector is

$$\Pi = [E \times H]. \quad (22)$$

Here the first component is the electromagnetic field in volume  $V$ , the second component is the currents power in volume  $V$ , and the third component is the power of the charges in the volume  $V$ , and the fourth component is the instantaneous value of density of power flow through surface  $S$ .

По теореме Остроградского имеем:

$$\oint_V \operatorname{div}[E \times H] dV = \oint_S [E \times H] dS. \quad (23)$$

Taking regard of formulas (2, 22), from (21) we get:

$$\Phi = \int_0^T \left\{ \oint_z \left\{ \oint_y \left\{ \oint_x \{ P_{EH} - P_{\Pi} - P_{JM} - P_{\rho\sigma} \} dx \right\} dy \right\} dz \right\} dt \quad (24)$$

or

$$\Phi = \int_0^T \left\{ \oint_z \left\{ \oint_y \left\{ \oint_x \mathfrak{R}(q(x, y, z, t) dx \right\} dy \right\} dz \right\} dt, \quad (25)$$

where  $q$  - the vector of unknown functions  $(E, H, K, L)$ , and the Energian for electrodynamics has the form:

$$\mathfrak{R}(q) = \{ P_{EH} - P_{\Pi} - P_{JM} - P_{\rho\sigma} \} \quad (26)$$

Taking regard of formula (4, 3, 18), we get

$$\mathfrak{R}(q) = \left\{ \begin{array}{l} H \cdot \text{rot}(E) - E \cdot \text{rot}(H) + \mu H \frac{dH}{dt} + \varepsilon E \frac{dE}{dt} - \\ - \left( E \cdot \text{grad}(K) + \frac{K\rho}{\varepsilon} \right) - \left( H \cdot \text{grad}(L) + \frac{L\sigma}{\mu} \right) \end{array} \right\}. \quad (27)$$

Let us remind that the necessary conditions of extremum for a functional from functions of several independent variables - the Ostrogradsky equations [16] for each function have the form (9.1.1.1a).

Let us consider a vector of unknown scalar functions of four variables  $(x, y, z, t)$ :

$$q = [E_x, E_y, E_z, H_x, H_y, H_z, K, L]. \quad (27B)$$

Let us write the equation of quasiextremal for the functional (27) for each  $i$ -th component  $q_i$  of the vector  $q$

$$\left\{ \begin{array}{l} \frac{\partial P_{JM}}{\partial q_i} - \sum_{a=x,y,z,t} \left[ \frac{d}{da} \left( \frac{\partial P_{JM}}{\partial [dq_i/da]} \right) \right] \\ + \frac{\partial P_{\rho\sigma}}{\partial q_i} + \frac{\partial P_{\Pi}}{\partial q_i} + \frac{\partial P_{EH}}{\partial q_i} \end{array} \right\} = 0. \quad (28)$$

The first four components here corresponds to Ostrogradsky equation (9.1.1.1a), and two others are ordinary partial derivatives. Differentiating by unknown functions according to (28), and combining then the three projections into a vector, we get:

- By variable  $E = [E_x, E_y, E_z]$ :

$$-\text{rot}H + \varepsilon \frac{dE}{dt} - \text{grad}(K) = 0, \quad (29)$$

- By variable  $H = [H_x, H_y, H_z]$ :

$$\text{rot}E + \mu \frac{dH}{dt} - \text{grad}(L) = 0, \quad (30)$$

- By variables  $K, L$  accordingly,

$$\left( \text{div}E - \frac{\rho}{\varepsilon} \right) = 0, \quad \left( \text{div}H - \frac{\sigma}{\mu} \right) = 0. \quad (31)$$

We may notice that these equations are symmetrical Maxwell equations (since they have more magnetic charges, the scalar potentials and currents).



### 4.3. Splitting the functional for Maxwell equations

Let us associate with the functional (25) the functional on split full action

$$\Phi_2 = \int_0^T \left\{ \oint_z \left\{ \oint_y \left\{ \oint_x \mathfrak{R}_2(q', q'') dx \right\} dy \right\} dz \right\} dt, \quad (32)$$

Let us present the split Energian in the form

$$\mathfrak{R}_2(q', q'') = \left\{ \begin{array}{l} \frac{1}{2} (H' \cdot \text{rot}(E') + E' \cdot \text{rot}(H')) \\ - \frac{1}{2} (H'' \cdot \text{rot}(E'') + E'' \cdot \text{rot}(H'')) + \\ \frac{\mu}{2} \left( H' \frac{dH''}{dt} - H'' \frac{dH'}{dt} \right) - \frac{\varepsilon}{2} \left( E' \frac{dE''}{dt} - E'' \frac{dE'}{dt} \right) \\ - \left( E' \cdot \text{grad}(K') + \frac{K'\rho}{\varepsilon} \right) + \left( E'' \cdot \text{grad}(K'') + \frac{K''\rho}{\varepsilon} \right) \\ - \left( H' \cdot \text{grad}(L') + \frac{L'\sigma}{\mu} \right) + \left( H'' \cdot \text{grad}(L'') + \frac{L''\sigma}{\mu} \right) \end{array} \right\} \quad (33)$$

Above it was proved that the extremals of integral (32) by functions  $q', q''$ , found from Ostrogradsky equation, are the necessary and sufficient conditions of the existence of a sole saddle line, and the optimal functions  $q'_o, q''_o$ , satisfying these extremals, satisfy also the condition

$$q'_o = q''_o. \quad (34)$$

Adding these extremals, we shall get the Maxwell equations system (29-31), where

$$q = q'_o + q''_o. \quad (35)$$

- see (27B). Consequently, the Statement 1 for electrodynamics is proved.

## 5. Principle extremum of full action for hydrodynamics

This principle is discussed in detail in [53]. The hydrodynamic equations for a viscous incompressible and compressible fluid follow from it.

## 6. Computational Aspect

Thus, the proposed variational principle permits to build for various physical systems a functional with a sole optimal saddle line. We have also proposed a computational method of moving to the saddle line, which permits to find quasiextremals of this functional. In this way we are able to determine real equations for a given physical system.

Therefore the new formalism is not only an universal method of deducing physical equations according to a certain principle, but also a computational approach to the building of these equations.

---

# References

---

1. Maxwell J.C. Treatise of Electricity and Magnetism, V. 1. M.: Nauka, 1989, p. 328 (in Russian)
2. Dennis J.B. Mathematical Programming and Electrical Networks, New York, 1959, Pages V1, 186 p.
3. Penfield P., Spence R., Duinker S. Tellegen's Theorem and Electrical Networks, Cambridge, Mass., 1970, Pages XV, 143 p.
4. Obratsov I.F., Gvishiani A.D., Gurvich V.A. Circuits Calculation and Dual Problems of Convex Programming. Doklady Akademii Nauk SSSR, 287, №5, Mathematics, 1986, 48-52 p. (in Russian)
5. White D., Woodson G. Electromechanical Energy Conversion L.: Energia 1964, 281 p. (in Russian)
6. Lazebnik A.I., Levitin E.S., Khranovich I.L. About Variational Principles of Electrical Circuits. Interdepartmental Collection of Articles of the Republic Ukraine, issue 18, Lvov: publication of Lvov University 1975, 85-91 p. (in Russian)
7. Tzlaff L. Calculus of Variations and Integral Equations. M.: Nauka, 1966, 254 p. (in Russian)
8. Khmel'nik S.I. Maximum Principle for Alternating Current Electrical Circuits M.: Power Industry All-Union Research Institute, deposited in Informelectro№ 2960-EI-88, 1988, 26 p. (in Russian)
9. Khmel'nik S.I. Variational Principles in Electric Models of Continuous Mediums The Problems of Technical Hydrodynamics. Collection of Articles. M.: Nauka, 1991, 148-158 p. (in Russian)
10. Khmel'nik S. Program System for Alternating Current Electromechanical Systems IV International Conference "Creative Search of Israeli Scientists Today" Israel, Ashkelon, 1999, 148-155 p.
11. Zangvill U.I. Nonlinear Programming. Unified Approach M.: Sovetskoe Radio 1973, 312 p. (in Russian)
12. Herman E. Koenig, William A. Blackwell. Electromechanical System Theory, McGraw-Hill Book Company, N.Y., 1961.
13. Khmel'nik S.I. Direct Current Electric Circuit for Simulation and Control. Algorithms and Hardware. Published by "MiC" - Mathematics in Computer Comp., printed in USA, Lulu Inc.,

- second edition, ID 293359, Israel-Russia, 2006, 177 p. ISBN 978-1-4452-0994-4 (in Russian)
14. Andre Angou. Mathematics for Electrical and Radio Engineers M.: “Nauka”, 1964, 772 p. (in Russian)
  15. Khmelnik S.I. The Principle of Extremum in Electric Circuits, <http://www.laboratory.ru>, 2004
  16. Elsgoltz L.E. Differential Equations and Calculus of Variations, Editorial URSS, Moscow, 2000 (in Russian).
  17. Khmelnik S.I. Extremum Principle In Electric Circuits. Raising the Power Systems Efficiency: IGEU transactions. Issue 6. M.: Energoatomizdat, 2003, cc. 325-333, ISBN 5-283-02595-0 (in Russian)..
  18. Pontryagin L.S., Boltyansky V.G., Gamkrelidze R.V., Mishchenko E.F., Mathematical Theory of Optimal Processes, publ. «Nauka», M., 1969, pp. 23-26. , (in Russian).
  19. Valyakh E. Parallel-Serial Computations. Moscow, “Mir”, 1985.-456p.
  20. Shevtsov G.S. Linear Algebra. M.: Gardariki, 1999.-360p.
  21. Bessonov L. A. Linear Electric Circuits. Moscow, publ. house “Vysshaya Shkola”, 1983.
  22. Krasnov M.L., Kiselev A.I., Makarenko U.I., Shikin E.V., Zalyapin V.I., Sobolev S.K. All the Higher Mathematics”, volume 4, Editorial URSS, Moscow, 2001.
  23. Khmelnik S.I. Variational Extremum Principle for Electric Lines and Planes. «Papers of Independent Authors», publ. «DNA», printed in USA, Lulu Inc., ID 124173. Russia-Israel, 2005, issue 1 (in Russian).
  24. Khmelnik S.I. Poisson Equation and Quadratic Programming. «Papers of Independent Authors», publ. «DNA», printed in USA, Lulu Inc., ID 172756. Russia-Israel, 2005, issue 2, ISBN 978-1-4116-5956-8 (in Russian).
  25. Sysun V.I. Signals and Circuits Theory. Ministry of Education of Russian Federation and American Fund of Civil Research and Development, Petrozavodsk 2003. Web-version <http://media.karelia.ru/~keip/circuit/main.htm>
  26. Khmelnik S.I. Maxwell Equations as the Variational Principle Corollary. «Papers of Independent Authors», publ. «DNA», printed in USA, Lulu Inc., ID 237433. Russia-Israel, 2006, issue 3, ISBN 978-1-4116-5085-5 (in Russian).
  27. Bredov M.M., Rumyantsev V.V., Toptygin I.N. Classic Electrodynamics, Publ. House “Lan” 2003, 400 p. , (in Russian).

28. Cherny V. The Mystery of Saturn Rings - «Nauka i Zhisn», №6, 2005, <http://nauka.relis.ru/05/0506/05506068.htm> (in Russian).
29. Khmelnik S.I. To the Question of Density Waves in Saturn Rings. "Papers of Independent Authors", publ. «DNA», printed in USA, Lulu Inc., ID 1146081. Russia-Israel, 2007, iss. 6, ISBN 978-1-4303-0843-0, (in Russian).
30. Enshin A.V., Ilidorov V.A. Longitudinal electromagnetic waves – from myth to reality. SciTecLibrary.ru, 2005, <http://www.sciteclibrary.ru/rus/catalog/pages/8036.html>
31. Khmelnik S.I. Variational Principle of Extreme in electromechanical Systems, Published by “MiC” - Mathematics in Computer Comp., printed in USA, Lulu Inc., ID 115917, Israel-Russia, 2005, (in Russian).
32. Khmelnik S.I. Variational Principle of Extremum in electromechanical Systems, second edition. Published by “MiC” - Mathematics in Computer Comp., printed in USA, printed in USA, Lulu Inc. ID 125002. Israel-Russia, 2007, ISBN 978-1-411-633445.
33. Khmelnik S.I. About Variational Principle of Extremum in electromechanical Systems. "Papers of Independent Authors", publ. «DNA», printed in USA, Lulu Inc. ID 124173, Israel-Russia, 2005, iss. 1, (in Russian), ISBN 1-4116-3209-5.
34. Khmelnik S.I. Variational Principle of Extremum in electromechanical Systems and its application, (in Russian), <http://www.sciteclibrary.ru/ris-stat/st1837.pdf>
35. Khmelnik S.I. Maximum principle and variational principle for electromechanical systems. "Papers of Independent Authors", publ. «DNA», printed in USA, Lulu Inc. 237433. Israel-Russia, 2006, iss. 3, ISBN 1-4116-5085-5, (in Russian).
36. Khmelnik S.I. Maxwell equations as the consequence of variational principle. Computational aspect. "Papers of Independent Authors", publ. «DNA», printed in USA, Lulu Inc. 322884, Israel-Russia, 2006, iss. 4, ISBN 978-1-4303-0460-9 (in Russian).
37. Khmelnik S.I. Variational Principle of Extremum in electromechanical Systems, second edition. Publisher by “MiC”, printed in USA, Lulu Inc., ID 172054. Israel-Russia, 2007, ISBN 978-1-4303-2389-1 (in Russian).
38. Erwin Madelung. Die Mathematischen hilfsmittel des physikers, Berlin, Gottingen, Heidelberg Springer-Verlag, 1957.
39. O. Heaviside, “Electromagnetic theory”, London, 1893.

40. Khmel'nik S.I., Khmel'nik M.I. To the Question of «magnetic walls» in Roschin-Godin experiments, publ. «DNA», printed in USA, Lulu Inc. 2221873, Israel-Russia, 2008, iss. 8, ISBN 978-1-4357-1642-1 (in Russian).
41. Khmel'nik S.I., Mukhin I.A., Khmel'nik M.I. Longitudinal waves of a constant magnet, publ. «DNA», printed in USA, Lulu Inc. 2221873, Israel-Russia, 2008, iss. 8, ISBN 978-1-4357-1642-1 (in Russian).
42. Khmel'nik S.I. To the problem of Saturn's rings density. "Papers of Independent Authors", publ. «DNA», printed in USA, Lulu Inc. 1146081. Israel-Russia, 2007, iss. 6, ISBN 978-1-4303-0843-0 (in Russian).
43. Khmel'nik S.I., Khmel'nik M.I. Longitudinal wave in the body of moving permanent magnet. "Papers of Independent Authors", publ. «DNA», printed in USA, Lulu Inc. 6334835. Israel-Russia, 2009, iss. 11, ISBN 978-0-557-05831-0 (in Russian).
44. Khmel'nik S.I. Longitudinal electromagnetic wave as a consequence of the integration of Maxwell equations. "Papers of Independent Authors", publ. «DNA», printed in USA, Lulu Inc. 6334835. Israel-Russia, 2009, iss. 11, ISBN 978-0-557-05831-0 (in Russian).
45. Khmel'nik S.I., Khmel'nik M.I. The existence conditions of longitudinal energy-dependent electromagnetic wave. "Papers of Independent Authors", publ. «DNA», printed in USA, Lulu Inc. 7157429. Israel-Russia, 2009, iss. 12, ISBN 978-0-557-07401-3 (in Russian).
46. Khmel'nik S.I. The structure of electromagnetic field in the vicinity of electromagnet. "Papers of Independent Authors", publ. «DNA», printed in USA, Lulu Inc. 7157429. Israel-Russia, 2009, iss. 12, ISBN 978-0-557-07401-3 (in Russian).
47. Khmel'nik S.I., Khmel'nik M.I. More about the conditions of existence of longitudinal energy-dependent electromagnetic wave. "Papers of Independent Authors", publ. «DNA», printed in USA, Lulu Inc. 7803286. Israel-Russia, 2009, iss. 13, ISBN 978-0-557-18185-8, (in Russian).
48. Petrov B.M. Electrodynamics and radio waves propagation. Moscow, publ. "Radio i sviaz", 2000. 559 p. (in Russian).
49. N.E. Kochin, I.A. Kibel, N.V. Rose. Theoretical Hydromechanics, part 2. State Publishing house. "Fizmatlit", Moscow, 1963, 727 p. (in Russian).

- 
50. Umov N.A.. The Equations of Energy Movement in a Substance - Odessa: Printing house of Ulrich and Shultz., 1874. - 56 p. (in Russian).
  51. Goldstein LD, Zernov NV Electromagnetic fields and waves. Second edition, revised and enlarged. Publ. "Soviet Radio", Moscow, 1971. - 665 p. (in Russian).
  52. Khmelnik S.I. Navier-Stokes equations. On the existence and the search method for global solutions. Second edition. Published by "MiC" - Mathematics in Computer Comp., printed in USA, Lulu Inc., ID 9976854, Israel, 2011, ISBN 978-1-4583-2400-9.
  53. Khmelnik S.I. Calculation of static electric and magnetic fields on the basis of a variational principle. "Papers of Independent Authors", publ. «DNA», printed in USA, Lulu Inc. 11744286. Israel-Russia, 2011, iss. 19, ISBN 978-1-105-15373-0 (in Russian).

# Main Notations

| Variables  | In Formulas          | In Programs  |
|--|----------------------|--------------|
| actual iterations number                                     |                      | ziklSum      |
| actual number of methodic resistance changes                 |                      | w            |
| branches array   |                      | bran         |
| branches number  |                      | VGFvetvi     |
| branches numbers in transformers table                       |                      | b1, b2, ...  |
| charges vector $q_k$ ,                                       | $q$                  | qq           |
| choice of circuit for computation                            |                      | mode         |
| circular frequency   | $\omega$             | omega        |
| complex matrix   |                      | Z            |
| currents vector $P_m$ of transformer node,                   | $P$                  | P, TokiTrans |
| currents vector $g_k$ ,                                      | $g = q'$             | qqt          |
| currents vector in methodic resistances of normal nodes,     | $X$                  | ii           |
| currents vector in methodic resistances of transformer nodes | $Y$                  | mm           |
| density of hypothetic Dirac monofields magnetic current      | $m = \text{grad}(L)$ |              |
| diagonal reciprocal capacities matrix $S_k$ ,                | $S$                  | sssDiag      |
| diagonal resistances matrix $R_k$ ,                          | $R$                  | rrrDiag      |
| electric charge density                                      | $\rho'$              |              |
| electric current density                                     | $j = \text{grad}(K)$ |              |
| electric current density                                     | $j = \text{grad}(K)$ |              |
| electric field strength                                      | $E$                  |              |
| electric potential   | $\varphi$            |              |
| electro conductivity   | $\mathcal{G}$        |              |



|  |                 |                     |
|--|-----------------|---------------------|
| EMF vector $E_k$ ,   | $E$             | EEreal              |
| EMF vector in unconditional electric circuit                                 | $\bar{E}$       | E                   |
| energian   | $\mathfrak{R}$  |                     |
| error for First Kirchhoff Law  | $\varepsilon_1$ | eK1, ErrKirh1       |
| error for Second Kirchhoff Law   | $\varepsilon_2$ | eK2, VGFerPP        |
| first and last nodes numbers of a given branch                               |                 | nBeg, nEnd          |
| full action  | $\Phi$          |                     |
| gradient   | $p$             | pp                  |
| hypothetic magnetic charge density   | $\sigma'$       |                     |
| imaginary part of transformation coefficients matrix                         | $T_2$           | tran2               |
| incidences matrix  | $N$             | N, Inzidenz         |
| incidences matrix square   | $N^T N$         | NTN, KwadraInzidenz |
| indication of currents presence in transformer nodes                         |                 | VGFyesTokiTran      |
| indication of node currents presence   |                 | VGFyesTokiUzlov     |
| indication of transformers presence  |                 | VGFyesTrans         |
| indication of transformers with complex transformation coefficients presence |                 | VGFyesTransInt      |
| inductances matrix $L_k$ and mutual inductances matrix $M_{kn}$ ,            | $M$             | mmmDiag             |
| initial methodic resistance increase coefficient                             |                 | krmin               |
| iterative process indication   |                 | res                 |
| magnetic conductivity  | $\zeta$         |                     |
| magnetic field strength  | $H$             |                     |
| magnetic permeability  | $\mu$           |                     |
| magnetic scalar potential  | $\phi$          |                     |
| methodic resistance change coefficient                                       | $k_\rho$        | stepRoo             |
| methodic resistance,   | $\rho$          | ro                  |
| minimal error for First and Second   |                 | eK1min,             |

## Main Notations

|  |                         |                    |
|--|-------------------------|--------------------|
| Kirchhoff Laws   |                         | eK2min             |
| mutual inductances matrix in unconditional electric circuit    | $\overline{M}$          | MMM                |
| node potentials vector $\varphi_m$ ,                           | $\varphi$               | ff                 |
| node currents vector $H_m$ ,                                   | $H$                     | H, TokiUzlow       |
| nodes array  |                         | nod                |
| nodes number   |                         | VGfuzly            |
| permittivity   | $\varepsilon$           |                    |
| potentials vector $\phi_m$ of transformer nodes,               | $\phi$                  | ffTran             |
| real part of transformation coefficients matrix                | $T_1$                   | tran1              |
| reciprocal capacities matrix in unconditional electric circuit | $\overline{S}$          | sssDiag            |
| resistances matrix in unconditional electric circuit           | $\overline{R}$          | RN                 |
| split energian   | $\mathfrak{R}_2$        |                    |
| split full action  | $\Phi_2$                |                    |
| tolerant iterations number                                     |                         | maxIter            |
| tolerant number of methodic resistance changes                 |                         | Wmax               |
| transformer nodes number                                       |                         | VGftpt             |
| transformers array   |                         | nodTran            |
| truncated Dirac function                                       | $\gamma'(t), \Xi(x)$    |                    |
| unit step  | $\gamma(t), \Lambda(x)$ |                    |
| $T_1T_1^T, T_1T_2^T, T_2T_1^T, T_2T_2^T$                       |                         | t11, t12, t21, t22 |
|  |                         |                    |

---

# Some of the Terms

---

| aaaTerm                                | Section |
|--|---------|
| Complex transformation coefficient     | 3.3     |
| Conjugate functional                   | 1.0     |
| Dennis transformer                     | 3.1     |
| Differentiating branch                 | 7.1     |
| Dirac function                         | 6.6     |
| Energian                               | 10      |
| Full action                            | 10      |
| Grounded electric circuit              | 7.3     |
| Instanteous values transformer         | 3.1     |
| Integrating transformer                | 3.3     |
| Interoperable function                 | 5.3     |
| Lagrange formalism                     | 10      |
| Longitudinal electromagnetic wave      | 9.7     |
| Maximization algorithm                 | 6.2     |
| Maximization method                    | 6.2     |
| Methodic resistance                    | 3.2     |
| Outside variable                       | 6.1     |
| Power density                          | 10      |
| Principle extremum of full action      | 10      |
| Quasiextremal                          | 10      |
| Quasivariation                         | 4.1     |
| Secondary functional                   | 4.1     |
| Split energian                         | 10      |
| Split full action                      | 10      |
| Splitting functions                    | 10      |
| Step function, unit step               | 6.2     |
| Transformers matrix                    | 3.1     |
| Unconditional electric circuit         | 3.2     |
| Volatile standing electromagnetic wave | 9.7     |
|  |         |