

“What’s (the) Matter?”,

A Show on Elementary Particle Physics with 28

Demonstration Experiments

Herbi K. Dreiner^{*1,2}, Max Becker³, Mikolaj Borzyszkowski⁴, Maxim Braun¹, Alexander Faßbender¹, Julia Hampel¹, Maike Hansen¹, Dustin Hebecker^{1,5}, Timo Heepenstrick⁶, Sascha Heinz¹, Katharina Hortmanns¹, Christian Jost³, Michael Kortmann¹, Matthias U. Kruckow⁴, Till Leuteritz¹, Claudia Lütz³, Philip Mahlberg³, Johannes Müllers³, Toby Opferkuch^{1,2}, Ewald Paul¹, Peter Pauli³, Merlin Rossbach³, Steffen Schaepe¹, Tobias Schiffer¹, Jan F. Schmidt¹, Jana Schüller-Ruhl⁴, Christoph Schürmann¹, Lorenzo Ubaldi^{1,7}, and Sebastian Wagner-Carena⁸

¹Physikalisches Institut, Universität Bonn, Nussallee 12, 53115 Bonn, Germany

²Bethe Center for Theoretical Physics, Universität Bonn, Nussallee 12, 53115 Bonn, Germany

³HISKP, Nussallee 14-16, 53115 Bonn, Germany

⁴AIfA, Auf dem Hügel 71, 53121 Bonn, Germany

⁵Humboldt-Universität zu Berlin, Institut für Physik, Newtonstrasse 15, 12489 Berlin, Germany

⁶Physikalische Chemie, Wegeler Strasse, 53115, Bonn, Germany

⁷Raymond and Beverly Sackler School of Physics and Astronomy, Tel-Aviv University, Tel-Aviv 69978, Israel

⁸Jefferson Physical Laboratory, Harvard University, Cambridge, MA 02138, USA

Abstract

We present the screenplay of a physics show on elementary particle physics which has been developed by the Physikshow of Bonn University. The show is addressed at non-physicists aged 14 to 99 and is intended to communicate some basic concepts of elementary particle physics including the discovery of the Higgs boson in an entertaining fashion. It is also intended to demonstrate a successful outreach activity which heavily relies on the university physics students. This paper is addressed at anybody interested in particle physics, hopefully the combination of the screenplay and the detailed descriptions of the experiments will be illuminating. This paper is also addressed at fellow physicists working in outreach, maybe the experiments and our choice of simple explanation will be helpful. Furthermore, we are very interested in related activities elsewhere, in particular also demonstration experiments relevant to particle physics, since as far as we are aware, little of this work is published.

*For electronic correspondence please contact H. K. Dreiner at dreiner@uni-bonn.de.

Our show involves 28 live demonstration experiments. These are presented in an extensive appendix, including photos and technical details. The show is set up as a quest, where two students from Bonn with the aid of a caretaker travel back in time to understand the fundamental nature of matter. They visit Rutherford and Geiger in Manchester around 1911, who recount their famous experiment on the nucleus and show how particle detectors work. Then they travel forward in time to meet E. Lawrence at Berkeley around 1950, teaching them about the how and why of accelerators. Next, they visit Sau Lan Wu at DESY, Hamburg, around 1980, who explains the strong force. The final stop is in the LHC tunnel at CERN, Geneva, Switzerland in 2012. Two experimentalists tell them about colliders and our heroes watch live as the Higgs boson is produced and decays. The show has been presented in English at Oxford University and University College London (3/2014), as well as Padua University and ICTP Trieste (3/2015). It was first performed in German at the Deutsche Museum, Bonn (5/2014). The show has eleven speaking parts and involves in total 20 people.

Contents

1	Introduction	3
2	Precursors to our Show and Related Activities	5
3	Logistics	8
3.1	Equipment	9
3.2	People	10
3.3	Rehearsals	10
3.4	Music	11
3.5	Costs	11
3.6	Audience	11
4	The Play	12
4.1	Prologue: Bonn, Germany	12
4.2	Manchester, UK	15
4.3	Berkeley, California	21
4.4	DESY, Hamburg, Germany	30
4.5	CERN, Geneva, Switzerland	38
5	Conclusion	49
A	Technical Details of Demonstration Experiments in the Show	51
A.1	Presentation technique	51
A.2	Fire Tornado	53
A.3	Lord Rayleigh’s Oil Drop Experiment	55
A.4	Wooden Scattering Experiment	57
A.5	Cathode Ray and Helmholtz Coils Experiment	59
A.6	A Simple Charged Particle Detector: Radioactive Decay and Jacob’s Ladder	62
A.7	Cloud Chamber	66
A.8	Beta−, and Beta+ Decay, Antimatter Live Onstage	68
A.9	Ripple Tank: Resolving an Object with Water Waves	70
A.10	Dancing Paper Men and the Electric Field	73

A.11 Linear Accelerator	74
A.12 Salad Bowl Circular Accelerator	75
A.13 Mechanical Synchrotron	78
A.14 Flour Explosion	80
A.15 Vacuum Cannon	82
A.16 Testicle Model	86
A.17 Balloon Tossing	87
A.18 Air Table and Strong Force	88
A.19 Photon Clicker	89
A.20 Tossing Medicine Balls on Inline Skates	92
A.21 Relativistic Bicycle	94
A.22 Tesla Coil	96
A.23 Tossing Balls: a Collider Onstage	100
A.24 Visualizing the Electric Vector Field	101
A.25 Scalar Field: Analogy	103
A.26 Visualizing the Scalar Higgs Field	103
A.27 The Higgs Mechanism and Eddy Currents: an Analogy	104
A.28 Light-Suits and Higgs Collision	106

1 Introduction

With the rise of contemporary science it has become more pertinent to find a means of communicating groundbreaking and essential scientific results to the general public. Galileo Galilei, arguably the founder of modern science, took a bold step in 1630 when he published his *Dialogo* [1] in Italian, over the traditional Latin, making his thoughts and results accessible to a much broader audience. When the Royal Institution [2] was founded in London in March 1799 “with the aim of introducing new technologies and teaching science to the general public” the bridge between the academic and public domain strengthened. One of its early presidents, Michael Faraday, was a strong proponent of presenting physics to the public, including the use of live experiments. During his tenure, he created the famous Christmas lectures, an annual series of entertaining lectures on a single scientific topic which the museum still holds to this day. For example, on May 27th, 2014, at the Royal Institution, one of us (H.K.D.) was able to attend Jon Butterworth’s lecture launching his popular book “Smashing Physics” on the LHC and the Higgs boson [3], where he also showed two live experiments. In Germany the Deutsches Museum of Masterpieces in Science and Technology [4] was founded in 1925 with the intention of displaying major scientific results through engaging demonstrations. Today it boasts hundreds of unique and interactive exhibits that help “[bridge] the gap between research and education.” We have visited the Deutsches Museum München three times with the Bonn physics show with various programs, and have also performed five times in the branch of the Museum, in Bonn, Bad Godesberg. The Deutsches Museum technique quickly caught on and inspired several similar museums, for example the Science Museum, London [5] and the Museum of Science and Industry in the city of Chicago [6]. A museum founded by a former particle physicist, Frank Oppenheimer in 1969, and famous for its hands-on experiments is the Exploratorium in San Francisco [7].

The Bonn physics show was launched in Dec. 2001 as an opportunity for the Bonn University physics students to be creative in developing new forms of presenting physics

to a broad audience, in particular for school kids aged 10 to 18. From the beginning the shows typically filled with demonstrations in the context of classical physics, were sometimes in the form of actual plays and always filled with music and jokes, very different from a traditional lecture.

With the launch of the LHC in September 2008, and the discovery of the Higgs boson in 2012 [8, 9], there has been a renewed public interest in elementary particle physics with a focus on the Higgs boson. In response there has been a wide range of books written for a broader public [3, 10, 11, 12] and numerous public lectures. In contrast, the principle behind our show “What’s (the) Matter?”, which we present here, is to use our extensive experience in physics shows as well as the rich tradition of engaging the public in physics through *live* shows with many *live* demonstration experiments to the latest developments in *modern* physics and in particular the recent discovery of the Higgs boson. The challenge was clearly to find experiments which are relevant, understandable, exciting *and* can be performed live. We show as many direct particle effects as possible, for example using radioactive probes, but naturally often revert to analogies.

To this effect we have developed a show based on a simple story line. A previous show was devised more as a lecture (see the description in Sect. 2). But we have found through our other shows which mainly involve classical physics (not the subject of this paper), that a story line better holds the attention of the audience.

The show is set up as a quest, where two proponents from Bonn travel back in time to understand what is matter. They first visit Ernest Rutherford and his assistant Hans Geiger in Manchester around 1911. He tells them about the atomic nucleus, radioactivity and how to detect it, as well as the idea behind scattering experiments. They then travel forward in time to Ernest Lawrence at the University of California, Berkeley, around 1950, where they learn about the how and why of accelerators. On the next stop they visit Sau Lan Wu at the PETRA accelerator at DESY, Hamburg, around 1980, who explains quantized gauge interactions and the strong force. The final stop is in the LHC tunnel at CERN, Geneva, Switzerland in 2012. Two experimentalists explain colliders and our heroes watch live as the Higgs boson is produced and decays.

For us it has always been important to connect physics concepts with live physics experiments. Thus the play includes 27 experiments, which we perform live onstage, with the obvious risk that some demonstrations might not work. However this is actually the heart of our show, and we have thus included an extensive discussion of all the experiments involved.

The purpose of this paper is to present our current show in detail, such that it might benefit other people presenting particle physics to the public. Since very little of outreach activity is published, we strongly encourage other groups to contact us, to let us know what they are working on, so that we can exchange ideas and demonstration experiments.

The outline of this paper is as follows. In the next section we describe our own previous shows, which have led up to this production. We also give highlights of the history of other related activities, as far as we are aware of. In Sect. 3, we discuss the logistics required to perform this show, and in particular also to take it on the road. Sect. 4 contains the screenplay of the show, as performed in Padua, Italy, March 2015. The experiments are explained as given by the script of the play. In Sect. 5 we conclude. In App. A, we describe the experiments in detail, including the technical specifications on how to build and also how we find it best to perform them. This might be the most useful section for many readers.



Figure 1: Group photo at the Weltmaschine exhibition in the subway station Bundestag in Berlin in front of an oversize photo of the ATLAS detector, Nov. 16th, 2008. Photo by Christian Mrotzek.

2 Precursors to our Show and Related Activities

Physics experiments have been demonstrated publicly for a very long time. In Germany, for example, Otto von Guericke, the mayor of Magdeburg, demonstrated his vacuum pump and the Magdeburg hemispheres¹ at the Reichstag in Regensburg in 1654 and several times to the general public afterwards [13]. In Europe and the USA there were public demonstrations of electrical effects in upper class salons and at fairs in the 18th century [14]. As mentioned in Sect. 1, in Great Britain, Faraday regularly gave public physics lectures including demonstrations in the early 19th century. Unfortunately, it is beyond the scope of this paper to give a comprehensive overview of the history of public science demonstrations. We thus focus on our own history and related present day activities.

Around 1970 Prof. Bassam Z. Shakhshiri started a program of public chemistry lectures and shows [15] entitled ‘Science is Fun – in the Lab of Shakhshiri’ in the chemistry department at the University of Wisconsin, Madison [16]. In 1984, this inspired Prof. Clinton Sprott in the physics department at the University of Wisconsin to start a physics show entitled ‘The Wonders of Physics’ [17, 18]. For recent activity see their webpage [19]. One of us (HKD) attended the University of Wisconsin, Madison (1984-1989). The Bonn Physikshow was started in Dec. 2001 by two of us (HKD, MKo), with a first show in Nov. 2002 [20, 21, 22, 23, 24]. A distinguishing feature of the Bonn Physikshow is that the students develop and present the shows largely on their own. We (MKo, SH, HKD) offer technical assistance. The guidance is mainly provided by more

¹He also invented the vacuum cannon, which we employ in the play, and discuss in App. A.15.

senior students. In addition, we have developed a new show almost every year since 2002, giving each class of new physics students the opportunity to develop their own show. Between 15 and 25 students participate each year. It takes roughly 6 months to develop a new show. During the show itself we originally had two people moderating the show and explaining the experiments, with the others performing them. Starting in 2004 we began incorporating simple storylines into the show, and in the process giving more people speaking parts. The storyline often puts experiments we had used in previous shows in a completely different context; it also helps to hold the attention particularly of the younger audience members, and can highlight the extraordinary features of even very simple experiments. The storyline has become a central feature of all of our shows and something we highly recommend. We would be particularly interested in hearing of related activity elsewhere employing storylines or similar. However we should mention, that we are not professional actors or stage crew. Instead we are physicists and physics technicians. The emphasis is always on the experiments and the correct presentation of the physics, although we do enjoy a good joke!

In Bonn, the show initially focussed on classical physics with typical experiments for example in mechanics, electromagnetism, and acoustics. We also employed high T_c superconductors and occasionally radioactivity, *e.g.* uranium glass. In 2004, CERN turned 50 years old and to celebrate we created for the first time a show on particle physics. It was developed together with Prof. Michael Kobel (now TU Dresden) and Dr. R. Meyer-Fennekohl, as well as several Ph.D. students and postdocs in particle physics at Bonn University. Since then EP has been a full member of the team. This show was devised more as a lecture with many demonstration experiments, including the experiments discussed in A.3, A.5, A.6, A.7, A.13, A.15, A.18, an extended version of A.20, and A.22, as well as a water Čerenkov experiment in a thermos (Kamioskanne) [25]. The show was entitled ‘From Quarks to Quasars’ and included the topics ‘Atoms and Nuclei’, ‘Particles and Forces’, ‘Symmetries’ and ‘Astrophysics and Cosmology’. There was no storyline.

In the Autumn of 2008, with the initial launch of the LHC, the German funding agency (ministry) for large experiments (Großgeräteforschung), BMBF (Bundesministerium für Bildung und Forschung), organized an exhibition on the LHC [26]. This involved active research particle physicists as tour guides and was located in a new subway station in the center of Berlin: ‘Bundestag’, see Fig. 1. The exhibition had the somewhat grandiose title ‘Weltmaschine’ (World Machine). In Nov. 2008, we were invited to perform a 90 min particle physics show in Berlin, at the exhibition. We modified the 2004 show, including a new presentation modus, with always just one or 2 experiments on stage, due to the limited space. Experiments were rapidly exchanged through wheeled carts and many stage hands. As a guiding point, we had a bookshelf on wheels, where a clown added boxes labelled by the particle symbols as the particles were introduced in the show, see the background in Fig. 2. A highlight was the vacuum cannon, see Figs. 2, 3, as well as App. A.15. This show was very successful and we were invited to repeat it in the Ehrensaal of the Deutsches Museum, München (March, 2009), at the German national particle physics laboratory DESY, Hamburg (Sept. 2009), and at the University of Heidelberg (Dec. 2009). In September 2010, we performed the show in French in the Globe at CERN, Geneva, Switzerland. This was our first trip abroad.

In 2012, in the framework of the DFG (Deutsche Forschungsgemeinschaft, a national German funding agency, similar to NSF in the USA) research grant CRC 110 ‘Symmetries and the Emergence of Structure in QCD’ [27], the Bonn Physikshow was awarded a large grant to produce a new particle physics show and to travel with this show. The

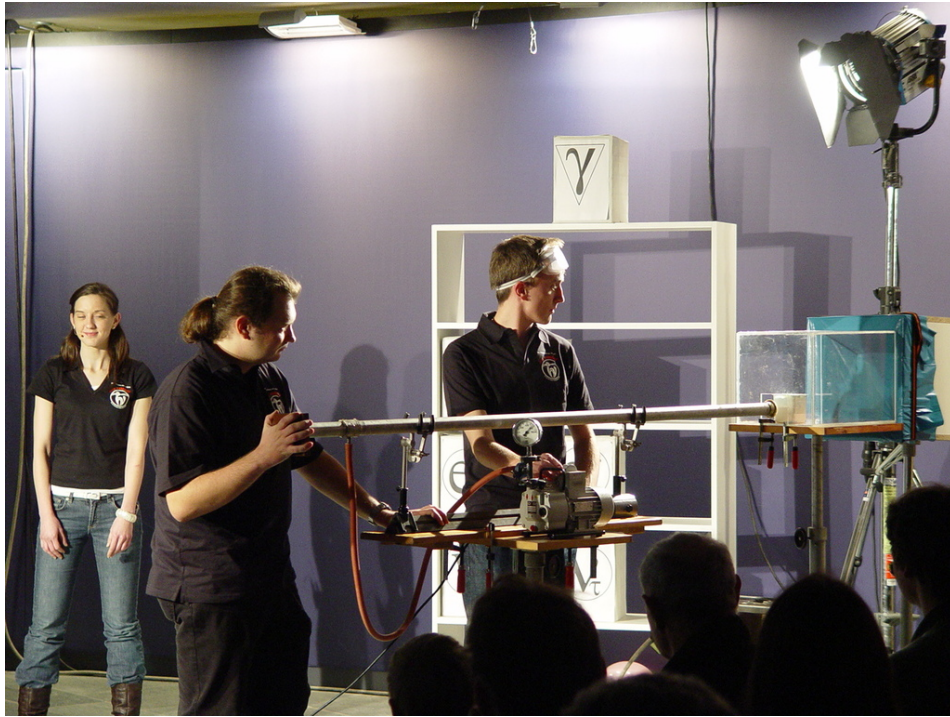

Figure 2: Vacuum cannon, the experiment described in A.15, onstage in Berlin, with Cornelia Monzel, SSch and Nicki Bornhauser (from left to right). Inside the clear plastic box is the quark target. For a detailed view see Fig. 3. Behind, the white box covered by the blue plastic bag is the beam dump, with toilet paper rolls inside. In the background is the particle shelf.



Figure 3: Collision event of the vacuum cannon as displayed in our plastic detector. The wooden projectile can be seen on the lower right.

result of this is presented in this paper. As can be seen, we developed a completely new

show now based on a storyline, and with many new experiments. The show was written in English and first performed in the Martin Wood Lecture Theatre at the physics department of Oxford University.

We recently became aware of a very nice show entitled ‘Accelerate’ performed in Oxford in Dec. 2011, before the discovery of the Higgs boson. A full length video of the show can be seen at [28]. An extensive write-up of ten experiments is given at [29]. Compared to our show, their show is more like a lecture, *i.e.* there is no story line. It has a female and male moderator, who regularly involve the audience, in the film these are school children. It focuses on how accelerators like the LHC work and illustrate the science involved. To illustrate electrostatic charges they use a van der Graaf. They demonstrate wake-field acceleration with beach balls together with the audience. They also use the cathode ray tube, App. A.5 and a smaller version of the cloud chamber App. A.7.

3 Logistics



Figure 4: Group photo in the Martin Wood lecture theatre in the Physics department of Oxford University. Back row left to right MR, CJ, JSchm, JH, DH, CL, JSch-R, MH, LU. Front row left to right MBe, PM, TH, SH, JM, MKr, TSch, and MBo. Lying in front EP (left) and HKD (right).

The show we describe here was developed for a first set of four performances in the Martin Wood Lecture Theatre in the University of Oxford Department of Physics, in March 2014, see also Fig. 4. It was immediately followed up by two shows in the Cruciform Lecture Theatre at University College London. Thus from the beginning it was clear that we would be traveling with the show. A significant effort is involved in transporting all of the required equipment, as well as the about 20 people. Here we give a few details which might be helpful, if somebody wishes to organize and perform something similar.

In the past we have travelled extensively with the physics show, starting in 2005 to the Deutsches Museum, Bonn, Bad Godesberg. We have returned: 2013, 2014 and 2015 (2x). Further trips have included the Deutsches Museum of Masterpieces in Science and

Technology in München (2006, 2009, 2013, 2017 planned), Berlin (2008), Göttingen University (2008), Wallraff-Richartz-Museum Köln (2009), DESY (2009, 2014), Heidelberg University (2009), CERN (2010), Sternwarte Solingen (2010), BayKomm Leverkusen, the outreach division of the company Bayer (2012, 2015), the LVR Museum Oberhausen (2015), the LVR Museum Solingen (2016), and the Physikzentrum Bad Honnef (2016). With the show presented here, we have also travelled to Padua and Trieste, Italy (March 2015) and plan to travel to Copenhagen and Odense (August, 2016). In March 2016 we travelled with 9 people to Beijing, China, and for a week taught 15 physics students at Peiking University and Chinese academy of Science, Institute of Theoretical Physics (CAS, ITP) how to perform a physics show using their local equipment, culminating in a show in Chinese for local highschool students. We have thus gained a significant amount of experience with many logistical aspects.

3.1 Equipment

We have a collection of 28 demonstration experiments for this show, which we perform live onstage. Some are quite large, as described in the appendix, App. A. For example the fire tornado is 2 m tall and 0.63 m in diameter, see App. A.2. For all of these experiments, we bring everything that is needed to run them, including the power cords and other required cables. If we are abroad, we bring a large number of adapters, as unfortunately the sockets in Europe (especially in Britain) are not universal.

Depending on the location, we set up a control table either upfront, on the side of the stage or at the back of the lecture hall. This table has two laptops as well as a 6-channel mixer. During the show, from this table, two students control the projection, the lighting, as well as play the music and sound effects. We run all control cables for the lighting and cameras (which we all bring) to this one table. We have to-date always made use of the local sound system, which we hook-up to our control instruments at the table. We usually make use of the local microphones, although we also bring some of our own, as we need headsets for all people who both perform experiments onstage, as well as speak.

In addition to the physics experiments we have two 1000 W halogen lamps (Hedler, type H25s). They are controlled via a dimmer pack (Elation Unipak II) using a DMX (digital multiplex) interface. We furthermore use two LED lights with 36 x 3 W each (Eurolite LED Theatre 36 x 3 W CW/WW). We also used one 1000 W spotlight (Moonlight 1000, Model MN1000, GX9,5 220/240V/1000W). The flood lights are essential to get a proper stage lighting, which is usually not available in physics lecture halls. The spot light is important for various parts of the story, where we darken the stage and just light up one small part, *e.g.* the person dressed as a Blues Brother on the balcony in Padua, or the Caretaker at the end of the show. We also have two cameras which we use to project smaller experiments onto the screen.

We employ an overhead projector for the Rayleigh oil drop experiment, see App. A.3.

To-date we have always brought our own radioactive materials. We must transport these in a special metal box, complying with the latest European Union transport rules. We furthermore bring various materials needed for the experiments, such as the Quark for the vacuum cannon App. A.15, or the plastic balls discussed in App. A.23. Several of the actors wear costumes, which we also bring along. For most shows we have developed new Physikshow T-shirts.²

²We thank Karina Kortmann for designing several shirts.

In total, with all the experiments, this fills two vans. We use VW Transporters provided by Bonn University, each corresponding to a maximum load volume of about 6 m^3 , which we make almost complete use of. The maximum added weight load is 900kg. We drive the vans ourselves.

3.2 People

In the physics show ‘*What’s (the) Matter?*’ two students (MH and LU) lead through the show. They are accompanied by a caretaker (JSchm), who also runs the time machine. In each “time zone” they meet two scientists, who explain new physics. Altogether there are thus eleven speaking parts. In principle it would be possible to have the actors of the first two sections (Manchester, Berkeley) doubling up for the second two sections (DESY, CERN), reducing the number of speaking rôles to seven. However, typically we are not experienced actors and one rôle per person is enough. In addition, outside of their part, the actors help on lighting (spot) and stage management, taking experiments on- and offstage.

As mentioned above, we have two people at the technical table for sound, lighting, projection and music. The spot is handled in turn by someone not involved onstage.

We must move a significant amount of equipment on- and offstage, during the show, to avoid cluttering the stage. (In Oxford the stage was also fairly small.) In order for this to proceed smoothly, we have two stage managers to organize the sorting, setup and dismantling of all the experiments, before, during and after the show. These are important full-time jobs, which ensure the show runs smoothly. Between parts two (Berkeley) and three (DESY) we exchange most of the experiments onstage. This requires a short break.

We have one person who is responsible for the radioactive materials, full-time. This has mainly been EP, and should be a senior experienced scientist or technician. This requires formal safety training with radioactive materials.

Almost all experiments are projected via cameras onto a screen, which is best well above the stage. This enables everybody to see important details of the experiments. For this we have two people full-time on the cameras onstage. The camera positions must also be rehearsed, as well as where the actors stand with respect to the experiment and camera. The oil drop experiment A.3, is projected onto a possibly separate screen. The water wave experiment A.9 is projected directly onto a wall.

In Oxford and London we had one technician, SH, which is the absolute minimum. In Padua and Trieste MKo also joined, and doubled as a camera man. We thus had two very experienced people who could help out at any moment, if any experiment failed or there were problems with the lighting, the sound or the projection. This was very helpful, as something always goes wrong³.

Thus we need at least 19 people for this show, with experienced actors 15 should suffice. In Oxford we were 19, in Padua 20. See Fig. 4 for the Oxford group photo.

3.3 Rehearsals

Since it is essentially a play we are performing, we require significant rehearsal time in Bonn. For a new show at least 8 days all day. The students taking part are not

³In Trieste the vacuum cannon failed, because the end piece wasn’t greased properly. SH was able to fix this in real time and by the time the cannon reappeared in the CERN section it was ready for use. Thus, although not foreseen, we instead performed the experiment properly in the last section.

always the same as they have many other commitments. Thus we also needed a week of rehearsals before our trip to Padua. Furthermore each lecture hall is different. We try to learn as much about the local stage beforehand as possible, sometimes marking the stage size by for the rehearsals in Bonn. In order to get all the equipment hooked up properly we often have to place experiments differently on different stages. We thus need at least one full day in a new location to set up all the experiments and technical equipment and rehearse who is standing where, who brings in what experiment between the acts *etc.* On a two-stop trip such as the UK (Oxford, London) and Italy (Padua, Trieste) the team is well organized by the second stop and we need much less local rehearsal time.

3.4 Music

We make extensive use of music during our shows, which we play from a laptop. In Germany we therefore pay *GEMA* fees for all shows. For comedic purposes, we also make use of sound effects, *e.g.* a plop sound when the oil drop is applied in the Lord Rayleigh experiment, see App. A.3.

3.5 Costs

3.5.1 Lodging and Board:

The main costs of the show are board and lodging for typically 19 or 20 people for several days. We have travelled for one-place-only to München and Hamburg. Allowing for the one full day of local rehearsal and then three to four shows spread over two days, we need at least three overnights. This corresponds to sixty overnights. For two-stop-trips the team is well in-sync by the second stop and things proceed faster. We stayed in Oxford for four nights, but only two nights in London. We stayed four nights in Padua and also only two nights in Trieste.

3.5.2 Transport:

The trip Bonn–Padua–Trieste–Bonn is 2,252 km, according to Google maps. With two vans and a cost of €0.43/km, this corresponds to about €1,936.72. Our university also has a 17-seater bus, which costs €0.63/km plus expenses for the driver (hotel and per diem). This is another €1,418.76 (plus hotel and per diem).

3.6 Audience

When we started our physics shows in 2002, we devised the (general) show for children aged 10 or 11 years and older. There was an article in the local newspaper beforehand, announcing the show, and about 750 people of all age groups showed up, packing our 550 seat auditorium. (We have since introduced a booking system.) It turned out that also children as young as 5 years already very much enjoyed the shows. Now we typically perform twice on the weekend for a general audience and have an extra show on a Friday morning for school classes. For the latter we specifically advertise the show for students in 4th grade through 7th grade, *i.e.* for ages 9 through 12.

The particle physics show as presented here we advertise for teenagers aged 15 and older. However also here we have found that there is enough action in the show that



Figure 5: Fire tornado onstage at Trieste. The cage is about 2 m high. On the right is MKr.

younger kids take great pleasure in attending. They might not understand all explanations, but will still hopefully get an appreciation of the physics at the LHC.

In all cases grown-ups are also very welcome. However, our impression is that adults with little or no background in physics feel more welcome to a show which is advertised for kids 10 years and older, than 15 years and older. In the latter case they often suspect that advanced secondary school physics might be a prerequisite and they don't come.

4 The Play

The following is the screenplay as performed in Padua, March 2015. The show was just under 2 hours long, including an about eight minute intermission after the Berkeley part, required for resetting the stage with the new experiments.

4.1 Prologue: Bonn, Germany

(Dark stage.)

Exp: Fire tornado (see Fig. 5 and App. A.2).

(Two students on towels, in a spotlight, hanging out on the beach along the river Rhine in Bonn, Germany. Behind them the fire tornado, Fig. 5. Contemplative silence. Passing a large bag of HARIBO back and forth. Lorenzo occasionally tosses gummi bears out, see Fig. 6. To the side a caretaker is sweeping. Next to him is a 'Lost & Found' box.)

Maike: *(Gazing up at the stars)* Lorenzo?

Lorenzo: *(Absent minded, eating HARIBO)* Huh?

Maike: Did you ever wonder where it all came from?

Lorenzo: Maike, do you mean HARIBO? I'm pretty sure it's from Bonn.



Figure 6: Maike (MH) and Lorenzo (LU) contemplating the universe and the yellow gummi bears.

Maike: Really?

Lorenzo: Yeah, sure. Founded in Bonn in 1920 by **HA**ns..**RI**egel..**BO**nn. HA – RI – BO.

Maike: Anyway, no, I mean ... everything ... you know: the stars, the planets ...

Lorenzo: Oh, that's what you mean, how the universe began, how it will end. Or simply: what is "matter"? ... Paah, beats me. *(Continues eating gummy bears.)*

Maike: Yes, exactly. *(Holds up a stone.)* Where does this rock come from? And what is it exactly that it is made of? Where does MASS come from?

Lorenzo: I know that my mass mainly comes from Haribo. I definitely eat too much. But it seems impossible to stop. Sometimes I eat so much, I start sweating. Now, if I just smell them, I can feel the perspiration coming.

Maike: Argh! Too much detail. How about this: where does the mass of the HARIBO bears come from? I mean they don't eat other gummy bears, do they?

Lorenzo: Aha! Another yellow one! I have always wondered why there are so many yellow gummy bears. I don't like the yellow ones. Don't they remind you of coagulated wee?

Maike: Lorenzo! Come on, didn't you also hear about the LHC and the Higgs boson. It's supposed to be really important. What do you think? ... Or do you think?

Lorenzo: (*sighs*) Okay, okay, you are like a dog with a bone! Just a second, let me think. (*Poses in deep thought, briefly.*) Ok, I give up. I have no idea. If you really want to know ... why don't you ask the caretaker over there? (*Points to a strange figure to the side who has a large broom and is sweeping.*)

Maike: Huh? What is he doing here? And why is he sweeping here in the park, by the Rhine?

Lorenzo: I don't know, I just saw him ... well go ahead, you might as well ask.

Maike: Okay: Excuse me, Mr. ..., (*Holds up a rock.*) What is matter? What is it made of? And most of all: where does mass come from?

Caretaker: Oh, hello Maike. Hello Lorenzo. Nice to meet you. (*Turning towards the audience,*) I've always wondered when this will happen. (*Back to Maike and Lorenzo*) Okay, here is your answer: mass comes from red gummy bears!

Lorenzo: What???

Caretaker: Worried Lorenzo? Haha, just kidding. Anyway, these are very big questions. You are shooting for the moon, so to speak ... excuse the pun. You must go on a personal journey, a long and arduous quest, during which you Lorenzo must grow, so that both of you can fully understand the answers you will find. Are you prepared? Your travels will take you through space AND time

Maike: Oh, he's just kidding again...

Caretaker: No, no, no! You must get ready. Grab your towels, your gummy bears and, most important, take an umbrella.

Lorenzo: An umbrella?

Caretaker: Wait a moment! (*Rummages around in his lost and found box, chooses finally an umbrella.*) Ah, there it is! This one has been in here for a long, long time. Spin the umbrella and off you go.

(*Maike and Lorenzo hold the umbrella above their heads and open it*)

Caretaker: No, that is the British way. You must hold it forward. (*Towards the spotlight which is shining from the back of the auditorium.*)

Maike: Will we see the LHC? Or even the Higgs boson?

Lorenzo: Will I lose any weight?

Caretaker: You must start at the beginning. ... Maybe then you can see the answers yourself...
(*Time travel starts, see Fig. 7, accompanied by music and a film.*)



Figure 7: Maike (MH) and Lorenzo (LU) partially hidden behind the rotating umbrella, which represents the time machine.

4.2 Manchester, UK

Maike: Wow! That was some journey. Lorenzo, are you ok? (*Lorenzo nods.*) Where are we here? (*Lifts an old object.*) And also ... when?

(*Caretaker directs Maike and Lorenzo into new space highlighted by spot. In the dark, Rutherford and Geiger are frozen at their lab tables.*)

Caretaker: Welcome to Manchester ... the best football town ... in England. (*Looks at his watch.*) It is 1911. This is Ernest Rutherford and his German assistant Hans Geiger. They should be able to help you with your questions. Have a good time! (*The Caretaker claps his hands twice, Rutherford and Geiger come to life.*)
(*Caretaker starts cleaning blackboard/screen for oil drop experiment.*)

Rutherford: Welcome to my laboratory here in Manchester. What can I do for you?

Maike: We are on a journey through space and time and would like to know (*Holds up the rock.*) what matter is made of. And, why do objects have mass?

Rutherford: You have come to the right place! (*Pause, looks up, throws out his chest.*) Let me make a bold statement: everything, all matter, is made of small bits, which we call atoms.

Maike: You mean, like small Lego blocks. (*Holds up some Lego blocks.*)

Rutherford: Yes that is a good analogy.

Lorenzo: How big are these building blocks? (*Holds up his Haribo bag.*) And what are their colours?

Rutherford: For that, let ME show you an experiment, which my assistant will conduct over here. This is *Herr Geiger* from Germany.

Geiger: (*Clicks his heels.*) *Guten Tag.*

Maike,Lorenzo: *Guten Tag.*

Geiger: Let me show you an experiment that demonstrates how ridiculously small these smallest particles, the atoms, actually are.

Exp: Oil drop experiment (see App. A.3)

Caretaker stops cleaning the screen, when the projector is switched on and continues with other furniture/blackboard/...

Rutherford: We have here a small dish filled with water. It is placed on an overhead projector so that you can see it on the screen. Herr Geiger will add some fine spores. They are floating on the water — you can see them as small black dots.

Then he puts a drop of oil on the surface.

(*Geiger let's oil drop on surface, "PLOP"-sound comes over loudspeakers.*)

It pushes away the spores. At the end, the layer of oil has a thickness of one oil molecule only. Beforehand, we can measure the volume of the oil drop and the area of the surface covered by the oil drop. With these numbers we can calculate the size of an oil molecule using the formula shown on the slide.

(*Formula projected with beamer.*)

Here you see the drop volume. We then divide by the area of the oil drop, as measured in our experiment. The calculation yields that the size of an oil molecule is equal to one part in ten billionth of a meter, or written in a mathematical way: 10^{-10} meters. (*This number is also on the slide.*)

Maike: Wow, so they are really, really small!

Lorenzo: (*Thinking ... counts on his fingers.*) That means that even this super sharp knife (*Shows a sharp kitchen knife.*) here, at the smallest part of the blade, is about 1 million atoms wide? That is amazing!

Rutherford: Yes, that is about right. Very good. And moreover, most atoms are very stable and always the same. They are composed of even smaller particles.

Lorenzo: How can these smaller bits come together to always make identical atoms??

Rutherford: You have come to the right man. In fact, I, Ernest Rutherford from New Zealand(!), am the world expert on the substructure of the atom.

Lorenzo: Oohh, really?

Rutherford: Yes, I am from New Zealand.

Lorenzo: No, I meant about the atom.

Rutherford: Ah yes, sorry, ... (*swells chest*) indeed, I was the first person, to look deep inside the atom. ... Well my assistants helped me... (*shrinking*)

Lorenzo: Aaah!

Rutherford: Well they actually did all the dirty work... (*shrinking further*) ... Endless waiting for little light blips. That was a task for Geiger – he is good at counting!

Lorenzo: So was it Geiger who actually did all the work??

Rutherford: Ehm, ok, no matter. Come over here and have a look with us. We have prepared a further experiment.

Exp: Scattering experiment (see App. A.4, and Fig. 8.)

Geiger: Let me show you how to look into the small world of the atom. Commonly this is done with scattering experiments. That means you scatter projectiles, particles, off of an arbitrary target and then learn something about it... This setup demonstrates how scattering experiments are done.

Lets have a look at the screen over there. We have some steel balls which we use as projectiles. (*Shows one steel ball to the audience.*) After rolling down this ramp, they hit the target placed in the center and get deflected. The scattered projectiles are collected in these pockets along the side.

(*3 particle bunches on circular target.*)

Lorenzo, what do you think?

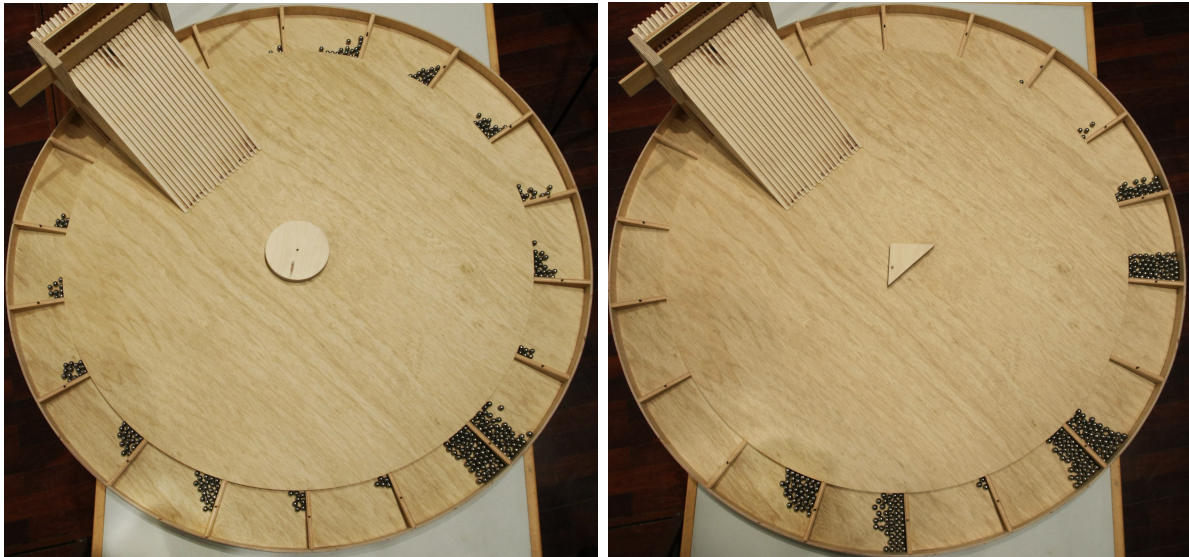

Figure 8: Result of scattering multiple bunches on the left off of a circular target, and on the right off of a triangular target. On the left, except for the forward direction, the projectiles are roughly evenly distributed. On the right with the triangular target, the projectiles accumulate in two bins on either side, respectively.

Lorenzo: Apart from the very forward direction, it looks like the projectiles are more or less uniformly distributed.

Geiger: Very good, well observed. The many particles in the forward direction did not hit our target in the center, passed it on the left or right and thus went straight through. The other particles hit the circle and were deflected almost uniformly.

(Caretaker collects the previous steel balls with a magnet, puts them in his overcoat pocket and exits stage.)

And now I replace the circular target with a triangular one. Spot the difference. . .

(3 particle bunches on triangular target.)

Maïke: Ohh, that looks quite different. The scattering pattern has changed. . . The projectiles are no longer distributed uniformly, but now seem to show three populated spots.

(Maïke points at the three spots.)

Geiger: Exactly! We again have one accumulation where the particles missed our target straight ahead. . . Here and here we observe a higher density, where the particles hit the flat side of the triangle and are deflected to these pockets. . . We have repeated the experiment with both targets many times and taken some photos.

(Show comparison photographs on the screen. Seen here in Fig. 8.)

So that is the general concept of a scattering experiment. You shoot a bunch of particles at an unknown target and you learn something about its structure from the way the particles are scattered. This works even if the target is so small that you can not see it with the naked eye.

Rutherford: Fine... fine... (*Film starts. Rutherford explains the film.*)

Exp: Rutherford scattering – film

In my original experiment I used an apparatus like it is presented to you on the screen. Alpha particles emitted from a radioactive Radium source were used as projectiles. The thin gold foil, here in the center, formed the target.

I observed —and you can follow my example now— that only a few of the alpha particles passing the gold atoms are scattered. But by far the most pass the layer of atoms without scattering. Just like in our wooden model. From this real experiment, we can deduce the structure of the gold atoms.

You see, that the mass of the atom is concentrated in a very small volume, which I will call the nucleus. It is the small darker circle placed in a large, lighter, almost empty sphere, which does not deflect the alpha particles.

So, we get an idea of the atom's structure. In the center of each atom is a nucleus, which is 100,000 times smaller than the atom itself. It is made of protons which are positive and neutrons which are neutral. Outside it are small electrons, negatively charged, on planet-like orbits (*Looks up towards heaven.*) – Bohr excuse me. And it is these orbits which make the size of the atom.

Geiger: In a further experiment, I can even show you these little electrons **directly** over here.

Exp: Helmholtz coils (see App. A.5)

Geiger: Lets have a look on the screen: you can see a vacuum tube which is filled with a very small amount of air. In this vacuum tube we have an electron gun that is shooting electrons upwards at high speeds. You can see them as this blue line.

(Showing with a laser pointer the straight line of electrons in the dark.)

Geiger: These accelerated electrons collide with the remnant air and make it glow. ...

Lorenzo: So we see the excited atoms that the electrons have bumped into along the way?

Geiger: Exactly. Now let's see what I can do with the electrons ...

(Mission Impossible music starts playing, bends electrons to circles of different radii.)

Maike: How do you do that?

Geiger: Let the camera zoom out. Outside the tube you can see we have two coils. These are simply copper wires, wrapped up many times. When an electric current flows through them, they generate a homogeneous magnetic field. Since the electrons are electrically charged and moving, the magnetic field bends them onto curved paths. You saw, if I changed the field I could make the circle bigger or smaller.

Lorenzo: Okay, so now we understand the structure of the atom and we know that we are all made of them.

Maike: But where does the mass of the atoms come from?

Rutherford: Ah yes, your original question. Well **your** mass is simply the sum of the masses of your atoms. There are very very very many atoms inside you. But they each have an incredibly tiny mass. Inside the atoms the mass comes almost solely from the protons and neutrons. From the nucleus. The electrons, which we saw here, make up less than 1 part in a thousand and are just along for the ride.

Lorenzo: Have we made progress here? Where does the mass of the electrons, protons and neutrons come from?

Rutherford: (*shrugs*) I am the Master of the atom, but **even I** don't have a clue! Anyway – let me show you something funny. These atoms don't always just sit there and do nothing. There are several which are special. Like the Radium I showed you in my scattering experiment. They spontaneously send out energetic particles. They are radioactive.

(*They walk over to radioactivity experiment.*)

Rutherford: The radioactive material we use here is very safe. Don't be afraid, their range in air is only about a few centimeters. (*To the audience.*) There is nothing to worry about. (*Back to visitors.*) But I will let my assistant perform this experiment.

Exp: Radioactive decay and Jakob's ladder (see App. A.6)

(*Caretaker re-enters stage and carefully observes the experiment.*)

Rutherford: What we have here are two bent wires with a high voltage between them. Look, what happens when we light a match at their closest point.

(*The match is lit and we see the extended spark rising through the wires.*)

Geiger: The heat of the match separates the electrons from the atomic nucleus. This makes the air electrically conducting, so that a flash between the wires is triggered.

Rutherford: And now, let's see what happens with this radioactive source Geiger is holding in his hands . . .

(*Spark is triggered by radioactive source*)

Geiger: The little dot at the tip of this tube is emitting nuclei of Helium, so-called alpha particles, at a very high energy. They can also separate the electrons from the atoms in the air. The voltage then causes a lightning flash. Since the air inside gets very hot, it rises upwards.

Rutherford: Ah, he is a good one our Hans! This is a way to detect little particles that you can otherwise not see with the naked eye. Geiger, you should work on such a detector.

Geiger: (*Turns away from Rutherford, mutters in a lower voice.*) Yes, but I will call it Geiger-Counter...

Lorenzo: Ernest, thank you so much for your help. I guess we must find someone who knows the origin of the mass of all these protons and neutrons.

Caretaker: (*Claps his hands, Rutherford and Geiger freeze.*) Well, I guess this will take some t- i- m- e . . .

Maike: Oh it's you!

(*Caretaker walks towards Maike and Lorenzo, notices the radioactive sources and stops.*)

Caretaker: (*To the audience.*) If I may say something as well, Enrico Fermi, in Rome at the time got the Nobel Prize in 1938 for his work on radioactive materials! (*Taps on Geiger's shoulder.*)

(*Show slide with picture of Enrico Fermi.*)

Caretaker: (*To Maike and Lorenzo.*) Unless you want to wait for 40 years – let's see if I have another shortcut for you . . . (*Finds another umbrella in his box.*)

Lorenzo: Just a second. Here, Geiger, have some gummy bears from Bonn. (*Puts some gummy bears in Geiger's pocket.*) They are from the future. And they are delicious. Good byyyyyyyyyeeeeee....

(*Maike & Lorenzo spin the umbrella...*)

4.3 Berkeley, California

(*Maike, Lorenzo and the Caretaker step into the new space, highlighted by the spotlight. Ernest Lawrence and his female assistant, frozen in their lab.*)

Caretaker: Here you are in Berkeley, California. The time (*Checks his funny watch.*) is 1952. Before you, you see Prof. Ernest Lawrence. He is the all time-expert on particle accelerators. This here, hmm, is one of these assistants you have never heard of. Here is the next step on your quest. (*Briefly claps hands twice.*)

Maike: Hello, this is Lorenzo and I am Maike. We are from Bonn.

Lawrence: Oh, Bonn, where Wolfgang Paul just became the director of the Physics Institute!

Lorenzo: Indeed! Can you maybe help us understand matter and find out where mass comes from?

Lawrence: Yes, welcome, you have certainly come to the right place here in my laboratory, in Berkeley California. Before we come to your question, let us look at some new particles you might not have heard about.

(*They walk to the cloud chamber.*)

Lawrence: Here, I have an interesting detector. It is called a cloud chamber. It can “see” some of the smallest particles we know. We have mounted a camera, so up on the screen you see the paths of the particles live as they come in.

Exp: Cloud chamber (see App. A.7)

(While Lawrence explains cloud chamber, Maïke and Lorenzo go oooh and aaah.)

Lawrence: Those fat long straight lines are protons, you have maybe heard about. The really fat short lines are helium nuclei, also called alpha particles. That is what Rutherford used, to do his famous experiment. The longer squiggly lines you also see here are electrons (some of them are also positrons, the anti-particle of the electron). And all these particles come from cosmic rays, from outer space. We are not producing them here. And they fly through everything.

(Caretaker claps twice, Lawrence and assistant freeze. Man in Black Suit, white shirt, dress hat, and sun glasses walks in from audience. He addresses the audience. See Fig. 9.)



Figure 9: Blues Brother (HKD) on the balcony in the Padua lecture hall.

Blu Bro: You mean these cosmic rays come from the universe and they fly through everything? They fly through **Y O U!** (*points at Lawrence*), **M E!** (*points at himself*), **T H E M!** (*points at the audience*),
E V E R Y B O D Y!! E V E R Y B O D Y!!

(Music from Blues Brothers: Everybody Needs Somebody, karaoke version. Man, Maïke and Lorenzo start singing.⁴ Caretaker claps again, scene comes back to life.)

⁴ *Everybody is bombarded // By the cosmic rays // They're from outer space // Did you know? (Man at Maïke) // I didn't know // What about you? (Man at Lorenzo) // Neither did I // What*

Maike: You mean we are constantly bombarded by all this stuff.

Lawrence: Yes.

Lorenzo: And what are those long straight thin lines? They seem to happen quite often.

Lawrence: Yes, very good. Those straight lines are **muons**. They are a totally new kind of particle. They live only very briefly, but you can see they are still out there. They were discovered here in California. This muon is 200 times heavier than the electron, but otherwise basically the same.

Maike: Aha, so the muon is just a big brother of the electron, but what is it actually for?

Lawrence: The simple answer is: we have no idea. You could say: it is matter but it doesn't matter.

(Lorenzo laughs briefly but hysterically at the joke.)

Lawrence: It is too short lived to be of relevance for stable matter, like us. Then again, maybe it is an important piece in the matter puzzle.

(Caretaker takes folded newspaper out of his overcoat pocket and starts reading.)

Maike: Ah, that's interesting, are there more of these unusual particles?

Lawrence: Yes, come look at this experiment, it shows that it is *even more* complicated: anti-matter! Every particle has an anti-particle, it is equal in mass but opposite in charge. These are safe sources, but my assistant Jacqueline will perform the experiment.

Jane The name is Jane.

Lawrence: Yes!

Exp: Experiment with Sr-90 (β^-) and Ge-68 (β^+) in magnetic field (See App. A.8 and Fig. 10.)

(Assistant performs the experiment while Lawrence explains.)

Lawrence: The first radioactive source emits fast electrons that are detected with the Geiger counter.

(Spotlight on Geiger who briefly appears from the side door with a big smile.)

about you? (at the audience) // They go through you, you, you! (3 times) // In the airplane // you get even more! // Sometimes I feel // I feel a little muon inside // when it flies through my body // I never ever ever have a place to hide. // (music) // Sometimes I feel // I feel a little muon inside // when it flies through my body // I never ever ever have a place to hide. // They go through you, you, you! (3 or 5 times)



Figure 10: The beta-decay matter and anti-matter experiment, with JSch-R (Jane) and LU. The orange box is the Geiger counter. The black object underneath and slightly to the left is the magnet. One source is the silver pen in JSch-R's right hand. The other source is in the glass.

Lawrence: If we now insert the source in a magnetic field we hear that the clicking decreases. Where did the electrons go? We can try to detect them above the magnet. (*Assistant moves the Geiger counter above the magnet.*) Nothing. Let's try below the magnet. (*Assistant moves the Geiger counter below the magnet.*) Now we hear the clicks again! The magnet bends the electrons downwards.

Maike: (*To Lorenzo.*) Just as we bent the blue electron ring in the cathode ray tube?

Lawrence: Indeed. The second source emits positrons, the anti-particles of electrons. Again, we can detect them with the Geiger counter. When we put the source in the magnetic field the clicking decreases. Let's see if we find them where we found the electrons previously. (*Assistant moves the Geiger counter below the magnet.*) No, they are not there. Let's try above the magnet. (*Assistant moves the Geiger counter above the magnet.*) Here they are! They have positive charge, so the magnet bends them upwards!

Lorenzo: Anti-matter... Awesome! (*To Maike.*) Maybe I can finally build my own warp drive!

Maike: Forget it Lorenzo! There is a much better use for that. Antimatter is used in medical imaging, they call it positron emission tomography (PET). But coming back to our original question, we wanted to learn about the proton ...

Lawrence: Sorry, I have seemingly digressed with all these particles. Right, you wanted to look inside the proton. For that we need accelerators.

Maïke: Accelerators? Why can't we just take a microscope?

(Caretaker yawns, lays down with the hat over his face and falls asleep.)

Lawrence: Well let me first explain how a microscope works. *(Points to slide with image.)* It sends light waves onto a sample. The light then goes through these lenses and reaches our eye. We can only see the object, if the wavelength of the light is *smaller* than the size of the sample. Here, I have an experiment with water waves. As I am allergic to manual labor my assistant Simona will demonstrate it to you.

Jane The name is Jane.

Lawrence: Yes yes.

Exp: Water waves (see App. A.9)

Jane Here I have a water bath with a light underneath. Through the mirror I am able to project the reflection of the water onto the screen. When I switch on the wave generator, you can see the waves moving across the surface, projected onto the screen. Let's now see what happens when I put this large object, *(Holds it up into the spotlight.)* larger than the wavelength, in the path of the waves.

(Music: Surfin' USA. Maïke and Lorenzo dance.)

Maïke: Ahhh, I see how the object blocks the path of the waves. So if you sit behind it you can see where it is, from the wave pattern behind it. *(Points on the screen with laser pointer.)*

Jane Exactly! But now see what happens if I put a smaller object in there. An object, which is smaller than the wavelength.

(Music: Surfin' USA. Maïke and Lorenzo dance.)

Maïke: Mhh, the waves reunite and there is no distortion in the pattern further back.

Jane Yes, very good, that is our problem. As soon as the object is smaller than the wavelength we can not see it anymore. The waves just go around it. But now in our wave bath we can increase the frequency, and thus decrease the wavelength. *(Cranks up the wave generator.)*

Now, you can see the distortions in the back again!

Maïke: So why don't we just increase the frequency of the light in our microscope, in order to see the smallest particles?

Jane For technical reasons it is not possible to do that with light waves. Instead we use the method Rutherford also used in his famous experiment.

(Spotlight on Rutherford who briefly appears from the side door with a big smile and triumphantly raising his hands.)

We use particles instead of light. When one looks very close at a particle it becomes wavelike. So we can decrease the wavelength of the particle to get a better resolution. To get a smaller wavelength we have to increase the energy of the particle. So we want to accelerate particles to high energies.

(Caretaker stands up slowly, has a stretch, walks to Lawrence, takes a cup out of his overcoat pocket and drinks.)

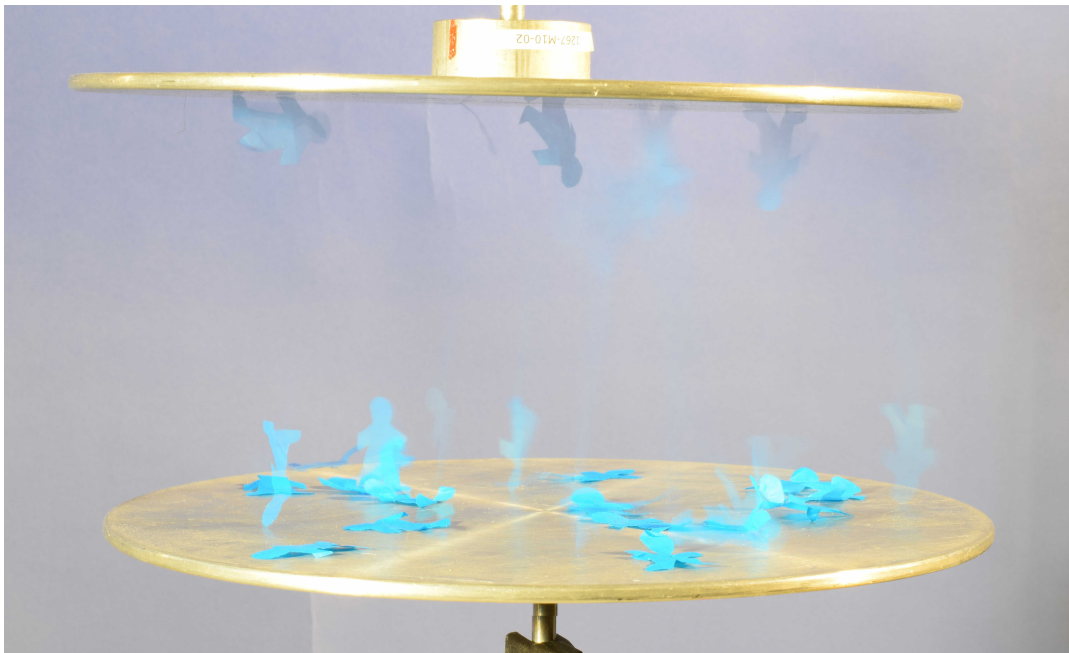

Figure 11: Dancing paper men experiment. The picture is taken with a high exposure time to capture the motion of the dancing paper men. See also the setup in Fig. 46.

Maike: Now I get it, you accelerate the particles to higher and higher energies to see smaller and smaller particles. ... But ... how do you accelerate them?

Jane That is easy, we just use an electric field. I can show you that with another experiment.

Exp: Plate Capacitor (see App. A.10 and Fig. 11.)

Jane Here I have a large plate capacitor. The lower plate is connected to Earth. I shall put some Italian soccer players on it.

Maike: Soccer players?

Jane Well, a paper version of the Italian soccer team. That is why they are blue. Now I use this cat fur to rub electrons onto this plastic stick. From there I put them on the top plate. ...

(Paper people start dancing to music. Lawrence and Caretaker move slightly up and down with the beat.)

Lorenzo: Wow ..., but why did they keep falling down?

Jane Have you ever seen the Italian soccer team play? ... No, with the plastic stick the top plate got charged negatively. The bottom plate and the paper people then get charged positively. Due to the difference in charge the paper people get attracted and rise to the upper plate. There, by contact they get negatively charged and are attracted downwards. Then the same process starts again.

(Caretaker offers a part of his newspaper to Lawrence and starts reading again.)

Lorenzo: Amazing! But they just go up and down. How can you achieve higher energies?

Jane Well, for that we simply use several capacitors in a row. Here I have this linear accelerator.

Exp: Linear electric Accelerator (see App. A.11)

Jane It has these copper strips which I will charge, alternating positive and negative. To power the whole thing, instead of killing more cats, I use this modern machine (*See Fig. 48.*), which I hook up here. Inside the accelerator I place these conducting balls. (*Runs the machine to music.*)

Lorenzo: Interesting, that is pretty good. But to be honest, that doesn't seem very fast.

Jane If you want to reach really high energies, you would have to build a much longer accelerator. To get the required energy it would have to be several kilometers long ... that doesn't seem feasible.

Lawrence: Yes yes yes, thank you Sue, but to solve this problem, I Ernest Orlando Lawrence have invented another kind of accelerator. (*Raises circular accelerator.*) Here the particles are accelerated in a circle, so I called it a circular accelerator.

Maike: To me it rather looks like a huge salad bowl.

Exp: Salad bowl Circular Accelerator (see App. A.12)

Lawrence: Well, it's an accelerator! It is very similar to the linear one with alternately charged copper strips. However, instead of using that old fashioned machine, I use something modern, which comes out of this box. It is called *electricity*. Furthermore, I also need a conducting ball to place inside. (*Takes a ball from the linear accelerator and runs the circular accelerator to music.*) And you see the ball travels on a circular path.

Lorenzo: Ahh that is cool, so you can accelerate the particle again and again, and you don't lose any. That is very clever. But, I have a question, in this experiment, you change the charge of the ball each time it crosses a copper strip, right?

Lawrence: That is correct.

Lorenzo: Is that also possible with real particles?

Lawrence: No, unfortunately not. An electron is always negatively charged, and a proton always positively. In real particle accelerators we have to change instead the electric fields, just as the particle passes. We also have an experiment to show this. It is a mechanical analogue, using the gravitational field. My assistant Francesca can explain this.

Jane The name IS Jane.

Lawrence: Yes, yes...

(Two people carry in the mechanical synchrotron model to music. The Caretaker assists.)



Figure 12: Mechanical synchrotron. The balls are released on the left and then raised at the right time where the slightly wider aluminum supports are. From left to right we have JSch-R, MH, LU.

Exp: Mechanical synchrotron model (see App. A.13 and Fig. 12.)

Jane This is a mechanical accelerator. I can let a ball roll down from this one end. Then there are three points where the rail can be raised manually to accelerate the ball. I could use your help, would you mind?

(Maike and Lorenzo assist with the accelerator. Lorenzo gets it wrong the first time and looks clueless.)

Lorenzo: Hmm, did I do something wrong?

Jane Yes Lorenzo. You have to raise the track as the ball rolls by! It's not that difficult. Should we try again?

Lorenzo: I'm sorry. Yes, let's do it again.

(The second time Lorenzo does it right. They repeat it a third time too.)

Jane Here we have accelerated the ball using gravity. In a proper accelerator I would have to switch the electric field as the particle goes by. I would have to synchronise it with the particle's flight. That is why such a machine is called a synchrotron.

Lorenzo: Oh, now I understand! So, in a real accelerator you have to switch the electric field just in the instant when the electron or proton is flying by? Oh, and by doing it in a circle you just sit there and wait every time it comes by. And you also don't lose any! Clever!

Jane Exactly! Let me show you what a real accelerator looks like.

(Project on to the screen a photo of the ELSA accelerator in Bonn.)

Maike: Isn't that the ELSA accelerator in Bonn? It must be a very intricate machine! And how fast are these particles going?

Jane These particles rapidly reach speeds close to the speed of light. Speaking of light, let me show you an experiment, just for fun. Maybe one of you could assist me.

Lorenzo: Me, me, me!

Exp: Flour explosion (see App. A.14, and Fig 13.)

Jane We call it flour power.

(Caretaker claps twice, scientists freeze. Caretaker brings new Umbrella.)

Caretaker: I think it is time to move on. You've just learned how to construct a microscope to look at the proton. Now you should go see one in real life. *(Maike and Lorenzo start to spin the umbrella.)* This will be a more complicated intercontinental, space-time travel, and will take some **t i m e**. Maybe 5 minutes. We will take a short break, but please remain seated.



Figure 13: Burning flour cloud with Sina Kürtz on the left and DH on the right. The cut-off PET bottle is filled with flour. The latter is ejected upwards, by blowing through the red rubber hose. The floor is covered by a fire-proof tarp. This is from a different Bonn physics show. Photo by Volker Lannert.

4.4 DESY, Hamburg, Germany

(Sau Lan Wu and Haimo frozen in their lab. Caretaker, Maike and Lorenzo arrive. Maike and Lorenzo have their clothes swapped, i.e. Lorenzo is wearing a dress. Maike and Lorenzo look at the other and then themselves.)

Maike: What happened? Oh no, look at you!

Lorenzo: And you!

Caretaker: Hmm, it seems something has gone wrong.

Lorenzo: Very wrong!!

Caretaker: Did you maybe spin the umbrella the wrong way? Or maybe you have crossed a worm hole on the way...

(Maike and Lorenzo shrug helplessly.)

Caretaker: Anyway, the quest must continue! Lorenzo, be a man ... or whatever. *(Pause)* So, welcome to Hamburg, Germany! Here we are in the international research center DESY. The time is 1980. These are Sau Lan Wu and her assistant Haimo Zobernig, they will be able to help you to answer your questions about the proton. *(Caretaker claps twice; Sau Lan and Haimo come to life. Caretaker steps to the back of the stage and stands motionless like a guard.)*

Maike: Hello Ms. Wu, Hello Haimo!

Sau Lan: Huh? Hello! Who are you??

Maike: This is Lorenzo, I am Maike, we came from Bonn on a journey through space and time.

Sau Lan: Oh, Bonn, isn't that where Wolfgang Paul built the first strong focusing electron accelerator in Europe?

Maike: Yes!

Sau Lan: *(Looks at Lorenzo.)* Is that trendy in Bonn?

Lorenzo: *(Embarrassed)* Ehm, this is German fashion from the future... *(Pauses)* Can you help us with our quest? We want to know what the proton is made of and where mass comes from. A simple answer would be much appreciated... *(Sighs, looks at audience for approval.)*

Sau Lan: Well, to study the proton, or to look deep into matter, you need large accelerators. They are like our microscopes.

Maike: Oh, Mr. Lawrence in Berkeley told us about those... but what happens when you actually want to look inside? How can an accelerator be like a microscope?

Sau Lan: My assistant Haimo will show you a simple accelerator we have built!

Exp: Vacuum cannon (see App. A.15, and Fig. 14.)

(Caretaker is interested in the experiment.)



Figure 14: Haimo Zobernig (MBr), ready to fire the vacuum cannon.

Haimo: This experiment consists of three parts: the accelerator, the detector, and this ... box. The accelerator in this case is just this hollow metal pipe. Connected to it is this vacuum pump. On this side, we put in our projectile, this wooden ball! And then ... and then ... hmmm?

Sau Lan: ...Haimo, we need a target that we want to investigate!

Haimo: ..Oh, yes, right, uhm....

Caretaker: Maybe I have something you can use. *(Takes Quark out of his "Lost & Found" box.)* I just bought it in a local supermarket. It is full of something called "Quark". *(Gives it to Haimo, who holds it in front of the camera, to prove it is Quark. Then puts it inside the detector.)*

Haimo: Yes, yes, this is our target and it will do just fine as a model of a proton! We put it right here in the detector. Okay, now we seal the pipe on both ends and start

the vacuum pump. When the pressure is low enough, I will remove this cap and we will see what happens.

(Big bang, when quark explodes.)

Caretaker: *(Frowns upon realizing he has to clean up everything. To himself:)* I have made a huge mistake....

Sau Lan: Lorenzo, would you like to read out the detector?

Lorenzo: Can you eat that?

Sau Lan: Sure. *(Tries some of the quark.)* But it tastes a bit **strange** to me.

Maike: Hmm, no, I think it is **TOP!** *(Shows two raised thumbs.)*

Lorenzo: Delicious, this is such a **beautiful** experiment!

Sau Lan: You are so **charming**.

(Flash a slide showing the six quarks of the SM.)

Caretaker: *(Pulls an endless sheet of paper towel out of his “Lost & Found” box.)* Now I have to clean it **UP!** Then I’ll take it **DOWN**, to the basement.

(Caretaker starts to clean the detector with paper towels from his box and a large rubbish bag.)

Sau Lan: What we can actually see with this experiment is that protons are made of quarks. This was first seen with a huge electron accelerator in Stanford, California in the 1960s. Real accelerators are far more complicated since they don’t use vacuum technology for the acceleration.

Lorenzo: So what do these “quarks” look like? Like that cottage cheese? *(Points to remnants of the quark explosion, that the Caretaker is still cleaning up...)*

Sau Lan: No, that was just an analogy. But there is something unusual about these quarks, because you actually never see them separated, but only in pairs or triplets. Here, let me show you this little testicle model! *(Seductively plays with the balls.)*

Exp: Testicle Model (see App. A.16)

Haimo: The balls are enclosed with this elastic band. You see you can stretch it, but you can’t actually pull out an individual ball.

Lorenzo: Ouch! *(Touches his balls.)*

Maike: You baby! *(To Sau Lan.)* As you stretch the rubber skin it seems you must use more and more force. It gets harder and harder to pull them apart?

(Caretaker finishes cleaning the detector, moves it to the back of the stage and puts away the rubbish bag. Now he wipes Quark off the floor/tables circuitously.)

Sau Lan: Yes, exactly, and that is why even by pouring in more energy you can't see a free ball. This is the same for quarks. The whole model represents a proton with 3 quarks inside. These are held together by the strong force that is symbolized by the elastic band.

Haimo: It is different from the electromagnetic force. There you easily ionize atoms – separate electrons from the nucleus – to make the path of the electron visible in a cloud chamber!

Maike: So if it is impossible to pull out an individual quark, how do you know they are inside?

Sau Lan: Excellent question. Let me show you another nice experiment. Here we have this green balloon, which represents the original conception of a proton. Also we have this red balloon, which represents today's conception of a proton. We are now going to throw these balloons at each other to see how they behave. We could maybe use some help from our audience here! Who wants to come on stage? It's a very easy task!

Lorenzo: *(To kid from audience.)* What's your name?

Exp: Tossing Balloons (see App. A.17)

Sau Lan: Ok, you stay right here. So first, I'm going to throw the green, balloon. Could you please catch it and just throw it back? *(Throws the green balloon.)* Thank you, that was easy. It is just homogeneously filled with air. And now the red balloon... are you ready? *(Throws the red balloon.)* Alright, thank you! Big applause for N.N.! *(Pop the red balloon to reveal what's inside.)*

Haimo: As you could see, the balloon with solid balls in it behaved differently from the one only filled with air. In a similar way we figured out, that the proton must also consist of smaller objects! Of course at Stanford it was a bit more complicated, but the same idea.

Lorenzo: *(Plays with the testicle model, stretches the balls.)* Ok, I get the idea with these quarks inside the proton, but what about this force that holds them together?

Sau Lan: I have another experiment! Haimo, would you be so kind to explain it?

Exp: Air table and strong force (see App. A.18)

Haimo: On this table, we have three pucks, representing three protons. When we now turn on the air table, compressed air blows through many small holes in the table. Therefore the pucks glide frictionless over the table. The protons both carry a positive electric charge. We expect that they push off each other. This is realized by small magnets inside the pucks.

Lorenzo: Wait... but in a nucleus, there are many protons with equal charge, very close together! Now, how do you explain THAT?

(Caretaker unscrews the tip from his hat cleans it elaborately with a paper towel.)

Haimo: This can be explained by the strong force, which is symbolized by the velcro I now put on the pucks. It holds the protons together. At short distances it is very strong. But it drops off rapidly afterwards. If the protons are far away, the electromagnetic force dominates, so that the two protons are pushed off. But at very small distances, the strong force makes them stick together, just as the velcro. This way, protons inside a nucleus stay together.

Maïke: Ok, so the strong force doesn't reach very far, but when it kicks in, it is VERY strong. But coming back to your rubber model. How does this rubber skin look in the real world? What is it, that holds the quarks together?

Sau Lan: That is a very good question. We are now looking at particles that are very very small. Remember a human hair is already as wide as 40 trillion protons next to each other. And the quarks live inside such a proton. In this world the laws of nature are given by quantum theory.

Haimo: And in the quantum world, energy always comes in little packets, that have a fixed size. Let me show you this little experiment!

Exp: Photon Clicker (see App. A.19)

Haimo: The red laser light, that you can see here, consists of millions of millions of photons per second. Before this detector, I have some filters that block out the largest amount of those photons. The detector is hooked up to these loudspeakers. *(Turns them on.)* As you can hear, the loudspeakers crackle from all the photons. *(Then turns laser intensity way down.)* Now you hear individual clicks.

Lorenzo: Wow, so we can actually hear the individual photons arriving here in this little detector?

Haimo: Yes, that is correct. And this packet, the photon, which we only know as light so far, is also a force carrier of the electromagnetic force! We now know that every force has a force carrier.

(Caretaker finishes cleaning the tip and screws it on the hat. Then he stands motionless again.)

Sau Lan: For the strong force, this particle is called the gluon and was discovered by me here at DESY!



Figure 15: AF (right) and HKD (left) exchanging a medicine ball during the show in Padua. On the left in the back is MB as Haimo Zobernig and on the right is KH as Sau Lan Wu. Just to the left of AF you can see the air table of experiment A.18. In the background on the right is the Caretaker (JSchm) with a German spiked helmet.

Lorenzo: Really?

Sau Lan: Yes! ... Together with Haimo, and the others at DESY. Let me show you how these forces work! For this experiment we shall need the help of Herbi and Philip.

(HKD and AF come in on their inline skates, one of them carrying a 5 kg medicine ball.)

Sau Lan: As you can see they are wearing inline skates. *(They lift their feet for all to see.)* Furthermore, Herbi has a 5 kg medicine ball. This symbolizes the exchange particle, like the photon, or the gluon. They will now show us how they can exert a force on each other, without touching and instead using the medicine ball.

Exp: Tossing medicine balls on inline skates. (See App. A.20, and Fig 15.)

Sau Lan: As we have just seen, the medicine ball exchanges a force between those two, which pushes off these two physicists, just like the two positive charges repel each other! The gluon inside a proton does the opposite, it makes the quarks stick together. The strong force is essential to hold the quarks inside the proton and the neutron together. So they don't fall apart. It is also essential to hold all the protons and neutrons inside the nucleus together. Unfortunately in our analogy, we can not do an attractive force.

Haimo: Surprisingly it is this interaction of the quarks and the gluons which is responsible for the main part of the proton mass! That is about all we can teach you about

this.... We still do not have a full understanding of how this all works. It is one for the theorists, so it could take forever! But... since you are here... have you ever been inside a big collider?

Lorenzo: No, can we go there? That would be really cool.

Haimo: Well, no, but I can show you what it feels like to be accelerated to a velocity close to the speed of light, just like the particles inside the accelerator. Lorenzo, sit down on this bicycle.

Lorenzo: Bicycle? I mean I am pretty fit (*Flexes his non-existent muscles.*), but a bicycle at the speed of light? Do I need to swallow some drugs first?

Haimo: No, no worries, a few espressi are enough. Just go on! At the bottom of the screen you will see, at what speed you are driving!

Exp: Relativistic bicycle (see App. A.21, and Fig. 16.)



Figure 16: LU on the relativistic bicycle, for details see A.21, during rehearsals at Oxford University. Next to him is JM. In the back is MBe at the table where the lighting, sound, music and the projection are controlled.

Lorenzo: I have a fixie at home (*Swells his small breast.*) ... (*hushed voice*) it's actually illegal, but kind of fun. (*Starts pedaling.*) Whoa! Kind of psychedelic! Help!

Haimo: That's what Einstein told us about how the world works close to the speed of light. The faster you go, the more the world stretches around you!

Lorenzo: Wow.. that was quite something! We have learned a lot about the strong force here, and now we know where most of the proton mass comes from.... But we still don't know where the quarks themselves get their mass from!

(Caretaker claps his hands. Sau Lan Wu and Haimo Zobernig freeze.)

Caretaker: At this stage of knowledge and in order to find the answer to your initial question, you need to return to the present.

(Maïke and Lorenzo do the umbrella thing.)

4.5 CERN, Geneva, Switzerland

(A big dark hall, with a large photo of the Atlas detector on the back wall. The spot is on the Caretaker, Maïke and Lorenzo.)

Caretaker: Here we are at CERN, the center of the particle universe. This is where Carlo Rubbia, from Pisa, discovered the W -boson, for which he got the Nobel Prize in 1984. The time is 2012. We are in the LHC tunnel, the tunnel of the largest machine ever built. I hope, these two "scientists" can help you with your questions about the quark mass. Good luck! (*The Caretaker claps his hands twice, the stage is now fully lit, the scientists come to life. The Caretaker takes a folding rule out of his overcoat pocket and measures something.*)

Good Scientist.: Huh? Did you see that? I have no clue how *they* (*Points at them.*) got down here but since they are here ...

Bad Scientist. ... we can use their bodies to conduct some very important studies on the influence of deadly radiation!

Good Scientist.: No! We can't test radiation on them. We would **never** do that.. at CERN. In fact, it is impossible to power up the accelerator if anybody is down here.

Bad Scientist. (*To Good Scientist, asking.*) Feed them to my pet black holes?

Good Scientist.: No! No the courts have decided, we do not make black holes at CERN!!

Bad Scientist. (*To Good Scientist, pleadingly.*) But then can we at least test the deathly laser turrets on them?

Good Scientist.: (*to Bad Scientist*) No!!! Cut it out! You are embarrassing us. There aren't any laser turrets either.

Lorenzo: Hello! Excuse me. Helloo! Sorry, this is Maike and I am Lorenzo. We are from Bonn.

Good Scient.: Oh from Bonn, the home of the physics Nobel Laureate Wolfgang Paul. Welcome. Can I help you with any questions you may have about CERN and the LHC?

Maike: Wow! That would be great!

Bad Scient. CERN, the center of the universe. Where we created the biggest man-made (*Looking at Maike.*) or even woman-made!, bang!

Good Scient.: (*Rolls eyes*) Right. So, here we are in the LHC tunnel. The LHC was built by more than 10,000 scientists and engineers from over 100 countries. (Important large contributions were made here in Oxford/Padua.) The LHC tunnel is a circle with 27 km circumference. It is about 100 meters under ground. Let me show you a film.

Exp: LHC Film

(*Caretaker notices the glass of wine and examines it in detail.*)

Lorenzo: And what is so special about this LHC accelerator?

Bad Scient. In the LHC we accelerate protons to very very very very very very very high energies, actually the highest particle energies ever achieved by man or (*looks at Maike*) woman!

Maike: And how much is that very very very very...?

Bad Scient. very very very.

Consider this lovely experiment. This is a special kind of transformer that has many many many many many coil windings on the upper side but only a few on the lower side. Let's see what it can do:

Exp: Tesla Transformer (see App. A.22, and Figs. 17, 18.)

Good Scient.: Those lightning bolts were discharges of about 200,000 volts. At the LHC we have energies which correspond to a potential of 4 trillion or 4 million million volts!

Bad Scient. And as you saw in the film, we accelerate protons to these energies going around clockwise and also another set of protons going around counter-clockwise.

Lorenzo: This seems pretty silly, who cares which way they go around?

Good Scient.: Well let me show you this wonderful historic experiment we borrowed from our colleagues at DESY, in Germany.

Exp: Vacuum Cannon exhibited

(*Caretaker starts playing with two balls, throwing/catching/juggling.*)



Figure 17: TL and CSch as the two CERN scientists in the Padua show. Between them our Tesla coil. To the right is the Caretaker (JSchm) placing the glass of water which is needed later.

Lorenzo: Ahh, we already know that.

Bad Scient. Oh damn! I was so hoping we could do this again. . .

Good Scient.: Anyway, let me use it for the argument I wish to make. Here you accelerate the particle and shoot it at this target. We call it a fixed target experiment, because the target, the quark, does not move. The target is big and massive and you are sure to hit something, and you are also very likely to have an interesting reaction, as you saw.

Lorenzo: That makes sense and seems very practical.

Bad Scient. But as you maybe noticed, almost all the Quark flew forward. A large part of the energy of the accelerated particle can not be used to “bang” ... part of the energy is required to maintain the forward motion.

Maike: Hmm, so what if you bang two moving things together? (*Bangs her fists together.*)

Bad Scient. Yes, excellent! That is exactly what we do here at CERN. This way there is no net motion. I can convert the full energy into something new, like a big fat owl.

Lorenzo: Ok, that’s really cool. So if we take these two balls (*Points at the Caretaker, who brings him the balls.*) and bring them up to super duper speeds and then ... Can we maybe try it out ... right here?

Good Scient.: Sure.



Figure 18: Tesla coil during discharge.

Bad Scient. Let them bang!

Exp: Balls I (see App. A.23, and Fig. 19.)

(Maïke and Lorenzo throw a ball each. Try it twice.)

Lorenzo: Hmm, that didn't work so well. How do you make sure that you have collisions? Do you keep shooting until they hopefully actually hit each other?

Good Scient.: Well we are a bit smarter here at CERN than you. We don't send individual protons around the ring. We use bunches.

(The Caretaker pulls out two large boxes full of colored plastic balls, gives one to Maïke and one to Lorenzo.)

Exp: Balls II (See App. A.23, and Fig. 20.)

(“splat!” “kaboom!” . Both as comic book pop art on screen.)

(The Caretaker sweeps the balls away.)

Maïke: That worked much better. I even saw some collisions! *(Stops, turns to the audience, whispers.)* did you?



Figure 19: First step: Hit single balls (protons) onto each other. On the left MH, on the right LU. Between them further back CSch further back the Caretaker (JSchm) with a hard hat.



Figure 20: Second step: Hit two boxes of balls (bunches of protons) onto each other. To the left MH, to the right LU. Between them the two CERN scientists (CSch, TL). In the far background the Caretaker (JSchm).

Lorenzo: Ok, so what do you use the LHC for?

Bad Scientist. Haven't you heard: we have made **T H E H I G G S B O S O N**. We discovered it in July, 2012, here at CERN, with the LHC!

Lorenzo: What? You have discovered the Higgs boson?

Bad Scient. Exactly.

Lorenzo: Wow, the Higgs Boson, Maïke, the Higgs boson. That is amazing, Ye-haw! (*Music! dances a jig with Maïke. The caretaker and the CERN scientists join in.*) The Higgs boson!
(*Music suddenly stops. Everybody freezes. Lorenzo calms down, stops, thoughtful, and slowly.*)
But what actually *is* the Higgs boson?

Bad Scient. I was hoping you might ask that. (*Triumphantly:*) So the Higgs boson is a quantum manifestation of the Higgs field!
(*The Caretaker continues sweeping the balls.*)

Lorenzo: A quantum what?

Good Scient.: Yes, do you remember the photon?

Lorenzo: Oh yes, we “heard” the photons click, back at DESY.

Good Scient.: The photon is the quantum, the smallest packet of the electromagnetic field, which is a vector field.

Lorenzo: Oooookaaay.

Good Scient.: Similarly there is a Higgs field and the Higgs boson, which we observed, is the quantum, the smallest packet of the Higgs field. The Higgs however is a scalar field.

Lorenzo: Quantum? Scalar?? Bosons??? Oh boy! I need some more gummy bears...

(*The Caretaker pulls a Haribo bag from his pocket and gives it to Lorenzo, who starts eating.*)

Good Scient.: Let me begin by explaining what a field is. Let’s start with an electric field. Which is a vector field. On the screen you see two electric charges, one positive, one negative, see Fig. 21. Between them an electric field forms, represented by the lines with the arrows.

(*To Lorenzo*) Sorry, would you mind to stop eating and actually listen? Thank you.

So, if I put something that is charged inside the field, it gets a property which has not only a value, but also a direction. Hmm, why don’t we demonstrate that here with you? Please stand at these two sides of the stage.

(*The Caretaker and the Bad Scient. hand charges to Maïke and Lorenzo.*)

Exp: Paper electric field and acceleration of one charge (see App. A.24, and Figs. 22, 23.)

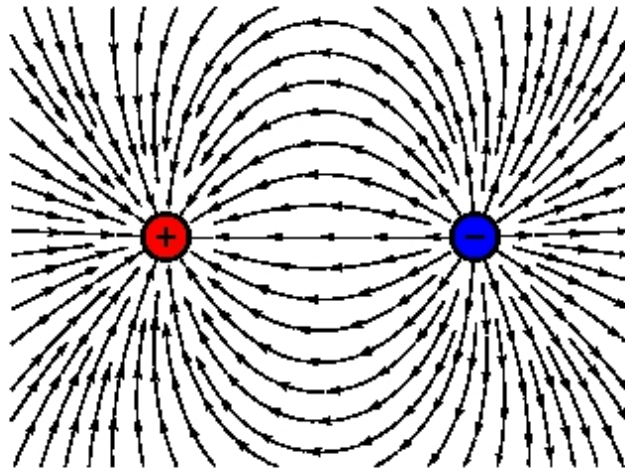

Figure 21: Graphical depiction of the electric field between two opposite charges. Image made using Mathematica.



Figure 22: Setup for the electric field demonstration. On the left MH with the minus sign. On the right LU with the plus sign. In the middle TL with a minus sign. At the back, at the blackboard, CSch.

Good Scientist.: So now I am charged myself. I sit in the field you generate and feel attracted to *Maike*. So I start moving in her direction. But since you are only very weakly charged the energy I get is low, so I move slowly. Now, if I just flip my charge I am attracted towards *Lorenzo* and I move that way, but my speed stays the same as before.

(The Caretaker takes the gummi bears from Lorenzo and gives some to camera / technicians / audience / ...)

Good Scientist.: Now if you double the charges you are holding, the field gets stronger. So my energy (or your attraction) is larger and I am moving faster. *(Runs once back and forth between Maike and Lorenzo.)*

Good Scientist.: And finally if you create a very strong field *(Maike and Lorenzo hold up many*



Figure 23: In the left photo MH with a single positive charge. Unseen to the right is LU with the corresponding single positive charge. TL as one of the CERN scientist places himself with a probe negative charge inside the resulting electric field. In the right photo Lorenzo has dramatically increased his negative charge and thus the resulting electric field.

many charges.) I will be very fast! (*To audience.*) You'll have to watch carefully! One!–Two!–Three! (*On the count of Three flips charges back and forth once but does not move.*)

Maike: You are indeed very fast! So we have understood, that ... if a particle interacts with a vector field it gets a property which has not only a value ... but also a direction, right?

Exp: Scalar field analogy, weather map of Italy. (See App. A.25, and Fig. 24.)

Bad Scientist. Yes, exactly, but for a scalar field this is different. Let us consider the temperature, as a field. This is shown here on the screen with a map of Italy (Fig. 24). The temperature is a scalar field. If I now take this glass of wine ... (*Looks more closely at the glass.*) Oh, ... it is only water (*Looks up at the audience.*) has anybody seen Jesus?

No matter. If I put this glass in Padua, the water will take on the local temperature of 12 degrees. A property, but no direction!

If I put the glass instead in Rome, it will take on the local temperature of 14 degrees, again a property, but no direction.

Salute. (*Drinks from the glass.*)

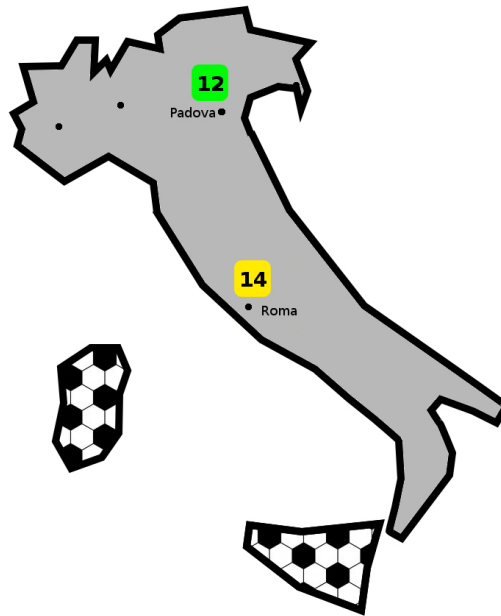

Figure 24: A temperature map of Italy.

Lorenzo: Ok, ok, ok, this is all a bit much for me. What does this have to do with the Higgs boson?

(The Caretaker tries to compare the height of Maïke and Lorenzo with the folding rule.)

Bad Scient. Let me take this blue cloth. It shall symbolize the Higgs field. I shall also need the help of two assistants.

(Helpers get on stage.)

Bad Scient. Nature has decided that the Higgs field should **always be everywhere**. So imagine this cloth all through space and **eternally** billowing and fluctuating.

Exp: Higgs Field and black cloth (see App. A.26, and Fig. 25.)

Bad Scient. As particles move through this background scalar(!) Higgs field they also get a property, and that property is *(Wait for it, thumps his belly)* MASS!

Lorenzo: Mass? We have been wondering about mass on our whole journey. So it is related to the Higgs field and not to red gummy bears! *(Looks at caretaker menacingly.)*

Good Scient.: Yes, different particles interact differently with the Higgs field. And the property they get from interacting with the Higgs field is universal: everywhere and eternal. So it is its own! *(The two people are still making waves with the blue cloth.)* Here, this small sheep represents an electron, it has a small mass, it interacts weakly with the Higgs field. ... This stuffed owl, however, represents a massive top quark this interacts much much much much stronger with the Higgs field and is thus much heavier!



Figure 25: Light particle (small plush sheep) moving through the Higgs field.

Lorenzo: So the particles get their different masses by how they interact with the Higgs field?

Good Scientist.: Yes, exactly! Just like here:

(The Caretaker lays a path on the floor with the folding rule and follows it with large steps.)

Exp: Eddy current experiment as a Higgs field analogy (see App. A.27)

Bad Scientist. I have here a simple metal bolt. I also have a small magnet, which you can see, holds up this screwdriver. Finally I have a hollow aluminum tube ... which is NOT magnetic

(Holds magnet against tube, it doesn't stick.)

This aluminum tube shall represent the Higgs field.

(First drops metal bolt through the tube, into a plastic cup below.)

So the soulless metal bolt flies through uninhibited: this represents the massless photon. It does not interact with the aluminum tube, the Higgs field.

(Next drops the magnet through the aluminum tube, it falls very very slowly.)

The magnet however interacts with the metal tube, creating a current in the tube, this causes the magnet to fall slowly, this is then a massive particle.

Maïke: OK, but now what about the Higgs particle?

Bad Scientist. Recall: the Higgs particle is the excitation of the Higgs field. So we must excite the Higgs field, and if we do this strongly enough, well then we should produce a Higgs boson.

Lorenzo: Can you do that here?

Bad Scient. Yes, I shall excite the field ...
(Pulls out two heavy hammers.)
with these hammers. But I will also need a lot of energy. So I will need all of your help.

Lorenzo: Maybe we should count together!

Bad Scient. *(With Lorenzo and the audience.)* One!–Two!!–Three!!!

Exp: Hammer to cloth, produce a green frog, as the Higgs boson.

Maike: Wow, so we have **finally** understood the mystery of mass and the Higgs boson. Yeah! Time to head home, no?

Lorenzo: Yes! No, Wait! One last question. So how did you do **that** here at the LHC?

Good Scient.: Well, you saw! With this giant collider we have smashed together protons, right here, in this spot. On several very very very very rare occasions we then produced a nice fat Higgs boson. The Higgs boson lives for a short bit and then **“POOF”** decays. And we can see the decay particles....*(Rotating yellow lights go on, a warning horn sounds.)* Oh no, get out! Get out of the tunnel. The collider has been turned on!

Bad Scient. The protons are coming!! Everyone get out. Here they come...

Good Scient.: *(To audience, as he is about to run out.)* Sorry, but **you** have to stay...

Exp: Collider with people and LEDs (see App. A.28)

(The room goes dark. Two people in white LED suits come from either side of the lecture hall. They pass in the middle and at either end disappear again. On the next pass they collide in the middle. The white lights extinguish. Another person in a green LED suit rises and moves slowly before also his light extinguishes and two people in blue LED suits run up the two aisles of the auditorium.)

Caretaker: *(Spot light on Caretaker.)* Wow, that was amazing. I would like to see that again. How 'bout you? Maybe we can rewind that.

(Hear the sound of a tape rewinding. Caretaker “rewinds“ with his hand. The blue LED people (photons) return back down the aisles. Their lights extinguish as they meet and the green LED person lights up, slowly moving backwards. (You can hear the beeping sound of a van backing up.) Then he extinguishes and the two white LED people reverse to the sides of the stage.)

Caretaker: Okay, but now a bit slower.

(The Caretaker claps his hands and slowly the collision again proceeds forwards, this time the Caretaker explains what is happening.)

Caretaker: Here come our two protons in shining white hurtling down the LHC tunnel. In the center, in the middle of the detector they collide. On this rare occasion, they produce a big fat green Higgs boson. The Higgs lives only a very short time and then decays to two blue photons. And these fly through our detector and are thus observed. This is how the Higgs boson was discovered at the LHC.

Caretaker: So, our two heros have found the Higgs boson and have completed their quest. We hope you have enjoyed this journey ... I have. Now I have finished MY work, and I guess it is time to call it a day and head home. *(Picks up a black umbrella. Turns around, opens the umbrella and puts it over his shoulder. In gold writing on umbrella "The End", see Fig. 26. Slowly spins the umbrella as the spot light shrinks down to just the umbrella ... then extinguishes.*

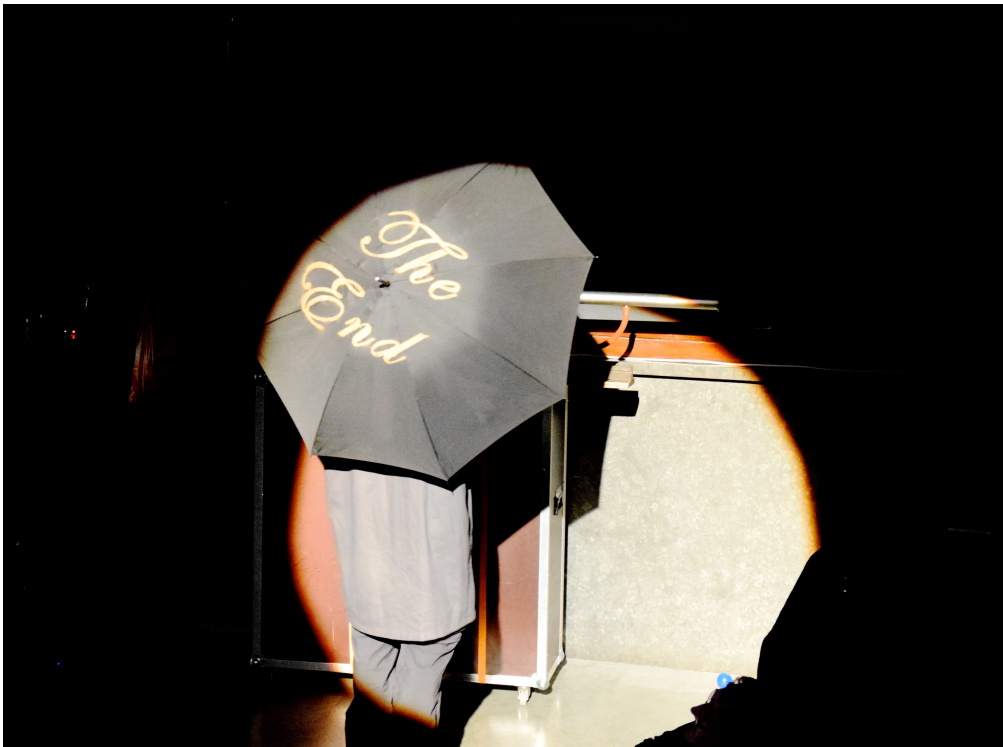

Figure 26: Closing scene with the Caretaker.

THE END

5 Conclusion

We have presented the details of a physics show we have developed on modern particle physics, including the Higgs boson. The show includes 28 live experiments performed and explained onstage.

Acknowledgements

We thank the SFB-TR CRC 110 *Symmetries and the Emergence of Structure in QCD* for extensive financial support, which made the trips to Oxford and London (2014) as well as to Padua and Trieste (2015) possible. The SFB furthermore supported a Physikshow trip to DESY, Hamburg in Spring, 2014. In the last fourteen years we have also received extensive financial and moral support from the Physikalisches Institut der Universität Bonn, including many work hours from Michael Kortmann and Sascha Heinz, as well as the use of the department workshops. We have also received over many years financial support from the other institutes in the Fachgruppe Physik und Astronomie der Universität Bonn: the HISKP, the IAP and the AIfA.

We would like to thank Katinka Ballmann, Doug Cowen, and Sidney Perkowitz for going over the entire manuscript.

From the beginning and over many years Patricia Zündorf has provided logistical support on all levels as well as never ending encouragement to the Bonn Physikshow. Until recently she was supported by Dagmar Faßbender, who is now retired. For several years now, and in particular for this show and our trips to Great Britain and Italy we have been extensively supported by Petra Weiß, who also handled most of the financial issues.

This show is based on two earlier Bonn particle physics shows, the first performed in 2004 and the second performed from 2008 to 2010. We have benefitted greatly from the experience gained in those shows and have retained quite a few experiments. We would like to thank the members of those shows for the enjoyable collaboration and the invaluable input they have given: Timo Altfelde, Katinka Ballmann, Markus Bernhardt, Nicki Bornhauser, Sebastian Fuss, Mathieu Gentile, Stefan Görs, Peter Henseler, Marc Hofmann, Walter Honerbach, Markus Jüngst, Alexander Karim, David Keitel, Michael Kobel, Claudia Koböke, Anna-Lisa Kofahl, Peter Kofahl, Karsten Koop, Rebecca Koop, Naëmi Leo, Christoph Luhn, Jessica Mende, Remer Meyer-Fennekohl, Nico Möser, Cornelia Monzel, Martin Niestroj, Tim Odenthal, Stefan Patzelt, Ludmila Piters-Hofmann, Marc Prinz, Jana Puschra, Christoph Rosenbaum, Iris Rottländer, Melanie Schmitz, Jan Schumacher, Markus Schumacher, Duc Bao Ta, Sofia Terhalle, Tobias Troost, Andreas Valder, Judith Wild, Karina Williams, and Daniela Wuttke.

In the 14 years of the “standard” (non-particle physics) Physikshow over two hundred students have participated. It is not possible to mention all of them here. I would just like to mention a few more beyond those listed above, who have been decisive for the development of the show: Jana Bürgers, Robert Geisselbrecht, Dominick Klaes, Branislav Poletanovic, Andrea Raccanelli, Tobias Strehlau, and Alice Yeo.

For this show, Dagmar Faßbender (Bonn University) sewed the LED-light suits. The wooden scattering experiment was designed by one of us (MKo) and built by W. Lenz and him.

We thank Karina Kortmann for designing several of the Physikshow on-tour T-shirts.

We would like to thank Bonn University for their support over the years. Andreas Archut and the Presse-Abteilung have been extremely helpful in promoting the show. We thank the University for trusting us and getting us the best gig ever, at the Deutschlandfest on the Bonner Münsterplatz in front of over 10,000 people in 2011. And we are very grateful for receiving the Alumni Prize of Bonn University in 2006.

We would like to thank Andrea Niehaus and the crew at the Deutsche Museum, Bonn, Bad Godesberg, for initially believing in us and giving us our first opportunity outside of Bonn University. They have been supporting us over the last 10 years. We also

thank them for hosting the premier of this show in German and in Germany. We thank Rainer Mählmann from the Deutsche Museum, München for many years of support and our first invitation outside of Bonn. Thank you also for trusting us despite a chaotic last rehearsal and a sleepless night.

We thank John Wheeler for inviting us to Oxford University and Sian Owen (Oxford University) for her superb support and organization in the many months leading up to and then also during our stay in Oxford, in March, 2014. We thank Daniela Treverigennari, as well as Marc, Luca and Giulio Taggert for their culinary and leisure-time (Freizeit) support during our stay in Oxford. We thank Jon Butterworth and Oli Usher (UCL London) for their extensive support leading up to and during our visit at UCL in London. In difficult circumstances they made things work. Thank you also to Anna and Jay Watson for their hospitality during our visit in London.

We thank Francesca Soramel and Fabio Zwirner (University of Padua) for the invitation to Padua and the support for our trip. We thank them for their wonderful hospitality and the great atmosphere in their lecture hall. It has to be said: for us, this was our best show ever! We thank Giampaolo Mistura for all his local organizational efforts. We thank Sara Magrin and Roberto Temporin for all their technical support in the Padua lecture hall and their very warm hospitality. We thank the Baccolinis for regional support. Scarpone!

We thank Fernando Quevedo (ICTP Trieste) for inviting us to Trieste, the support for our trip, the warm hospitality and the housing right on the beach! We thank Joe Niemela and the local organization for their support and for filling the large lecture hall!

We thank Volker Lannert for all the great photos he has taken at Physikshow events over the years and for always making them available to us.

We thank Daniel Class and Don Lincoln for allowing us to use the image in Fig. 62.

We thank Nathalie Burwick for composing the music, which accompanies the time machine during the shows.

A Technical Details of Demonstration Experiments in the Show

In this appendix we summarize the details of the various experiments presented in the show. They are given in the order they appear there. Where possible, we include a brief history of the experiment, and its relevance to (particle) physics. We then describe the materials employed and give the technical specifications needed to build the respective apparatus. Next we describe the typical presentation in the show. The context in the story line and the actual wording of the explanation during the show is given in the text in Section 4. We conclude the description of each experiment with a discussion of relevant safety issues.

Before discussing the individual experiments we give some more general pointers which are pertinent to all the experiments.

A.1 Presentation technique

In general when we present an experiment in the Bonn physics show, we first describe the setup in detail. It takes the audience some time to understand what they are seeing, and in most cases they can not appreciate the results, unless they have some familiarity with the “initial conditions.” Therefore, before performing the experiment, we guide

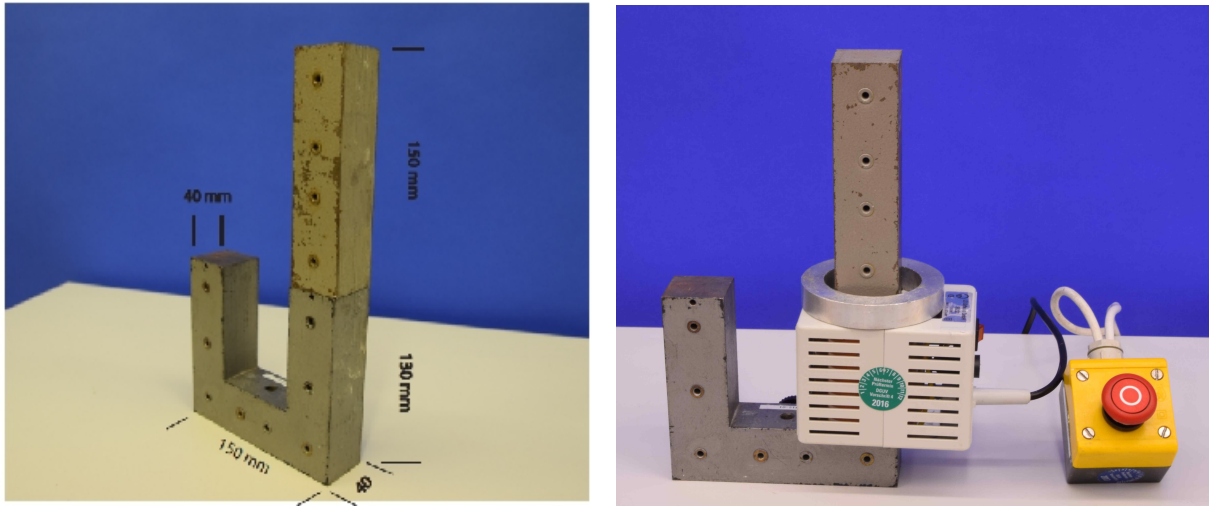

Figure 27: The jumping ring experiment, which is not part of this show. It is discussed for illustrative purposes. As can be seen on the left, we have a symmetric U-shaped iron yoke. On one arm we place a 150 mm extension. On this we place a coil with 500 windings. The coil is connected to the mains power (240 V, 50 Hz) via the red button switch. We often have an audience member hit the switch.

them through the various parts of the apparatus and explain how they are connected. In the process we make sure not to give away the main effect, the punch line of the experiment, so-to-speak.

In order to make this a bit clearer, we consider an example-experiment, which we often perform. This is on Lenz's law, also known as the jumping ring. The setup is shown in Fig. 27. Instead of just hitting the red button and watching the ring fly up, we first draw the audience's attention to the iron yoke, and then the coil, which is placed on the extension of the yoke. It consists of 500 windings of copper wire; the maximum load is 2.5 A. The coil is hooked up via the red button to the main voltage supply, 240 V, 50 Hz, in Germany. Next, we place an aluminum ring (outer diameter: 90mm, inner diameter 60mm, 16mm thick) on the extended leg of the iron yoke. The dimensions of the iron yoke can be seen on the left in Fig. 27. It consists of lamination steel, which suppresses eddy currents.

When explaining the setup, we do not mention that the ring could fly upwards, many people do not know this. The surprise is a main effect of this experiment. We then have an audience member, typically a child, come forward and on the count of three, the child hits the red button launching the ring upwards. Here we often play a sound effect of disappointment, as the ring does not fly very high, maybe about 1 m. We then repeat the experiment with a ring which has been cooled for a long time in liquid nitrogen. Depending on hitting the right phase, this ring can fly 3 meters into the air, significantly higher than for example in [30].

If there is additional time, it is also instructive to use a ring which has a small slit in it, which one could even hide from the audience. Since now no circular current can flow in the ring, it does not jump and you can just hear the coil vibrate. To make it clear that there is a slit, we insert a white sheet of paper. A further variation is to use a closed iron ring of the same geometric dimensions. This ring also does not jump, as the coil forms an electromagnet which attracts the iron ring stronger than the repulsion from Lenz's law. To demonstrate that it is indeed iron we use a permanent magnet.

The essential point being: each experiment is different, but it is important to give the audience time to absorb what they are seeing, and to guide them through the setup *prior* to performing the experiment. And whatever astonishing feature the experiment may hold, should not be revealed before hand.

A.2 Fire Tornado

In our show, the fire tornado is symbolic of a camp fire, and is presented in the prologue, Sect. 4.1. It has nothing to do with particle physics, and is thus not explained there, although usually we do explain it.

The fire tornado is a fairly well known experiment, with many example videos publicly available, *e.g.* on YouTube [31]. It can be used for entertaining purposes, as we do in this show, as well as for demonstrating angular momentum conservation, temperature dependence of the density of air, the stack effect, and the different colours emitted by alkali metals when burning. Fire tornadoes require a fire, in our case provided by igniting safety paste in a large metal dish. The latter is placed in the center of a rotating platform. The hot air from the fire rises and draws in fresh air from the side. If this air is set in rotation, conservation of angular momentum leads to a higher angular velocity, as the air approaches the fire, at smaller radii, leading to the full tornado. This is similar to a figure skater drawing her/his arms in as she/he rotates.

Fire tornados can occur naturally in intense wild fires. An example has been filmed in Australia [32]. Fire tornados can also be created, a nice version is where the air is set in rotation by several box fans at fixed distance around a camp fire, but blowing at an angle to the radial direction [33]. This is not practical for an indoor show. We discuss here a safer and easier to repeat setup, using a vertical rotating cylinder, as can be seen for example in [31].

A.2.1 History

We do not know who devised the first fire tornado for demonstration purposes, but there is a variety of instructions to build mostly smaller devices on the internet.

A.2.2 Materials and Technical Details

The experiment is shown in Fig. 28. It requires a thin sheet of metal which is rolled into a cylinder. We use a 2 m high cylinder with a 63 cm diameter. The metal sheet is 2 mm thick. The metal sheet must be perforated with holes, to allow air flow, and also for visibility of the fire tornado inside the cylinder. Our metal sheet has 5 mm x 5 mm size holes. The cylinder is placed on a well-oiled metallic turntable, and fixed with braces, so it can not tip over. Inside the turntable we have a fire-proof, pan shaped vessel. We place safety burning gel (or paste) inside the vessel. There is an additional larger hole at the bottom of the side of the cylinder, through which we can ignite the gel with a long match.

A.2.3 Presentation

The paste is set on fire and the rather small flame is shown to the audience. Some appropriate music possibly with a spinning and/or fire context is played, while the turntable is spun. Even with low spinning velocities the air starts rotating and a tornado builds up quickly within the cylinder. This is one of the few experiments where we do



Figure 28: Fire tornado in our 2 m high rotating cage.

not explain the setup beforehand, as it is pretty much self-explanatory. We usually explain the effect afterwards, however not in the particle physics show. Here it was just supposed to represent a camp fire by the Rhine in Bonn. It is often nice to dim the lights during this experiment.

One can add alkali metals to the paste which give the flame nice colors. In the particle physics show we did not do this.

A.2.4 Safety

If handled properly the fire tornado is a safe device, however there are a few things to take into account. First, only safety gel/paste should be used as a burning material. The fire can then not spread easily if the device falls over by accident. The floor below the device and within at least one meter radius should be fireproof. The amount of burning gel/paste should be chosen to allow the fire to burn only as long as needed for the demonstration. When filling the vessel, you should have in mind that while spinning, the burning gel (paste) will accumulate at the edge. Many lecture halls require the completion of a safety form when performing any experiment with an open flame, such as the fire tornado. Thus also when traveling to a new location, make sure all the local safety requirements are fulfilled. You might also need to turn off the smoke alarm during this experiment. This should also be done in accordance with your local safety code.

A.3 Lord Rayleigh's Oil Drop Experiment

The oil drop experiment, shown in Fig. 29, is simple to execute but returns a surprisingly accurate measure for the thickness of an oil molecule and therefore the scale of the size of the atom.

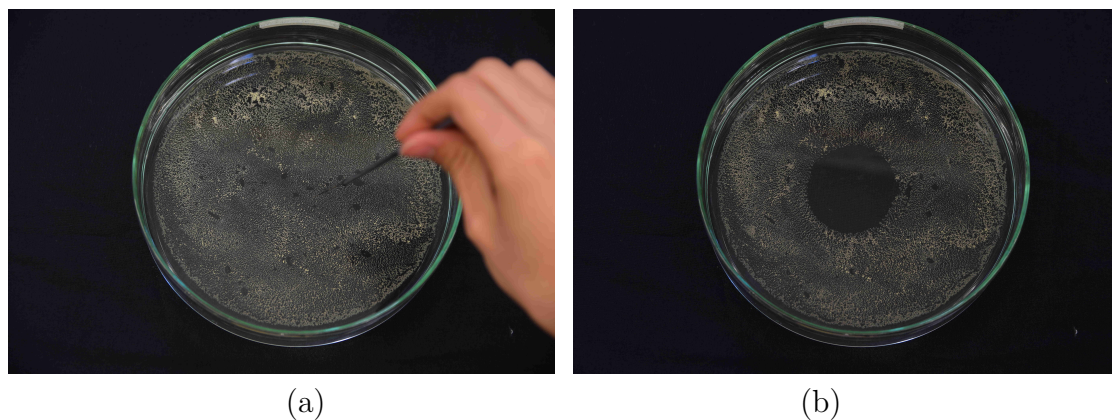

Figure 29: Lord Rayleigh's Oil Drop Experiment. (a) Petri dish with the lycopodium powder spread on the surface. The needle is just above the surface of the water. (b) After the drop of a mixture of oil and ethanol is placed in the center, it displaces the spores and a circular oil film is clearly visible.

A.3.1 History

The first usage of this experiment to measure the thickness of oil was performed by Lord Rayleigh in 1890, but the experiment itself dates back to 1774 with Benjamin Franklin's attempts to describe the spontaneous spreading of oil molecules [34]. In his experiments Lord Rayleigh found the thickness to be 16×10^{-8} cm [35], although by implementing a cleansing technique on the surface another scientist, Agnes Pockels, obtained an improved value of 13×10^{-8} cm only a few years later [36, 35]. This latter measurement is accurate to two significant figures according to more modern measurements.

A.3.2 Materials

The experiment, as shown in Fig. 29, requires water, a Petri dish, some oil, which is in fact a mixture of ethanol and oil acid in the proportion 1:2000. Furthermore we use a fine tipped needle or extremely precise graduated pipette, lycopodium powder⁵ and some form of dispenser for the powder. Ours consists of a beaker covered by a taught cloth with a few small holes which is essentially a very fine shaker. The presentation of the experiment works best when placed on an overhead projector.

A.3.3 Presentation and Technical Details

For the experiment, we fill the Petri dish about half way with water. We shake out enough lycopodium powder to cover the entire water surface, see Fig. 29(a). With the needle we extract a small drop of the oil and ethanol mixture from the bottle and carefully apply it to the center of the Petri dish. Here a highly accurate graduated

⁵This can be purchased online, see for example: www.zooscape.com/cgi-bin/maitred/GreenCanyon/questp511741/r11.

pipette can also be used. Touch the needle to the surface of the water as close to the center as possible. The powder will be pushed aside by the oil droplet, allowing us to measure the area of the thin surface formed. It's important that the oil drop used is small enough that the Petri dish surface is only partially covered by the oil film, as shown in Fig. 29 (b).

In the show, we place the Petri dish on an overhead projector so that it can be seen by the entire audience. We also assume the volume of the oil drop is known, and we do not actually measure the area of the oil surface because it would take too long. We instead just present the relevant equation on a slide:

$$\text{oil drop thickness} = \frac{\text{oil drop volume}}{\text{measured oil film surface area}}, \quad (1)$$

and give the value of the resulting thickness, which we interpret as being the size of an oil molecule. This is the only mathematical equation we present in the show.

While we don't address this in the show, the fact that the film is one molecule thick requires only some basic chemistry to explain. Oil molecules have a polar head and non polar tail which align so that the polar head points towards the water and the non-polar tail points away. This means that the molecules will orient themselves so that their entire length runs perpendicular to the surface of the water, see Fig. 30. Since we determine the thickness of the film we thus measure here the size of the entire molecule: polar head plus tail.

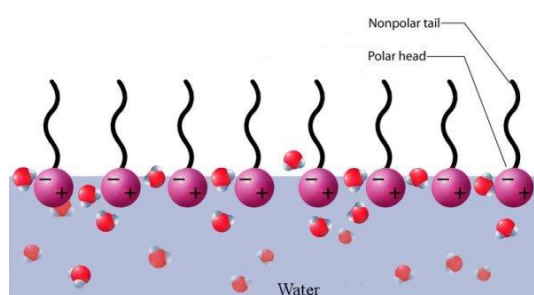
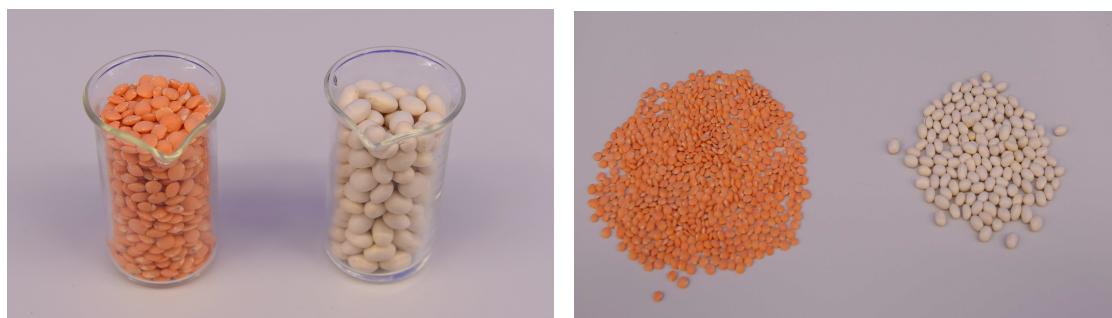

Figure 30: A visual depiction of the alignment of the molecules [37].

A.3.4 Extensions

Given more time it is instructive to add a further experiment, as an analogy. One of us (HKD) often uses this in public lectures on atoms. We fill one small glass with lentils and one identical glass with beans, so there is an equal volume of both. Use for example red lentils, and white beans, see Fig. 31 (a). We pour both of them out to form two separate circles in a single layer of lentils/beans, see Fig. 31 (b). Because lentils have a much smaller diameter they form a much larger surface area than the beans. This quick demonstration gives an intuitive confirmation of Eq. (1).



(a) Lentils and beans in equal sized beakers. (b) Lentils and beans spilt on table.

Figure 31: Simple analogy experiment with lentils and white beans.



Figure 32: Wooden scattering experiment. The steel balls roll down the incline and hit the central target, here a triangular piece of wood. The target can be replaced by other shapes. The outside ring is lowered and divided into 18 equal-sized pockets, of scattering angles $\Delta\phi = 20^\circ$, where the steel balls are collected and counted.

A.3.5 Safety

The needle and the oil-ethanol mixture should be kept safely away from any children in the audience.

A.4 Wooden Scattering Experiment

Our wooden scattering experiment is shown in Fig. 32. It is a simple demonstration of scattering steel balls off of a central target. The shape of the target can be varied.

A.4.1 History

Certainly over the years many similar demonstration experiments have been built. We were inspired by a similar design at DESY, Hamburg, seen by one of us (EP), some years ago [38]. It shows that iron balls (as beam particles) scattered off of targets of different shapes yield different distributions. A second improved experimental setup was built at DESY [39] for the exhibitions “Particle Zoo” and the touring exhibition on the LHC, “Weltmaschine” [26]. The DESY experiment was rectangular. We modified the design to be circular, as shown in Fig. 32. It was built by one of us (MKo), together with W. Lenz, the cabinet maker in the Physikalische Institut, Bonn.

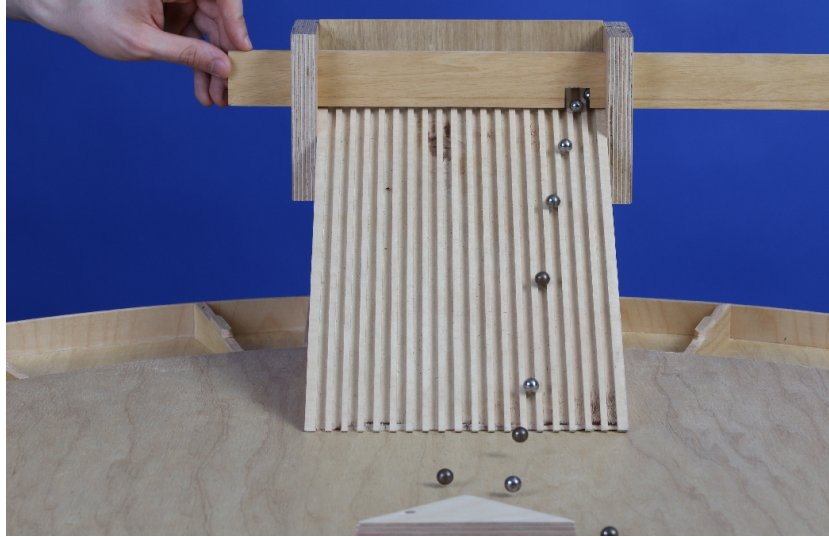

Figure 33: The mechanism for releasing the steel balls down the ramp. This ensures that the balls do not scatter off of each other. In the back we have a loading mechanism, so that while we release one set of steel balls, we can refill a second set, just behind.

A.4.2 Materials and Technical Details

The experiment is built in 3 parts:

1. The main part of the experiment consists of a circular board with an outer diameter of 110 cm equipped with 18 lowered pockets for collecting the balls after they have scattered (or not) off of the central target. The pocket size corresponds to a scattering angle range of $\Delta\phi = 20^\circ$. The upper board has a diameter of 89 cm. The pockets are lowered by 12 mm and separated by 25 mm high dividers. The dividers should be thin, to have well defined pockets. The lower circular board is bounded by a 25 mm high wooden band.

2. On one side of the circular experiment we have a ramp with 19 small grooves for guiding 19 balls in straight lines down the ramp. The grooves have been cut with a circular (buzz) saw into a multiplex wooden board. The ramp is 20 cm wide and about 20 cm high. The ramp has a sliding board with a small hole, to allow the balls to descend the ramp individually, as shown in Fig 33. This avoids scattering between the steel balls. Behind the sliding board, we have a hinged board, as shown in Fig. 34. Behind this hinged board we can store 19 further balls. After the first 19 have been released down the ramp, we can swing the hinged board to reload the balls for scattering. While the second set is released, we can reload the hinged board, making it possible to do a multiple set of scatterings rapidly during a show. To speed up the refill, we prepare several containers with the exact number of balls beforehand. The balls are made of chromium-plated steel and have a diameter of 10 mm.

3. In the center of the circular board we fix targets of various shapes and sizes. Pegs in the targets slot into holes in the top board. In the show we use a circular target with a diameter of 12 cm and a triangular shaped target with long edge perpendicular to the beam direction of 12.8 cm. The geometric height of the triangle is 6 cm. The targets have a thickness of 11 mm.



Figure 34: The reloading mechanism. The board holding the upper row of steel balls is easily rotated, releasing all balls to the lower level.

A.4.3 Presentation

Before starting the experiment, it is important that it is setup exactly horizontally. In the show we do three runs of 19 balls for the circular target, and then again for the triangular target. As the target is not as wide as the ramp quite a few balls pass the target unscattered and enter the two forward direction pockets. For the circular target the remaining balls are distributed roughly evenly over the other pockets. For the triangular shaped target there is an accumulation in two directions. This can be seen after the three respective runs. However, in order to emphasize the point, we also show two photos of the results for multiple runs on the circular and triangular target, respectively, see Fig. 35. Between the runs on the two targets, the Caretaker appears on the scene and collects the scattered steel balls with a magnet, which then vanish in his overcoat pocket.

A.4.4 Safety

There is no obvious safety risk in running the experiment. Small children in the audience should not be allowed to get the steel balls, for example after the show, as they might swallow them.

A.5 Cathode Ray and Helmholtz Coils Experiment

The Helmholtz coils are an extension of the cathode ray tube experiment regularly presented at the high school level. In German high schools the entire setup, as presented here, is often employed.

A.5.1 History

We briefly recount some aspects of the history of the cathode ray tube, especially since some of the important developments occurred in Bonn [40, 41]. The earliest relative of the cathode ray tube was the gas discharge tube, invented in 1838 by Michael Faraday.



Figure 35: The result of several runs of our scattering experiment, on the left with a circular target, and on the right with a triangular target.

It was similar in construction, but lacked sufficiently low pressure and more modern electron emission techniques. Thus early experiments gave a glowing cloud instead of a collimated beam. In 1858 in Bonn, Johann Heinrich Wilhelm Geissler, a glass blower, invented both the mercury pump and the metal–glass seal, creating a superior vacuum. Employing these advances, he developed the Geissler tubes. These were the first examples of what is traditionally used in the classroom today as a cathode ray tube. The Geissler tubes are evacuated and filled with small quantities of neon or hydrogen gas to form a colorful light beam in the electron’s path. The first major investigations with the tubes were performed by Julius Plücker in Bonn [42]. In the 1870’s William Crookes developed the Crookes Tube, but his technology was focused more on image projection, not visualization of the electron beam.

The cathode ray tube is set in the middle of the Helmholtz coils. The latter consists of two coils, separated a distance $d = R$, where R is the radius of the coil. This generates a nearly homogeneous magnetic field inside the cathode ray tube.

We have not been able to determine, whether Helmholtz actually invented the Helmholtz coils. Incidentally, Helmholtz was a professor of physiology in Bonn from 1851 to 1858.

A.5.2 Materials

The Helmholtz coils together with the cathode ray tube used in the show are manufactured by Leybold Didactic for educational purposes [43]. Our setup is shown in Fig. 36. The central part consists of a glass tube with a large spherical mid–section. The glass tube is evacuated and then filled with a small amount of hydrogen gas. The final pressure in the tube is 1.33×10^{-5} bars. The electron gun in the central sphere shoots the electrons vertically upward. Around the glass vessel are two large coils in the same plane as the electron beam. They produce an approximately homogeneous magnetic field in the glass sphere. If the magnetic field is not perpendicular to the electron beam, the electron forms a spiral path.

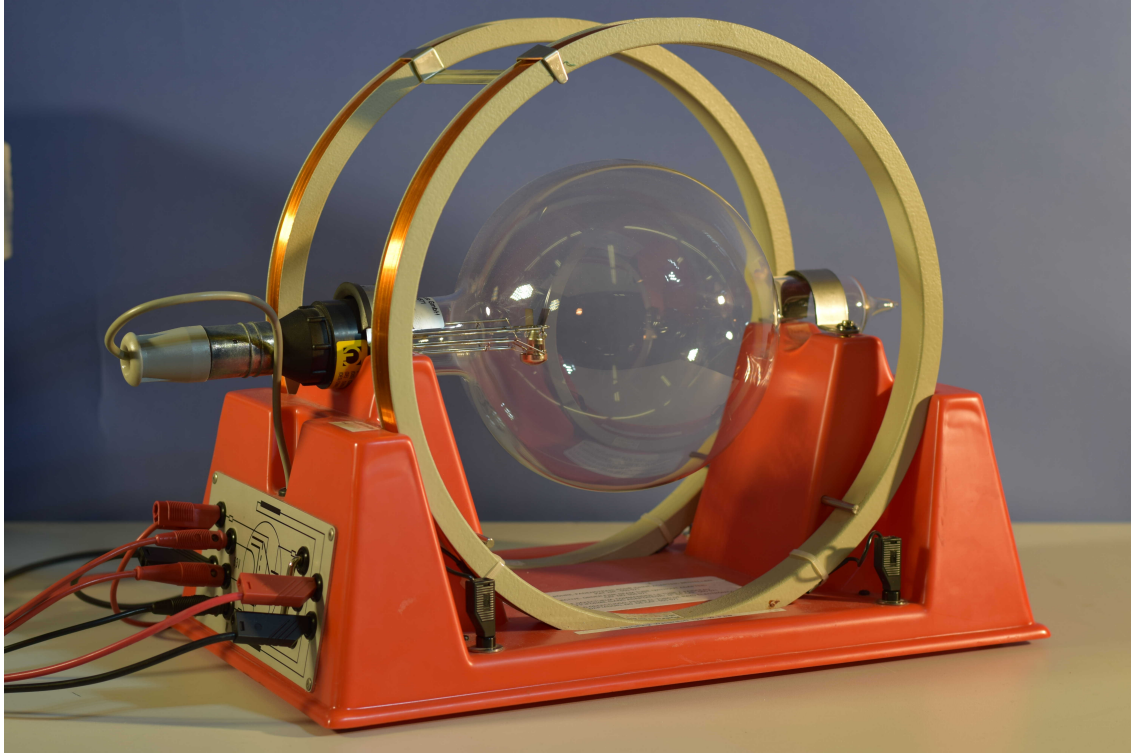

Figure 36: The Helmholtz coils with the glass tube and electron beam emitter.

A.5.3 Technical Details

We typically use an accelerating voltage for the electron gun of 200 V. The current for the Helmholtz coils is around 1 A. The resulting magnetic field is about 0.68 mT, which gives an electron beam orbit radius of about 7 cm.

While this is not done during the show, the apparatus can be used to measure the electric charge to mass ratio of the electron. Setting the centripetal force equal to the Lorentz force one has

$$\frac{m_e v_e^2}{r} = q_e v_e B, \quad (2)$$

where m_e , v_e , q_e are the mass, the speed and the charge of the electron, respectively, B is the magnetic field and r is the electron orbit radius. Using the fact that the kinetic energy of the electron $\frac{1}{2}m_e v_e^2 = q_e U$, where U is the applied accelerating voltage, we can solve for the electron charge over mass ratio

$$\frac{q_e}{m_e} = \frac{2U}{B^2 r^2}. \quad (3)$$

Inserting our values, we obtain $\frac{q_e}{m_e} = 1.8 \times 10^{11} \frac{\text{C}}{\text{kg}}$ which is close to the known value.

A.5.4 Presentation

In the show, we first explain the details of the setup with the camera image projected onto the screen. At this stage the magnetic field is zero, thus when we dim the lights, the blue glow of the electron beam points vertically upwards. We then play suspenseful music, for example the theme from the film *Mission Impossible*, as we adjust the magnetic field. The electron beam forms a circle, which varies in size, see Fig. 37. The

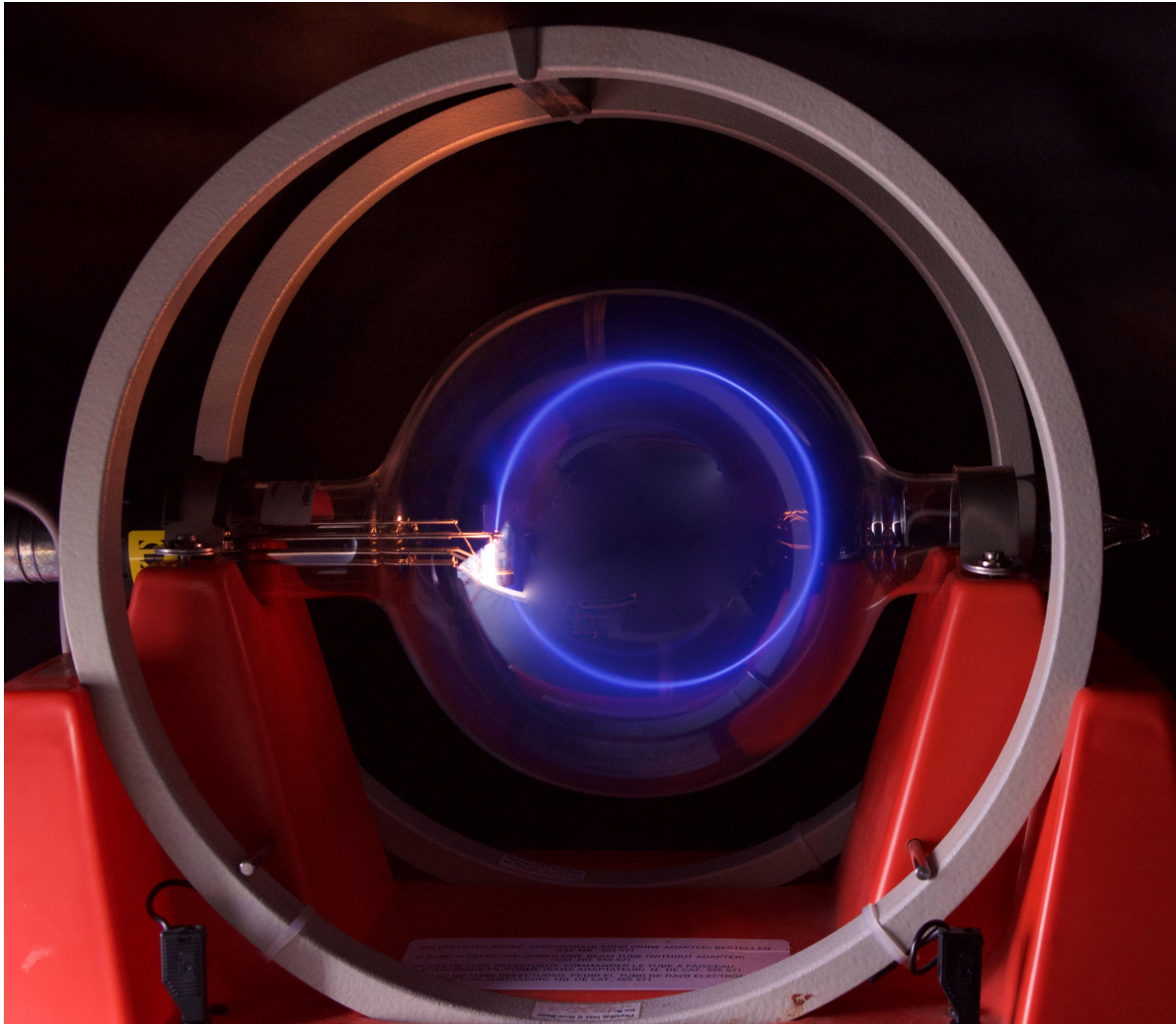

Figure 37: The Helmholtz coils: the circular blue glow shows the path of the electrons interacting with the hydrogen gas.

essential point is that the audience here gets to “see” an elementary particle for the first time, via the interaction with the gas.

A.5.5 Safety

Follow the safety instructions of the electrical equipment. As there is very low pressure in the glass tube, one should be careful not to break it, *e.g.* during transport.

A.6 A Simple Charged Particle Detector: Radioactive Decay and Jacob’s Ladder

This is a nice and simple experiment to show how ionizing radiation, or otherwise invisible particles, can be detected in a way directly observable by a live audience. The discharges are visually spectacular close up, but the small size of the experiment requires a projector for it to be appreciated in a large lecture hall. care must be taken, to only use radioactive sources conforming with all safety regulations.

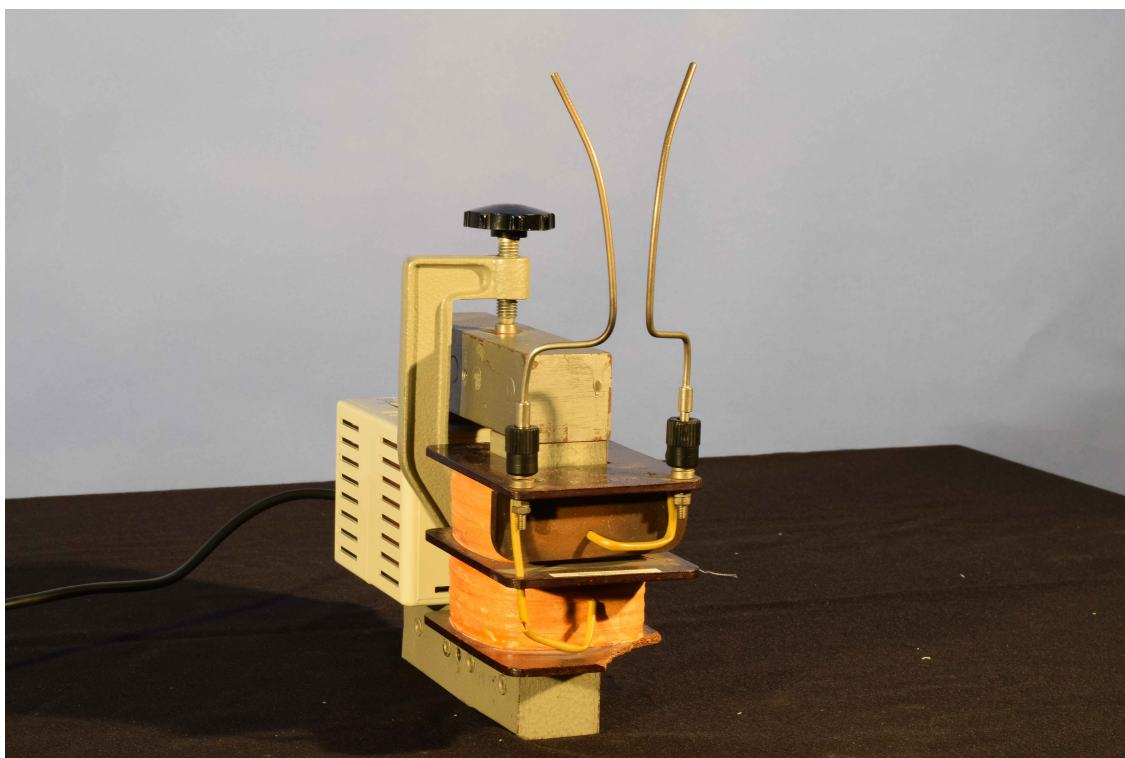

Figure 38: Our Jacob's Ladder

A.6.1 History

The exact history of the Jacob's ladder experiment is difficult to trace. In principle, the version we use is a redesigned Geiger counter which allows for a more readily observable reaction to the ionizing particles. The first Geiger counter was invented in 1911 by Hans Geiger as a means of counting radioactive alpha particles. In 1925 Geiger and Walther Müller, enhanced the device, so that it could detect many forms of ionizing radiation [44]. If an individual has been accredited with the first implementation of the Jacob's ladder specifically for the detection of ionizing radiation, it is not well documented.

A.6.2 Materials

The setup consists of a primary coil with 500 windings and a secondary coil of 23,000 windings. They are connected by a closed rectangular iron yoke made of lamination steel, as in App. A.1. This yields an amplification factor of 46. The primary coil is connected to the main voltage of 220 V via a variable transformer. Thus the output AC voltage of the primary coil can be varied between 0 and 220 V. The secondary coil is connected to two bent wires forming the "Jacob's Ladder" arrangement, as shown in Fig. 38. The wires are 3 mm thick. At the closest point at the bottom, we set the gap to about 7 mm, when detecting the ionizing radiation. The gap can be larger if one uses a match to light the spark. In the show we fix it to the narrower value as we perform both of these experiments immediately in sequence.

It is essential to be able to vary the gap voltage continuously. If it is too low, no spark discharge will occur. If it is too high there are serial discharges unrelated to the ionization provided by the agent. We set the voltage as high as possible without getting natural discharges.

We use a long match to first trigger the discharge. We then used an Am²⁴¹ source,

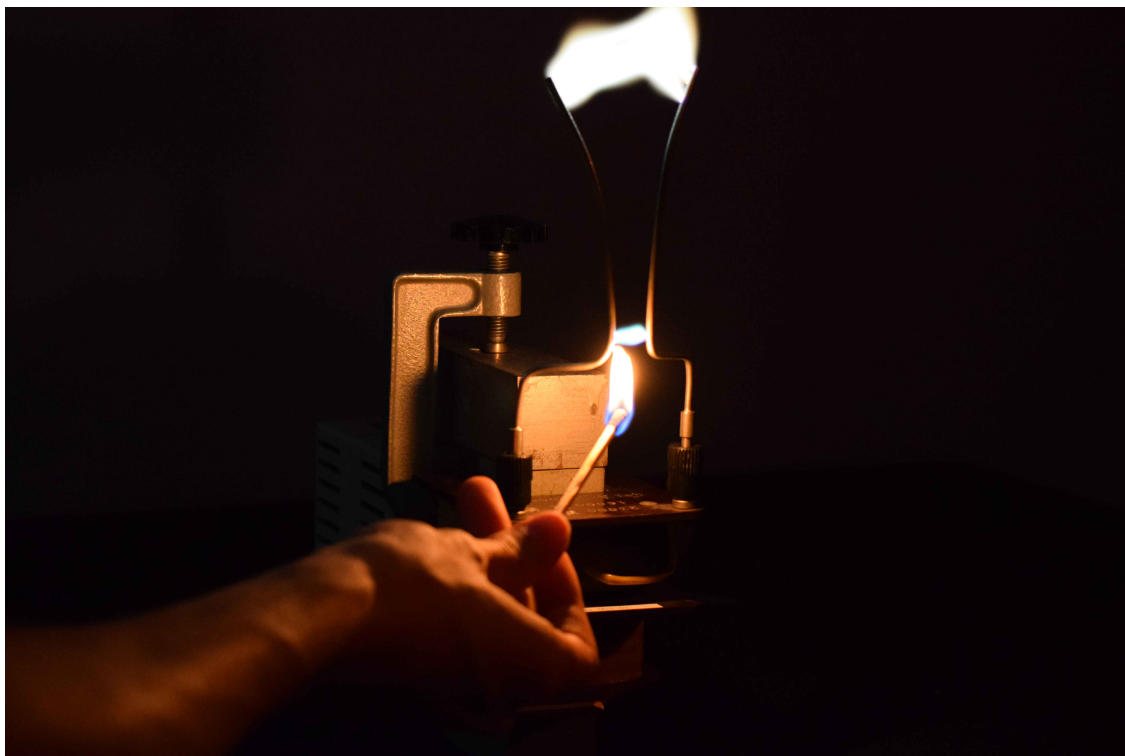

Figure 39: The climbing spark effect with a match as the initial ionizing source. Here the input potential was around 100 V, corresponding to about 4,600 V at the gap, and the two bars were about 1.5 cm apart.

which is an α -emitter, with a radioactivity of 340 kBq. Unfortunately, this source cannot be transported according to current law. We thus show a film in the show.

A.6.3 Presentation

We first turn on the voltage to a level below where natural discharge occurs. Then we light a match and hold it just below the gap at the bottom between the two bars, see Fig. 39. The gas in the flame of the match is ionized, meaning it forms a plasma. This has a much higher conductivity than the air and we get a spark discharge. Because the gap is smaller at the bottom the spark starts there. The spark itself is now a plasma and is hot. The plasma rises, and with it so does the path of least resistance for the electrons. This is the observed rising arc. The wires get wider towards the top and at some point the arc can not be maintained. In Fig. 39 one can see the lower spark ignited after the upper one.

The match is a good way of opening the experiment since it provides a visible cause to the ionization of the air, and the audience is familiar with a match⁶.

Now we repeat the same process with our radioactive source to demonstrate the ionization of the air by the otherwise invisible particles emitted in radioactive decay. The voltage must be increased to 200 V. Our recommendation is that beforehand the presenter should play with the variable transformer to get an idea for what voltage is appropriate for the two stages of the experiment. This will depend on the humidity, so

⁶There are several experiments one can perform to show that the flame forms a plasma. For example putting a lit candle between two capacitor plates. When the plates are charged the flame tilts to one side. Unfortunately, there is no time for this in our show.



Figure 40: The Jacob's Ladder activated here by a radioactive Am^{241} source. With a radioactivity of 340 kBq the source required a 200 V potential and 5 mm of separation between the bars. We are not allowed to transport such a strong source.

the best approach is to test the values the day of the experiment. Note that during tests the metal rods heat up, lowering the required natural discharge voltage.

The ionizing agents are now the highly energetic particles emitted by our source. In the photo, see Fig. 40, we use an Am^{241} source. This triggers the discharge correlated with the approach of the source to the gap. We thus have a simple charged particle detector, for everybody to observe live.

The radioactivity safety laws allow us to use this source in the lecture hall onstage. However, the European transportation laws for radioactivity are stricter, meaning that the source is not legal for us to transport. In Oxford and Padua we therefore used a weaker source, which is legal to transport, but for which it is somewhat trickier to trigger the sparks.

In the remainder of the show we use a Geiger counter connected to a loudspeaker. It is more abstract, but still quite immediate, and the audience now hopefully understands the underlying principle.

A.6.4 Safety

This experiment requires caution on several levels. The main concern is that we are applying thousands of volts across the gap which is enough to cause physical harm. All audience members should be kept at a distance from the experiment, and the presenter must take care not to touch the metal bars while he uses both of the agents. Furthermore, after using the apparatus, the power supply to the Jacob's Ladder should be turned off and disconnected. It's common for audience members to approach the stage during an intermission or after the show, and we want to assure that the device presents no danger.

The use of radioactive sources requires caution and the strict adherence to the safety rules. Three of us, HKD, MKo and EP, have participated in the required training

program. EP and HKD have also participated in the training program for transport of radioactive material. At any moment during the show or on our travels, one of the above is always responsible for the radioactive materials. It is also his responsibility to lock the sources away as soon as they are finished being used in the show.

A.7 Cloud Chamber

This experiment we use is built and sold by PHYWE. It is shown in Fig.41. For more information on this specific chamber see the website [45].



Figure 41: The PHYWE cloud chamber. The upper black part with the glass casing contains the actual chamber. Underneath is the electronics and the refrigeration unit. The plastic container on the right holds the 2-propanol. The wooden box is on wheels for easy transport. It also raises the chamber to a height easily visible for adults.

A.7.1 History

The cloud chamber was invented by the Scottish physicist Charles Thomson Rees Wilson (1869-1959), in 1911 [46], therefore it is also called the Wilson chamber. For this work, Wilson received the Nobel prize in physics in 1927, together with Arthur Compton [47].

A cloud chamber contains a supersaturated vapor. When high energy charged particles pass through the cloud chamber they ionize molecules in the gas along their path. In the supersaturated layer, these ions then act as seeds, where the vapor condenses, forming “contrail” like features, which are easily visible with proper lighting. In the original cloud chamber the supersaturation was achieved by expanding the chamber. Our apparatus is a diffusion cloud chamber, as invented by Langsdorf in 1936-37 [48], which allows for continuous operation [49]. Here the bottom side of the chamber is cooled well below freezing, in our case about -32°C . A small distance above the cold lower edge a supersaturated region develops.

Historically the cloud chamber was very important in particle physics. It was essential for the discovery of the positron by Anderson in 1933 [50], the muon by Neddermeyer and Anderson [51], and Street and Stevenson [52] in 1937, as well as the kaon, discovered by Leprince-Ringuet and L’Heritier [53], and Rochester and Butler [54] in the 1940s. This is thus a true particle physics experiment, which can be incorporated into a show.

A.7.2 Materials and Technical Details

We use a comercial PHYWE cloud chamber. To operate it only some 2-propanol is needed. It is possible to devise a simple diffusion cloud chamber with dry ice, as noted already in 1950 [55]. Dry ice has a temperature below -78.5°C . Documentation for construction using dry ice is also widely available on the internet, see for example [56].



Figure 42: A top view photo of the PHYWE cloud chamber, while in operation. An unusually long track can be seen here diagonally across the chamber, most likely a muon. In the lower left corner is also a thick track from a hadron, corresponding most likely to an alpha particle.

The PHYWE commercial cloud chamber we use has an enclosed volume of about 450 mm x 450 mm x 200 mm, covered by a glass construction. It weighs about 80 kg. The lower box contains the refrigeration unit. The 2-propanol evaporates from trays at the outer frame of the upper part in the glass housing. The entire apparatus must therefore stand on level ground. The 2-propanol is heated by a wire carrying an electrical current. This current can be varied, as can the flow of 2-propanol. In the bottom center there is a black metal plate cooled by the refrigeration unit. The chamber is

illuminated internally from the side. The 2-propanol vapor takes about 30 min to cool down sufficiently.

A.7.3 Presentation

The cooling unit of the cloud chamber is unfortunately fairly loud. We turn it on 40 min before needed and turn it off, just after it has been demonstrated.

For the show we place a small camera directly above the glass plate. The camera is connected to the projector via the control table. The lecture hall is darkened during the observation of the particles. If it is not dark enough, the cloud chamber and the camera should be covered with a black cloth.

The shape of the trails, as seen in Fig. 42, quite clearly indicates the nature of the particle passing through. They also happen sufficiently often for this to be explained live during the show. Very short thick tracks correspond to α particles. They are produced within the chamber from radioactive radon decays.⁷ Very thin tracks with an irregular path arise due to electrons or positrons, which mostly come from radioactive decays, as well. Apart from that we observe very thin long trails. These are due to muons (μ). They are (mostly secondary) particles produced by cosmic rays interacting with the atmosphere.

When we explain the cloud chamber with people standing immediately around, we explain the setup in detail, including the trays with the 2-propanol, the cooling unit etc. As an example of condensation, we often mention a cold glass outside in the summer, where water condenses on the outside. In the show presented here there is no time for this. Furthermore, we typically explain the origin of the particles, emphasize that they are constantly flying through everything and everybody, while we realise nothing. The cloud chamber enables us to see them. We mention the analogy of the particle tracks with airplane contrails and then discuss the observed particles in some detail. In previous shows, we also used photos of tracks in the cloud chamber to introduce new particles such as the strange quark.

A.7.4 Safety

The cloud chamber weighs about 80 kg. It has two sets of handles on the side and can be carried by two (strong) people. If at all possible, it should be wheeled around on the lower box and transported in an elevator between floors. Appropriate care must be taken, if a radioactive source is used with the cloud chamber, which we did not in this show. Otherwise this experiment is self enclosed and safe.

A.8 Beta $-$, and Beta $+$ Decay, Antimatter Live Onstage

In this experiment we demonstrate anti-matter live onstage, using β^- and β^+ emitters and a powerful magnet, see Fig. 43.

A.8.1 History

Radioactivity was discovered by Becquerel in 1896 [57]. He used a phosphorescent uranium salt as a source. However, the detector, a photographic plate, was wrapped in

⁷Rn²²² has a half-life of $\tau = 3.3$ days and is an α -emitter. Radon is a gas and occurs in daily life. It is the main source of the observed α -tracks.

thick black paper, which was most likely thick enough to absorb all of the α -rays. Thus the blackening of the photographic plate must have been due to the β -rays of the first daughter product in uranium decays: thorium-234. Becquerel could thus be considered the discoverer of β -rays. For a discussion of this history see for example [41].

In 1899, it was Rutherford who first showed that the “uranium rays” had two distinct components with different penetration strengths; he denoted them as α - and β -rays [58]. It took 10 years to establish that α -rays are in fact helium nuclei. Bragg and Kleeman were able to show in 1904, that the emitted α -rays had a fixed energy, a discrete spectrum [59]. This was thus also believed to be the case for β -rays. There were many inaccurate experiments using photographic plates, which seemingly confirmed this conjecture. However the photographic plates have a highly non-linear response to the β -rays, making a counting experiment difficult. It wasn’t until 1914 that Chadwick was able to show in Hans Geiger’s laboratory in Berlin, that the β^- -spectrum is continuous [60]. Remarkably the setup for his experiment is almost identical to our demonstration experiment, which we describe below. Chadwick had a β -emitter, containing lead (Pb-214) and bismuth (Bi-214), known respectively as radium B and C, at the time. The β -rays were bent by a strong magnetic field and detected, this is the decisive point, by a Geiger counter. In 1930, based on this experiment, Wolfgang Pauli [61] was able to postulate the neutrino, which was discovered in 1953 by Cowan and Reines [62]. Thus it took 18 years to establish the exact nature of β -rays. See [63] for an extensive description of the history of beta rays and the discovery of the neutrino.

As discussed in App. A.7, the positron, the anti-particle of the electron, was discovered by Anderson in cosmic rays in 1933 [50] using a cloud chamber. Nuclear β^+ -decay was first observed by Irène and Frédéric Joliot-Curie in 1934 after the α -irradiation of Al^{27} and B^{10} . We note that already in 1928 Dirac predicted the anti-particle of the electron [64]. It was the necessary consequence of combining the new quantum theory with special relativity.

A.8.2 Materials and Technical Details

We use two radioactive sources: Sr^{90} (strontium) and Ge^{68} (germanium). The Sr^{90} (strontium) source is a β^- emitter, releasing electrons at rate of 3.83 kBq. Sr^{90} β^- decays to Y^{90} (yttrium) with a β^- energy of about 550 keV. Y^{90} β^- decays to Zr^{90} with an energy of about 2.3 MeV. The Ge^{68} (germanium) source is a β^+ emitter, and has an activity of 1 kBq. The Ge^{68} undergoes electron capture to Ga^{68} (gallium). The gallium is the source of positrons. It decays yielding β^+ with an energy of about 1.9 MeV in the dominant decay mode. We use a strong horseshoe-shaped permanent magnet to bend the electrons (β^-) and positrons (β^+). The magnet has a permanent field strength of 210 mT, measured between the pole shoes. Thus the radii of curvature for our β^\pm are in the cm range. In the show, a hand-held Geiger counter with a loud speaker is used to detect the bent particles. The magnet is about 32 cm wide, 26 cm high and the gap is about 4 cm. It weighs about 35 kg.

A.8.3 Presentation

The setup is shown in Fig. 43. In presenting the experiment one person holds the β -source and the Geiger counter. They are initially held in line well above the magnet. A loud clicking sound can be heard. Slowly the source is lowered into the gap of the magnet between the pole shoes, while the detector is lowered in parallel, but outside



Figure 43: The horseshoe-shaped magnet. On the left, the silver, pen-like object is a beta emitter, on the right, in orange and black, is a Geiger counter.

of the magnet. With the source at the point of strongest magnetic field the clicking vanishes. The polarization of the magnet should be set up such that the electrons are bent down towards the base of the magnet. This is to later avoid extra effects from pair annihilation of the positrons on the base of the magnet. The Sr^{90} source is held fixed between the pole shoes, while the Geiger counter is first moved upwards and then downwards. The electrons are distinctly rediscovered having been bent downwards. Afterwards the experiment is repeated with the β^+ source, Ge^{68} , however now first “looking” downwards, where the electrons were, and then discovering the positrons above the magnet. This demonstrates the opposite charge.

A.8.4 Safety

Before using the sources onstage we inform the public of their nature and the required safety measures. The emission rate of both radioactive sources are below the limits for transport and public use. We always take care that the probes are moved to the setup very close to the time when the experiment is carried out, and are moved back into the radioactive safety box immediately after the experiment has been finished. It is very important not to drop the sources, and also to keep them away from the audience. Furthermore we take great care that the sources are never pointed at the audience.

A.9 Ripple Tank: Resolving an Object with Water Waves

This is an experiment to demonstrate the resolving power of a wave depending on its wavelength. We use a ripple tank illuminated through a glass bottom.

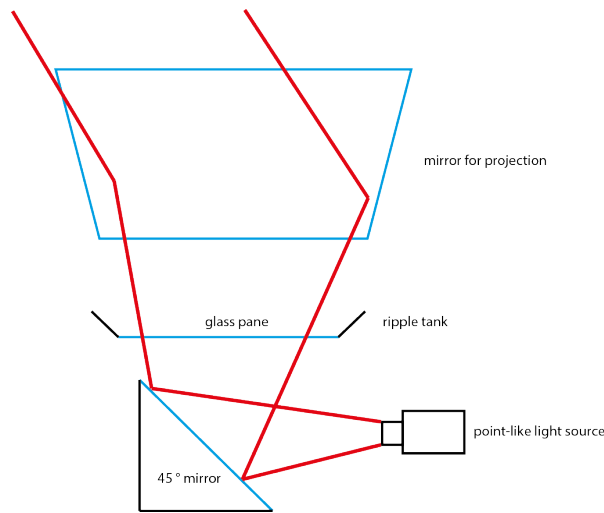

Figure 44: Schematic drawing of the setup for the ripple tank. On the right we have a point-like light source. A mirror deflects the light upwards to the ripple tank. The light enters the ripple tank through the glass plate bottom, is distorted by the water surface and then reaches a large mirror above the tank. This mirror redirects the light to a screen.

A.9.1 History

This is a standard experiment used in physics education to demonstrate the properties of waves, such as reflection, refraction, and diffraction. We use it here to demonstrate the resolving power of a water wave as a function of the size of the object and the wavelength of the water. This directly relates to ideas in particle accelerators, as we discuss below. A film we have made of this experiment has also been used by Jon Butterworth in his public talks about his book ‘Smashing Physics’ [3, 65].

A.9.2 Materials and Technical Details

In Fig. 44 we show a schematic drawing of our experiment, and in Fig. 45 a photo of the experiment. On the right we have a strong point-like white light source. A mirror deflects the light upwards to the ripple tank. The ripple tank has a few centimeters of water in it. The light enters the ripple tank through the glass plate bottom, is distorted by the pattern on the water surface and then reaches a large mirror above the tank. This mirror is roughly at a 45° angle and redirects the light to a screen⁸. Everything is mounted on a wheeled cart, and is thus easily wheeled on- and offstage.

On one side of the ripple tank is a straight bar dipper, see Fig. 45, which is connected to a motor, with adjustable frequency. When the motor is started plane waves travel across the full width of the tank and are clearly visible on the screen.

We also employ two cylindrical objects, with differing diameter: 2.5 cm and 5.5 cm. They are inserted vertically into the water.

A.9.3 Presentation

We briefly explain the setup. We then darken the auditorium and turn the wave generator on. The waves are clearly visible on the screen and the audience has an intuitive

⁸Thus a second screen is helpful during the show.

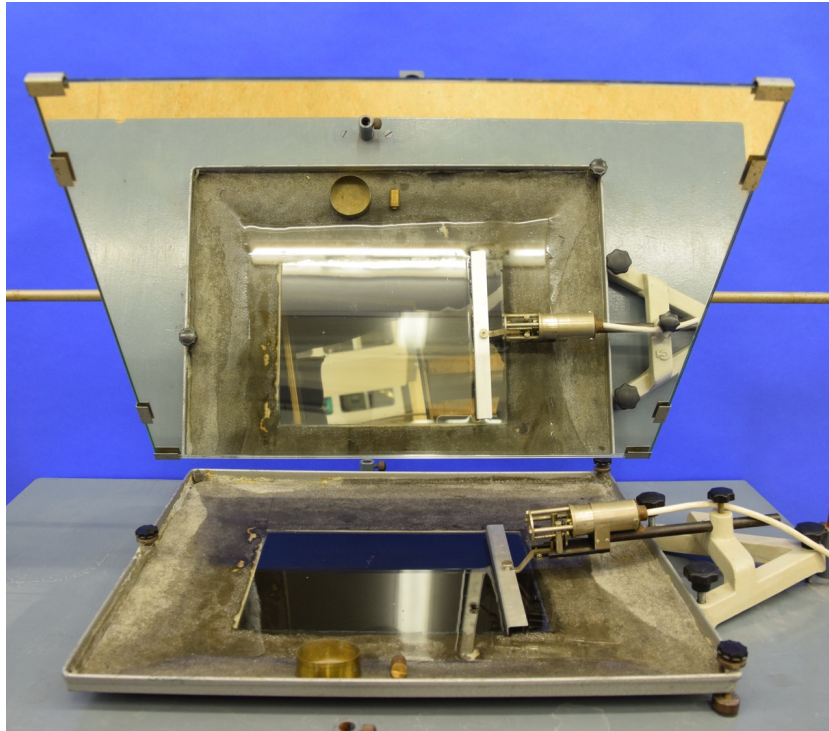

Figure 45: Our ripple tank with a square glass bottom. On the right, mounted on the tripod base, a cylindrical motor is connected to an aluminum bar. At the front, in the ripple tank, are the two cylindrical objects we place in the water. In the back hanging over the ripple tank is a large rectangular mirror. In the mirror you can see the ripple tank, and also look down through the glass bottom.

feel for what happens. We then insert the larger of the two cylinders vertically into the water. It is visible as a dark circular shadow on the screen. At this point the size of the object and the frequency of the waves are chosen, such that the object leaves a clear distortion in the wave pattern all the way to the back edge of the ripple tank. Next we insert the smaller cylinder; its diameter should be smaller than the wavelength. Due to diffraction the waves bend around the cylinder, and are barely distorted behind it. By the time they reach the back of the tank they are plane waves again. We then increase the frequency of the wave generator, which reduces the wavelength. At some point, the distortion pattern clearly reappears behind the smaller cylinder all the way to the back of the tank. Thus at high frequency the smaller object can be resolved.

In order to relate this to high energy physics, we note that a particle can be described as a wave. Smaller wavelengths correspond to higher energies of the particle. We thus need powerful accelerators to look deep inside the protons.

In between, while observing the wave patterns, we play “Surfin USA” by The Beach Boys.

A.9.4 Safety

As water is used, it should be avoided to have open electrical circuitry close by. The mirrors must be carefully wrapped for safe transport.



Figure 46: The complete experiment. On the left is the cat fur next to the red plastic rod. The two plates are electrically isolated from the support structure. The bottom plate is connected to Earth.

A.10 Dancing Paper Men and the Electric Field

This is a very simple experiment which is also very entertaining. We often use it to introduce the concept of the electric field, or to simply demonstrate electrostatic effects.

A.10.1 Materials

The experiment consists of two metal plates, each 28 cm in diameter and 5 mm thick, which are placed parallel to the ground and about 20 cm apart, see Fig. 46. The plates are electrically insulated from each other and from the support structure. Additionally, the bottom plate is grounded, while the top plate remains disconnected. During the show we use a plastic rod and an animal fur to create static charge from the triboelectric effect. This charge is applied to the top plate.

The experiment also requires some small tissue paper figures. While any shape will work, it is important to use lightweight tissue paper (German: Seidenpapier). For our show in Italy we used small blue paper men in reference to the Italian national football team's history of constantly falling down without being fouled.

A.10.2 Presentation

To begin, we lay out the small paper men on the bottom plate of our large horizontal capacitor. The figures should be spread out so that they are not touching each other, otherwise they are more likely to clump up during the experiment, and form a chain instead of bouncing. We then charge the top plate by first rubbing the plastic rod with the fur and then drawing the plastic rod along the top plate. It takes several applications to sufficiently charge the upper plate. The induced charge on the lower plate then charges the paper men and they are attracted to the top plate, see Fig. 11. In the show, at this point, we typically play some rhythmic dance music. At the top plate, the paper men acquire the opposite charge and fall back down. We continue to apply some charge to the top plate, and the paper figures bounce back and forth, giving a dancing effect.

A.10.3 Safety

If the top plate is touched when charged one can get a small electrostatic shock, but there is no real physical danger.

A.11 Linear Accelerator

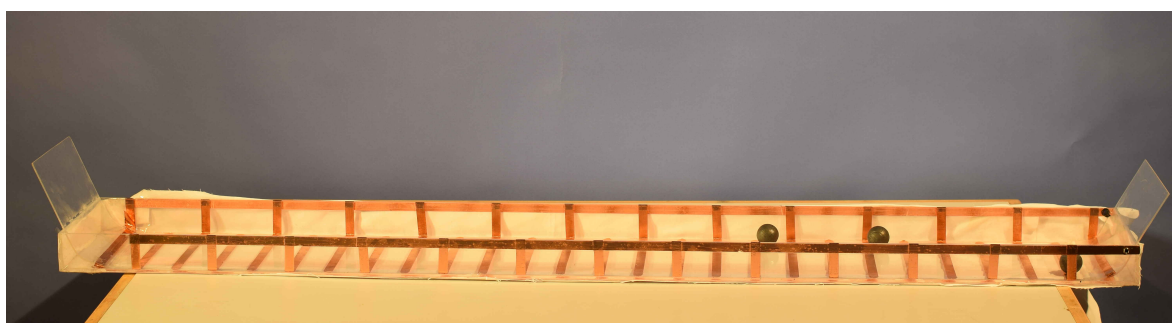

Figure 47: Our linear accelerator experiment. The two ramps can be seen at either end on the left and the right. The box has been underlaid with white paper on the bottom and three sides for the photo.

The linear accelerator experiment helps illustrate some basic principles of accelerating particles. It's worth noting that here the electric charge of the small balls is

changed, while in a true synchrotron the electric field itself would be flipped. The experiment is based on an idea by Jochen Dingfelder (Physikalisches Institut, Bonn) in light of the salad bowl accelerator below, App. A.12, and was built by Sascha Heinz. The experimental setup is shown in Fig. 47.

A.11.1 Materials

The body of the accelerator consists of a transparent plastic box of dimensions $140\text{ cm} \times 20\text{ cm} \times 6\text{ cm}$. At both ends there is a small ramp for the balls to roll up and back down again, and avoid them bouncing out of the box, see Fig. 47. Inside the box on the bottom, we have placed a series of 1 cm wide self adhesive conducting copper strips that run perpendicular to the longer side and are about 5 cm apart from one another. The strips are arranged so that every other strip is connected to a longer strip on the upper left of the long side, and the other strips are connected on the opposing side. On one end of the ramp we have affixed a small socket to each long strip, to easily connect the experiment to a power supply, see Fig. 48. Demonstrating the effect requires at least one light conducting ball, but several balls are more fun. For our experiment we use Styrofoam balls coated in graphite.

A.11.2 Technical Details

For the experiment the two long strips are connected to an AC power source. The potential gap across each strip must be high; in our presentation we use around 25 kV , created with the Wimshurst influence machine shown in Fig. 48. However, the current is less than 0.5 mA , so the experiment is safe to touch. The voltage can not be pushed much higher without creating discharges between the opposite metal strips. Once the potential is applied one or several balls can be rolled along the track.

When a ball touches one of the short metal strips on the bottom side of the box, it acquires the charge of that strip. The ball is then repelled by that strip, while being attracted to the two neighboring strips. The inertia of the ball guarantees that it crosses the strip and is continuously accelerated. In this way each metal strip serves as a gate.

The analogy with a synchrotron has some limitations. In this experiment the ball changes charge at exactly the right moment. With a proton or an electron this is obviously impossible. In a synchrotron it is the electric field that is changed just as the charged particle passes by. We demonstrate this in the mechanical analogy below: App. A.13.

A.11.3 Presentation

In the show we accompany the running of the experiment with music, typically something happy and upbeat. Fig. 49 shows a multiple exposure picture of the linear accelerator in operation.

A.12 Salad Bowl Circular Accelerator

The salad bowl circular accelerator experiment, shown in Fig. 50, employs the same technique as the linear accelerator above, App. A.11, but is circular.



Figure 48: In the show we power the accelerator with this electrostatic generator out of our collection. It is a Wimshurst influence machine, which produces a direct current (DC). We consider it less abstract than a modern power source. The cylindrical objects on the left and right are Leyden jars, which enable more charge collection and thus higher voltages. This experiment is from around 1930. The rotating circular discs with the copper contacts have been restored.

A.12.1 Materials

The body of the Salad Bowl consists of a plastic hemisphere of diameter 90 cm, as can be seen in Fig. 50. Much like in the linear accelerator the inner surface of the plastic hemisphere is lined with 1 cm wide self adhesive conducting copper strips that trace out radii dividing the hemisphere into 16th. Every other copper strip is connected in the center. The other strips are connected to another copper strip that runs along the upper edge of the hemisphere. Thus the bowl alternates between one kind of strip and the other as the ball goes around. We use the same balls as for the linear accelerator in

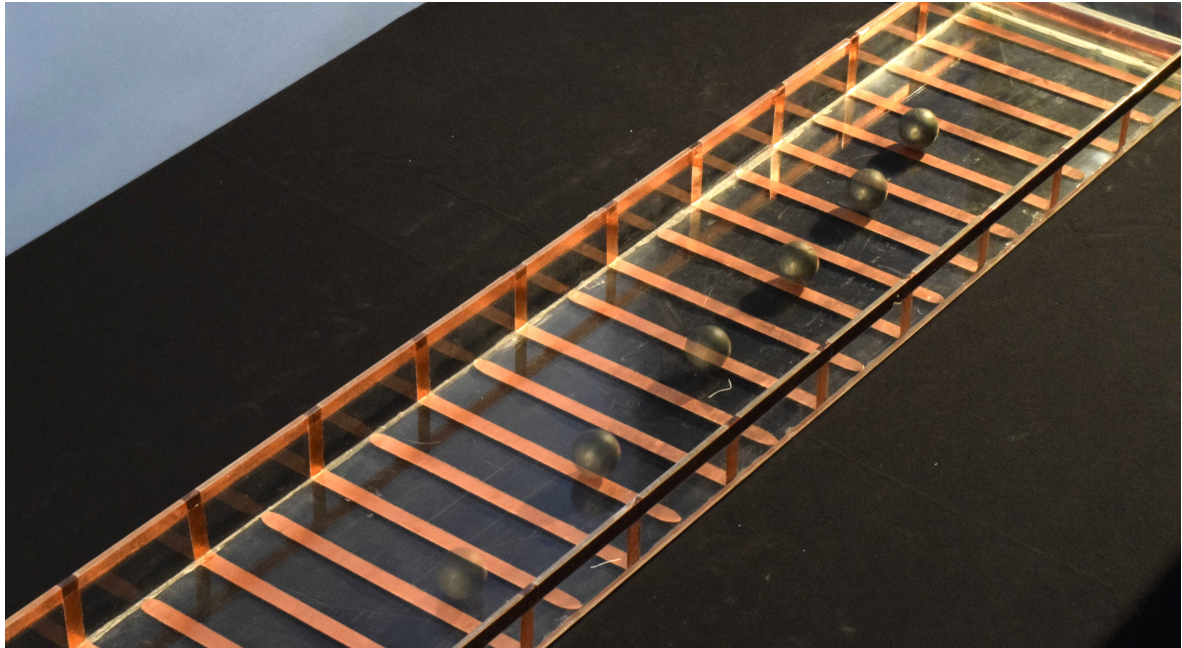

Figure 49: A multiple exposure picture of the linear accelerator in action.

App. A.11.

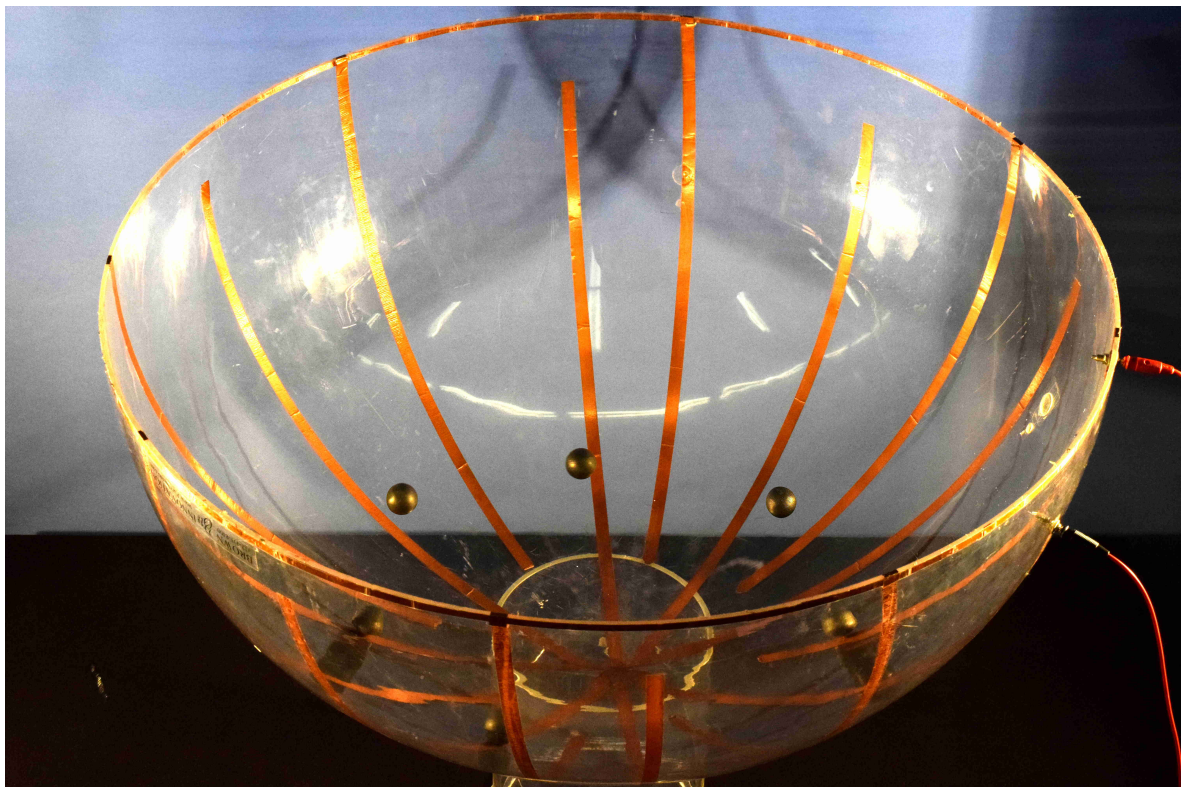

Figure 50: A multiple exposure picture of the Salad Bowl Experiment which highlights the path of the ball. On the right the power hook-ups are visible.

A.12.2 Technical Details

The strips connected along the outside edge and those connected at the center need to be given a large potential difference. In our experience a voltage of 25 kV and a current of 0.5 mA is ideal. It allows the experiment to run well without posing any risk to the user. Higher voltages typically leads to discharges between oppositely charged strips. Once the potential is established, the ball should be started with an angular velocity, similar to starting a roulette wheel. The acceleration mechanism is identical to the linear accelerator, App. A.11.

A.12.3 Presentation

As the ball rotates around the hemisphere, we play music, such as “Get Around” by the Beach Boys.⁹

A.13 Mechanical Synchrotron

This experiment is a mechanical model of a synchrotron accelerator. As presented here it is based on technical drawings from DESY, Hamburg. It was developed in Bonn by Michael Kobel (TU Dresden). A full view is shown in Fig. 12. The Figs. 51 and 52 show some details of the device.

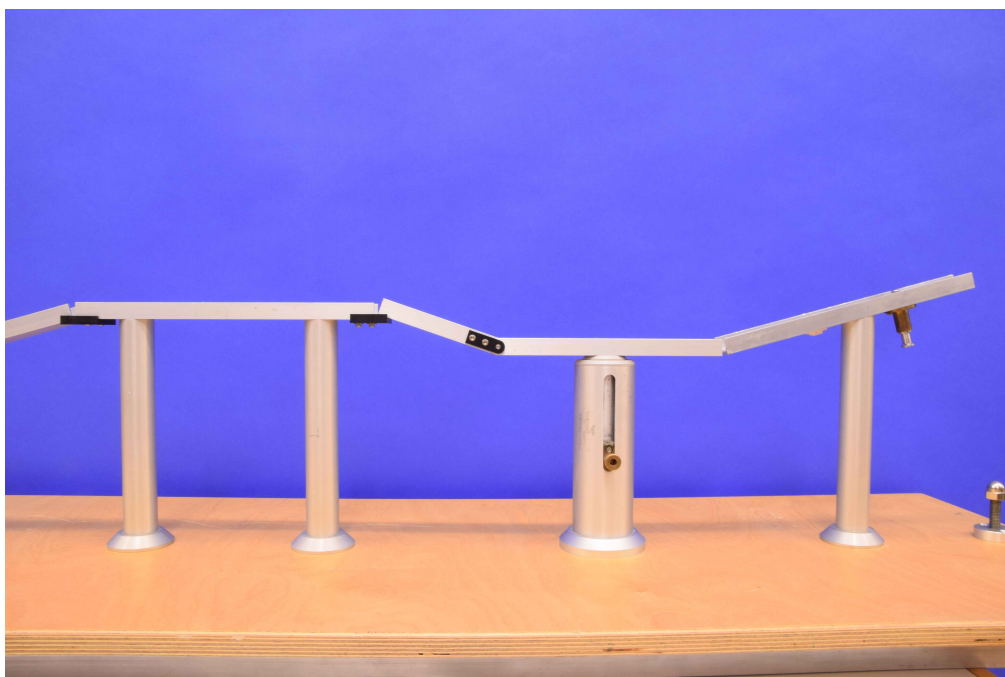

Figure 51: The first segment of the accelerator, with the release point on the right, and the first raising element. An even more detailed view is shown in Fig. 52.

A.13.1 History

Accelerators have played a crucial role in the history of particle physics, and the construction of the LHC was essential for the discovery of the Higgs boson. This is why we

⁹Be sure you have the legal rights to play the music in your shows. We pay the appropriate GEMA fees in Germany for each performance of the show.

have dedicated a complete section of the play to them, Sect. 4.3. Historically, accelerator developments and the directly connected discoveries were honored by several Nobel prizes: in 1939 (E. O. Lawrence), 1951 (J. D. Cockroft and E. T. S. Walten), 1959 (E. Segrè and O. Chamberlain), 1961 (R. Hofstadter), 1984 (S. van der Meer) and 1990 (J. I. Friedman, H. W. Kendall and R. E. Taylor).

If an electrically charged particle is magnetically held on a circular path in a static electric field, its speed does not increase. For an electron and a plate capacitor with two holes for the particle to move through, this may be intuitively clear. Between the plates the particle is accelerated, outside it is decelerated. A static electric field is conservative.

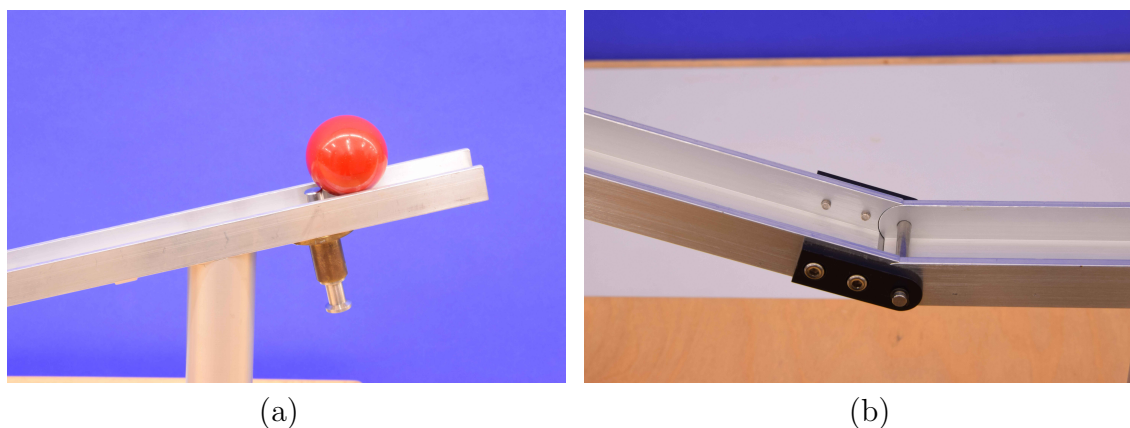

Figure 52: (a) The release mechanism for the ball. (b) A hinge between two moving pieces.

The idea of a synchrotron is to turn the electric field on when the charged particle enters the space between the capacitors, and off, just as it is about to leave. Thus it is accelerated at the right moment, but afterwards not decelerated. The electric field is no longer static, as it must be turned on and off, synchronized with the particle movement. Furthermore, as the particle gains energy, the magnetic field must be correspondingly increased.

For the linear and circular accelerators in App. A.11, and App. A.12, the electric field is held constant. However, the graphite coated balls, change their charge each time they pass over a brass strip. Our mechanical accelerator is thus a better analogy: we raise the potential, just as the ball passes by, *i.e.* synchronized with its motion.

A.13.2 Materials and Technical Details

The accelerator consists of a linear aluminum rail track, resting on aluminum pillars. The rails have a width of 30 mm and a height of 15 mm. The thickness of the rails is 3 mm. Three of the rail sections can be raised and lowered by levers, and the entire apparatus rests on a wooden platform. The overall length of the accelerator is 2.6 m. The wooden platform is 3.00 m x 0.40 m. It consists of two parts, which can be held together with clamps. The accelerated particle consists of a steel ball traveling on the rails. The release mechanism for the ball is shown on the left in Fig. 52, a track hinge is shown on the right. We are happy to provide technical drawings upon request.

A.13.3 Presentation

In the show we have two people operate the accelerator, and one person, who releases the ball, see Fig. 12. In the first run, the second person intentionally lifts his/her rail too early, thus decelerating the steel ball. Over the sound system, we play a sigh of grief: Ooooooh. In the second try it all works, and the ball is noticeably faster. To make it clear, we have a second successful run. It is also possible to measure the final speed of the ball, and display this to the audience.

Outside of a show this experiment is robust enough to use as a hands-on display. In that case students can run a competition on who can produce the highest final speed.

A.14 Flour Explosion

This experiment is added to the show for fun only and for a pun (“flower power”) in the Berkeley part of the play, Sect. 4.3. It has no connection to particle physics. Therefore it might be omitted if problems with safety regulations arise. It shows the flammability of powders. The experimental setup is shown in Fig. 53.

A.14.1 History

This experiment was developed for a previous physics show, on the physics of cooking. The experiment was used to have some extra entertainment while also to educate about the dangers of powder or dust explosions. A pile of flour on a plate does not burn. See also the discussion in [66] on industrial and mining dust explosions.

We also considered a smaller version of this experiment within a glass box, but the effect was not as impressive and the ignition probability much lower. For the demonstration as discussed here, additional safety measures have to be taken, as described in App. A.14.4.

A.14.2 Materials and Setup

This experiment requires a rubber hose, about 1.5 m long, with an inner diameter of about 5 mm, a blow torch, some duct tape, a sturdy plastic bottle and sufficient flour. The effect works better the smaller the grains of the flour. We fix the bottle with a structure, such as used for flask holders in chemistry labs. This in turn should be fixed to a table or cart to avoid uncontrolled fires.

In principle other powders can be used, such as pepper, paprika, toner powder, or lycopodium powder. Though these are usually quite expensive in larger quantities. Metallic powders can lead to stronger explosions.

We cut off the bottom of the plastic bottle. Compared to a standard funnel the bottle has the advantage of an elongated body which directs the flour upwards. The hose is inserted in the narrow end of the bottle and sealed well with the duct tape. A picture of this construction is shown in Fig. 53. The bottle is then placed in the holding structure and filled with flour. About 100 g of flour is sufficient. Only the conical part of the bottle has to be filled with flour for the best effect.

A.14.3 Presentation

After motivating the experiment, one person briefly explains the setup while the other fills the flour in the bottle. Afterwards they both put on safety glasses and gloves. We



Figure 53: Close-up of our flour explosion experiment. On the left the conventional baking flour. On the right the gas blow-torch. the support structure holds the inverted and cut plastic bottle. A long tube is connected to blow into the bottom of the bottle from a safe distance.

also point out that this experiment should **not** be performed at home. One protagonist holds the ignited blow torch with an elongated arm above the bottle opening. Some music is started, possibly hard-rock with some fire context (Rammstein, Bloodhound Gang). As the other protagonist blows in the far end of the hose, both protagonists keep a safe distance from the bottle, see Fig. 13. After the first run there is usually enough

flour left in the bottle that when shaken a second one can be done without refill.

A.14.4 Safety

This experiment involves large flames. The distance to the audience should be at least 3 m. The bottle needs to be securely fastened to an immobile structure to avoid it falling in any undesired direction. Above the bottle there should be more than 2.5 m space for the flame. The material usually burns up in the air, nevertheless a non flammable floor covering should be used. This also allows for easy removal of the leftover material. Both presenters should wear safety glasses and gloves.

A.15 Vacuum Cannon

The vacuum cannon, see Fig. 54, also known as vacuum bazooka, or ping-pong cannon is a well-known demonstration experiment. It is listed as PIRA 2B30.70 in the Physics Instructional Resource Association¹⁰ [67].

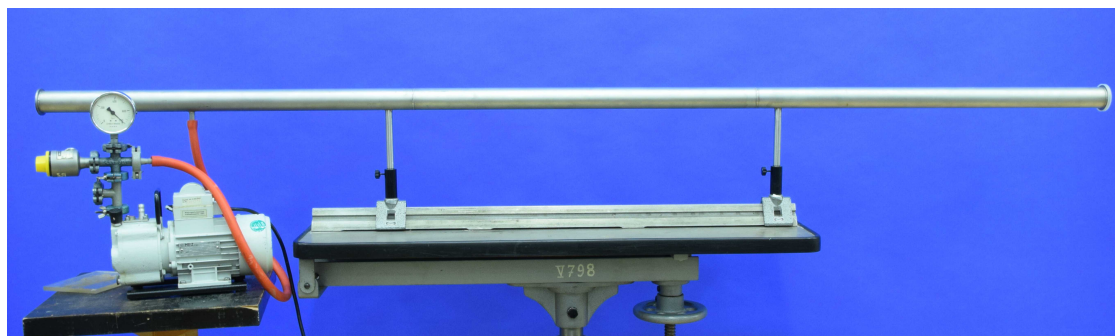

Figure 54: An overall view of our vacuum cannon, without the detector.

A.15.1 History

The first vacuum cannon was built by Otto von Guericke. It is first mentioned in 1672 in chapter 29 of the third book of [69] and called a “Windbüchse”. It was certainly built much earlier. Fig. 16 in [69] depicts a beautiful engraving of the historical experiment. Von Guericke also invented the first piston vacuum pump in 1654 [70], and performed for example his famous experiment with the Magdeburg hemispheres pulled by horses, see Fig. 11 in the 23rd chapter of the third book of [69] for a wonderful full page engraving with 16 horses. Other Windbüchsen had been built earlier, possibly already in the 15th century in Nürnberg, however these were based on overpressure [71].

As a fun modern demonstration experiment the vacuum cannon is mentioned in 2001 in Ref. [72]. Modifications have been discussed in the literature [73, 74], including also a theoretical analysis [75] resulting in an upper bound on the exit velocity as a function of the length L of the tube

$$v_{max}(L) = \sqrt{\frac{P_0}{\rho}} \left[\frac{L}{L + \frac{m}{\rho A}} \sqrt{1 + 2 \frac{m}{\rho A L}} \right] \xrightarrow{L \gg \frac{m}{\rho A}} \sqrt{\frac{P_0}{\rho}} \approx 290 \frac{m}{s}. \quad (4)$$

¹⁰We were not able to find it at the official site [67], but found a corresponding description under this number at [68].

Here P_0 is the atmospheric pressure, m is the mass of the projectile, ρ is the density of air, A is the cross sectional area of the tube, L its length, so that ρAL is the mass of the air in the tube after the projectile has been emitted. The asymptotic speed on the right is achieved for large tube lengths. The resulting numerical value assumes normal air pressure and density conditions ($P = 101 \text{ kPa}$ and $\rho = 1.25 \text{ kg/m}^3$). A numerical analysis of the projectile acceleration, including fluid dynamics was performed in a Master's thesis in Ref. [76]. See also the related work in [77].

The design widely discussed in the literature employed a 2 to 2.5 m PVC or acrylic tube and a ping-pong ball as a projectile. The ends were sealed with tape. In order to launch the cannon the tape at one end was pierced with scissors or with a sharp knife.

In 2006, we designed and built our own cannon.¹¹ We have modified the setup, as we describe below, and have also changed the outlook or context of the experiment, to use it as an analogy for a particle physics, fixed-target experiment. Thus we also modify the exit setup, including a “target” and a “beam dump”, see Fig. 56.



Figure 55: One of us (HKD) with the injection side of the vacuum cannon. The vacuum pump as well as the hook-up via the red rubber hose is shown. The wooden projectile is just at the entrance to the pipe, together with the greased plastic plate seal.

A.15.2 Materials and Technical Details

An overview is shown in Figs. 2, and 54. More details can be seen in Figs. 3, and 55. The main cannon consists of a 2.2 m long V2a steel (non rusting) pipe. It has an inner diameter of 40 mm and a wall thickness of 2.25 mm. At each end of the pipe there is a flange welded to the pipe, providing a larger area to seal the tube. In the middle, a connector has been welded to the pipe, where the vacuum pump is attached. Two further metal rods are welded to the long pipe, for mounting on an optical bench. See also Fig. 54. At the exit end a simple plastic cap seals the pipe. At the entrance, we

¹¹We heard of the vacuum cannon via Tilman Plehn, who told us of one built at Boston University.

use a 20 cm x 20 cm plexiglas plate as a seal. At both cases we use lubrication grease to improve the seal. After evacuation, in order to fire the cannon, we pull down the plexiglas plate. Not much force is needed. We find this much better than sealing the pipe with tape and puncturing it with scissors or a sharp knife. It also allows us to reuse the cannon fairly quickly.¹²

We use either a 130 W, 2.5 m³/h or a 370 W, 12 m³/h vacuum pump; both have a pressure gauge, which we display via camera onto the large screen in the shows. With the stronger pump the evacuation time is about 10 s, with the weaker pump about 1 min. We usually prefer the weaker pump, as, when accompanied by appropriate music, it adds some drama in a live show, as the pressure gauge slowly drops. Furthermore the stronger pump requires three-phase alternating current, which is not available at most places we perform.

The cannon is pointed at a target, which is placed very close to the cannon exit, see Fig. 3. We use “quark”, a dairy product, which is readily available in supermarkets in Germany. It comes in 250 gr or 500 gr plastic containers; we use the 500 gr packages. It is similar to cottage cheese in the USA, or *frommage blanc* in France. We choose it, since the particles inside of a proton are also called quarks.¹³ Furthermore when struck by the projectile, the quark gives a good splatter. We often enhance this by adding food coloring to the quark.

The quark target is placed inside a transparent plexiglas box of dimensions 30 cm x 30 cm x 42 cm, see Fig. 56. The material is 6 mm thick. On the upstream side, we leave an opening of dimensions 10 cm x 11 cm, where the projectile enters. We then place the end of the cannon inside the plexiglas box, directly against the quark container. The back side of the box, facing away from the cannon is completely open. This plexiglas box acts as our detector, recording the single event we create. It is fixed to the wooden platform it rests on with a screw clamp.

Behind the plexiglas box, on a separate stand, we have a wooden box of dimensions 40 cm x 40 cm x 60 cm, made of coated 19 mm chipboard. This box is filled with toilet paper rolls, which absorb the shock of the projectile. The side of the wooden box facing the cannon is open. We cover it with a tough garbage bag, taped to the box. This also prevents the quark from entering the box and makes for easier cleaning. This box serves as our “beam dump”, see Fig. 56.

As a projectile we use a wooden ball with 40 mm diameter, or a more bullet shaped one with the same diameter and 68 mm length. It can be seen in Fig. 3 and Fig. 55. We have not measured exit velocities.

After all seals have been applied and checked the tube is evacuated. After the desired pressure is reached (about 10 mbar), as read on the pressure gauge, the pump is switched off to protect it from the shock of the inflowing gas. Depending on the type of the pump an intermediate valve might be needed for protection.

Finally, the plexiglas plate at the entrance end is removed in a fast downward movement. The inflowing air propels the projectile to the front. It pushes out the front cover

¹²In the performance at ICTP Trieste, this was useful as the cannon misfired on the first attempt, a rare occurrence, and we could repair it by the DESY part, where it reappears.

¹³Howard Haber recalls to have heard the story, that James Joyce, heard the phrase “*Drei Quark für eine Mark*” (transl.: “three (packets) of quark, for one mark”) from a market vendor. This then supposedly became “Three quarks for Muster Mark!” in *Finnegan’s Wake*. Joyce lived in Zürich for an extended period and is in fact buried there. However, he must have heard this while travelling in Germany, as Switzerland has had the *Franken* as its currency for about 200 years. This story is mentioned in Ref. [78], as apocryphal. They also mention that supposedly there was a German commercial slogan to the above effect at the time.

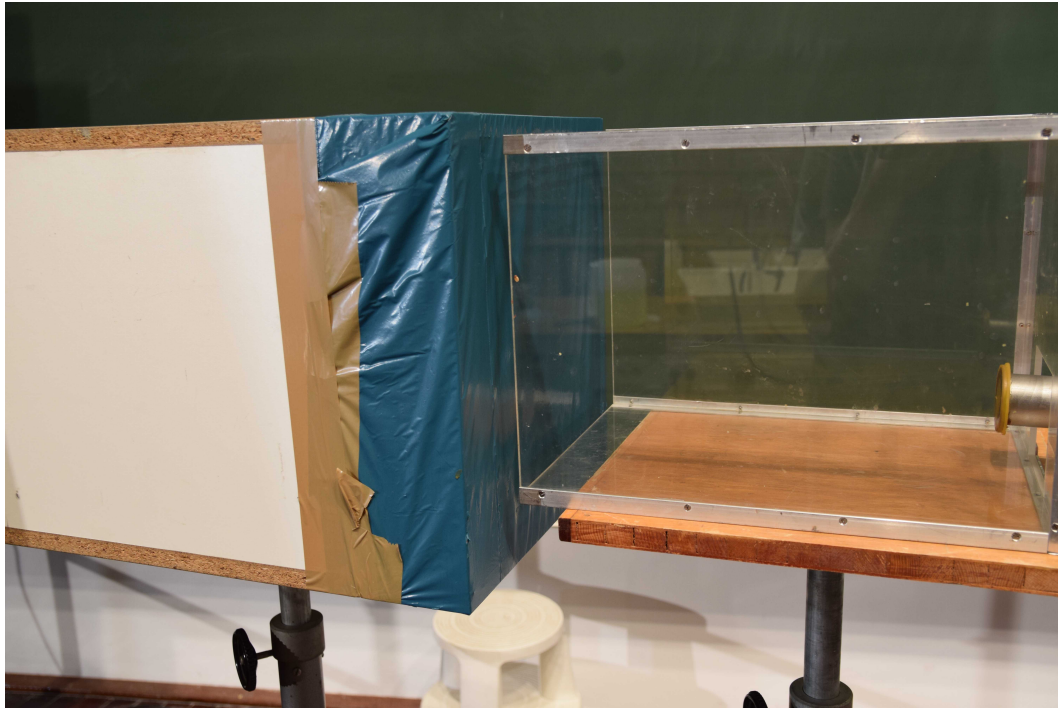

Figure 56: A detail of our vacuum cannon experiment. The end of the vacuum cannon is on the right, entering the plexiglas box. We place the Quark packet just in front of the pipe. On the left is the wooden box we use as a beam dump. In blue is the garbage bag, taped to the box.

and then hits the desired target. The quark container is ripped apart and the quark splashes all over the inside of the plastic “detector”, see Fig. 3.

Since quark is not readily available outside Germany (in Austria it is called “*Topfen*”), when we go on the road, we must buy the quark in Bonn and cool it during transport.¹⁴

A.15.3 Presentation

The presentation of this experiment is usually enacted quite dramatically. Depending on the available space on- and offstage the cannon is either onstage throughout the relevant sections of the play or wheeled in on short notice. Similarly for the detector and the beam dump. If they are onstage beforehand for an extended period of time, they are covered with a black cloth. The presenter introduces it as a “real particle accelerator”, which is revealed, by removing the cloth. Then the presenter explains the apparatus, in particular the vacuum pump, and how it is connected. If the apparatus is shown on the screen, the parts can be highlighted with a laser pointer.

Next a proton target is required. The quark is delivered by a crew member, or in this show by the caretaker. He holds it into the camera so the “Quark” label can be easily read via the projection. It is placed inside the detector and the cannon is carefully lined up, with the exit just in front of the quark, inside the detector. We have several variations on how to present the accelerator, and also the quark. For example the latter can be brought in from offstage, held up high, almost like a religious relic. The presenters of the experiments wear lab coats and put on safety glasses before starting the vacuum pump. Then the projectile is inserted, the openings are sealed and the pump

¹⁴Apparently quark is now sold at Whole Foods in the USA [79].

is started, giving the typical loud noise of a vacuum pump. Depending on the show and the speed of the pump, this time can be covered by more music or explanations of the host, *i.e.* referring to the discovery of point-like particles in the atomic nuclei by fixed-target scattering experiment.

When the desired level of pressure is reached, the pump is switched off and the rear opening of the tube is uncovered. We usually stage that with some more action like adding personal protection, *i.e.* goggles, and someone on stage yelling “Fire!”.

The projectile hits the target, spilling quark in all directions, *cf.* Fig 3. After the dust has settled one of the hosts acts as an analyzer, or does a read-out by tasting the spilled quark. Due to the German word “quark” this is an excellent opportunity for some cheesy¹⁵ puns, *e.g.* “Hmm, tastes strange!”. See also the extensive dialogue in the play in Sect. 4.4.

If one chooses the target appropriately the result can be spectacular. In the show we use quark, but we have also used watermelons, for example.

A.15.4 Particle Physics Analogy

In our show the vacuum cannon is used as a demonstration of a fixed-target scattering experiment. The cannon itself is the accelerator, the quark is the target, while the projectile represents the beam particle. The box in the back is the beam dump, see Fig. 56.

A.15.5 Safety

The projectile leaves the cannon with significant velocity. Care must be taken to ensure the cannon is only fired into the beam dump and never into open space. The spillage of the target material can often not be entirely contained within the target housing. Some backfire through the opening for the projectile can occasionally reach the presenters and more quark is spilled when disassembling the experiment. Hence, care should be taken to protect carpets or any other flooring that might be hard to clean or any nearby objects that cannot stand some drops of cottage cheese.

A.16 Testicle Model

This is a simple model of three hard balls wrapped inside a balloon, as an analogy for the quarks inside a nucleon.

A.16.1 Materials

This is a simple self-made experiment: three wooden balls with a diameter of approximately 5 cm are squeezed inside an uninflated balloon and thus held together. It is shown in Fig. 57. The surface of the balls should be smooth, so that the skin of the balloon is not ruptured.

A.16.2 Technical Details

The model represents the effect of the strong force in hadrons. The quarks, represented by the wooden balls, are almost free in their movements as long as they are close

¹⁵No pun intended.

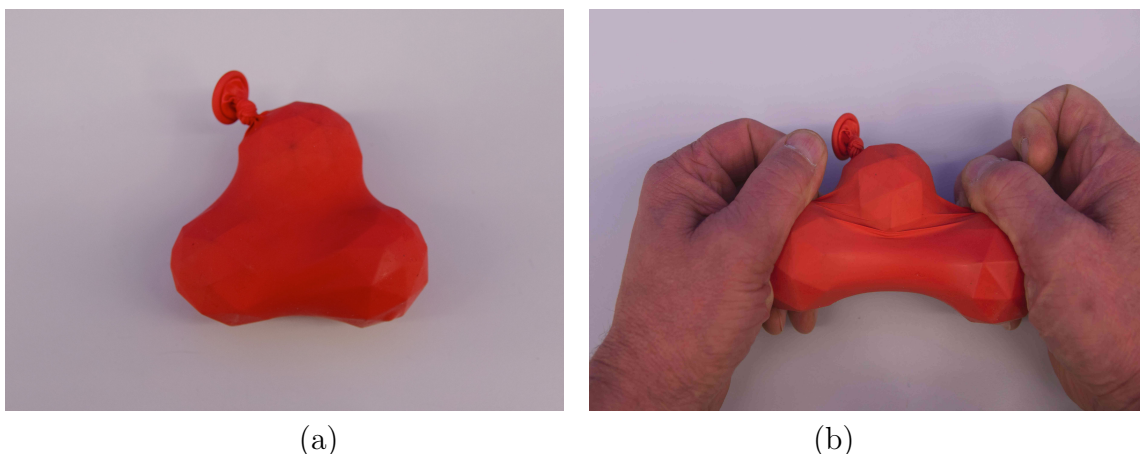

Figure 57: (a) The testicle model (balloon bag model) for the proton. (b) Stretching the model.

together. But if you try to remove one quark, the confining force rises linearly with the separation, and you find it is not possible, see Fig. 57.

A.16.3 Presentation

Since the model is relatively small, the stretching of the balls in the balloon is filmed with a camera and shown on screen. The experimenter pulls the balls away from each other and lets them snap back. By this, it is demonstrated that the nucleon consists of three parts, which can be detected, but not separated. In the show, as a joke, we sometimes call this the “testicle model”. We then play an “ouch” noise with the fast recoil of the balls to imply pain.

A.16.4 Safety

If you are careful with the snapping back of the balls inside the balloon, this experiment is harmless.

A.17 Balloon Tossing

This experiment is an analogy to show that a particle with substructure, such as the proton behaves differently from a homogenous particle.

A.17.1 Materials and Technical Details

For this experiment, two medium sized balloons of different color are needed. Once inflated they should have a diameter of about 25 cm. In one balloon we inserted a bouncy ball (super ball, with a diameter of about 5 cm) before inflating. Bouncy balls are typically smooth, so that the balloon is not punctured.

A.17.2 Presentation

This experiment is typically performed together with a volunteer from the audience. We do not disclose to the audience in advance that one balloon has a bouncy ball inside. The audience member together with a member of the show stand approximately 5 m

apart on either side of the stage. First the empty balloon is tossed back and forth. It flies like a normal balloon slowing down and eventually dropping vertically, barely covering the 5 m. This represents the early version of the proton which behaves as a homogeneous mass. Next the show member tosses the other balloon. It flies erratically and is very difficult to catch. As this behaviour is unexpected, the participant from the audience is usually suitably surprised. The balloon is then tossed back, again flying erratically. The balloon can then be punctured, revealing the bouncy ball inside. This second proton, closer to today's view, has substructure which is revealed through its macroscopic (compared to the size of the balloon) behaviour. This substructure, which takes the form of quarks inside the proton, was revealed through the use of scattering experiments.

A.18 Air Table and Strong Force

With this experiment we wish to demonstrate how a strong, attractive short-range force can overcome a weaker long-range repulsive force.

A.18.1 Materials and Technical Details

The experiment requires an air table, as well as two or three pucks. An overall view is given in Fig. 58. Our air table is 80 cm x 60 cm and is mounted on a cabinet on wheels. The cabinet is 85 cm x 70 cm and including the wheels, 80 cm high. The pump for the air flow is stored inside the cabinet. This allows for easy transport on- and offstage. A camera which looks down onto the air table is connected via a metal arm to the side of the cabinet. Along the edges of the air table a taut wire at about half the height of the pucks guarantees that the pucks bounce back almost elastically. The pucks should be of identical size and shape, but with differing colors, to easily distinguish them. Each puck must have a magnet within it, with the same orientation, *e.g.* the North pole upwards. We also require a Velcro ring for the pucks, which fits tightly, but does not impede their low-friction sliding across the table.

A.18.2 Presentation

The experiment is performed in two stages: First we demonstrate the repulsion of protons by the electric force for same charged particles, here however represented by magnets, see Fig. 59(a). Then we demonstrate the short range binding qualities of the strong force, see Fig. 59(b).

We start with the two pucks on the air table and try to place them near each other. These pucks are meant to symbolize protons in the nucleus. The magnet within them is a representation of the repulsion created by their equal electric charge. When we let go of the two protons they repel each other. If we try to shoot them together, *i.e.* use kinetic energy, they will just deflect and fly apart because of their identical electric charge. If there was no other force this is what would occur in the nucleus of an atom. Then we add the Velcro to the pucks and collide them, with little energy. Again they repel each other. However if we collide them with higher energy, they get close enough for the Velcro to take over. Then the two pucks stick together and start to move in unison. The Velcro symbolizes the strong force interaction, which has no effect over large distances but is incredibly strong when the two protons are close, as in the nucleus.



Figure 58: Overall view of the air table with two pucks on it. On top is the camera, which we use to project the puck interactions onto the big screen. The cabinet underneath contains the air pump. You can also clearly see the taut wires, which keep the pucks on the table.

A.19 Photon Clicker

This experiment demonstrates the quantum nature of light. After a filter attenuates the light emitted by a laser, individual photons are detected by a photomultiplier tube which is connected to a loud speaker. In this way the audience can hear a clicking sound for each individual photon.

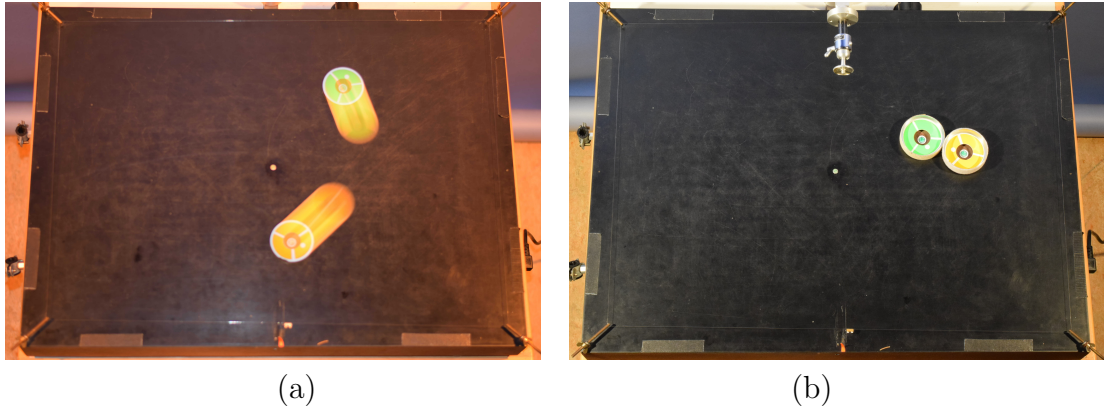

Figure 59: Top down look onto our air table, which we use as an analogy for the strong force. In (a) no Velcro or strong force is present, the magnetic force causes the two protons to repulse each other. This is shown here by an extended exposure in the photo. In (b) the Velcro overpowers the repulsive force of the magnets at short distances and the two protons stick together.

A.19.1 History

The photoelectric effect was discovered by Heinrich Hertz in Karlsruhe, in 1887 [80]. He noticed that the emission of sparks in his spark-dipole, used for (producing and) detecting electromagnetic waves, was enhanced by external light. Together with detailed investigations by his assistant Wilhelm Hallwachs he showed that the UV component of light leads to the strongest effect [81]. Einstein was able to interpret this in terms of the quantization of electromagnetic radiation and postulated the photon [82].

The apparatus we use in the show was originally designed in Bonn by Remmer Meyer-Fennekohl and Antoine Weis. It was part of the exhibition ‘*Quantenphysik heute - Quantenphysik morgen*’ on quantum physics in the Deutsche Museum, Bonn, in the autumn of 2000 [83]. In Ref. [84] three demonstration experiments on the wave and particle nature of light are described. The first is exactly the setup we use here. (The second experiment describes the diffraction of light from a double slit. In the third experiment the latter is refined to single photons, slowly building up the diffraction pattern.) In Ref. [85] these ideas are extended to interference. There you can hear the interference pattern. We use a rebuilt, smaller version, which is easier to transport.

A.19.2 Materials

The apparatus we use in the show is shown in Fig. 60. On the left, we see a red laser diode with adjustable power (< 1 mW), which is used as the light source. The intensity is reduced to 0.001% of the initial intensity by a neutral density filter with $ND = 5.0$. The laser beam is adjusted to a pin hole mounted in an aluminum tube, which additionally shields the detector. The detector is a Hamamatsu Photosensor Module H5784-20, which is comprised of a photomultiplier tube, a high-voltage power supply and a low noise amplifier. See Fig. 61 for details of the attenuation in front of the photomultiplier.

The amplifier output is connected to usual active PC speakers. Everything is mounted on a plate, so that the alignment is stable and it is easy to carry on stage.

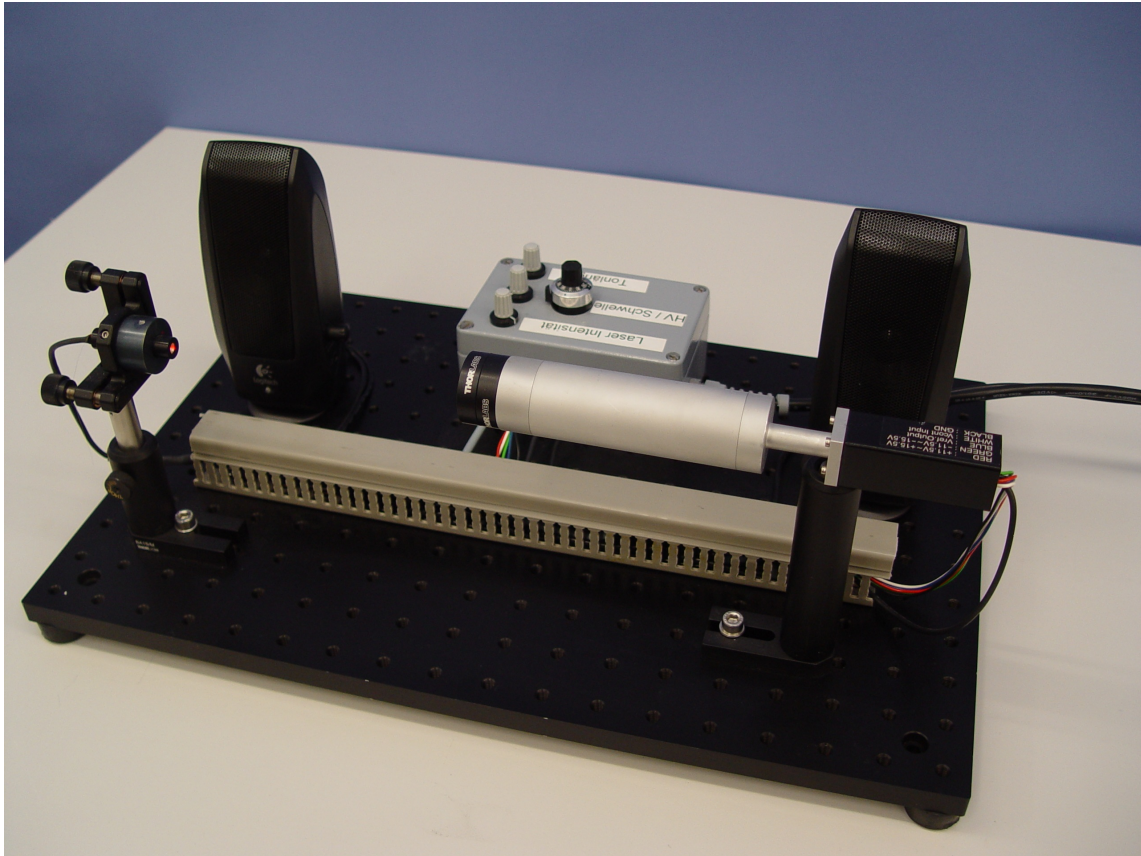

Figure 60: Photon clicker experiment. The red dot on the left is the laser. The black box on the right is the photo multiplier. The setup is described in more detail in the main text.

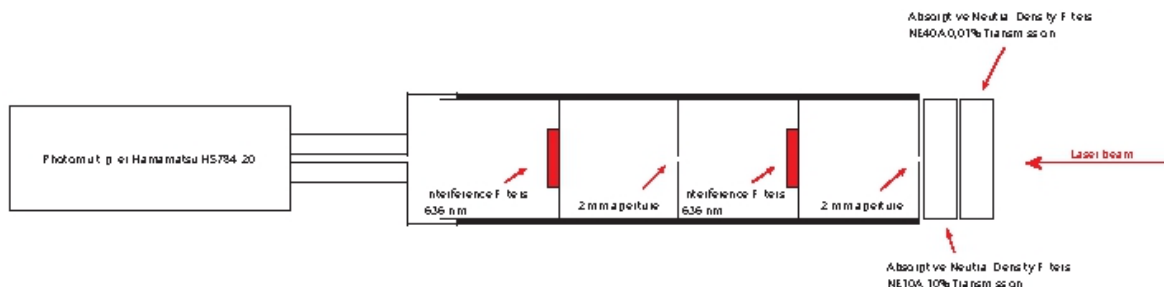

Figure 61: A schematic drawing of the attenuation and detection of the photon clicker experiment. The laser beam enters from the right. The photomultiplier is on the far left. The laser beam first encounters two absorptive neutral density filters, then two 2 mm apertures alternating with two 636 nm interference filters.

A.19.3 Presentation

Guiding the audience through the setup is especially important for this experiment, because most people are not used to the devices and their function and they are quite small. Depending on the size of the auditorium, the speaker sound should be amplified for the audience, possibly with a hand-held microphone. The presenter should always block the beam, or turn off the speakers, while talking to avoid disturbance by the detector sound.

The presenter starts with the laser at high intensity. By holding a sheet of paper

between the laser and the detector she shows the red dot on the paper, indicating that the laser is on. She then introduces the photo multiplier as a device for light detection and switches on the speakers. The light intensity should be high enough to produce continuous noise. The presenter demonstrates that the sound is caused by the light by again blocking the laser beam with a sheet of paper several times. This eliminates the noise. Then she she reduces the intensity of the laser and invites the audience to listen carefully. She adjusts the light intensity until single clicks can be clearly distinguished and explains that you can now hear individual photons.

A.19.4 Safety

Standard precautions for the usage of lasers must be taken. The laser is operated at low power and is fixed on the apparatus, greatly reducing any risk. The presenter should not hold anything reflecting, *e.g.* a wrist watch, into the beam.

A.20 Tossing Medicine Balls on Inline Skates

In this experiment we want to visualize how two particles can exert a force on each other by exchanging a mediating particle, as in quantum field theory. Two people wearing inline skates throw a medicine ball back and forth and through momentum conservation repel each other, see Figs. 15 and 63.

A.20.1 History

In the literature, a similar analogy is widely used to describe a repellent force through an exchange particle. In Fig. 62 we show an example where two people on separate rowing boats exchange a large heavy object. Yellow arrows indicate their resulting motion.¹⁶ However, this is highly impractical onstage. We have thus altered this to two people on inline skates, exchanging a medicine ball.

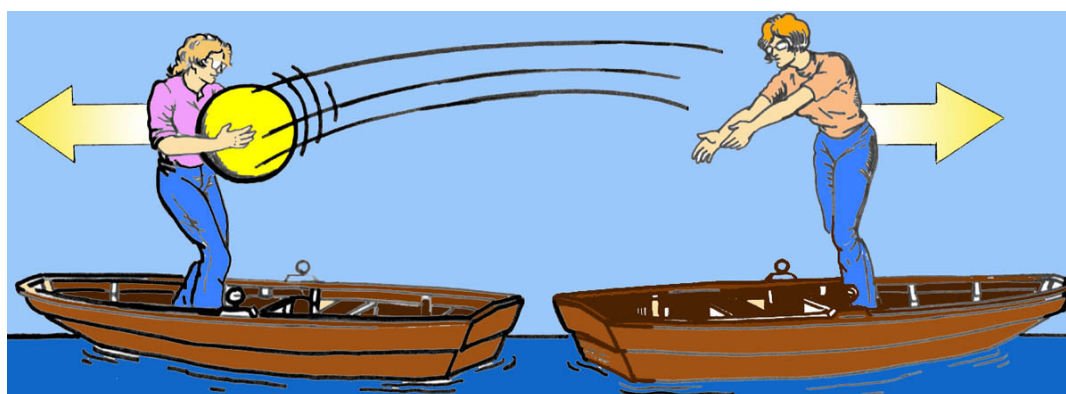

Figure 62: Two people on rowing boats in the water exchanging a heavy object, and thus repelling each other. We thank Daniel Class and Don Lincoln for allowing us to use this picture.

¹⁶It seems more likely that they would actually fall in the water!

A.20.2 Materials and Technical Details

This demonstration requires a 5 kg medicine ball and two pairs of inline skates. Furthermore, for this experiment a lot of space is needed, and preferably a hard floor. Inline skates do not work as well on carpeted floors. Although we managed at ICTP Trieste.



Figure 63: AF (right) and HD (left) exchanging a medicine ball during the show in Padua. On the left in the back is MBr as Haimo Zobernig and on the right is KH as Sau Lan Wu. In front of KH you can see the air table of experiment of App. A.18. Partially covered by AF is JSchm as the Caretaker.

A.20.3 Presentation

After announcing the two participants, in our case a professor and a student, they skate onstage, one of them holding the medicine ball in his hands. Both place themselves in the center of the stage about 1 m apart. A moderator points out the inline skates and the medicine ball and opens the stage for the experiment. The two people throw the medicine ball back and forth several times until the distance between them increased to about 5 m, or as far as they can throw the ball and the stage allows. Afterwards, both skate closer to each other and the procedure is repeated once. Both skaters stay onstage for the explanation of the experiment by the moderators and then exit. During the explanation, as a joke, it can be pointed out that students and professors repel each other.

A.20.4 Extension: Collider

In a previous show, we have extended this to include pair production and annihilation. For this we had two assistants walk in holding a screen, behind which they could hide, but behind which also the skaters could vanish. The assistants had two medicine balls with them. The two people on inline skates entered the stage from opposite sides and then together vanished behind the screen. Then they immediately took the medicine

balls and threw them out. That was pair-annihilation. Here one proponent was a professor and the other an anti-professor, *i.e.* a student. We often also displayed a Feynman graph of the process via the projector.

Next two people from the outside threw the medicine balls back to behind the screen, the two proponents on inline skates caught them, handed them to the two holding the screen, and skated back out again: pair production. Here we also showed the Feynman graph, by simply rotating the previous one by 180° .

A.20.5 Safety

This experiment needs a lot of space onstage, which needs to be free from any cables or other things which could trip the skaters. Also skaters should practice throwing and catching a heavy ball while skating. If they feel unsure they should wear helmets.

A.21 Relativistic Bicycle

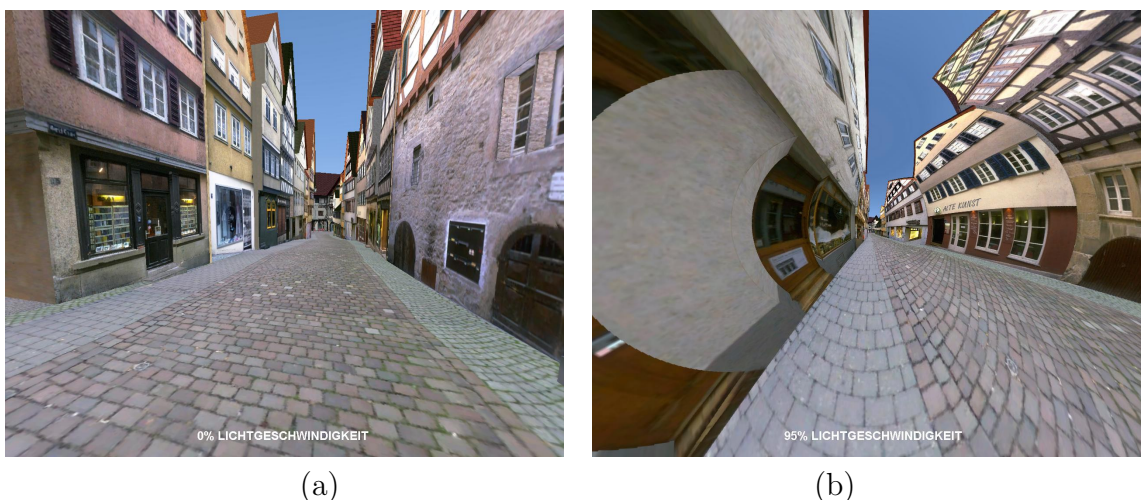

Figure 64: Screen shots of the program from Tübingen described in the text [86, 87]. The speed of the bicycle in terms of the speed of light can be seen at the bottom of each screen. (‘Lichtgeschwindigkeit’ = ‘speed of light’, in German) (a) shows the image of a street in Tübingen at rest. (b) corresponds to a distortion at 95% of the speed of light.

In this experiment a computer simulation, visualizes the world as seen from a bicycle travelling close to the speed of light [86, 87]. The simulation is hooked up to a fixed exercise bicycle, set onstage. “The world” here is a digitized 3D model of the city of Tübingen, see Fig. 64 (a). The speed of light has been reduced to about 30 km/h, so that a moderately fit person can achieve dramatic effects. The distorted, relativistic view onscreen, see Fig. 64 (b), then corresponds to the speed of the cyclist onstage. The essential feature is that objects are to first order not length contracted [88] but rotated and thus distorted through the relativistic effects.

A.21.1 History

The relativistic effects shown here were inspired by drawings in George Gamow’s book *Mr. Tompkins in Wonderland* [89], in which he describes a cyclist riding through a town, where the speed of light is 30 km/h. The houses on the left and right are length



Figure 65: LU on the relativistic bicycle during rehearsals at Padua University. On the left is JSchm as the Caretaker wearing his German helmet for the DESY part, described in Sect. 4.4. On the right are JH and CJ at the table where the lighting, sound, and projection are controlled.

contracted. However, A. Lampa and J. Terrel showed that this does not occur [90, 88]. This inspired U. Kraus and M. Borchers of Tübingen University to develop a program which also includes the rotational effects due to the finite speed [86, 87]. For early work on these rotational effects (aberration) see for example [88, 90, 91]. For a more pedagogical treatment see the Physics Today article by Victor Weisskopf [92]. The essential feature is that the light recorded by the eye or by a photograph arrives simultaneously, but due to differing distances travelled it was not emitted simultaneously. A nice very short film showing the lack of contraction for a sphere is given at the website [93].

A.21.2 Materials and Technical Details

In the show we use a fixed exercise bike which allows for rotation of the handle bars around a vertical axis, as in a normal bicycle, see Figs. 16 and 65. Electronics on the bicycle register the steering and the pedal rate and transmit this to a computer (PC) via a USB connection. The software we use here has been developed at Tübingen University [86, 87]. It employs a digitized 3D model of the city of Tübingen developed by H. Bühlhoff (MPI Biological Cybernetics, Tübingen), see Fig. 64. The speed of light is set to approximately 30 km/h. The PC is connected to a projector to present the simulation onstage.

A.21.3 Presentation

In the show the bicycle is employed as a way to imagine what it is like to zoom through an accelerator tunnel close to the speed of light. The presenter introduces the *relativistic bicycle*, shows the cables which connect it to the computer and thus to the screen, where the bicycle speed is indicated as a percentage of the speed of light. The person riding the bicycle, see Fig. 65, accelerates slowly (almost) up to the speed of light, brakes and repeats this a few times. On the screen, the audience can see the distortion of the buildings with increasing speed, see Fig. 64. We usually play “*Bicycle Race*, by Queen” during the ride.

A.21.4 Additional Information

The relativistic bicycle has been onstage only in this particle physics show. It is very sturdy and also suited as a hands-on exhibit. In 2005 it was successfully used at the Deutsche Museum Bonn. During the intermission in our regular (non-particle physics) shows, we always have many experiments, which the audience can try themselves under supervision, including sometimes the relativistic bicycle.

A.21.5 Safety

The bicycle is quite heavy and stable, so a crash helmet is optional. 😊

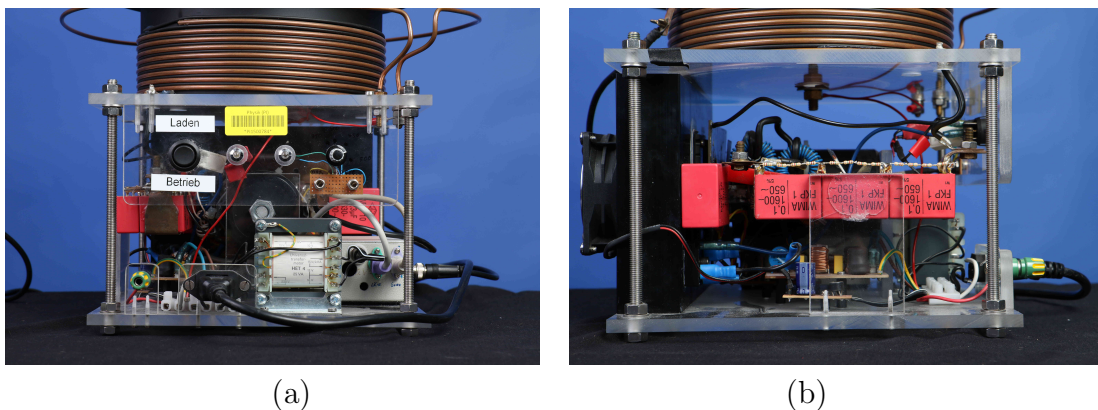

Figure 66: Close-up of the electronics of our Tesla coil, (a) front, and (b) side.

A.22 Tesla Coil

A Tesla coil is an electrical resonant transformer circuit which is used to produce high voltage at high frequencies and low currents. The high voltage is discharged via extended lightning bolts. The Tesla coil we use creates bolts up to a length of about 1 m.

A.22.1 History

The Tesla coil was invented by Nikola Tesla (1856-1943) around 1891. A concise history leading up to the invention can be found for example in [95]. Today Tesla coils are used for entertainment, to show the effects of high voltage and frequency, but also as vacuum system leak detectors. Our Tesla coil in the show was built by Timo Poller, a Bonn physics student, and produces about 200,000 V output voltage, see Figs. 18, 67, and 66.



Figure 67: Our Tesla transformer, built by Timo Poller. The gray box on the left contains the remote controls connected to the transformer via an extended cable.

A.22.2 Materials and Technical Details

A Tesla coil can be bought or built. Instructions on how to build your own can be found on YouTube at [94]. Details of our apparatus are shown in Figs. 67, and 66. It has the dimensions 300 mm x 300 mm x 800 mm. For easier transport, the secondary coil, the silver toroid, and the needle on top can be dismounted. It has a normal (230 V) power plug and the circuitry is completely based on semiconductors. The output voltage is about 200,000 V. We are happy to provide construction details upon request.

A.22.3 Presentation

The Tesla coil is used in this show to demonstrate very high voltages, specifically, we used it for comparison to the energy of the particles in the LHC, see Figs. 17, 18. The lecture hall is dimmed, and then the transformer is turned on, generating large sparks. This is also quite loud. For a brief discussion of further applications, see the following subsection.



Figure 68: Lightsaber fight using conventional fluorescent tubes wrapped in colored paper, and of course our Tesla transformer. This is from a previous show and was a fight between Yannick Edmonds as James Bond (on the right) and Erik Busley as Dr. Yes on the left. This photo was taken by Volker Lannert.

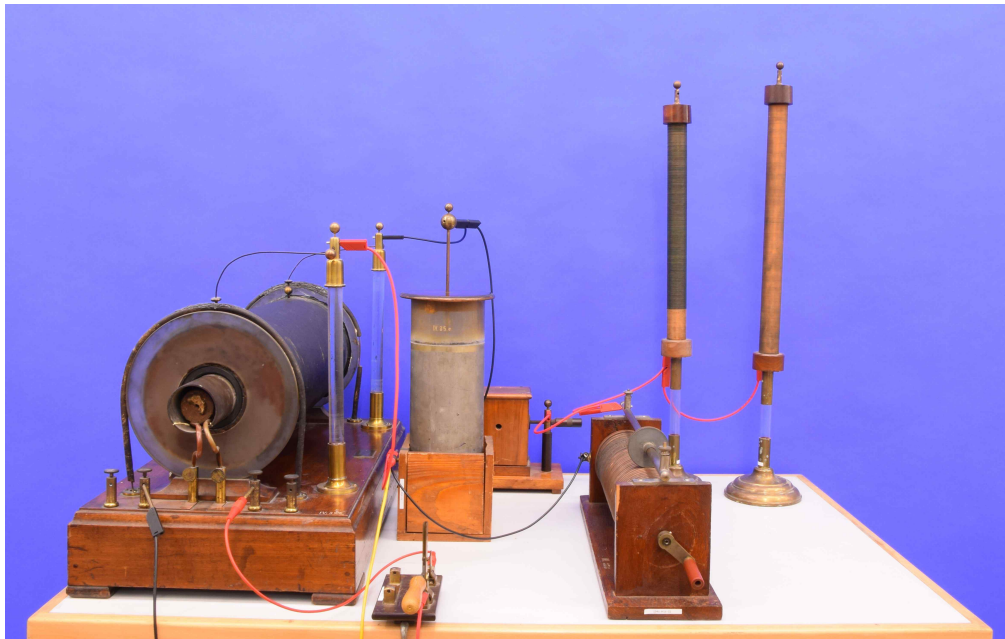

Figure 69: Tesla transformer using an old induction coil from 1858. The large horizontal cylindrical object on the left is the induction coil. The vertical cylindrical object in the middle is a Leyden jar. Just behind it the smaller wooden casing contains the spark gap. Next to the right, is a variable coil. In the back, the two vertical slender cylindrical objects are Seibt coils.

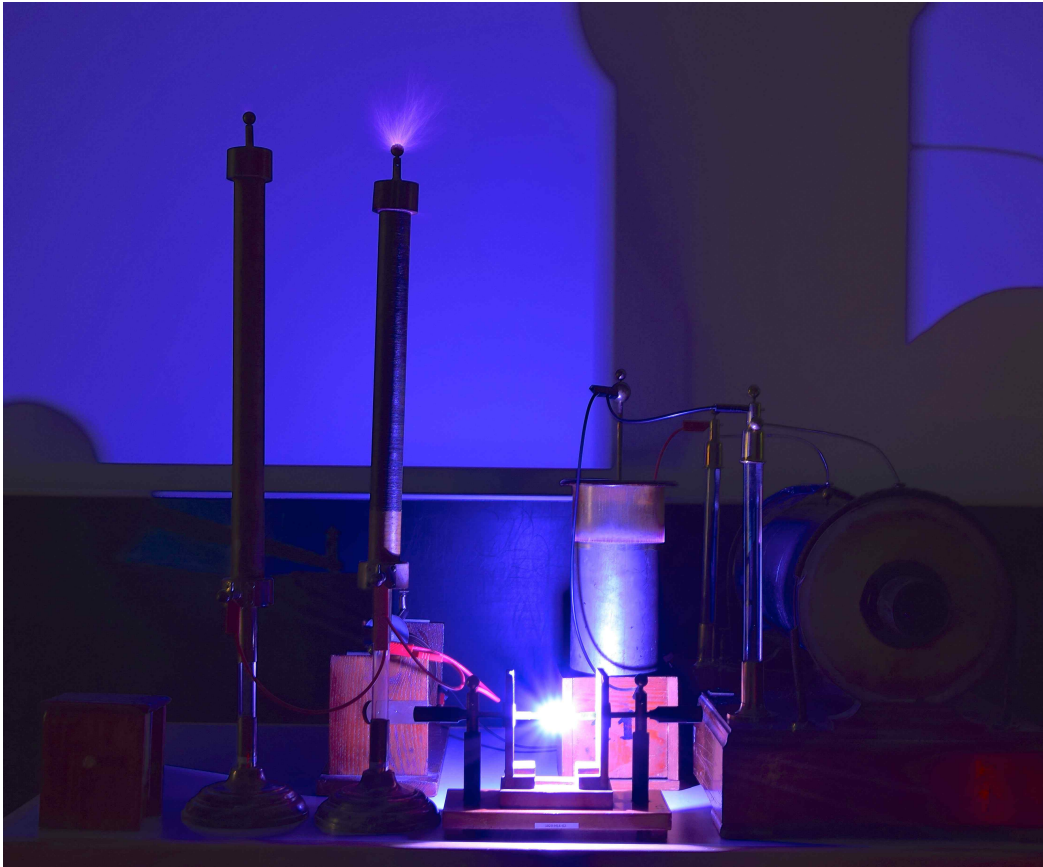

Figure 70: Old Tesla coil in action. The box has been lifted to show the spark gap. At the top is the lightning discharge of one of the Seibt'sche coils.

A.22.4 Extensions

The strong electromagnetic fields surrounding the Tesla coil can be demonstrated for example using fluorescent tubes, see Fig. 68. In the case of the lightsaber fight we often accompany this with the Star Wars sound track. This is very popular with the audience, but would have been too much of a distraction during the introduction of the LHC in the particle physics show. Also music, *e.g.* from a guitar or from an electronic source, can be transmitted via the Tesla sparks.

In Bonn we also have a nice (robust!) historical one with an induction coil from 1858, see Figs. 69, 70, 71, which we have mainly used in local shows, not when travelling.

A.22.5 Safety

Since the Tesla coil produces high electrical fields great care must be taken. For example pacemakers (and other electronic equipment) can be damaged, and audience members who have one should retreat to the back of the auditorium. Furthermore for this specific Tesla transformer the lower part containing the circuits is not encased to allow for better cooling. During operation a larger distance should be maintained, and the circuits should not be touched. The discharges at the top should also not be touched in anyway, for this larger Tesla transformer, as the field strengths are too large.

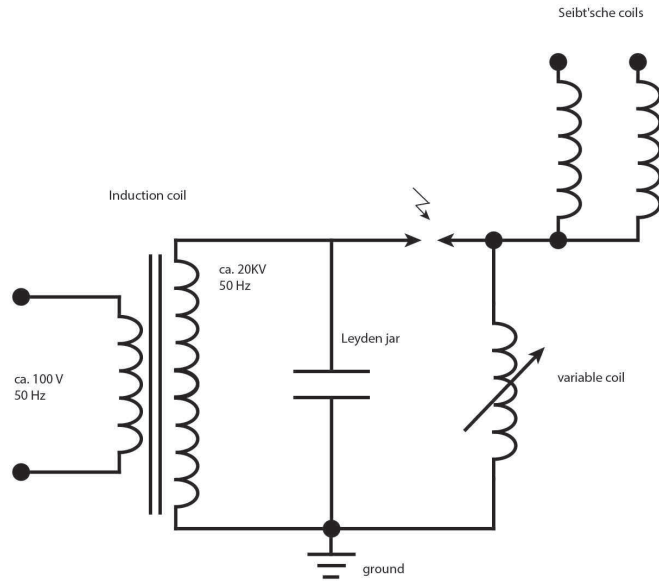

Figure 71: Circuit drawing for the setup in Figs.69, 70.

A.23 Tossing Balls: a Collider Onstage

This experiment consists of two plastic boxes each filled with the small colored plastic balls which are usually found in children's ball pits. It is performed by two people standing a few meters apart. For the first trial, each one each picks a single ball. They throw these two balls towards each other and usually, no matter how times they try, the two balls do not meet. For the second trial the entire boxes of balls are thrown. Subsequently, there are almost always at least a few collisions. The principle behind the experiment is to demonstrate why at colliders we do not try to collide single particles, but rather bunches of particles.

A.23.1 History

We first saw this analogy used for a collider physics experiment in a science slam performed by Klaus Desch in Bonn on Nov. 23rd, 2011. However he used small wooden crates of mandarins. We thought this would be too messy in Padua. We are not aware of any other usage.

A.23.2 Materials

Two boxes with approximately 50 plastic balls each in 2 colours. The two boxes should contain different colors, so that the effect is more easily seen.

A.23.3 Technical Details

For the balls, we ordered ball pit balls for children. The ones we used have a diameter of 54 mm. The size of the box should be such that they are easy to carry and lift.

A.23.4 Presentation

The two protagonists are standing in the LHC ring at CERN and trying to understand what happens at the LHC, as has been explained above. Each of them takes a ball,

they turn towards each other a few meters apart and then count down from 3. At 0 both throw the ball and, despite their best efforts, the balls pass by each other, as can be seen in Fig. 19.

They give it a second try, but quickly realize that this strategy doesn't work. Confused, they ask how this is done at the LHC. The answer is that the LHC applies a smarter concept. Instead of single balls, *i.e.* single protons, bunches of protons are propelled at each other. The two time travellers want to try that as well and the caretaker hands them each a box full of balls, symbolizing two bunches of protons. They count down, again from 3, and throw the balls all at once, as can be seen in Fig. 20.

This time many balls collide and the result is a beautiful pattern of coloured balls on the stage floor. Afterwards the audience is asked whether this time they saw collisions; as is to be expected, the majority answer that they did indeed see at least one collision.

A.23.5 Safety

People can slip and fall on the balls onstage. In our show the Caretaker sweeps them aside to avoid this eventuality.

A.24 Visualizing the Electric Vector Field

This is not a real experiment, it is more of a visual aid to introduce the abstract concept of a field, in this case a vector field. This is in contrast to the later introduced scalar field, the Higgs boson being a scalar field. The important point is that when a test charge is placed in a field it obtains a property. In the case of a vector field this property has a magnitude *and* a direction.

A.24.1 History

To the best of our knowledge this experiment was first used by HKD during his Science Slam in the Jakobshof, in Aachen, Germany, on January 16th, 2013 [96].¹⁷ We do not know of any previous instances of this experiment.

A.24.2 Materials

To demonstrate the electric charges we used seven A4 charts in total for our presentation. These charts have + and – signs printed on them depending on which charge they represent. The charts were laminated to allow for frequent usage. The charts looked as follows:

- One chart with one + on the front and one – sign on the backside. These are the test charges.
- Two charts, each with one + on it, and a third chart with many + signs on it.
- Two charts, each with one – on it, and a third chart with many – signs on it.

¹⁷Worst restrooms, ever.

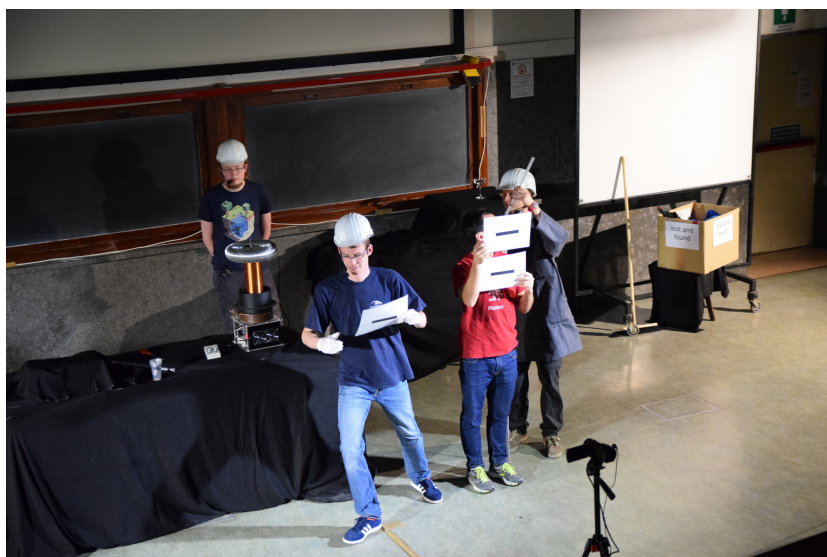

Figure 72: TL as the test charge, repelled by LU with the double-negative charge. In the background, at the blackboard, CSch. Just behind LU, the Caretaker, JSchm.

A.24.3 Presentation

The presentation is geared up for the joke at the end, where the test charge flips sign rapidly. So this involves some acting skills and careful timing. Patience is required.

For this demonstration we need three people. In our show these were the two main characters, MH and LU, as well as one of the CERN scientists, here TL. MH and LU stand a few meters apart and each of them has a sign with a single charge on it displayed to the audience, MH a plus and LU a minus sign, see Fig. 22. Previously, via the projector a “Faraday” slide of the electric vector field with field lines between two opposite point charges was shown, see Fig. 23. Hopefully some members of the audience have seen this in their school days. Thus this is a reenactment of that picture, with the field lines missing.

TL has the sign with a + on one side and a - on the other, he represents the test charge, which is placed in the static electric field, created by the two time travellers. The scientist steps between the other two, holding up his sign, let’s say -. He is then attracted to MH, who is holding the + and repulsed by LU, who is holding a -. After stating this point, he strides to MH. Here it is essential to stress the conceptual point; by being placed *in* a *vector* field he receives a property (potential energy), *and* a direction, the momentum of his motion.

When the scientist with the probe charge reaches MH with the oppositely charged source charge, he flips his sign by flipping his chart. He is thus now attracted to LU, the other source charge, and repulsed by MH. He thus strides over to LU.

Now LU and MH double their charges and then TL once again flips his charge. He is now attracted more strongly to MH and thus runs over to her. After flipping his charge he runs back to LU.

Finally, LU and MH dramatically increase their charges, see the photo on the right in Fig. 23. TL demands close attention of the audience, goes into a starting position as for a race, and then quickly flips his sign back and forth. Slightly out of breath, he emphasizes that he has moved so quickly, that the audience wasn’t even able to see him move.

A.25 Scalar Field: Analogy

This is an extension of the previous experiment on the vector field, described in App. A.24. The main point is when you place an object in a scalar field it takes on a property, in our case temperature, but *no* direction.

A.25.1 Materials

This requires a slide showing a weather map with temperatures, in our case Italy, see Fig. 24, and one glass of water.

A.25.2 Presentation

The presenter takes a glass of water and asks the audience to imagine placing this at various places on the map. It obviously acquires the local temperature, but no direction. The important point then is that when you place an object in the background Higgs-field, it also acquires a property, namely mass. The stronger the interaction with the Higgs field the larger the mass.

A.26 Visualizing the Scalar Higgs Field

This experiment creates a visualization of the Higgs field and the mechanism through which particles interact with that field and therefore acquire mass. A large cloth is used to represent the Higgs field and the movement of objects of different weights through the swinging cloth helps create a tangible metaphor for the motion of particles of different mass.

A.26.1 History

The idea for this experiment originated from a Science Slam in Aachen [96] by HKD.

A.26.2 Materials and Technical Details

We use a large cloth of 2.50 m×1.40 m, which represents the background Higgs field. We use a large plush-owl as a heavy particle, a small plush-sheep as an electron, a light particle, a big-fat green plush-frog to represent the Higgs boson, and two hammers to excite the Higgs field.

A.26.3 Presentation

Two people grab each one end of the cloth and start swinging it slowly up and down to represent the fluctuating Higgs field, Fig. 73. While in principle swinging the cloth is simple, doing so with the right strength and frequency takes a bit of practice. When one of our two volunteers inevitably gets tired the moderator throws in a quick joke about the Higgs field's eternal nature and mentions that it NEVER stops.

To investigate the interaction of particles with the Higgs field we begin by throwing in either a ping-pong ball or, as is shown in Fig. 25, a tiny plush sheep.

Since the object is very light, if the two people swing the cloth properly it jumps from side to side with a very high frequency. In terms of our analogy, the particle is barely interacting with the field and is capable of moving through space quickly. A small weakness of the experiment is that the motion of the object stems from the motion of



Figure 73: The swinging cloth in the image represents our fluctuating Higgs Field. One CERN scientist, TL, is about to throw in the small plush-sheep.

the cloth. In reality the Higgs field does not provide particles with their momentum. The small toy corresponds to a light particle, like an electron, whose low interaction with the Higgs field corresponds to a low mass.

Next, a larger toy is thrown into the cloth. While the field continues billowing, the heavy object barely jumps and moves very slowly or not at all through the cloth. In our case we chose to use a toy owl, which corresponds a heavy particle like the top quark. The particles weight comes from its heavy interactions with the Higgs field that causes it to move slowly through it.

We conclude the experiment by offering an explanation of the Higgs boson itself. It is said that the Higgs boson can be understood as the result of an excitation of the Higgs field. In order to “excite” the field onstage, one of the scientists takes two hammers to “hit” the Higgs field strongly. He counts down from three and finally smashes the hammers onto each other with the cloth in between. In this instant, someone hidden somewhere onstage throws another rather heavy plush animal or ball into the field. In our case we used a green frog, as can be seen in Fig. 74. The two members swing the cloth so that the Higgs boson flies out and lands in the arms of the moderator. He explains that the Higgs boson is produced by the exciting the Higgs field and continues the story by asking how such an excitation is produced at the LHC.

A.26.4 Safety

The only real safety concern is the use of the hammers. The moderator should be careful not to hit themselves.

A.27 The Higgs Mechanism and Eddy Currents: an Analogy

For this experiment we use an aluminum tube as shown in Fig. 75, together with a brass bolt as well as a strong neodymium magnet. This is a well-known experiment, which is



Figure 74: Higgs boson being dropped out of the Higgs field after it was excited by the smashing of two hammers. One CERN scientist, CSch, is holding one of the hammers in his right hand. The cloth is being billowed by MBr and JSch-R.

often used to show the effect of eddy currents. It can be performed also with a much larger tube, and larger magnets. In our group, it was EP's idea to use this experiment as an analogy for the Higgs mechanism.

A.27.1 Technical Details

The aluminum tube we use is 440 mm long, has an inner diameter of 16 mm and an outer diameter of 20 mm. We use a simple metal bolt which is made of brass (non-magnetic) and has a diameter of 15 mm and a height of also 15 mm. The magnet is the same size: 15 mm high and 15 mm in diameter.

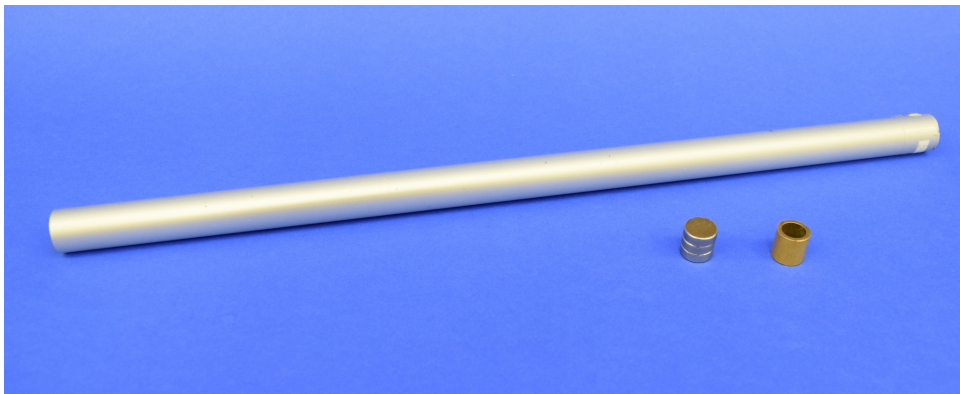

Figure 75: Materials for the eddy-current Higgs analogy experiment. The aluminum tube is 440 mm long.

A.27.2 Presentation

The main point of this experiment within the show is the analogy with the Higgs mechanism. After spontaneous symmetry breaking the lowest energy configuration for the Higgs field has a constant background value everywhere in space and time. By being placed in this background field, particles obtain mass. The stronger they couple to the Higgs field, the larger the mass. In our experiment, the background Higgs field is symbolized by the aluminum tube. We hold the aluminum tube vertically in one hand. Below the lower opening we place a plastic cup. This collects the pieces as they drop through, with a distinctly audible “plonk”. Next we take a permanent magnet and lift a key. Then with this permanent magnet we show that the aluminum tube is not magnetic.

For the experiment we first take the brass bolt. This represents a massless particle which does not interact with the Higgs field, which in our physical representation means it does not interact with the aluminum tube. We drop this bolt into the tube. It flies straight through and drops into the cup. In our analogy, this is a massless particle which flies at the speed of light, unhindered by our representation of the Higgs field, the aluminum tube.

Next we drop the neodymium magnet into the tube. Due to the eddy currents, it falls very slowly. In our case it takes several seconds to fall into the cup. In our analogy the magnet represents a massive particle, for example an electron. It interacts with the aluminum tube, our representation of the Higgs field, and therefore it can not fly at the speed of light; instead it falls very slowly.

A.28 Light-Suits and Higgs Collision

In this experiment five people represent different particles wearing differently coloured light-suits, where the lights can be turned on and off. They perform a choreography meant to mimic a Higgs-production from two colliding protons.

A.28.1 History

Light-suits are very popular in various artistic performances, with many examples on YouTube.

A.28.2 Materials and Technical Details

For this experiment we used five black overalls. To these we attached LED strips of various colors. The LED strips run on 12V/DC. Each package is 5m and we used about 8m per overall. The LED system we used was extendable. To supply the LED strips with electric power we provided each suit with eight AA rechargeable batteries, a battery holder for parallel connection, thin wire, and a switch. This gives the person in the suit control of the light. In the show, as an additional visual effect, we use two yellow flashing warning lights which indicate the activated accelerator.

We decided to show the decay of the Higgs boson into two photons, therefore we have two white light-suits representing protons, two blue light-suits for photons, and a green light-suit for the Higgs boson, see Fig. 76. For each suit the LED strip was cut into four pieces, and wound up around the arms and legs of the overall. It is best to fix the LED strip to the overall by using small pieces of hook-and-loop tape. For the power supply, each LED strip is connected with the battery holder in one of the pockets of the

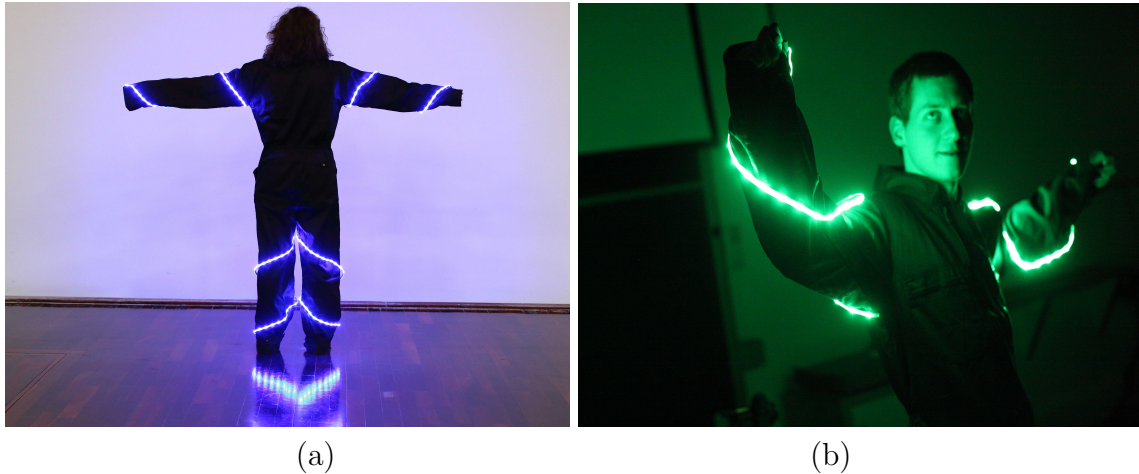

Figure 76: (a) One of the blue light suits, representing a photon. (b) A close-up of the green light suit for the Higgs boson, with MKr.

overall. The circuit has a switch that controls all lights on a given suit. The switch is connected with a long wire such that it can be placed at the end of the sleeve. The five suits available to us were mainly sewed and assembled by Dagmar Faßbender and MKo.

A.28.3 Presentation

Onstage the flashing yellow lights are switched on and the moderator warns that the accelerator has been turned on. The people onstage escape, while pointing out that the audience has to stay.

When the stage gets dark the five people in the light-suits, which are switched off, enter the stage. The Higgs boson and the two photons place themselves kneeling in the center of the stage, where the Higgs is about 1.5 m away from the photons. The protons place themselves at the extreme left and right ends of the stage. Some form of dance music starts, the protons light up and move towards each other. In the first approach they miss and go to the opposite edge of the stage where they turn off their lights again for a short time. They re-light, approach again and this time “collide”, right next to the Higgs boson. While the protons kneel down and turn off their lights, the Higgs boson stands and lights up. It moves slowly towards the position of the photons and is flashing using the switch, indicating instability. When the Higgs boson approaches the photons it decays and the person kneels down and switches of the light. Now the photons light up and move quickly along two corridors through the audience to the back of the hall.

The reaction is explained after the first performance. Everything is rewound by the Caretaker, who can control time. All the particles perform the reaction backward but a bit faster. When the Higgs is backing up we play the warning beeping sound that trucks and vans use. We play the sound of a music tape being rewound for the other particles. Then the performance is repeated more slowly and explained by the Caretaker. This last experiment marks the end of the show.

A.28.4 Safety

The performance requires a lot of space and a dark stage, which should be free of anything people can trip over. Special attention is needed since, due to a previous experiment, small plastic balls can still be scattered onstage.

References

- [1] For an original Italian version see for example: “Dialogo sopra i due massimi sistemi del mondo”, Galilei Galileo, BUR Biblioteca Univ. Rizzoli (4 giugno 2008). For an English edition see for example: “Dialogue Concerning the Two Chief World Systems”, Galileo Galilei, Modern Library Inc; New edition (2 Nov. 2001).
- [2] The webpage of the Royal Institution is: <http://www.rigb.org/>. They have the wonderful subtitle: “Science lives here”.
- [3] J. Butterworth, “Smashing physics : Inside the world’s biggest experiment,” Headline Publisher, (22 May 2014).
- [4] See the webpage of the Deutsches Museum: <http://www.deutsches-museum.de/kontakt/>.
- [5] See the webpage of the Science Museum, London: www.sciencemuseum.org.uk.
- [6] See the webpage of the Museum of Science and Industry, Chicago: www.msichicago.org.
- [7] See the webpage of the Exploratorium, San Francisco: www.exploratorium.edu.
- [8] G. Aad *et al.* [ATLAS Collaboration], “Observation of a new particle in the search for the Standard Model Higgs boson with the ATLAS detector at the LHC,” *Phys. Lett. B* **716**, 1 (2012) [arXiv:1207.7214 [hep-ex]].
- [9] S. Chatrchyan *et al.* [CMS Collaboration], “Observation of a new boson at a mass of 125 GeV with the CMS experiment at the LHC,” *Phys. Lett. B* **716** (2012) 30 [arXiv:1207.7235 [hep-ex]].
- [10] S. Carroll, “The particle at the end of the universe : How the hunt for the Higgs boson leads us to the edge of a new world,” Plume (August 27, 2013).
- [11] L. Randall, “Higgs discovery : The power of empty space,” Ecco (September 24, 2013).
- [12] L. M. Lederman and C. T. Hill, “Beyond the God Particle,” Prometheus Books (October 8, 2013).
- [13] “Guericke, Otto von”. *Encyclopædia Britannica*, 11th Edition 9. The Encyclopædia Britannica Co. 1910. p. 670.
- [14] See for example the Webpage of the Deutsches Museum, München on the history of electricity: www.deutsches-museum.de/ausstellungen/naturwissenschaft/physik/elektrizitaet/.
- [15] A short biographical sketch of Prof. Shakhashiri can be found at: scifun.chem.wisc.edu/BZS_bio/biosketch_short.htm.
- [16] The webpage of *Science is Fun – in the Lab with Shakhashiri* can be found at: scifun.chem.wisc.edu.
- [17] C.J. Sprott, *Phys. Teach.* **29**, p.212 (1991).

- [18] *Physics Demonstrations: A Sourcebook for Teachers of Physics*, by Julien Clinton Sprott, University of Wisconsin Press, Madison, Wisconsin, ISBN-13: 978-0299304706.
- [19] The ‘Wonders of Physics’ webpage at the Physics department at the University of Wisconsin can be found at: wonders.physics.wisc.edu.
- [20] H. K. Dreiner, *Phys. Teacher* **46** (2008) 358; arXiv: [physics/0701344 [PHYSICS]].
- [21] *It’s Physikshow time in Germany*
Herbert K. Dreiner
CERN Courier 9 (2007) 30.
- [22] *Fun physics in school: students perform for students* ; Herbert K. Dreiner, and Tobias Strehlau; *Science in School* 9 (2008) 46.
- [23] *Physique? C’est tout le Français à moi*; Herbi Dreiner; *Guardian Newspaper, Life and Physics*, Sept. 22nd, 2010.
- [24] *SLAM POW BANG: On Tour in England with the Bonn Physics Show* ; Herbi Dreiner; *Guardian Newspaper, Life and Physics*, March 13th, 2014.
- [25] Homepage of Universität Göttingen on the Kamiokannen experiment: <http://kamiokanne.uni-goettingen.de>; Fuidl, M. (2003): *Kosmische Myonen in Schulversuchen*. Staatsexamensarbeit, Universität Mainz: <http://www.iph.uni-mainz.de/551.php>.
- [26] The current BMBF website on the LHC for the public is at www.weltmaschine.de. More details on the Weltmaschine exhibition can be found at www.weltmaschine.de/e5/e101.
- [27] The webpage of the DFG collaborative research center CRC 110 can be found at: crc110.hiskp.uni-bonn.de.
- [28] A full length video of the Oxford show ‘Accelerate’ can be viewed at www2.physics.ox.ac.uk/accelerate. We are not aware if this show has been performed since.
- [29] A pdf write-up of the experiments in the Oxford ‘Accelerate’ show can be found at www2.physics.ox.ac.uk/sites/default/files/2012-04-24/accelerate_cheatsheets_all_89230.pdf.
- [30] An MIT YouTube video of the jumping ring www.youtube.com/watch?v=4a0FbQdH3dY.
- [31] For YouTube videos of fire tornados see for example: www.youtube.com/watch?v=BGv02S8Eong.
- [32] YouTube video of natural fire tornado in Australian bush fire www.youtube.com/watch?v=lsyv0YcWgcg.
- [33] For a camp fire and box fans version of the fire tornado see for example: www.youtube.com/watch?v=0L_VUh4gzIk.
- [34] Franklin, Benjamin, “Of the stilling of Waves by means of Oil.” Letter to William Brownrigg and the Reverend Mr. Farish. London, November 7, 1773.

- [35] Masters, Barry R. “Lord Rayleigh: A Scientific Life.” Optics and Photonics News. The Optical Society, 1 June 2009.
- [36] Pockels, A., Surface Tension, Nature, 1891, 43, 437.
- [37] This image comes from the wikimedia commons and has been released to the public domain. It can be found at the following url: <http://en.wikipedia.org/wiki/File:Surfactant.jpg>.
- [38] The original design at DESY was developed by Philip Bechtle in an attempt to convince the WDR TV-show “Sendung mit der Maus” to produce an episode about elementary particle physics, Mai 2004.
- [39] Private communication: T. Zoufal.
- [40] Joseph F. Keithley, “The story of electrical and magnetic measurements: from 500 B.C. to the 1940s,” John Wiley and Sons, 1999.
- [41] A. Pais, “Inward Bound Of Matter And Forces In The Physical World,” Oxford, UK: Clarendon (1986) 666 P. New York, Usa: Oxford Univ. Pr. (1986) 666p
- [42] Plücker, Julius, ‘Gesammelte physikalische Abhandlungen’, Hrsg. v. Fr. Pockels Leipzig, Teubner, 1896 . <http://d-nb.info/367608731>.
- [43] Details on the Helmholtz coils distributed by Leybold Didactic can be found at <http://www.leybold-shop.com/physics/physics-equipment/atomic-and-nuclear-physics/physics-of-the-electron/fine-beam-tube/helmholtz-coils-with-holder-and-measuring-device-for-fine-beam-tube-555581.html> and <http://www.leybold-shop.com/fine-beam-tube-555571.html>. Leybold Didactic is based in neighboring Köln (Cologne).
- [44] Chodos, Alan. “June 1911: Invention of the Geiger Counter.” This Month in Physics History. American Physical Society, June 2012.
- [45] The German website for the Phywe cloud chamber we use is www.phywe.de/de/09046-93. An English description of the cloud chamber can be found as a pdf document at repository.phywe.de/files/produktflyer/00235-02_phy_nebelkammer_englisch.pdf. The English website for the cloud chamber is www.phywe.de/en/geraetehierarchie/physics/modern-physics/particle-physics/09046-93.
- [46] C. T. R. Wilson, “On an Expansion Apparatus for Making Visible the Tracks of Ionising Particles in Gases and Some Results Obtained by Its Use,” Proc. Roy. Soc. Lond. A **87** (1912) 595, 277.
- [47] “C.T.R. Wilson - Facts”; Nobelprize.org., Nobel Media AB 2014. Web. 21 Aug 2015. www.nobelprize.org/nobel_prizes/physics/laureates/1927/wilson-facts.html
- [48] A. Langsdorf, Phys. Rev. **49** (1936) 422; Phys. Rev. **51** (1937) 1026; Rev. Sci. Instr. **10** (1939) 91.
- [49] See also the nice review article by M. Snowden, “The Diffusion Cloud Chamber”, published in Prog. in Nuclear Physics 3, 1953, editor O.R. Frisch.

- [50] C. D. Anderson, “The Positive Electron,” *Phys. Rev.* **43** (1933) 491.
- [51] S. H. Neddermeyer and C. D. Anderson, “Note on the Nature of Cosmic Ray Particles,” *Phys. Rev.* **51** (1937) 884.
- [52] J. C. Street and E. C. Stevenson, “New Evidence for the Existence of a Particle of Mass Intermediate Between the Proton and Electron,” *Phys. Rev.* **52** (1937) 1003.
- [53] L. Leprince-Ringuet and M. L’Heritier, “Existence probable d’une particule de masse 900 m_e dans le rayonnement cosmique” (“Possible Existence Of A Particle Of Mass 990 $M(0)$ In Cosmic Radiation,” *Comptes Rendus Acad. Sciences de Paris*, séance du 13. Dec. 1944, p. 618. (The data were taken 1943 in the French Alps.)
- [54] G. D. Rochester and C. C. Butler, “Evidence for the Existence of New Unstable Elementary Particles,” *Nature* **160** (1947) 855.
- [55] T. S. Needels, and C. E. Nielsen, “A Continuously Sensitive Cloud Chamber”, *Rev. Sci. Instrum.* **21**, 976 (1950).
- [56] On how to make your own cloud chamber with dry ice, see for example: www.youtube.com/watch?v=400xfGmSlqQ.
- [57] H. Becquerel, “Sur les radiations invisibles mises par les corps phosphorescents”, *Comptes Rendus de l’Académie des sciences*. Band 122, 1896, S. 501-503.
- [58] E. Rutherford, “Uranium Radiation and the Electrical Conduction Produced by It,” *Philosophical Magazine* **47**, 109-163 (1899).
- [59] W.H. Bragg and R. Kleeman, *Phil. Mag.* **11**, 726, 1904; *ibid* **10** 318 1905.
- [60] J. Chadwick, “Intensitätsverteilung im magnetischen Spektrum von β -Strahlen von Radium B+C”. (The intensity distribution in the magnetic spectrum of beta particles from radium (B + C)) *Verh. Phys. Gesell.* **16** (1914) 383.
- [61] W. Pauli, letter to a physicists’ gathering in Tübingen, Dec. 4th, 1930, translated into English and reproduced “Dear radioactive ladies and gentlemen,” in L.M. Brown, ‘The idea of the neutrino’, *Phys. Today* **31 (9)** (1978) 23; <http://dx.doi.org/10.1063/1.2995181>.
- [62] F. Reines and C. L. Cowan, “Detection of the free neutrino,” *Phys. Rev.* **92** (1953) 830.
- [63] A. Franklin, “Are there really neutrinos? An evidential history,” Cambridge, USA: Perseus (2001) 371 p.
- [64] P. A. M. Dirac, “The Quantum theory of the electron,” *Proc. Roy. Soc. Lond. A* **117** (1928) 610.
- [65] Private communication.
- [66] For a discussion of industrial and mining dust explosions see for example en.wikipedia.org/wiki/Dust_explosion.

- [67] The PIRA resource base can be found here: physicslearning2.colorado.edu/pira/. Although it seems to be incomplete, and we could not find the vacuum cannon. Instead we found a more detailed description in [68].
- [68] Description of the vacuum cannon along PIRA standards www.physics.isu.edu/physdemos/fluids/VacuumCannon.html.
- [69] Fritz Krafft (editor), “Otto von Guericke's Neue (Sogenannte) Magdeburger Versuche über den Leeren Raum”, VDI-Buch, Springer, 1996. This is a German translation from the Latin of the original work of Otto von Guericke, written in 1672.
- [70] O. v. Guericke first describes his invention of the vacuum pump in the chapters entitled “Experimentum novum Magdeburgicum” on pp. 441-488 of Gaspar Schott's book “Mechanica Hydraulicopneumatica”, Würzburg, Germany, Henrick Pigrin, 1657.
- [71] Julius Zöllner, “Die Kräfte der Natur und ihre Benutzung: Eine physikalische Technologie”, Springer. Original copyright: 1877.
- [72] Neil A. Downie, “Vacuum Bazookas, Electric Rainbow Jelly and 27 Other Saturday Science Projects”; Princeton University Press, New Jersey, 2001, p. 70–79.
- [73] John Cockman, “Improved Vacuum Bazooka”, *The Physics Teacher*, **41** (2003)
- [74] Richard W. Peterson, Benjamin N. Pulford, and Keith R. Stein, “The Ping-Pong Cannon: A Closer Look”, *Phys. Teach.* **43**, 22 (2005).
- [75] Eric Ayers, and Louis Buchholtz, “Analysis of the Vacuum Cannon”, *American Journal of Physics* **72** (2004).
- [76] Jun Han Bae, “Analysis of the Ping-Pong Ball Gun – Theoretical & Computational Approach”, Master's Thesis, Purdue University, 2014. College of Technology Directed Projects, Paper 49. docs.lib.purdue.edu/techdirproj/49.
- [77] Michael Vollmer, Klaus-Peter Möllmann, “Otto von Guericke's Windbüchse”, *Phys. Unserer Zeit*, 1/2015 (46).
- [78] There is a discussion on Clifford Johnson's blog by a reader “karl” asymptotia.com/2010/10/04/quark-constituents.
- [79] Quark is now sold by Whole Foods in the USA www.wholefoodsmarket.com/recipes/food-guides/dairy-products.
- [80] Heinrich Hertz, “Über einen Einfluss des ultravioletten Lichtes auf die elektrische Entladung”, *Annalen der Physik und Chemie*, 267, Nr. 8, 1887, S. 983–1000.
- [81] Wilhelm Hallwachs, “Über den Einfluss des Lichtes auf electrostatisch geladene Körper”. *Annalen der Physik und Chemie*, 269, Nr. 2, 1888, S. 301-312; Wilhelm Hallwachs, “Über die Electricisirung von Metallplatten durch Bestrahlung mit electricischem Licht”, *Annalen der Physik und Chemie*, 270, Nr. 8A, 1888, S. 731-734.
- [82] A. Einstein, “Über einen die Erzeugung und Verwandlung des Lichtes betreffenden heuristischen Gesichtspunkt”, *Annalen der Physik*. 322, Nr. 6, 1905, S. 132-148.

- [83] See the website: www.kunst-und-kultur.de/index.php?Action=showMuseumExhibition&aId=6403.
- [84] Antoine Weis, R. Wynands, *Three Demonstration Experiments on the Wave and Particle Nature of Light*, Physik Didaktik in Schule und Hochschule, PhyDid 1/2 (2003) 67-73.
- [85] Todorka Lulcheva Dimitrova and Antoine Weis, *The wave-particle duality of light: A demonstration experiment*, Amer. Jour. of Physics, **76** (2008) 137.
- [86] U. Kraus, M.P. Borchers, Physik in unserer Zeit, Vol. **36**, issue 2 (2005), p.53.
- [87] U. Kraus and M. Borchers, “Fast lichtschnell durch die Stadt”, Physik in unserer Zeit 2/2005, www.tempolimit-lichtgeschwindigkeit.de/tuebingen/tuebingen.pdf.
- [88] J. Terrell, “Invisibility of the Lorentz contraction”, Phys. Rev. 1959, 116, 1041.
- [89] G. Gamow, “Mr. Tompkins in Paperback”, Cambridge University Press, Cambridge 1967.
- [90] A.Lampa, “Wie erscheint nach der Relativitätstheorie ein bewegter Stab einem ruhenden Beobachter?”, Z. Physik 1924, 72, 138.
- [91] R. Penrose, “The Apparent Shape of a Relativistically Moving Sphere”, Proc. Cambridge Phil. Soc. 1959, 55, 137.
- [92] V.F. Weisskopf, “The visual appearance of rapidly moving objects,? Physics Today pp.24-27 (Sept 1960).
- [93] A nice short film of this effect (lack of observed contraction) for the case of a sphere is given at this webpage th.physik.uni-frankfurt.de/~scherer/qmd/mpegs/lampa_terrell_penrose_info.html. For a sphere of course no rotation can be observed.
- [94] Here is an example on YouTube on how to build a Tesla coil www.youtube.com/watch?v=jjatYNucBMk.
- [95] W. Bernard Carlson, “Tesla: Inventor of the Electrical Age”, Princeton University Press; Reprint edition (April 27, 2015).
- [96] Here is a WDR recording of the science slam in Aachen an YouTube www.youtube.com/watch?v=k7oakBI2AWE.
- [97] The website of the Physikuse in Hennef is: www.physikuse.de.