



3 1761 06705796 8

LABORATORY PROJECTS  
IN PHYSICS  
GOOD







LABORATORY PROJECTS IN PHYSICS



THE MACMILLAN COMPANY

NEW YORK • BOSTON • CHICAGO • DALLAS  
ATLANTA • SAN FRANCISCO

MACMILLAN & CO., LIMITED

LONDON • BOMBAY • CALCUTTA  
MELBOURNE

THE MACMILLAN CO. OF CANADA, LTD.

TORONTO

G.

# LABORATORY PROJECTS IN PHYSICS

A MANUAL OF PRACTICAL EXPERI-  
MENTS FOR BEGINNERS

BY

FREDERICK F. <sup>Foreman</sup> GOOD, A. M.

INSTRUCTOR IN THE SCHOOL OF PRACTICAL ARTS  
AND IN THE SCHOOL OF EDUCATION  
COLUMBIA UNIVERSITY  
NEW YORK CITY

*Illustrations by B. F. Williamson*

174257.  
5.10.22.

New York

THE MACMILLAN COMPANY

1921

*All rights reserved*

COPYRIGHT, 1920,  
By THE MACMILLAN COMPANY.

---

Set up and electrotyped. Published October, 1920.

Norwood Press  
J. S. Cushing Co. — Berwick & Smith Co.  
Norwood, Mass., U.S.A.



## PREFACE

THESE experiments have been organized for the purpose of giving concrete expression, in the field of physics, to the recent tendencies in the teaching of science with respect to aim, subject matter, and method. The physics course in a modern high school should be organized according to the recognized function of education in a democratic society. It should include units of study which the masses of boys and girls of high school age are able to pursue with profit. It should proceed toward an organization of practical situations, activities, and phenomena, the value of which will be recognized and approved by teachers, students, parents, administrators of education, and others who are responsible for the work which boys and girls do in the high school.

It is intended that these experiments should form part of a physics course which includes class discussions and demonstrations. They were devised and used for several years in a beginners' course in practical physics. They differ from the conventional physics laboratory experiments in that they deal more directly with the mechanisms and appliances of everyday experience. The materials and procedure have been worked out in detail in order to aid the busy science teacher in the laborious task of placing practical laboratory study upon a workable basis.

A large list of projects and problems is offered. In a year's course of thirty-six to forty weeks perhaps not more than half of the ninety-five experiments can be performed. The complete list represents two years' work unless more time is assigned to laboratory study than is the custom. Obviously the purpose of so large a list is to provide for optional work, especially in Groups II-III,

to suit the individual needs, purposes, and inclinations of boys and girls of high school age.

The experiments are divided into three groups representing different types of practical work suited to varying requirements in difficulty and varying conditions in laboratory equipment.

Group I experiments require inexpensive apparatus. These experiments are designed to develop skill in assembling and in manipulation as well as to provide a fund of simple introductory exercises dealing with important practical subject matter. One complete set of apparatus for all experiments in Group I costs fifty to seventy-five dollars. A complete list of apparatus may be found in the appendix. It includes names and addresses of dealers who can supply the materials.

In the author's classes, students are required to work individually on Group I experiments for the purpose of developing self-reliance and individual skill. In Groups II-III students may work in pairs. They do not, as a rule, work in larger groups. Laboratory sections with one instructor are limited, whenever possible, to a maximum of twenty students. For a class of twenty students at least five complete sets of Group I apparatus are provided with some additional parts to replace loss due to breakage. Half of the class, Division A (ten students), work on Group I experiments; the other half, Division B (ten students), work on Group II experiments. At the next session of the laboratory work Divisions A and B alternate, Division B working on Group I and Division A working on Group II. In Groups II-III students are permitted to make their own choice of experiments. In using this scheme it is advisable that apparatus parts for several different Group I experiments be placed on a convenient center table in the laboratory.

During the year's course in laboratory work students are required to do all or nearly all the experiments in Group I and not less than fifteen experiments in Groups II-III. In general, Group III experiments are more difficult than those of Group II, requiring more laboratory practice and more preliminary study. Students

are not permitted to choose Group III experiments until the second half of the course except in cases of special ability. Students who do more work than the minimum requirement set by the teacher may receive additional credit. Approximately half as much time is required for doing a Group I experiment as for a Group II-III experiment. The time assigned for a laboratory session in this work should be not less than two consecutive forty-minute periods. In this time students are able to do, on the average, two Group I experiments or one to two Group II-III experiments. One double-period laboratory session each week is a common practice. In some schools it may be found advisable to extend this time.

In the author's laboratory, apparatus parts for Group I experiments are stored in a cabinet of numbered drawers of dimensions (inside) 4 inches high by  $4\frac{1}{2}$  inches wide by 13 inches long. A cabinet containing from twenty-four to forty-eight drawers should be provided for this purpose. An index is made showing exactly where materials may be found. Materials of this kind must be properly organized to avoid confusion and inefficiency.

Apparatus for Groups II-III may be stored in cabinets located at the sides of the laboratory, easily accessible to students. This material may be kept in a cabinet of twelve to twenty-four compartments with hinged doors. The compartments are of size 18 inches wide by 21 inches high by 18 inches deep, inside measurements. For manufacturers of cabinets see apparatus list in the appendix. For convenience in locating apparatus, all cabinets must be properly numbered and indexed with the title of the experiment. Students are expected to take apparatus from the cabinets to the laboratory tables and return it in proper order to the cabinet when the experiment is finished.

The course involves the use of a workable laboratory reference shelf in connection with the experimental studies. References are made to specific books. See reference book list, page 247.

A large list of books for special study, reference, and general reading will be found in the appendix. Many of these books deal

with informational, historical, and biographical phases of science in an absorbingly interesting manner and should provide a valuable fund of supplementary reading.

The author is deeply obligated to many teachers and students of Teachers College for their coöperation and assistance. Special acknowledgment is due to Professor John F. Woodhull for his many helpful suggestions and criticisms and to the following men who assisted with the details of organization and instruction: Mr. George D. von Hofe, Mr. George Schantin, Mr. Donald H. Wilson, Mr. Morris Meister, Mr. John Bryan, Mr. Simon Brandstadter, and Mr. Murray J. Etkin. The following individuals contributed generously either in reading the manuscript or in testing the experiments with their classes: Dr. Otis W. Caldwell, Director of the Lincoln School; Professor May B. van Arsdale of Teachers College; Mr. Roland H. Williams, formerly of the Horace Mann School for Boys, now of the Scarborough School; Mr. Alton I. Lockhart of the Horace Mann School for Girls; Mr. Arthur L. Yoder of the Richmond Hill High School, Brooklyn; Miss Mabel T. Rogers of the Georgia Normal and Industrial College; and Mr. C. N. Adkisson of the Texas College of Industrial Arts. The author is especially indebted to Mr. Raymond B. Brownlee of the Stuyvesant High School, New York City, for his careful reading of the manuscript and for many valuable suggestions.

## DIRECTIONS FOR STUDENTS

At the first laboratory session the class will be divided into two sections. Section A will work on Group I experiments, and Section B on Group II experiments. At the next laboratory session the sections will alternate, Section B working on Group I experiments and Section A on Group II, etc. The apparatus required for Group I experiments will be found in boxes on a laboratory table. For Groups II-III experiments the apparatus will be found in cabinets unless other provision for storing this material is made.

Students should work individually on Group I experiments. Much of the value to be gained from this study will depend upon whether you can improve your ability to put mechanical parts together, make them work, understand what the different parts do, find out what is wrong if they do not work properly, correct the trouble, and learn the principles of their operation. Before beginning an experiment read the directions carefully. Examine the illustrations and, if necessary, the model of the apparatus made by the teacher. Note the special positions of clamps and rings in holding glassware to avoid breaking. Then proceed to the apparatus table, get the necessary parts, set up your own apparatus, and make it work properly. When each experiment is finished, you are expected to disassemble the apparatus and place the parts in the proper boxes. Your place at the laboratory tables should always be left in good order.

In doing experiments from Groups II-III, students may work in pairs (not in larger groups). In general, experiments from Group III are more difficult and should not be selected till the second

half of the course. When you have selected an experiment, write its title with your name on a slip of paper and have the instructor approve the slip. This entitles you to the use of the apparatus. If any of the required materials are not found in the proper cabinet, write the names of the articles needed on your "approval slip" and give it to the instructor. He will then give you the apparatus. When the experiment is finished, return the special apparatus *personally* to the instructor and get your "approval slip" from him as a receipt for its return.

For directions regarding laboratory reports see page 1.

## CONTENTS

	PAGE
<b>GROUP I. EXPERIMENTS</b>	
1. The Lift Pump . . . . .	2
2. The Force Pump . . . . .	4
3. The Pendulum . . . . .	6
4. The Clock . . . . .	8
5. Measuring Liquid Pressures . . . . .	11
6. Measuring Gas Pressure . . . . .	14
7. The Hydraulic Elevator . . . . .	16
8. Floating Bodies . . . . .	18
9. The Hydrometer . . . . .	20
10. The Siphon . . . . .	22
11. The Siphon Fountain . . . . .	24
12. Pressure Tank Water Supply — Boyle's Law . . . . .	25
13. Faucet Water Pressure — Boyle's Law . . . . .	28
14. Steam Heating System . . . . .	30
15. Heat of Condensation (or Vaporization) — Latent Heat . . . . .	33
16. Hot Water Heating System . . . . .	36
17. Heat of Fusion — Latent Heat . . . . .	38
18. Kitchen Hot Water Tank . . . . .	41
19. The Liquid Cell and the Dry Cell . . . . .	43
20. Measuring Electric Current . . . . .	46
21. Electric Light and Power . . . . .	48
22. Electromagnets and Permanent Magnets . . . . .	51
23. The Electric Bell and the Telegraph . . . . .	53
24. Electroplating . . . . .	55
25. Pin-hole Images . . . . .	58
26. Lens Images . . . . .	60
27. Law of Reflection . . . . .	62
28. The Law of Intensity . . . . .	64
29. The Prism and the Lens—Refraction . . . . .	66
30. The Glass Cube and the Lens — Refraction . . . . .	69
31. Illumination and Lighting . . . . .	72
32. Candle-power and Foot-candles . . . . .	74

	PAGE
33. Color . . . . .	76
34. Absorption and Lighting . . . . .	78
35. Tuning Fork and Vibrating Air Column . . . . .	80
36. The Vibrating String . . . . .	83

## GROUP II. EXPERIMENTS

37. Blood Pressure . . . . .	86
38. The Camera — A . . . . .	89
39. Electric Motor — A . . . . .	92
40. The Fireless Cooker — Insulators . . . . .	95
41. The Gas Stove Burner . . . . .	98
42. Gasoline Engine — A . . . . .	100
43. Heating a Room — Cost — A . . . . .	103
44. Heating a Room — Cost — B . . . . .	105
45. House Gas Supply — City Gas . . . . .	107
46. House Water Supply . . . . .	110
47. The Dew Point . . . . .	112
48. The Jack Screw . . . . .	114
49. The Kerosene Stove . . . . .	116
50. Levers and Scales . . . . .	118
51. The Microscope — Simple and Compound . . . . .	121
52. The Optical Disk . . . . .	125
53. The Pressure Cooker . . . . .	127
54. The Phonograph — A . . . . .	129
55. Projection Lantern — A . . . . .	133
56. The Pulley . . . . .	135
57. The Pump — Kitchen Lift Pump . . . . .	137
58. Saucepan Conduction . . . . .	139
59. Sewing Machine — A . . . . .	140
60. Water Motor — A . . . . .	143

## GROUP III. EXPERIMENTS

61. Alternating Currents . . . . .	145
62. Camera — B . . . . .	148
63. Camera — C . . . . .	150
64. The Electric Disk Stove . . . . .	154
65. The Electric Generator (Dynamo) . . . . .	156
66. The Electric Immersion Heater . . . . .	158
67. Electric Motor — B . . . . .	160



	PAGE
68. Gasoline Engine — B . . . . .	163
69. Horse Power — A — Electric Motor . . . . .	164
70. Horse Power — B . . . . .	167
71. Humidity — A . . . . .	168
72. Humidity — B . . . . .	170
73. Phonograph — B . . . . .	173
74. Projection Lantern — B . . . . .	175
75. Rheostat and Electrical Resistance . . . . .	177
76. Sewing Machine — B . . . . .	179
77. The Steam Engine . . . . .	182
78. Telephone — A . . . . .	185
79. Telephone — B . . . . .	187
80. The Telescope . . . . .	190
81. The Thermometer . . . . .	194
82. The Vacuum Cleaner . . . . .	198
83. Water Heater — Gas . . . . .	200
84. Water Motor — B . . . . .	203
85. Wireless — A . . . . .	206
86. Wireless — B . . . . .	210

## AUTOMOBILE WORK

87. Carburetor — A . . . . .	216
88. Carburetor — B . . . . .	219
89. Ford Engine — A . . . . .	222
90. Ford Engine — B . . . . .	227
91. Ignition Systems — A — Simple . . . . .	230
92. Ignition Systems — B . . . . .	232
93. Ignition Systems — C, Ford Ignition . . . . .	235
94. Storage Battery — A . . . . .	240
95. Storage Battery — B . . . . .	243

## APPENDIX

Laboratory Reference Shelf . . . . .	247
Books for Reference and Reading . . . . .	248
Apparatus List . . . . .	253
Cabinets for Apparatus . . . . .	267
Electric Wiring for the Laboratory . . . . .	267



# LABORATORY PROJECTS IN PHYSICS

---

## GROUP I. EXPERIMENTS

A CAREFUL record of each experiment that is performed should be kept in a laboratory notebook (loose leaf). Write the title of the experiment, your name, and the date at the top of each report. Answer questions in complete sentences, make diagrams, and record data and explanations according to the numbering in the directions. Make diagrams of apparatus whenever possible. They will help you to understand and remember the important facts of the experiment. Your laboratory report should show to the instructor at a glance whether or not you understood what you were doing. It should also help you to review the experiment for a test with the least loss of time.

Laboratory reports should be handed in at the next period after the experiment is completed. If you have extra time during the laboratory period, it should be spent in writing up reports, in doing reference work, or in planning for the next experiment.

Furthur suggestions relating to the organization of class procedure and to the emphasis upon fundamental mechanical skills will be found under Directions to Students, page x.

## I. THE LIFT PUMP

To construct a lift pump and explain its action.

**MATERIALS.** No. 50 Macbeth chimney; 12-oz. bottle; 12-in., solid brass piston rod, diameter 6 mm., with cotter pins; 12-in. glass tube, outside diameter 7 mm.; No. 7 one-hole stopper; No. 6 two-hole stopper (one hole at center); thin leather sheeting and tacks.

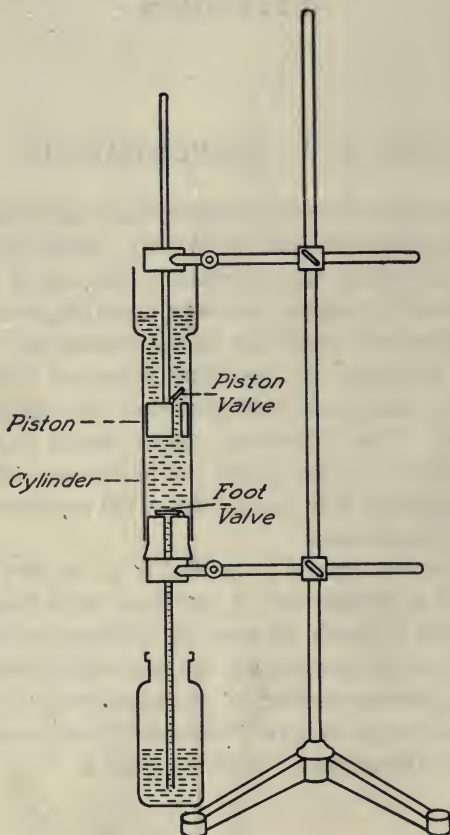

FIG. 1. — A lift pump.

**The Lift Pump.** Fit stoppers into the glass cylinders to construct a lift pump. See model made by the instructor. (*Caution. Do not clamp the sides of a glass chimney, as it is easily broken.*) Special care should be exercised in fitting the piston and in making the valves. The piston should move easily inside the cylinder when wet. It should not be so loose as to allow leakage. Make the leather valves large enough to completely cover the passageways. The valves should be fastened with ordinary carpet tacks. When parts are properly fitted, test the apparatus for lifting water. It may be necessary to pour a little water into the upper part of the cylinder.

1. Describe the action of the valves. What is the function of the foot valve? the piston valve?

2. What causes the water to rise from the cistern when the piston is raised? Refer to texts under pumps. See Black and Davis.

3. What is meant by the statement that a pump sucks water? Is this expression a correct one?

4. Can you explain why the pump works better after water reaches the cylinder?

5. What is meant by priming an old pump? See Carhart and Chute.

6. Why must the piston valve in a lift pump be less than 34 feet above the water surface? See any textbook. Refer to pumps.

7. Make two diagrams, one showing the position of the valves as the piston goes up and one as the piston goes down.

8. Name four different kinds of pumps and state what each is used for. Refer to textbooks.

The action of this pump is similar to that of the kitchen lift pump, Experiment No. 57. Examine the parts of this pump if the apparatus is in the laboratory.

**BOOKS FOR SPECIAL STUDY:**

*General Science* — Barber.

*Home Water Works* — Lynde.

*Household Physics* — Butler.

## 2. THE FORCE PUMP

To construct a force pump and explain its action.

**MATERIALS.** Chimney; 3 bottles; brass rod; glass tube 12-in.; 3 glass tubes 4-in.; nozzle tube 4-in.; No. 6 stopper, one-hole; 2 No. 7 stoppers, two-holes; leather sheeting and tacks; rubber tubing, 2 pieces, 12 in.

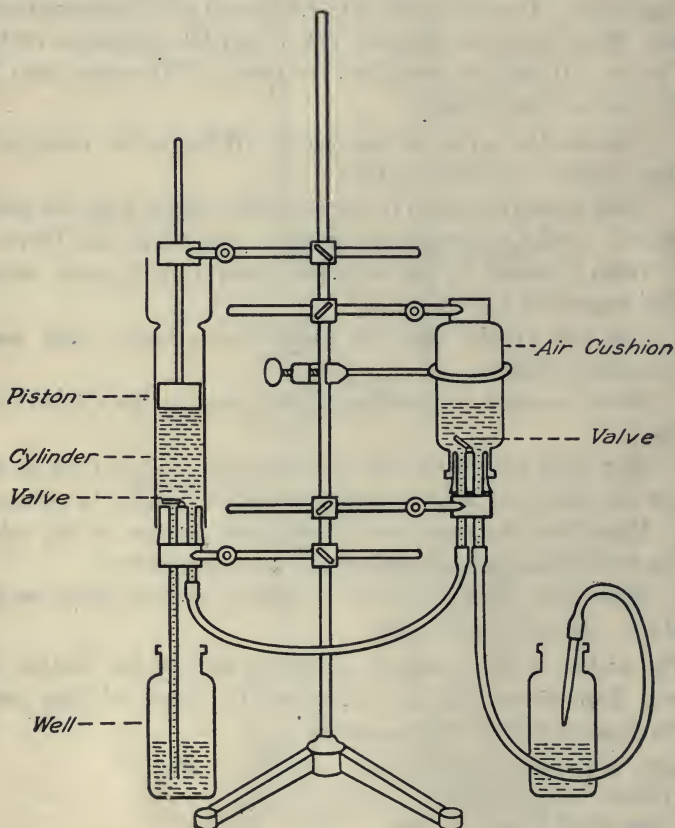

FIG. 2. — An air cushion force pump.

**The Force Pump.** Make an air-chamber force pump, using a twelve-ounce bottle for the air chamber. See instructor's model. After fitting all stoppers firmly to withstand pressure, support the apparatus on a ring stand and operate as a force pump. Note carefully how clamps and rings are placed to hold the cylinder and to prevent the stoppers from blowing out of the air chamber.

1. What proof have you that the air in the bottle acts as a cushion? Air cushions are frequently used on water pipes to protect them from sudden pressure strains.

2. What effect has the air cushion upon the flow of the water? Fire engines and large pumps employ large metallic domes for this purpose. Faucets are sometimes equipped with small air cushions to prevent hammering in the pipe when the faucet closes suddenly. An air cushion also forms part of the construction of a hydraulic ram.

3. How does the piston of the force pump differ from that of the lift pump?

4. What causes the water to flow steadily from the delivery nozzle?

5. Make a diagram of this force pump, showing the position of the valves as the piston goes up.

6. Mention one practical situation in which a force pump would be used.

7. What type of pump is used on fire engines? See Black and Davis.

8. Is the human heart a "suction" pump or a force pump? Explain by a diagram. See *Household Physics* — Butler.

**BOOKS FOR SPECIAL STUDY:**

*General Science* — Barber.

*Physics* — Black and Davis.

*Home Water Works* — Lynde.

## 3. THE PENDULUM

To study the action of pendulums.

MATERIALS. Thread and bobs; yardstick; ring stand; alarm clock.

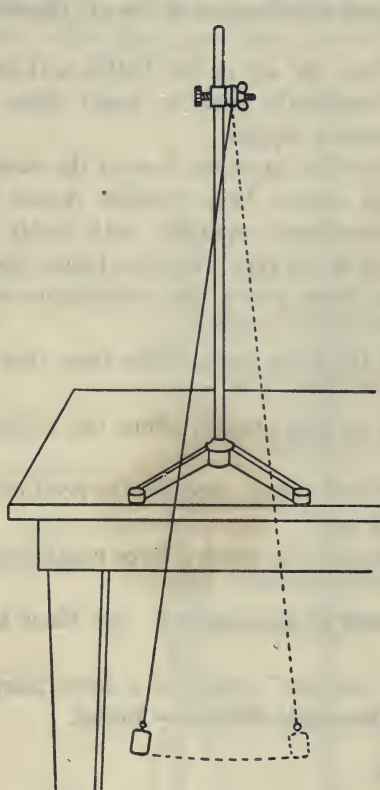

FIG. 3a. — A pendulum.

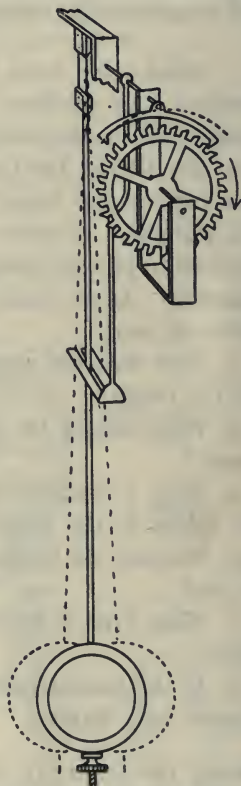

FIG. 3b. — Clock escapement with pendulum.

**The Pendulum.** Suspend a weight from a ringstand at the edge of a table by a thread four feet long. Measure from the



point of suspension to the center of the weight. Allow it to swing through a small arc of about three inches and count the number of vibrations per minute. (Count over and back as one vibration.) Repeat with a large arc (wider swing).

1. How does varying the amplitude (arc) affect the number of vibrations per minute?

2. Double the weight and count the number of vibrations. (Suspend two weights side by side on one thread. Measure accurately four feet from the center of the weights to the point of support.) Does the weight of the pendulum affect the number of vibrations per minute?

3. Repeat with pendulums one fourth and one ninth as long. How does the length of the pendulum affect the number of vibrations per minute?

4. How do the number of vibrations per unit time of any two pendulums compare? See Hoadley.

5. What is a seconds pendulum? See Carhart and Chute.

As the force of gravity increases the number of vibrations per minute increases. The attraction of gravity increases slightly in the polar regions, due to the fact that the earth is not a perfect sphere. The number of vibrations is proportional to the square root of gravity. Therefore if the pull of gravity were four times as great the pendulum would vibrate twice as fast. If gravity were nine times as great the pendulum would vibrate three times as fast. If gravity were one fourth as great, the pendulum would vibrate one half as fast.

6. If a pendulum clock, running accurately in New York, were taken North, what adjustment would have to be made in order to maintain the accuracy of the timepiece?

7. The attraction of the sun is twenty-seven times as great as the attraction of the earth. If a seconds pendulum were taken from the earth to the sun, how fast would it vibrate? The square root of 27 is 5.196.

The attraction of gravity on the moon is one sixth as great as on the earth. The attraction of gravity on the planet Jupiter is two and one half times as great as on the earth.

8. If a simple pendulum clock were taken from a cold room to a warm one, how would expansion affect its rate of movement? See Millikan, Gale and Pyle. Refer to index under Pendulum, compensated.

#### BOOKS FOR SPECIAL STUDY:

*The Modern Clock* — Goodrich.

*Physics* — Millikan, Gale and Pyle.

### 4. THE CLOCK

**To construct a clock and study its mechanism.**

**MATERIALS.** Tick-tack clock set.

**The Clock.** Assemble the parts and operate the dissectible clock. There are three main parts to a clock or watch:

- a. The source of power (weight or spring).
- b. A train of wheels operated by the driving force.
- c. An agent for controlling the speed of the mechanism (pendulum or hairspring balance wheel).

Weights are used as a driving power in large clocks, springs in small clocks and watches. The advantage of the latter lies in the fact that they occupy so little space.

The escapement to which the pendulum or hairspring is attached regulates the rate at which the wheels revolve. This is accomplished by allowing a cog of the escape wheel to pass with each swing of the pendulum or by the winding or unwinding of the hairspring.

1. How may the speed of a pendulum clock be regulated?
2. How can you regulate the speed of the balance wheel of your watch?

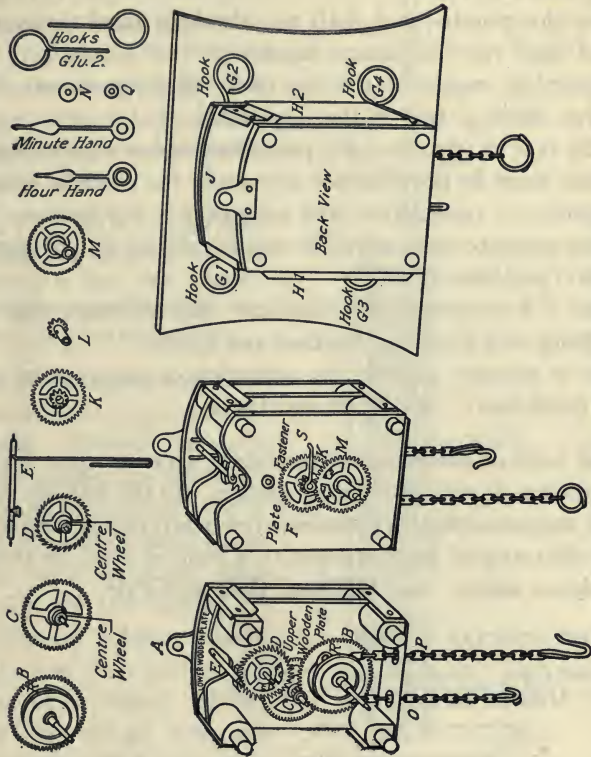

FIG. 4. — Dissectible clock mechanism.

3. Suggest a method for determining how long this clock will run with one winding. Suggestion — How many links are used up in one revolution of the large hand of the clock?

4. What is the purpose of the pendulum? See Hoadley, or Millikan, Gale and Pyle.

5. Does the minute-hand shaft run the hour hand or does the hour-hand shaft run the minute hand?

6. Explain by means of the cog teeth why the minute hand goes twelve times as fast as the hour hand.

Since the rate of vibration of a pendulum varies with its length, some means must be provided for correcting the effect of changes in temperature, — contraction, and expansion. For instance, if a clock keeps accurate time at  $70^{\circ}$ , it would run fast at  $50^{\circ}$  (pendulum shorter) and slow at  $90^{\circ}$ .

7. What is a compensated pendulum? See Millikan, Gale and Pyle, or Black and Davis, or Carhart and Chute.

8. How is mercury used in the operation of one type of compensated pendulum? See Black and Davis.

Another form of compensated pendulum depends upon the unequal expansion of rods of different metals. In the balance wheel of a watch, compensation for changes in temperature is accomplished by a very thin strip of brass screwed to a strip of steel on the rim of the balance wheel. See Millikan, Gale and Pyle.

#### BOOKS FOR SPECIAL STUDY:

*The Modern Clock* — Goodrich.

*Physics* — Millikan, Gale and Pyle.

## 5. MEASURING LIQUID PRESSURES

To determine the specific gravity of mercury and to study liquid pressures by comparing the lengths of a mercury column and the water column which it balances in a manometer tube.

**MATERIALS.** Manometer tube containing about three inches of mercury in each side; funnel; rubber connections; mercury, meter stick; two-foot glass tube.

Place the manometer in a perpendicular position. (*Caution. Handle carefully to avoid spilling the mercury.*) By means of a funnel and a rubber connection pour water slowly from a beaker into one side till the surface of one mercury column stands exactly one inch above the surface of the other. If the water does not go down on account of air bubbles, push a small wire up and down in the tube. Measure carefully in inches the length of the water column supporting or balancing this one inch of mercury.

With a rubber connection attach an additional two-foot length

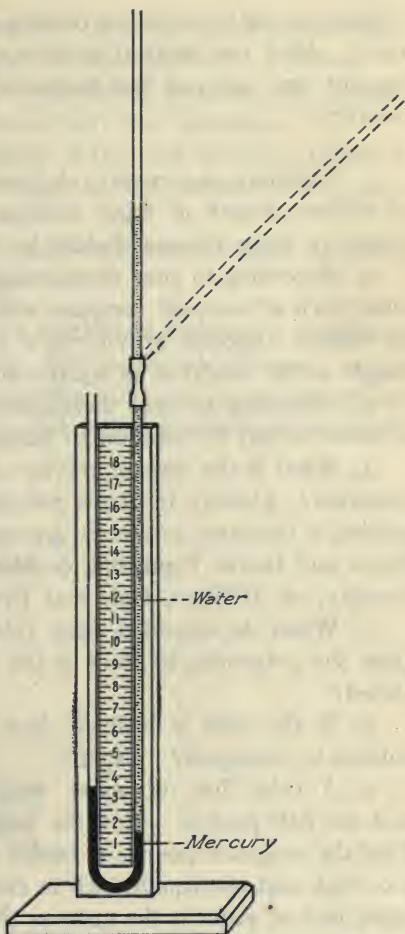

FIG. 5. — Open manometer or U-tube for determining the specific gravity of mercury and the pressure per square inch at the bottom of a water column.

of glass tubing to the water column side. Support it with a ring stand. Find the vertical lengths of water column required to support one and one half inches of mercury and two inches of mercury.

1. Tabulate the results of your measurements in columns as follows: length of water column, length of mercury column, length of water column divided by length of mercury column.

2. According to your measurements, how does the weight of a cubic inch of mercury compare with the weight of a cubic inch of water? (Specific gravity of a substance is the ratio of its weight to the weight of an equal volume of water.)

3. According to your measurements, how many cubic inches of water would be required to balance a cubic inch of mercury?

4. What is the specific gravity of mercury by accurate determination? Density in grams per cubic centimeter, in the metric system, is the same as specific gravity in the English system. See Black and Davis, Figure 58, or Mann and Twiss, Pressure and Density, or Millikan, Gale and Pyle.

5. When the extended water tube is inclined or slanted away from the perpendicular, how is the pressure on the mercury affected?

6. If the tube is inclined, how should the height of water column be measured? Explain.

7. A cubic foot of water weighs approximately sixty-two and one half pounds. Find the weight of a cubic inch of water. Find the weight in pounds of twelve cubic inches or a column one foot high and one square inch in cross section. The weight of a cubic inch of water is the same as the pressure per square inch of any water column one inch high. The weight of twelve cubic inches is the same as the pressure per square inch of any water column one foot high.

8. What pressure per square inch is exerted at the bottom of a water column fifty feet high?

9. With the specific gravity of mercury known, determine what pressure per square inch is represented by a column of mercury thirty inches high? Atmospheric pressure will support a column of mercury thirty inches high in a barometer.

10. Does the thickness or shape of the tube have any influence upon the pressure per square inch at the bottom of a liquid? Explain.

11. For any given liquid, upon what one condition does the pressure per square inch depend?

A water column two and three tenths feet high exerts a pressure of one pound per square inch. For rough calculations a water column two feet high presses approximately one pound per square inch and a mercury column two inches high presses approximately one pound per square inch.

#### BOOKS FOR SPECIAL STUDY:

*General Science* — Barber.

*Practical Talks on Farm Engineering* — Clarkson.

*Home Water Works* — Lynde.

*Submarines* — Talbot.

## 6. MEASURING GAS PRESSURES

To determine the pressure of gas in the illuminating gas pipe.

MATERIALS. Manometer tube; rubber connections; glass jar; glass tube.

NOTE: If the manometer tube contains mercury from the previous experiment, ask the instructor to remove it. Fill the manometer half full of water, attach it to the gas outlet and open the gas cock. Measure the difference between the levels on the two sides of the U-tube.

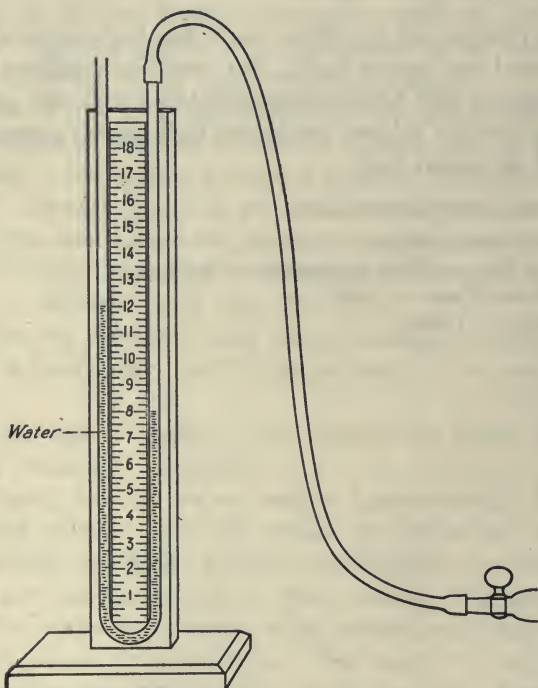

FIG. 6. — Measuring gas pressure with water in the manometer.

1. What is the pressure of the gas in inches of water column?
2. Calculate from No. 1 the pressure of the gas in pounds



per square inch. Refer to Experiment 5, Measuring Fluid Pressures.

3. The common electric vacuum cleaners (centrifugal fan type) produce "suction" sufficient to support a column of water from eight to twelve inches in height. What pressure in pounds per square inch is produced by ten inches of water column?

4. The pressure of the air in an automobile tire is eighty pounds per square inch. How high would this pressure support a mercury column? a water column?

5. If a water faucet pressure can support forty inches of mercury, what pressure is this in pounds per square inch?

6. A man's blood pressure in the arteries is sufficient to support a column of mercury five inches high. What pressure in pounds per square inch does this represent?

7. Attach a rubber tube to an eight-inch glass tube and connect the rubber end to the gas outlet. Insert the glass tube at least six inches under the surface of a jar of water. Turn on the gas and explain how this may be used to determine the gas pressure in pounds per square inch.

8. If the atmosphere can exert sufficient pressure to hold up a thirty-inch column of mercury, what pressure is this in pounds per square inch?

9. If a boy blows into a long glass U-tube with sufficient force to support a six-foot water column, what is his lung pressure in pounds per square inch?

#### BOOKS FOR SPECIAL STUDY:

*General Science* — Barber.

*General Science* — Hodgdon.

*Physics* — Mann and Twiss.

*Physics* — Black and Davis.

## 7. THE HYDRAULIC ELEVATOR

To construct a hydraulic elevator and study its operation.

**MATERIALS.** Brass piston rod used in pump experiment; No. 7 two-hole stopper (one hole at the center); No. 6 one-hole stopper; No. 10 one-hole stopper; four glass Ls; two four-inch rubber tubes; one twelve-inch rubber tube with faucet stopper.

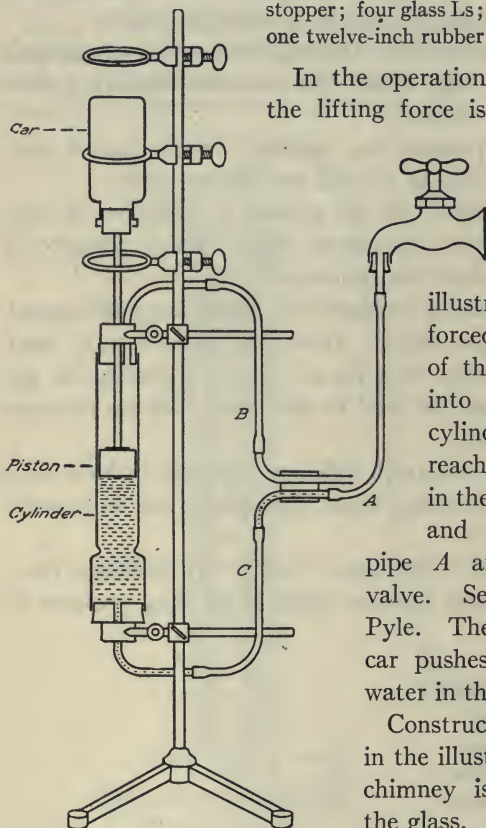

FIG. 7. — The hydraulic elevator.

In the operation of hydraulic elevators the lifting force is obtained by allowing water under high pressure to enter one end of a cylinder containing a movable piston.

In the type of elevator illustrated here the piston is forced upward by the pressure of the water as it is directed into the lower end of the cylinder. When the piston reaches the top, the operator in the car, by means of a lever and cables, closes the inlet pipe *A* and turns a three-way valve. See Millikan, Gale and Pyle. Then, as the weight of the car pushes the piston down, the water in the cylinder passes out.

Construct the apparatus as shown in the illustration. Note how the chimney is held. Do not clamp the glass. The piston rod and piston stopper should fit sufficiently tight to prevent leakage, but the piston should not move with too much difficulty. If the piston rod is too tight, place a few drops

of oil on it to reduce friction. To prevent a blowout at the wrong place, tie all rubber connections except the one at *A* with heavy thread. The one not tied will blow out in case of excessive pressure. Set the apparatus in the sink. If it does not work, try to correct the trouble. Ask the instructor for assistance if you do not succeed.

1. If the area of the piston were one hundred square inches and the pressure of the water fifty pounds per square inch, what force in pounds would be exerted against the piston?

2. Make two diagrams of a three-way valve — one showing the course of the water as the piston goes up and one as the piston goes down. See Millikan, Gale and Pyle.

3. The piston which operates a large hydraulic elevator has an area of 200 square inches. If the water enters the cylinder at one hundred pounds per square inch, how much force in pounds does this piston exert?

4. How much work in foot pounds does this piston accomplish when the force obtained in problem 3 is pushed through sixty feet in lifting a car?

5. When the piston is going upward, in what direction is the pressure on the bottom stopper of the cylinder? State Pascal's Principle. Refer to texts. This principle is employed in the operation of hydraulic presses. See textbooks. If the piston is made large and the water is pumped into the cylinder at high pressure, the piston may be made to exert thousands of tons pressure. Hydraulic presses are used for compressing cotton, for making cider, for bending steel railroad rails, and for shaping metal parts known as pressed steel.

6. Make a careful diagram of the apparatus.

#### BOOKS FOR SPECIAL STUDY:

*Physics* — Millikan, Gale and Pyle.

*Physics* — Black and Davis.

## 8. FLOATING BODIES

To show that a floating body displaces a volume of water equal to its own weight.

**MATERIALS.** Lamp chimney; No. 7 stopper; lead weight; aluminum pan 6 in. top diameter; platform balances; hydrometer jar, 12 in. high, outside diameter  $2\frac{1}{2}$  in.

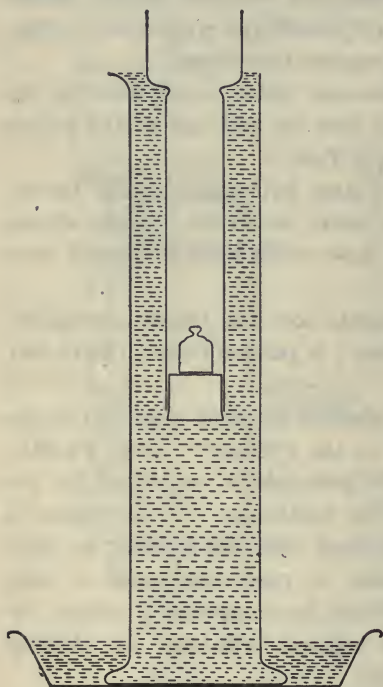

FIG. 8. — A floating body displaces its own weight of water.

Balance the scales carefully before weighing any object. Make up a float according to the diagram, using a lamp chimney, a solid stopper (or one-hole stopper closed with a solid glass rod) and a lead weight. Weigh separately the float and the pan to tenths of a gram.

Place the jar in the pan and carefully fill the jar with water to the point of overflowing. Gradually lower a weighted chimney till it is supported by the upthrust of the water. The water which is displaced by the float (chimney) will be caught in the pan. (NOTE: The reliability of the calculation and results will depend upon the accuracy of your work.) Remove the jar and reweigh the pan with the overflow water in it.

1. What is the weight of the float?
2. What is the weight of the water which it displaces when it floats?

3. State the Law of Floating Bodies (Archimedes' Principle). Explain its application to the experiment just completed. Explain any error which you may have found. See texts.

4. Who was Archimedes? See Millikan, Gale and Pyle, or other text.

5. When a boat or other object floats on water what two things are of equal weight?

6. With respect to the Law of Floating Bodies, when may a boat be expected to sink?

7. If a balloon goes up, what may be said of its own weight with respect to the air that it displaces? A balloon is buoyed up by the air according to the law of floating bodies. A balloon rises from the earth through the air in a manner similar to that of a cork which has been pushed to the bottom of a jar of water and then released.

8. If a balloon falls to the ground, what may be said of its weight with respect to the air that it displaces?

9. If a balloon just floats (stands still in the air), what may be said of its weight with respect to the air that it displaces?

10. With respect to the Law of Floating Bodies, to what height may a balloon be expected to rise?

11. Explain why a soap bubble filled with hydrogen goes up, while an ordinary air soap-bubble goes down.

#### BOOKS FOR SPECIAL STUDY:

*Submarines* — Talbot.

*All About Ships* — Darling.

*Physics* — Millikan and Gale.

*General Science* — Barber.

*Household Physics* — Butler.

## 9. THE HYDROMETER

To make a constant immersion hydrometer and test the specific gravity of a salt solution.

**MATERIALS.** Thin wall glass tube, length 3 in., outside diameter 7 mm., thickness of wall  $\frac{1}{2}$  mm.; test tube, length 6 in., diameter  $\frac{3}{4}$  in.; platform balances; No. 2 stopper; lead shot; salt solution.

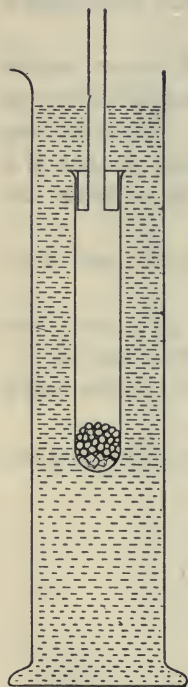

FIG. 9.—Hydrometer — constant immersion type.

Specific gravity is the ratio of the weight of a volume of a substance to the weight of an equal volume of water.

**A. Making a Hydrometer.** Insert a thin glass tube three inches in length into the stopper and, after placing a little crumpled paper in the bottom of a test tube, fasten the stopper firmly into it. Do not change the position of the stopper till the experiment is completed. Drop shot through the tube into the bottom of the test tube till the hydrometer sinks in fresh water beneath the stopper, to some convenient point on the thin glass tube. Mark this point with a loop of thread. See model made by the instructor.

1. Balance the scales carefully before weighing any object. Dry the hydrometer before weighing. Weigh the hydrometer to tenths of a gram.
2. Now float the hydrometer in the salt solution of unknown specific gravity. Add enough shot to sink it to the former mark. Reweigh.
3. How do these two weights give a basis for determining the specific gravity of the salt solution?
4. What is the specific gravity of the salt solution?

In the metric system a cubic centimeter of water weighs one gram. Therefore, the weight in grams of a cubic centimeter of

any substance is the same as its specific gravity. A cubic centimeter of mercury weighs 13.6 grams, therefore, its specific gravity is 13.6. *Density*, when expressed in grams per cubic centimeter, means the same as specific gravity. In general *density* refers to the weight of a unit volume of any substance, for example, grams per cubic centimeter or pounds per cubic foot.

**B. Hydrometers.** The device constructed in *A* is a hydrometer of constant immersion and variable weight. Ordinary specific gravity hydrometers are of variable immersion and constant weight. The point to which the hydrometer sinks in water is represented as Specific Gravity 1. In a lighter liquid like alcohol, sp. gr. 0.8, the hydrometer sinks deeper to a point marked 0.8. In a heavier liquid like glycerine the hydrometer sinks less deeply to a point marked 1.26. In a lead storage battery, such as is used in automobile self-starting and ignition systems, a specific gravity below 1.15 indicates that the battery is completely run down and needs recharging. A battery fully charged tests approximately sp. gr. 1.3.

5. How could the hydrometer of *A* be made to indicate specific gravity directly like the ordinary specific gravity hydrometer?

6. Make a careful diagram of a typical hydrometer (variable immersion) and explain it. See Hoadley, Black and Davis, Millikan, Gale and Pyle.

The Baumé hydrometer was one of the earliest hydrometers in use and its scale does not refer directly to the weight of an equal volume of water. The ordinary specific gravity hydrometers compare the weight of a substance with the weight of an equal volume of water. Similar instruments used for various commercial purposes are alcoholometers for liquors, salimeters for salts, lactometers for milk, etc.

#### BOOKS FOR SPECIAL STUDY:

*General Science* — Barber.

*Physics* — Black and Davis.

*The Gasoline Automobile* — Hobbes, Elliott and Consoliver.

## 10. THE SIPHON

To operate a siphon and explain its action.

**MATERIALS.** Two 24-in. glass tubes; two 12 oz. bottles; 10-in. rubber tube.

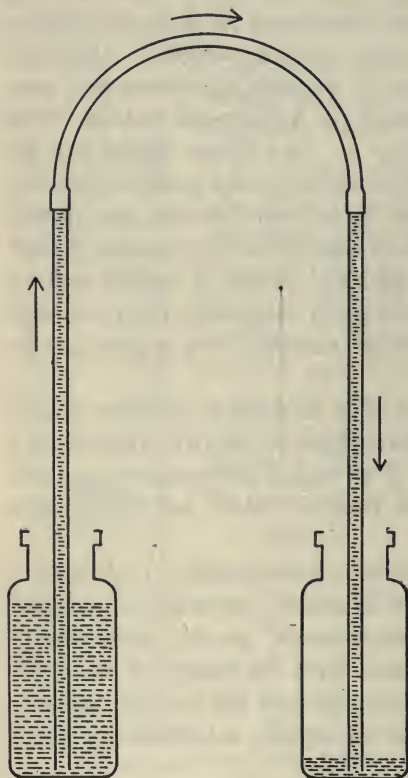

FIG. 10. — A siphon.

Fill the bottles half full of water. Connect the glass tubes by means of the rubber tube and fill with water. Close the tube by pressing at the rubber connection and insert one end in each bottle. Note that if one bottle is raised so that the water level is higher in one than in the other, water flows through the tube until the levels are the same.

1. When a siphon is in operation, which arm contains the heavier water column?

2. When the water level in the two bottles is the same, why does the water column not separate at the top and run back into the bottles? Refer to texts—Siphon.

3. How could you make a siphon work more rapidly?

4. Is it possible to siphon water from a lower level to a higher level? Explain.



5. If we should make a siphon reaching over a house forty feet high, would you expect water to remain at the top of the pipe? Explain. See Millikan, Gale and Pyle, or other texts.

6. When the siphon is working, if a hole were made in it at the top, what would be the result? Explain.

7. Mention at least two uses for the siphon. See Carhart and Chute, or other texts.

Suggestions. The pressure of the atmosphere (15 lb. per sq. in.) is exerted upward against both ends (water levels of the siphon). Thus, so far as the atmospheric pressure is concerned, the two pressures are opposite and they balance each other. But the weight of the water in the long arm decreases the upward pressure of the atmosphere on the long arm side, and the weight of water in the short arm decreases the upward pressure of the atmosphere less than on the long arm side. Therefore, the greater force on the short arm forces water up the short arm. The explanation may be stated in other words as follows:

On account of its weight, the water in the two arms of the siphon tends to separate at the top and produce a vacuum, but atmospheric pressure prevents this. The weight of the water on the long arm side produces a greater suction (tendency to form a vacuum at the top), than on the short arm side, therefore, water flows from the short arm side into the long arm side.

If a siphon more than 34 feet high should be filled with water, the water would separate at the top and form a vacuum because the atmospheric pressure (15 lb. per sq. in.) can support only a 34-foot column. The water in both arms would drop back to the 34-foot level. This siphon, of course, would not flow.

#### BOOKS FOR SPECIAL STUDY:

*General Science* — Barber.

*Household Physics* — Butler.

*Mechanics of the Household* — Keene.

## II. THE SIPHON FOUNTAIN

To construct a siphon fountain.

**MATERIALS.** 12-oz. bottle; No. 7 two-hole stopper; 5-in. nozzle tube; 3-in. glass tube; two 12-in. rubber tubes; two 12-oz. bottles; 2-ft. glass tube.

Support the bottle on a ring stand by means of rings. See instructor's model. Insert a glass nozzle tube through a two-hole stopper into the mouth of the inverted bottle. Connect the end of this tube to a jar of water on the table. Through the other hole of the stopper lead a tube to a jar on the floor. Fill the tube leading to the floor with water and insert into the jar on the floor. See model made by the instructor.

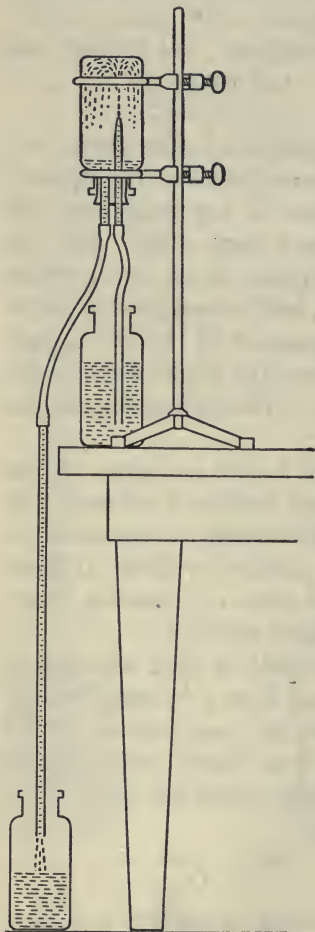

FIG. 11. — The siphon fountain.

1. Explain the condition of the air in the bottle when the fountain is in operation.
2. How could the fountain be made more forceful?
3. Assuming the atmospheric pressure to be 15 lbs. per sq. in., how much does a three-foot column leading to the floor decrease the pressure of the air in the bottle? What is the pressure of the air in the bottle when a three-foot tube is attached?

4. What would be the approximate pressure of air in the bottle if the water column leading from it were 20 feet long?
5. Kerosene is four-fifths as heavy as water. If water can be siphoned 34 feet, how high can this oil be siphoned?
6. How high can mercury be siphoned? Mercury is 13.6 times as heavy as water.
7. State the conditions that must be fulfilled in the operation of a siphon.

BOOKS FOR SPECIAL STUDY:

*General Science* — Barber.

*Household Physics* — Butler.

*Physics* — Carhart and Chute.

## 12. PRESSURE TANK WATER SUPPLY BOYLE'S LAW

**To illustrate the operation of a pressure-tank water supply for a dwelling house.**

**MATERIALS.** Large glass tube, 2 feet long, outside diameter three-quarters inch, inside diameter nine-sixteenths inch; glass tube 2 feet long; heavy rubber tubing, two twelve-inch pieces; brass T-tube; No. 0 one-hole rubber stopper; small bilge pump; hydrometer jar; two strong screw clamps; heavy thread; half meter stick.

In country districts isolated from the regular city water mains, buildings are sometimes supplied with water under pressure by pumping the water from a well with a gasoline engine, windmill, or some other source of power, into a large heavy metal tank, located in the basement. The principle involves having the upper part of the tank filled with air. Water is forced into the lower part of the tank by means of a pump and the air above is compressed. The compressed air then acts with continuous pressure to force the water into the pipe leading to the faucets in the building.

The compressed air in the tank acts according to Boyle's law. *The volume of an enclosed gas varies inversely as the pressure on it.*

This means that by doubling the pressure on a volume of air, or other gas, its volume is reduced one-half. See text.

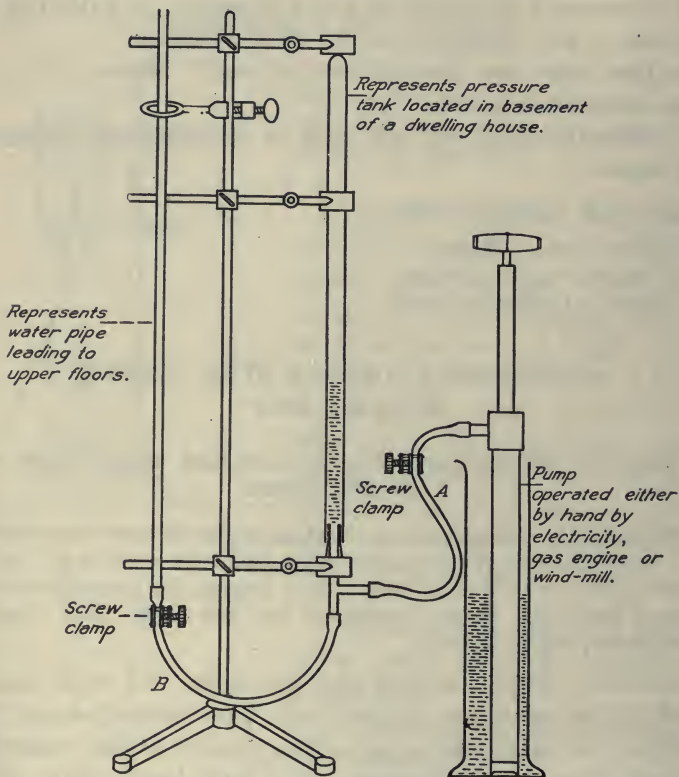

FIG. 12. — Compressing a gas (air), Boyle's Law.

NOTE. To avoid spilling water on the laboratory tables and floor, place the apparatus in the laboratory sink.

(Tie all rubber tube connections with thread to prevent blowing out.) Place about six inches of water in the large tube. Insert stopper tight and pressure inside at the beginning should be atmospheric (15 lbs. per sq. in.). Close clamp *B* and slowly pump in additional

water until the water level is forced upward about one-fourth of the distance to the top. The enclosed air is then reduced to about three-fourths of its original volume. Then close the clamp at *A* to hold the pressure. At this point measure carefully in millimeters the length of the compressed air column. Now release clamp *B* and allow the compressed air to force the water out through the thin tube. When the enclosed air is again at normal atmospheric pressure, measure in millimeters the length of the air column. The length of the air column of a uniform tube may be taken to represent its volume.

1. Under what pressure is normal atmospheric air? See text.
2. What was the length of the enclosed gas column (air) under atmospheric pressure (the second measurement)?
3. What was the length of the enclosed gas column under added water pressure (first measurement)?
4. According to Boyle's Law, calculate the total pressure on the inclosed air when the volume was reduced. The pressure will be as many times the atmospheric pressure (15 lbs.) as the volume (when compressed) is less than the atmospheric volume (normal volume).
5. What does the total pressure of question 4, minus 15 lbs., represent?
6. If the volume of atmospheric air is compressed to one-third of its normal volume, what total pressure per square inch (including atmospheric) would then be exerted upon it?
7. If the total pressure in a pressure tank in a house is thirty pounds per square inch (15 lbs. above atmospheric) how high would this pressure raise water in the pipes of the building? See illustration, Barber's *General Science* — Pneumatic Tank.

#### BOOKS FOR SPECIAL STUDY:

- Mechanics of the Household* — Keene.  
*General Science* — Barber.  
*Home Water Works* — Lynde.

## 13. FAUCET WATER PRESSURE — BOYLE'S LAW

To measure faucet pressure with the closed manometer.

**MATERIALS.** Same apparatus as in the Pressure Tank Water System with glass L-tube in place of T-tube; pressure-tubing and faucet stopper.

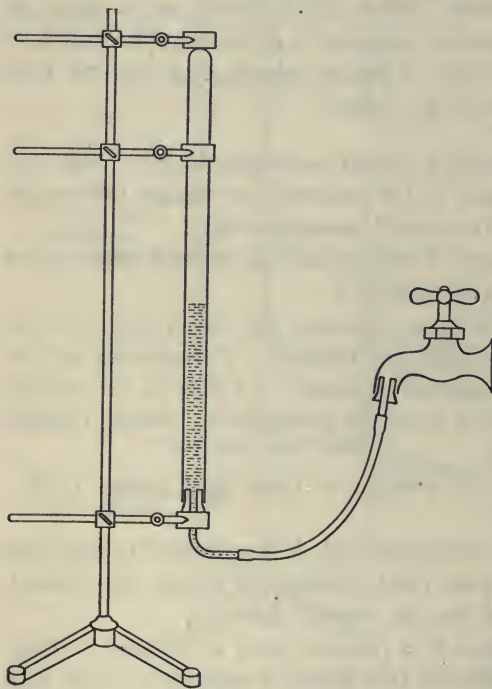

FIG. 13. — Faucet water pressure measured by compressing air in a tube — Boyle's Law.

Fill the glass tube half full of water and attach it to the ring stand as shown in the illustration. By means of tubing and a rubber stopper, connect it firmly to the faucet. Note that the air enclosed in the tube is compressed when the water from the faucet rushes in. (*Caution. If the faucet pressure is very high, it will be necessary to use special pressure tubing and special precautions will be required to prevent a blow-out.*) Measure in millimeters the

length of the enclosed air column with faucet turned on and the air compressed. Remove the faucet stopper, allowing the compressed air to expand again to normal volume. Measure again at normal volume, holding the stopper (water level in the stopper)

on the level of the water in the compression-tube. If the pressure volume is measured first any air bubbles which enter with the pressure water will not cause an error in the result.

1. If this final volume represents atmospheric pressure (15 lbs.), what pressure in pounds per square inch is represented by the volume when the faucet pressure is on? Apply Boyle's Law. This pressure includes both atmospheric pressure and the additional pressure of the water. Subtract fifteen pounds from this pressure to get the pressure of the water alone.

2. Normal air is under a pressure of fifteen pounds per square inch. If a faucet pressure compresses the air to one-fifth of its normal volume, what total pressure produces this effect?

3. In question 2 how much of the pressure is caused by the water in the pipes and how much by atmospheric pressure? The atmospheric pressure is on the water at the reservoir or where it enters the pipes.

4. In question 2 how many feet of water column must be added to the fifteen pounds atmospheric pressure to produce the total pressure? Two and three-tenths feet of water column produce one pound pressure per square inch.

To determine the pressure due to water alone, subtract fifteen pounds from the total pressure of question 2. This is the pressure of the water as indicated by an ordinary pressure gauge.

5. If the air in an automobile tire is compressed to one-fifth of its normal volume, what pressure per square inch does it exert against the inside of the tire?

6. What pressure is exerted against the outside of an automobile tire?

7. If a pumped up automobile tire were placed in a vacuum, would it be more or less likely to burst? Why?

BOOKS FOR SPECIAL STUDY:

*Practical Physics* — Black and Davis.

*Household Physics* — Butler.

*Mechanics of the Household* — Keene.

## 14. STEAM HEATING SYSTEM

To construct a one-pipe steam heating system.

**MATERIALS.** Bunsen burner; 500 c.c. flask with neck for No. 6 stopper; two 12-oz. bottles; two brass T-tubes; one glass L-tube; glass tube 4 inches long; glass tube 12 inches long; 2 glass tubes 8 inches long; No. 6 two-hole rubber stopper; two No. 7 2-hole rubber stoppers; two rubber tubes, 5 inches; wire gauze; pinch clamp; three short rubber tubes.

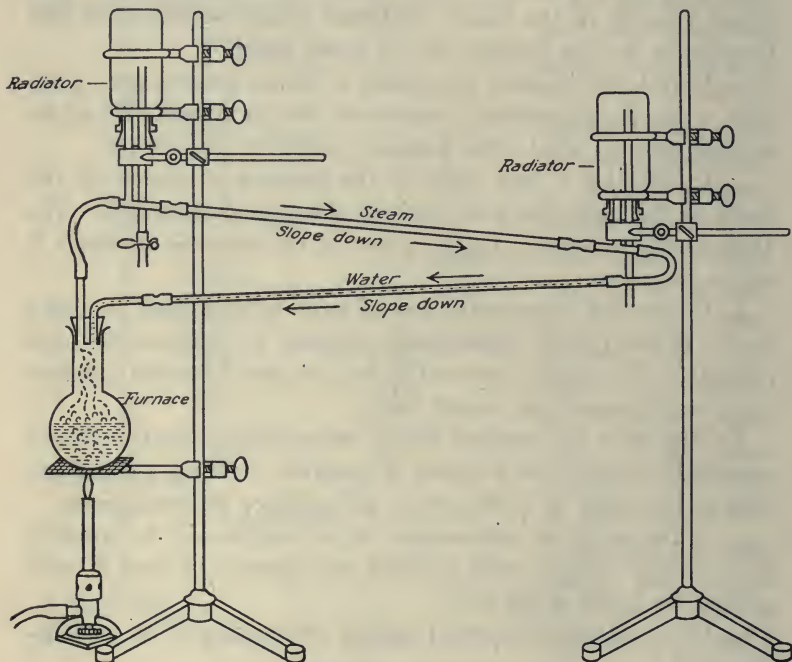

FIG. 14. — One-pipe steam heating system.

**A. Constructing a Steam Heating System.** Set up the apparatus as shown in illustration. Observe, carefully, the proper sloping of pipes for drainage. Boil water in the flask, having outlets of both bottles open. When the bottle nearer the flask becomes heated, close the pinch clamp.



1. How could the pressure in these bottles and in the entire system be increased? In steam heating systems, a pressure of from 0 to 5 lbs. per square inch is common. However, in small dwellings the pressure is frequently allowed to drop to  $\frac{1}{2}$  lb. or less, except on very cold days. In these systems, all air-escape valves of radiators, corresponding to pinch clamps, should be closed during regular operation. If the pressure rises too high, an automatic safety valve at the boiler allows the steam to blow off into the basement.

2. After the water reaches the boiling point ( $212^{\circ}$  F.), what becomes of all the heat that goes from the flame into the flask, since the temperature of the water is not raised above  $212^{\circ}$  F.?

3. How does increasing the pressure affect the boiling point? See Millikan, Gale and Pyle, Black and Davis, Ontario Physics. In ordinary steam heating systems, a fairly constant temperature is maintained in the radiators, the room temperature being regulated best by having two or more radiators in each room. This is desirable, because one-pipe steam radiators must be operated with the valve completely open or they must be turned off completely.

4. How is it possible to provide for three different rates of heating a room by means of two radiators, a small one and a large one? This provides for temperature conditions at different seasons. In hot-water systems the room temperature may be regulated by varying the temperature of the water or by opening the radiator valve more or less widely.

5. Explain what is happening in the steam radiator. One gram of steam in condensing to water gives out 540 calories of heat. A radiator is considered efficient if under the ordinary conditions of steam pressure, volume and temperature of surrounding air, it will condense a large amount of steam in a given time. Consequently the amount of heat given off depends upon the difference of temperature between the steam in the radiator and the surrounding air, the velocity of air over the radiator, and the color of the radiator. If a radiator is black, it gives off a little

more heat than one painted some lighter color. Open pipe-coils allow air to circulate more freely and, therefore, give off more heat than radiators.

6. What is the advantage of the large feed circuit (basement circuit from the boiler back again to the boiler) in a one-pipe system? (A 2 or 2½ inch basement circuit pipe is common in dwellings.) Two-pipe systems may have smaller pipes.

7. Why is it necessary to have a continuous down slope from the radiators to the boiler? What would happen if a pocket (imperfect drainage) occurred in the pipe leading steam from the boiler to the radiators?

8. What is the purpose of a small valve (air vent) on the side of a steam radiator? See *Mechanics of the Household*, Keene — Vents.

**B. Vacuum Steam Systems.** Dwelling house vacuum systems have special valves which prevent air from entering the radiators when the steam pressure drops. A vacuum steam system, if it works properly, is economical in moderate weather because it requires less heat to force vapor into the radiators and thus saves coal. In dwelling houses these special systems are hard to keep air-tight and often work no better than ordinary steam systems.

Special vacuum systems are used in large buildings, operated by means of a special suction pump, to which pipes lead from the radiators. This pump keeps the radiators free of air and prevents bumping when the valves are partially closed. See *General Science*, Barber.

**C. Noises.** Explain noises (*a*) when steam enters a cold radiator (expansion of the metal parts), (*b*) when the inlet valve is only partially open (bumping of water and vacuum hammer).

#### BOOKS FOR SPECIAL STUDY:

*Household Physics* — Butler.

*Physics of the Household* — Lynde.

*Mechanics of the Household* — Keene.

*General Science* — Barber.

## 15. HEAT OF CONDENSATION (OR VAPORIZATION) LATENT HEAT

To find how many heat units (calories) are given out by the condensation of a gram of steam

**MATERIALS.** Bunsen burner; two 500 c.c. flasks; L-tube with long arm 8 inches long; No. 6 stopper; balances; Centigrade thermometer; wire gauze; cloth or paper insulator.

### A. Determining the Heat of Vaporization.

Construct a steam generator by means of a flask, a stopper, and a delivery tube as shown in instructor's model. Fill the flask half full of water and heat it till it boils with Bunsen burner flame so that a strong jet of steam flows from the delivery tube.

**NOTE.** The success of this experiment depends chiefly upon accurate weighing and reading of the temperatures. Balance scales before weighing.

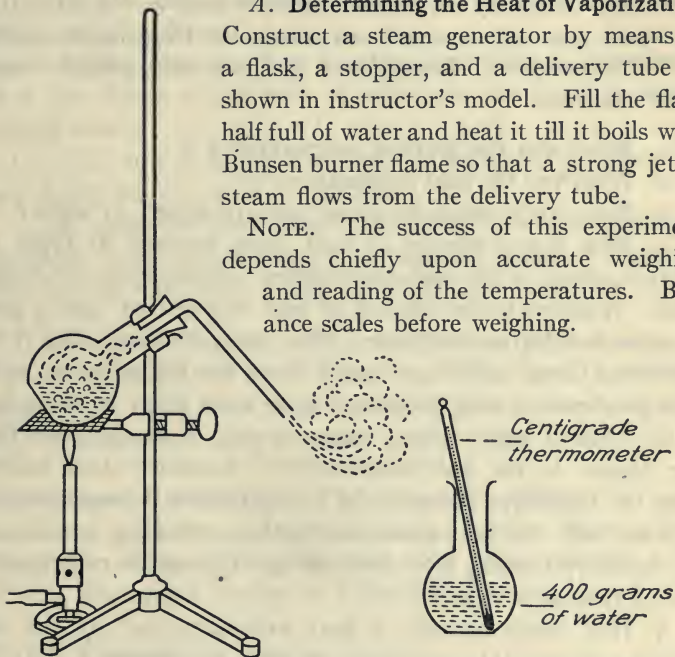

FIG. 15. — Steam generator and apparatus for determining the amount of heat given out when a gram of steam condenses to water.

Weigh the second flask empty, and then add very carefully 400 grams of cold water. Place a centigrade thermometer in this flask and note the starting temperature of the water. Insulate the flask

with a wrapping of paper. Holding the weighed flask with the hand, place it quickly into position so that the steam is delivered into the center of the volume of water. The cold water will condense the incoming steam and the temperature of the original water will rapidly rise. (*Caution. Do not at any time during this operation remove the flame from the steam generator flask, as this would cause a partial vacuum.*) Keep the thermometer in the flask during the operation, stir slowly, and when the temperature has been raised approximately 20 degrees, quickly remove the flask from the steam generator, and note accurately the temperature reading on the thermometer. Reweigh and find how many grams of steam were condensed.

1. What was the starting temperature?
2. What was the final temperature?
3. How much steam in grams was condensed to water?
4. How many calories of heat were required to bring the original water to its final temperature (grams water  $\times$  degrees rise)? A calorie is the amount of heat required to raise a gram of water one degree centigrade. The grams of steam, after it was condensed, must also have cooled from the boiling point to the final temperature and, therefore, must have given up some heat to the original water (grams steam  $\times$  drop in temperature from 100 degrees to the final temperature). Subtract these calories from the total heat given to the original water, because we wish to know only the heat given out by the condensing process, not by the further cooling after condensing. Repeat the experiment a second time as a check.

5. How many calories of heat were given out by the condensing process only (according to your calculation)?

6. How many calories of heat were given out by one gram of condensing steam (on the basis of your calculation)?

7. How do your results compare with the accurate determination of the Heat of Vaporization of Water? Refer to text. Inquire of instructor whether your results are satisfactory.

8. If some heat were lost by condensation of steam in the delivery tube, would this make your result lower or higher than it should be?

9. If some heat were lost through the flask to your hand, or to the surrounding air, would this make your result lower or higher than it should be?

10. If some heat were lost in heating the glass of the condensing flask, how would this affect the result?

11. How is this experiment related to the heat which comes from a steam radiator?

12. Explain the fact that evaporating moisture, perspiration, or a few drops of alcohol, or ether, on the hand produce a cooling effect.

13. Is it possible to raise the temperature of water boiling in an open kettle above  $212^{\circ}$  F.? Explain.

14. It takes less than one-fifth as long to heat a quantity of ice water to the boiling point as it takes to change it completely from boiling water into steam. Explain this statement.

A common method of making artificial ice depends upon the heat of vaporization of liquid ammonia. When liquid ammonia is vaporized it takes in so much heat that, if water stands near, the heat is taken away from the water and it freezes.

**B. Law of Vaporization.** The general law relating to vaporization and condensation may be stated as follows: When a liquid changes to a gas, it takes in heat or it must get heat. Conversely, when a gas changes to a liquid it gives out heat.

#### BOOKS FOR SPECIAL STUDY:

*Heat* — Ogden.

*Physics* — Mann and Twiss.

*Practical Physics* — Black and Davis.

*Mechanics of the Household* — Keene.

*General Science* — Barber.

## 16. HOT-WATER HEATING SYSTEM

To construct a model of a hot-water heating system and study its operation.

**MATERIALS.** Two 12-oz. bottles; 500 c.c. flask; three brass T-tubes; two 12-in. glass tubes; three 6-in. glass tubes; funnel; rubber connections and tubing; two No. 7 3-hole rubber stoppers; No. 5 2-hole rubber stopper; wire gauze; Bunsen burner; pinch clamps.

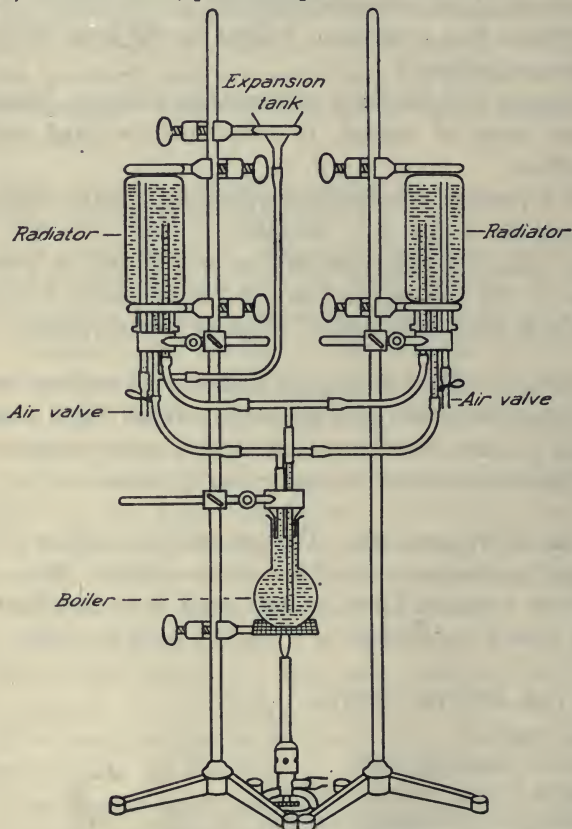

FIG. 16. — Hot-water heating system.

**A. Constructing a Hot-Water Heating System.** Set up apparatus as shown in the illustration. The expansion tank should stand at a higher level than the radiators. Fill the apparatus with water and heat the flask. Make all connections tight. Tie with heavy thread if necessary. Force stoppers in as tight as possible to avoid flooding the table. Note carefully the position of clamps and rings.

**The Operation.** Put a flame under the flask. As the water in the boiler becomes heated, a circulation is set up. The water in a hot-water heating system should not be allowed to boil.

1. What causes this circulation in a hot-water heating system?
2. What is the reason for making one pipe reach to the bottom of the flask?
3. Why does the circulation move more slowly when the radiators get hot than when they are cold?
4. It takes longer to heat up a hot-water heating system than a steam system. Explain.
5. What is meant by the specific heat of a substance? Refer to text for the meaning of specific heat. How is the specific heat of water involved in question four? Why is a hot-water heating system less variable in temperature than a steam heating system?
6. What is the purpose of the expansion tank? See diagram — *General Science*, Hodgdon; *Household Physics*, Butler.
7. Air collects in hot-water radiators. Where does it come from?
8. Can you suggest a means by which you might cause the circulation to flow in the opposite direction?
9. Radiators that are directly over the furnace are usually warmer than those that are at the same level but in some more remote position. Explain.
10. Draw a diagram of the apparatus and indicate the direction of flow by means of arrows.

**B. Heating Systems.** There are three common types of house heating systems which include furnaces: *a.* Steam. *b.* Hot water. *c.* Hot air.

Advantages of hot-water compared with steam in heating systems. *a.* Little possibility of explosion. *b.* The amount of heat in the radiator may be controlled perfectly at the supply valve. *c.* Little or no noise. *d.* Hot-water radiators give off heat below the boiling temperature and, therefore, require less coal in moderate weather.

Disadvantages of hot-water as compared with steam. *a.* Danger of freezing. *b.* Costs about one-third more to install. *c.* Radiators are larger and require more room space. *d.* Hot-water requires longer to heat up.

#### BOOKS FOR SPECIAL STUDY:

*Household Physics* — Butler.

*Physics of the Household* — Lynde.

*General Science* — Barber.

*Mechanics of the Household* — Keene.

### 17. HEAT OF FUSION (LATENT HEAT)

**To determine the heat required to melt one gram of ice.**

**MATERIALS.** Dry cracked ice or snow; two 250 c.c. beakers; balance; centigrade thermometer; wire gauze; Bunsen burner.

**A. Determining the Heat of Fusion of Ice.** Heat a beaker full of water to the boiling point ( $100^{\circ}$  Centigrade). Balance scales before weighing. Weigh a second beaker empty. Fill quickly with dry snow or pieces of ice and reweigh, finding the weight of the ice. Slowly pour boiling water on the ice until it is melted, stirring constantly. Avoid a great excess of hot water. When the ice is melted record the temperature immediately and then reweigh.

1. What was the final temperature?
2. How many grams of boiling water were poured in?



3. How many calories of heat came from the boiling water (grams of boiling water  $\times$  degree fall from 100 degrees to the final temperature)?

4. After the ice was melted, how many calories were needed to raise the ice water at  $0^{\circ}$  C. to the final temperature (grams of ice water  $\times$  degrees rise from  $0^{\circ}$  C. to the final temperature)?

5. How many calories were used in the melting process only (difference between answers 3 and 4)?

6. How many grams of ice did this heat melt? How many calories are required to melt one gram of ice (heat of fusion of ice)? Inquire of instructor whether your results are satisfactory.

7. What are some sources of error in this operation? How does your result compare with the accurate determination of the heat of fusion of ice? Refer to text.

8. To what temperature would a gram of

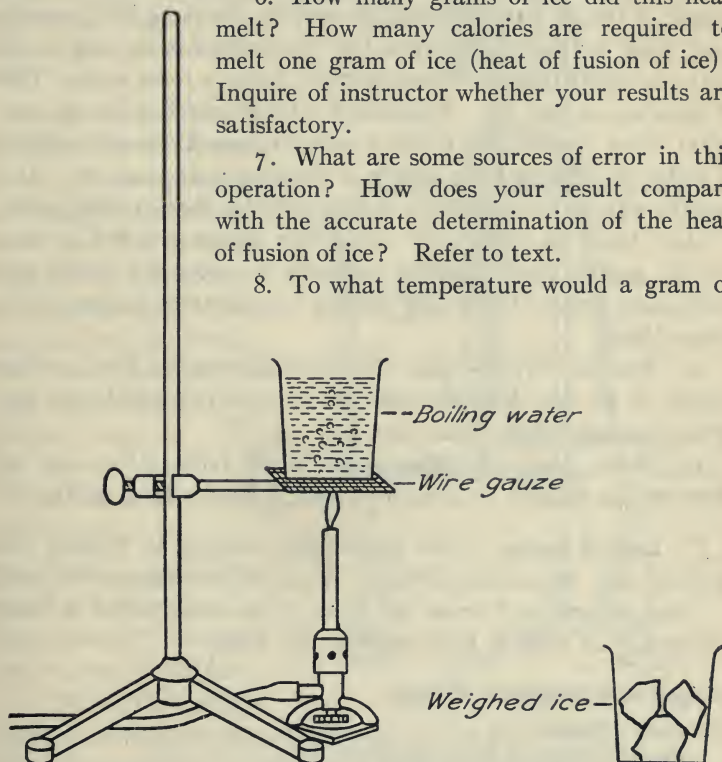

FIG. 17. — Apparatus for determining the amount of heat required to melt a gram of ice.

water at  $0^{\circ}$  C. be raised by the heat required merely to melt a gram of ice?

9. How does the amount of heat required to raise a kettle full of ice at  $0^{\circ}$  C. to the boiling point compare with the heat required to raise an equal weight of water from  $0^{\circ}$  C. to the boiling point?

**B. Conclusions.** This experiment shows that when ice melts it must take in a definite quantity of heat. Strange as it may seem, it is also true that when ice is freezing it is losing heat. For example, a tub of water freezing in a cellar prevents the temperature from falling much below the freezing point so long as the water is not all frozen. Freezing water keeps a room warmer than it otherwise would be. Apples and potatoes which freeze at somewhat below the freezing point of water are sometimes protected in a cellar by having large vessels of freezing water near by. It is usually warmer in the vicinity of a freezing lake than at other points.

Heat taken in when snow melts thus prevents a bed of snow on the ground from changing suddenly to water and serves as a protection against floods and sudden temperature changes in the atmosphere.

10. Explain why the heat that gradually passes into a refrigerator or ice box does not raise the temperature of the ice box. What becomes of any heat that gets in?

11. Before placing a piece of ice in the refrigerator, why not wrap it in a blanket or in heavy paper to keep it from melting?

**C. Law of Fusion.** The general law relating to freezing and melting may be stated as follows: When a solid changes to a liquid it takes in heat or it must get heat. Conversely when a liquid changes to a solid it loses or gives out heat.

#### BOOKS FOR SPECIAL STUDY:

*Heat* — Ogden.

*Practical Physics* — Black and Davis.

*Physics* — Millikan, Gale and Pyle.

*Household Physics* — Butler.

## 18. KITCHEN HOT-WATER TANK

To construct a model of a kitchen hot-water heater and explain its action.

**MATERIALS.** No. 50 Macbeth chimney; two 12-oz. bottles; two glass L-tubes; one L-tube with one 8-in. arm; brass T-tube; two 12-in. glass tubes; two 12-in. rubber tubes; two 10-in. glass tubes; one 6-in. glass tube; No. 7 two-hole rubber stopper; No. 10 one-hole rubber stopper; wire gauze; pinch clamp; Bunsen burner.

**A. Constructing a Kitchen Tank Model.**

Construct the apparatus following instructor's model and fill with water. Heat slowly at lower end of side tube, with wire gauze above the burner. The burner placed at this point represents a kitchen range or gas heater connected with a hot-water tank.

1. What causes the water in the tank to become heated? Does the water move? Explain.

2. When first applying heat, touch the pipe at different points and indicate the path of the heated water. Diagram the apparatus, showing the direction of flow by means of arrows,

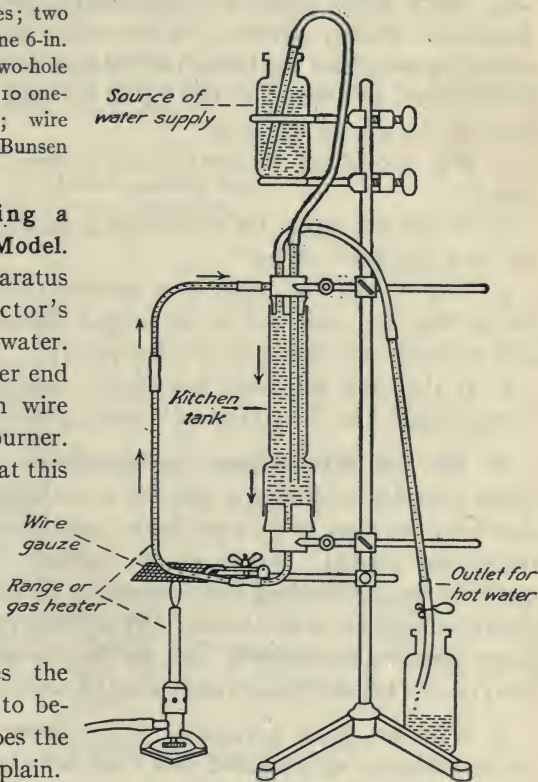

FIG. 18. — Range-tank water-heater.

3. Does the hot water in the tank mix readily with the cold water? Explain.

4. Why is the hot water taken in at, or near, the top of the tank?

In a gas-heated water tank, the water passes from the bottom of the tank through the heating coil, and then to the top of the tank, from which point it leads directly to the faucets. See *Household Physics*, Butler. When water is heated by a coal range, it passes from the bottom of the tank to the "water-back" in the range, and thence to the top of the tank, or to some other point at the side of the tank.

5. Why should the cold-water inlet be near the bottom of the tank?

6. Would you expect the circulation to continue as rapidly after the tank gets hot? Why?

7. Why should the pipes of a kitchen tank system be filled before they are made hot in the range? What might happen if cold water should rush into very hot pipes?

8. If the tank gets very hot, steam sometimes forms in the "water-back" or "water-front" causing loud noises. Explain.

**B. The Gas Water-Heater, Instantaneous.** The kitchen tank above provides for storing a quantity of hot water which is heated slowly by the stove or by a gas heater, and flows to the tank by a convection current. Where gas is available, hot water in any quantity may be obtained instantaneously by direct heating of the coils of a large gas water-heater. By a water pressure mechanism these devices automatically turn on the gas when the hot-water faucet in the house is opened and turn it off when the faucet is closed.

9. What are some advantages of an automatic instantaneous gas water-heater as compared with a kitchen range tank?

#### BOOKS FOR SPECIAL STUDY:

*Practical Physics* — Black and Davis.

*Household Physics* — Butler.

*Mechanics of the Household* — Keene.

## 19. THE LIQUID CELL AND THE DRY CELL

To make a Leclanché cell and study its action.

**MATERIALS.** Base block  $5 \times 5 \times 2$  in.; round battery-jar  $5\frac{1}{2}$  in. high  $\times 2\frac{3}{4}$  in. in diameter; ammonium chloride (sal ammoniac); zinc battery rod; carbon rod from an old dry battery cell; Bunsen burner; electric bell; No. 24 insulated wire; jar of 10 per cent nitric acid, to be used only by the instructor; cardboard, for separating battery rods at top; short glass tube, for separating battery rods at bottom; glass stirring rod.

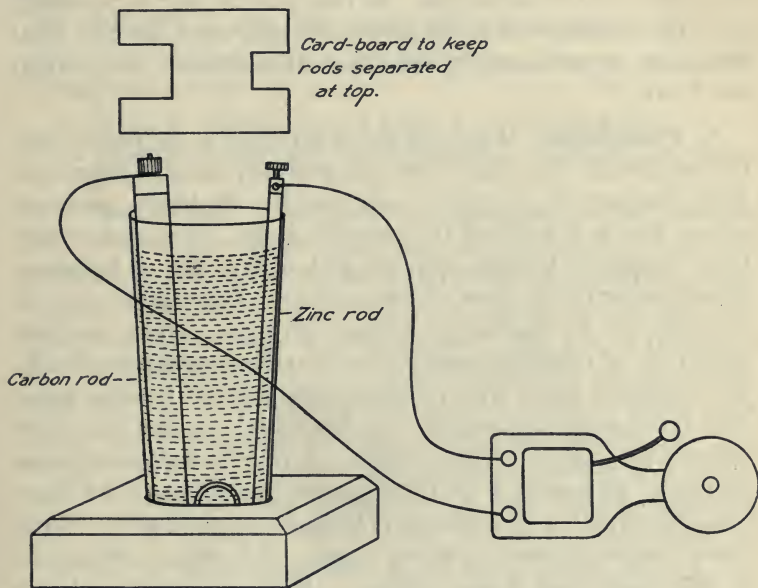

FIG. 19. — A liquid cell — Leclanché type.

**A. Making a Liquid Cell.** Make up an ammonium chloride solution by filling the battery jar one-fifth full of ammonium chloride salt and adding water till the top of the liquid stands one inch from the top of the jar. Dissolve by stirring with a

glass rod. Stand the zinc rod in the solution at one side of the jar, and the carbon rod at the other. Use a short piece of glass tubing at the bottom of the jar and cardboard at the top to keep the electrodes separated. See instructor's model.

1. Connect wires to the electrodes and ring an electric bell.
2. Make a drawing of the cell indicating the materials used, and showing the direction in which the current flows. The current is considered as flowing from the positive to the negative electrode outside the solution. The negative electrode is the one acted upon more by the electrolyte. In this case the zinc is negative.
3. In the operation of the Leclanché cell, what salt and what two gases are produced by the chemical reaction? See Carhart and Chute.

**B. Polarization.** When this cell is attached to the electric bell, it rings the bell for a short time and gradually becomes exhausted. This phenomenon is due to polarization. Hydrogen molecules are set free as a result of the chemical action. The carbon electrode gradually becomes covered with a thin film of hydrogen, which prevents the flow of the current. Polarization may be counteracted by placing in contact with the carbon electrode some form of oxidizing agent, as, for example, manganese dioxide. The hydrogen reacts with the manganese dioxide, forming water. This cell may be temporarily depolarized by heating the carbon rod in a gas flame for three minutes. It may be depolarized more effectively by heating it for three minutes and holding it for about a minute, while hot, in a solution of ten per cent nitric acid. (NOTE: *Nitric acid is a strong oxidizing agent. It is also a strong acid. It will discolor and destroy clothing.*) Hold the carbon rod in a gas flame for about three minutes. The instructor will then depolarize it for you in nitric acid.

4. What depolarizer or oxidizing agent is used in the construction of dry cells? See Carhart and Chute.
5. What is the voltage of an ammonium chloride cell? The

dry cell is a form of the ammonium chloride cell. Large cells have the same voltage as small ones. See Millikan, Gale and Pyle — Leclanché Cell.

6. Connect your cell in series with the cell made by some other student. How many volts should two cells in series have? Four cells in series? Refer to text.

7. Operate an electric bell by means of two liquid cells in series. What evidence have you that the voltage of two cells is able to force more current through the resistance of the bell than one?

8. Describe briefly the construction of a simple liquid cell which uses sulphuric acid as the electrolyte. Diagram it. Refer to some physics text.

9. What is meant by local action? See textbooks.

10. Diagram a dry cell. See Hoadley or Carhart and Chute.

C. **The Dry Cell.** The dry cell is a modification of the Leclanché cell. The negative electrode is a zinc can containing a carbon rod at the center. Between the zinc and the carbon is packed a damp mixture of ammonium chloride, sand, manganese dioxide, etc. The manganese dioxide is a depolarizer. The top of the can is then sealed with pitch to prevent the so-called dry cell from really becoming dry. If the pitch is cracked, or if holes are made in the zinc so that the moisture dries out, the cell becomes useless. The voltage of a dry cell remains fairly constant whether it is new or nearly discharged. The amperage will vary widely, depending upon age and usage. When a dry cell is short-circuited, the stored-up energy produces heat in the wires and in the cell. At present the dry cell has largely replaced the older forms of liquid cells.

#### BOOKS FOR SPECIAL STUDY:

*Physics* — Mann and Twiss.

*The Boy Electrician* — Morgan.

*Physics* — Millikan, Gale and Pyle.

## 20. MEASURING ELECTRIC CURRENT

To wire dry cells in series, and measure volts pressure and amperes flow.

**MATERIALS.** Two dry cells; No. 24 copper wire (insulated); battery-voltmeter; thirty-five ampere battery ammeter; push button.

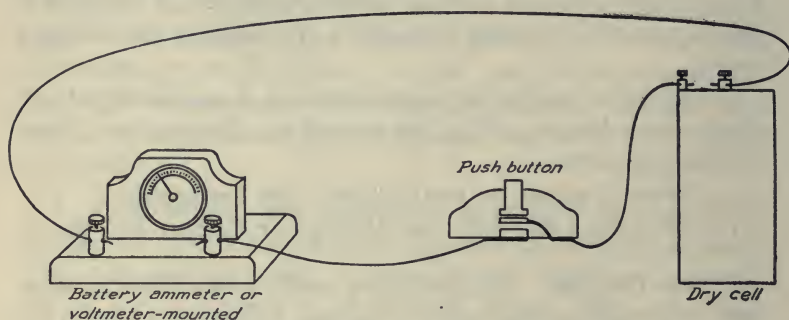

FIG. 20. — Wiring for measuring voltage or for testing amperage of a dry cell. See caution under *B* below regarding the use of expensive ammeters.

**A. Making Measurements.** Attach two wires firmly to the binding posts of one of the cells, taking care that the two wires do not touch each other and cause a short circuit. (A short circuit would heat the wires and rapidly waste away the energy of the cell.) Attach one wire to one of the voltmeter binding posts. Connect the other wire to one side of the push button. From the other side of the push button connect a wire to the second post of the voltmeter. Now push the button and read the voltage of the dry cell. In the same way measure the voltage of the second cell. (*Caution. In measuring amperes, the thirty-five ampere ammeter must be connected in series with a push button in order to avoid wasting the current.*) Connect one wire from the cell to one post of the meter. Hold the other wire firmly against the other post and push the button *for a moment*. Note the total



amperage output of each cell. Connect the two cells in series according to instructor's directions, and measure the voltage, then the output in amperes with the thirty-five ampere ammeter and push button. When you have finished working with dry cells take the wires off immediately to avoid accidentally short-circuiting them. Screw the top off the push button and examine it.

1. Make a table with two columns, one for volts and one for amperes. Record voltage and amperage output of cell No. 1, cell No. 2, the two cells in series, and three cells in series. (NOTE. These meters give only approximate readings.)

2. What is the correct voltage of a Leclanché cell? Same as dry cell. See Millikan, Gale and Pyle, or *Ontario Physics*.

**B. Meters.** (*Caution. Sensitive voltmeters and ammeters are easily ruined by attaching them to currents of too high voltage or too high amperage.*) Expensive meters have very delicately balanced indicators. Ammeters should always be connected in series with some instrument as a lamp or motor, except in special cases like measuring the output of the dry cell with a meter of high amperage scale.

3. What might happen to an ammeter which registers only five amperes (five ampere scale) if it were attached to a new dry cell, or to the 110-volt line without a lamp or some other instrument in series for resistance? A lamp or motor offers resistance and permits only a small amount of current (amperes) to flow.

4. How many dry cells are needed to supply twelve volts?

5. Diagram the proper number of cells in series to operate one six-volt lamp by means of a push button in the circuit.

6. Operate a three-volt lamp by means of dry cells. Diagram the proper number of cells to operate two three-volt lamps in parallel by means of a single push button.

**C. Cells in Parallel.** For special purposes dry cells are sometimes connected in parallel (positive to positive and negative to

negative). This produces the effect of a single cell of very large electrodes. The voltage is the same as that of one cell, but the amperage is increased according to the number of cells used.

7. Diagram a circuit containing three cells in parallel, operating three lamps in parallel. See Mann and Twiss.

#### BOOKS FOR SPECIAL STUDY:

*Physics* — Mann and Twiss.

*Physics* — Black and Davis.

*Physics* — Millikan, Gale and Pyle.

## 21. ELECTRIC LIGHT AND POWER

**To construct and operate a miniature electric lighting and power system, and measure the current.**

**MATERIALS.** Two ring stands; two clamps; two crossbars of wood or glass each 5 in. long; two dry cells; No. 24 copper wire (insulated); three 3-volt lamps; small 3-volt motor; electric bell; battery voltmeter; thirty-five ampere battery ammeter; push button.

**A. Setting up a Miniature Wiring System.** Using two ring stands as supports, attach two wooden crossbars by means of clamps. See instructor's model of the apparatus. To these crossbars lead two No. 24 insulated wires, each about 1 yard long. They should be fastened to holes in the crossbars. To the set of two cells connected in series, attach these wires. Care should be taken to keep the free ends of the wires from touching. With a knife remove the insulation from the wires at two opposite points, and hang a three-volt lamp across. You will find that this lamp does not let through as much current (amperes) as the cells can produce. Each lamp requires about a half ampere. The thirty-five ampere ammeter is not sensitive enough to measure the current used by a single lamp.

1. How many amperes would three such lamps use? Attach three lamps in parallel on the line wires. Disconnect one of the

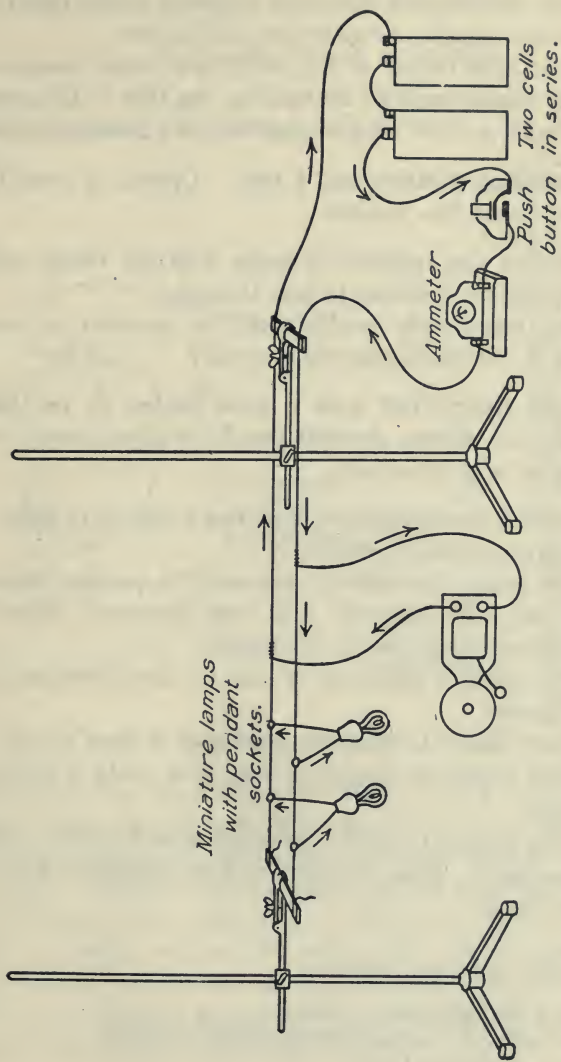

FIG. 21. — Wiring for miniature light and power system.

wires at the battery and attach the ammeter in the circuit. See if three lamps cause it to register any current flow.

2. If the total output of the two cells is fifteen amperes, how many such lamps could be operated at one time? Of course the battery would not last long at this rate of current consumption.

**B. Operating a Motor and a Bell.** Operate a small electric motor from your line current.

3. Connect the ammeter in series with the motor and note how much current it allows to pass through.

4. How many such motors could be operated at one time with a set of cells delivering ten amperes?

Attach an electric bell with a push button to the line and operate it. An electric doorbell usually requires about one-fifth of an ampere and three volts.

5. Which is more expensive — to ring a bell, or to light a lamp of the type used above? Why?

6. How many dry cells are necessary to produce three volts pressure? six volts pressure? nine volts pressure? How should they be connected, in series or in parallel?

7. How might a cell or set of cells be short circuited and the current wasted?

8. With respect to amperes, what does a short circuit mean?

9. With respect to length of wire, how could a short circuit be avoided?

10. With respect to kind of conductor, how could a short circuit be avoided? What is meant by high resistance wire, or high resistance lamp?

#### BOOKS FOR SPECIAL STUDY:

*Harper's Electricity Book* — Adams.

*Harper's How to Understand Electrical Work* — Onken.

*Physics* — Black and Davis.

## 22. ELECTROMAGNETS AND PERMANENT MAGNETS

To study magnets and magnetism.

MATERIALS. Dry cell; 3 ft. No. 24 insulated wire; large iron nail; small nails; compass; steel knitting rod; push button.

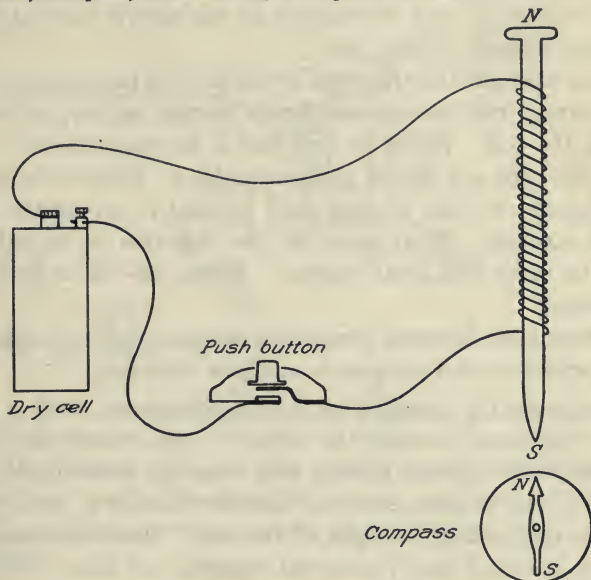

FIG. 22. — Apparatus for the study of magnetism.

Wind the wire around an iron nail, making about fifteen or twenty turns, connect it in series with the push button and note the effect on the small nails when ends of the wire are touched to a dry cell. (*Caution. Do not let the current flow through this short wire for more than a moment, as it would soon ruin the dry cell.*) With a compass, test for N. and S. poles of the magnet. The south pole of the coil will attract the north pole of the compass. Reverse the direction of current by interchanging the ends of the wires on the dry cell and retest for poles.

1. How is the polarity affected by reversing the flow of current?
2. Does a soft iron nail retain its magnetism when the current ceases?
3. State the law which applies to the attraction and repulsion of poles. These effects, discovered by Oersted, in 1819, have been the forerunners of such instruments as the electric bell, telegraph, telephone, dynamo, motor, etc.

Place a hard steel knitting rod, or old file, in a large coil and send direct current from the 110-volt line, a storage battery, or dry cells through the coil. Withdraw and test it for magnetism.

4. What can you say of its permanency? Refer to texts.
5. Should soft iron or hard steel be used in an electro- (temporary) magnet? What would be the objection to the other?
6. The earth is a great magnet. Where are the earth's magnetic poles?
7. Distinguish between permanent magnets and electromagnets.
8. Explain what a compass is and how it works.

To increase the strength of an electromagnet, send a larger current (amperes) through the turns of wire around the bar, or keep the same current flowing and wind on more turns. The product of the amperes (current) and the number of turns determine the magnetizing strength of the coil. Since electromagnets are more powerful than permanent magnets and since their magnetism can be quickly destroyed, they have been given a great many practical applications, such as electric bells, electric motors, electric generators, induction coils, telegraph, telephone, wireless, etc. Electromagnetic cranes are used in lifting heavy masses of iron in steel mills and in the manufacture of nails, bolts, etc. A large magnetic crane will lift two tons of iron at one time.

#### BOOKS FOR SPECIAL STUDY:

*Physics* — Black and Davis.

*The Boy Electrician* — Morgan.

*Elements of Electricity* — Timbie.

*How to Understand Electrical Work* — Onken.

## 23. THE ELECTRIC BELL AND THE TELEGRAPH

To study the operation of an electric bell.

MATERIALS. Electric bell; two dry cells; No. 24 insulated wire; push button.

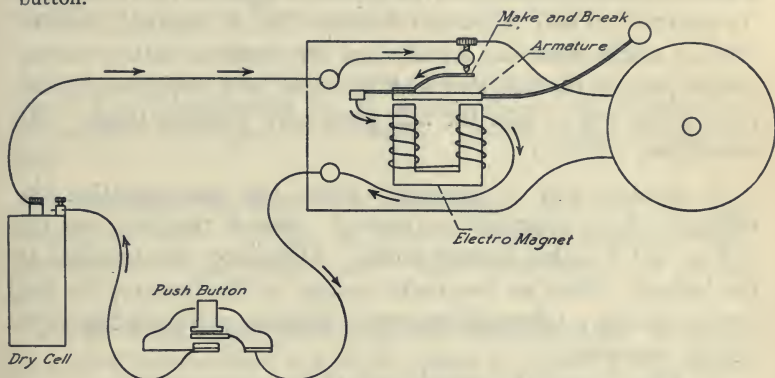

FIG. 23. — Path of the electric current in operating an electric bell.

A. **The Electric Bell.** In the vibrating bell, when the circuit is closed as a result of pushing the button, there is an arrangement in the bell which alternately closes and opens the circuit through the coils.

1. Diagram a bell, indicating the path of current through the bell by means of arrows. The path of the current is not exactly the same in all bells. See Mann and Twiss, Black and Davis, Millikan, Gale and Pyle.

2. What caused the tapper to move toward the bell?
3. What stops the flow of the current?
4. What causes the tapper to move away from the bell?
5. Diagram a circuit showing a battery, a push button, and a bell.
6. Diagram a battery and one push button operating two bells. The bells should be attached in parallel.

7. Diagram a circuit containing one battery and two bells, each bell being operated by an individual push button (front and back door).

**B. The Telegraph Receiving Instrument.** An electric telegraph instrument depends for its operation upon an electromagnet. An electric bell may be made to operate like a telegraph sounder (give a single stroke). Attach one wire from a battery to the proper post on the bell, and with the other wire, touch some other part of the bell so that the bell gives only a single stroke. (It should not vibrate.)

8. Explain why it does not vibrate. In this operation the bell acts like a telegraph instrument. Attach the wires on the bell so that it makes a single stroke. Disconnect one terminal at the battery. Now as you make contact at the battery, the bell should act like a telegraph receiver. Examine a regular telegraph receiver (sounder).

9. What causes the sounder-bar to move downward?

10. What causes the sounder-bar to move upward?

11. Why are bells and sounders made with two coils instead of one? See Millikan, Gale and Pyle — Electromagnet.

#### BOOKS FOR SPECIAL STUDY:

*Physics* — Mann and Twiss.

*Harper's Electricity Book* — Adams.

*Practical Physics* — Black and Davis.



## 24. ELECTROPLATING

**To electroplate a piece of carbon with copper.**

**MATERIALS.** Battery jar used for the Liquid Cell; carbon rod from a dry cell; strip of copper; copper sulfate; sulfuric acid; No. 24 insulated copper wires; three-volt direct current from two dry cells.

**NOTE.** — This experiment may be performed more economically if a 110-volt direct current is available by using a one-half ampere lamp as a resistance with each electroplating jar. If two dry cells are used do not fill the jar completely with copper sulfate solution. Fill it to a depth of about one inch.

**A. Copperplating Electrolyte and Wiring.** Make up a copper sulfate electrolyte. Weigh 20 grams of copper sulfate crystals and dissolve in 300 c.c. of water. Add about one c.c. of sulfuric acid.

**B. Wash the carbon thoroughly with scouring soap.** (*Caution. If 110-volt direct current is used, be certain to connect a half ampere lamp for resistance in series, as shown in illustration.*) Determine which terminal of the source of current is positive and which is negative, by attaching two wires and inserting the two ends into a tumbler of water containing about a quarter teaspoonful of table salt. If the current is of low voltage, use a small quantity of concentrated salt solution. The negative terminal gives the greater evolution of bubbles. (*Caution. Do not let these two wires touch, as a short circuit would result.*) Attach the negative terminal of the line firmly to the carbon electrode, and the positive terminal to the copper electrode. When the electrodes are properly attached, insert them into the solution of copper sulfate. Keep them as far apart as possible in order to prevent too rapid action. The carbon electrode should be turned at short intervals to insure an even deposit. If too much current is allowed to flow, the deposit will be spongy, or may contain some black oxide of copper. The best deposits are obtained when the action is very slow. Soon after inserting the electrodes, you should observe the grad-

ual depositing of the copper. If the apparatus is working properly the deposit should be a clean, brilliant copper color. Good

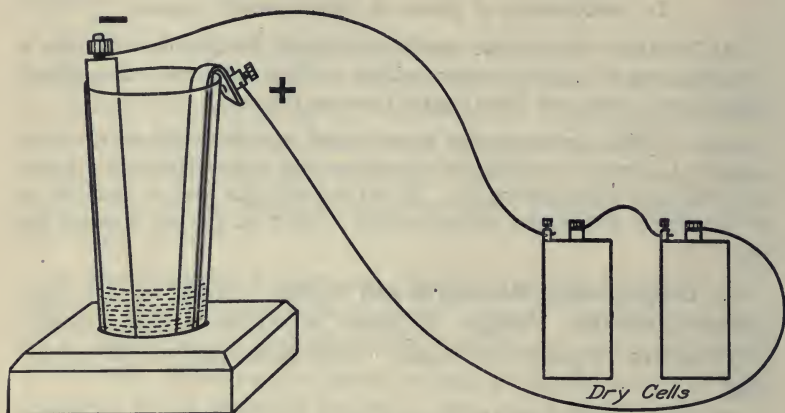

FIG. 24a. — Electroplating with dry cells.

results may be obtained with a six-volt current and a fifth-ampere flow. The process of plating should require from fifteen minutes to a half hour. Better results are obtained when the operation is slow.

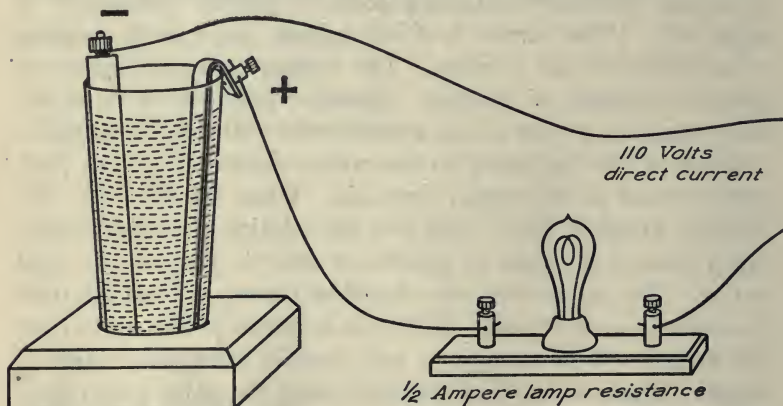

FIG. 24b. — Electroplating with 110-volt direct current.

**C. The Operation.** In the solution, the copper sulfate molecule separates into Cu ion and  $\text{SO}_4$  ion. The copper is drawn toward the negative electrode and deposits upon the carbon. The  $\text{SO}_4$  ion is drawn to the positive electrode and there attacks the copper plate, forming new  $\text{CuSO}_4$ . This action takes place as long as the electric current is flowing. The solution contains just as much  $\text{CuSO}_4$  at the end as at the beginning. The purpose of the sulfuric acid is to reduce the concentration of the copper ion and prevent the formation of copper oxide.

1. What was the purpose of the lamp in the circuit?

2. An ampere of current deposits one gram of copper in fifty minutes. If, in your experiment, the carbon rod receives three-twentieths of a gram of copper in thirty minutes, how many amperes were flowing?

**D. Removing the Copper.** When a good deposit is obtained, have the plated carbon approved by the instructor. Then interchange the electrodes on the wires, sending the current through the apparatus in the opposite direction.

3. Explain chemically what happens when the current is reversed.

4. Make a careful diagram of the apparatus and wiring.

5. How may knives and spoons be plated with silver? See Black and Davis, or Millikan, Gale and Pyle, or *Ontario Physics*.

6. In charging a storage battery, what compound of lead is formed on the positive plate? See Hoadley, Millikan, Gale and Pyle, or Black and Davis. When the storage battery is discharged, this deposit reacts with the solution in a manner similar to the action of a liquid cell.

A lead paper-weight may be copperplated as described above. Gold, silver, nickel, cobalt, platinum, and brass are among the metals that may be plated by the electrolytic process. A standard silverplating solution consists of potassium cyanide and silver

cyanide. The cyanide salts are more suitable electrolytes for rapid work, but they are dangerous on account of their poisonous properties. An object to be electroplated should be chemically clean. It should be thoroughly washed in both acid and alkali to remove every trace of foreign matter.

#### BOOKS FOR SPECIAL STUDY:

*Physics* — Millikan, Gale and Pyle.

*Practical Physics* — Black and Davis.

*Harper's Electricity Book* — Adams.

### 25. PINHOLE IMAGES

To study images projected through a pinhole.

**MATERIALS.** A cardboard having a pinhole and a large hole of one-quarter inch diameter, the two holes being located about two inches apart; small candle; cardboard for screen.

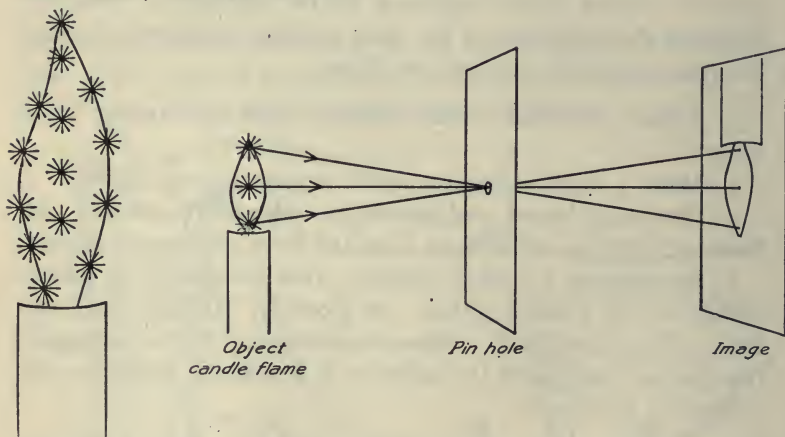

FIG. 25. — An image may be produced by light rays passing from a candle-flame through a pinhole.

Place a lighted candle in front of a piece of cardboard in which a small hole (as large as a pin head), has been punched. Hold a

second piece of cardboard (screen) behind the first and observe the images formed on the screen by the light rays which pass through the small hole. The infinite number of points which constitute the flame may each be considered a source of radiation from which light waves pass out in all directions. For simplicity in making diagrams, radiant energy may be represented as straight lines traveling in all directions from each point-source of illumination on the flame.

1. How does moving the screen farther back affect the image with respect to (*a*) size, (*b*) brightness?

2. How does moving the object (flame) farther from the small opening affect the image with respect to (*a*) size, (*b*) brightness?

3. Try a larger opening. What effect has the larger opening upon the image with respect to (*a*) sharpness, (*b*) brightness?

4. Any number of light rays may cross at a point without undergoing change of direction. How does the fact that light rays travel in straight lines explain why the image is inverted? Make a simple diagram of the flame, the opening and the image with straight lines representing the rays of light. Reference, Mann and Twiss.

5. Explain the fact that a small opening makes a sharper (less blurred) image than a larger one.

6. Explain the fact that a large opening makes a brighter image.

7. Diagram a pinhole camera. See Hoadley.

#### BOOKS FOR SPECIAL STUDY:

*Physics* — Mann and Twiss.

*The Wonder Book of Light* — Houston.

*General Science* — Hodgdon.

## 26. LENS IMAGES

To study images projected by means of a lens.

MATERIALS. Small candle; convex lens; screen.

A pinhole may be considered as permitting only a few rays from each point on the flame to pass through the hole, casting its illumination on the screen. A lens, on the other hand, receives

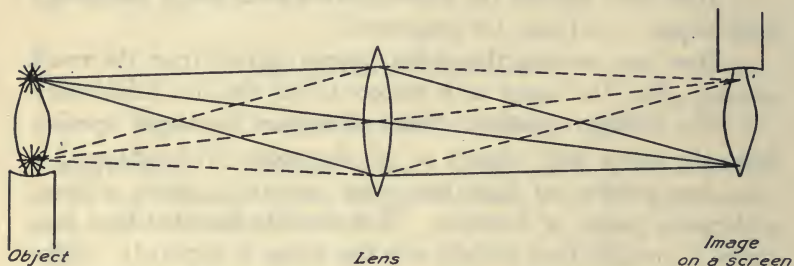

FIG. 26. — How light rays from two points on a flame are focused by a lens producing an inverted image.

many more rays from each point on the flame and focuses them to corresponding points on the screen. It should be remembered that light travels by means of waves. Rays, or lines, are used for convenience and simplicity. Thus each one of the infinite number of points on the flame is represented by a corresponding point of illumination, which is produced on the screen by the refraction and focusing of the light rays. The accompanying diagram shows how the lens receives light from two such points. Two cones of light radiation strike the face of the lens and are focused to two points on the screen. For convenience in diagraming, the cone of radiation from each point is represented by simply three lines.

Place the lens between the candle and the screen and move the candle and screen into such positions that a sharply focused image is formed.

1. Move the candle and the screen so that the image is the exact size of the object. How do the distances of the object from the lens and of the image from the lens compare when the object and the image are equal in size? What is this distance in inches in the case of this particular lens?

2. How does the lens image compare with the pinhole image with respect to (a) brightness, (b) sharpness? Explain these differences.

3. Diagram two cones of light radiation proceeding from two points on the flame striking the surface of the lens and being focused to two points on the screen. This may be represented by three lines of light from each point, one through the center of the lens with no change of direction, and two rays striking near opposite edges of the lens and refracted to a common point on the screen. See illustration.

4. If the lens remains stationary and the screen is moved farther away, what change in the position of the object must be made to produce a sharp image? What change does this make with respect to size and brightness of the image?

5. If the lens remains stationary and the screen is moved closer to the lens, what change must be made to produce a sharp focus?

6. Is it possible to place the object and the screen in a stationary position and focus by moving only the lens? In focusing the ordinary camera and the projection lantern, what is moved?

7. Diagram object, lens, and image, showing proper proportions of object and image when the object (flame) is placed *closer* to the lens than in No. 1.

8. Diagram object, lens, and image, showing proper proportions of object and image when the object (flame) is placed *farther* from the lens than in No. 1.

#### BOOKS FOR SPECIAL STUDY:

*Physics* — Mann and Twiss.

*How to Make Good Pictures* — Eastman Kodak Co.

*The Wonder Book of Light* — Houston.

*Photography of To-day* — Jones.

## 27. LAW OF REFLECTION

To prove that when light is reflected from a mirror the angle of incidence equals the angle of reflection.

**MATERIALS.** Nickel-plated mirror; two small candles; two pins; sheet of paper; protractor.

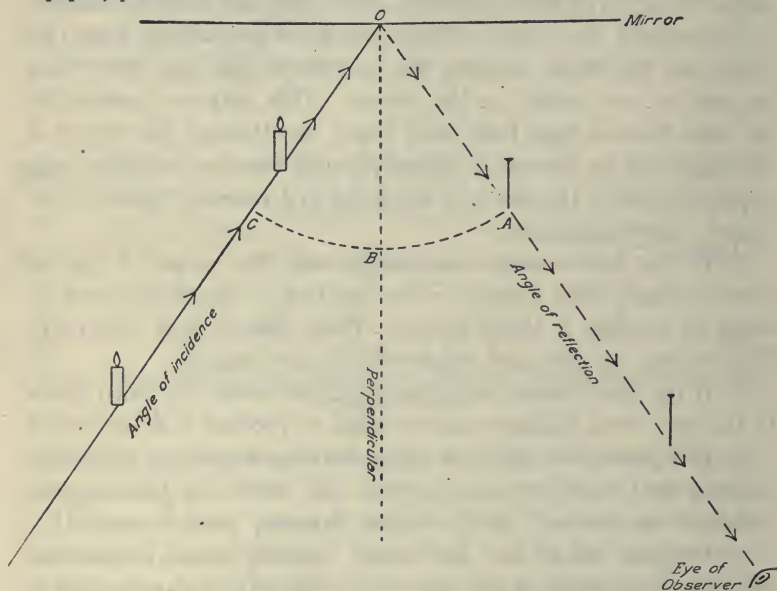

FIG. 27. — Diagram showing the path of light rays from two candle flames striking a mirror and being reflected to the eye of an observer.

Stand the mirror near the center of the sheet of paper facing toward the bottom, and draw a line along the front of the mirror representing its edge. Draw a second line from one of the lower corners till it strikes the mirror line at about its midpoint. Stand two small candles, each about one inch long, on the paper about four inches apart, with their centers directly over the line which strikes the mirror. Now place your eye in proper position to



observe the images of the candles and the line in the mirror, so that the image of one candle appears directly behind the other. Continue the image of the candle line by a line on the paper from the mirror toward your eye. The two lines should intersect at the edge of the mirror. When the eye is in position near the level of the paper, the lines drawn represent the path of light rays coming from the candles to the eye. Light from the candles has struck the mirror and has been reflected in the direction of the line toward the eye of the observer. This reflection of the rays of light causes the light to appear to come from beyond the mirror, where the candles appear to be located. The candles appear to be as far back of the mirror as they actually are in front of it.

1. Using the protractor, erect a perpendicular at the point where the two lines strike the mirror. Measure in degrees on the protractor the angle of incidence and the angle of reflection (angles between the oblique lines and the perpendicular), and note how angle  $BOA$  compares in size with angle  $BOC$ . Read texts on reflection.

2. Repeat the experiment by changing the size of the angles and make a new set of measurements. NOTE. This experiment may be done with pins in place of the two candles as directed above.

3. If the angle of incidence is made larger, how does this affect the angle of reflection?

4. When you stand at the left of a mirror which hangs on the wall, in what position must a second person stand in order that you may see each other in the mirror?

5. When a mirror hangs perpendicularly on the wall, what is the highest point between the level of the observer's eyes and the floor at which the bottom of the mirror may be placed in order that he may see his feet in the mirror? Test it. Make a diagram as proof of your conclusion.

6. Diagram a ray of light from an object striking the surface

of a mirror and being reflected to the eye of an observer. See *Household Physics*, Butler, or *Ontario Physics* — Reflection.

7. Diagram rays of light from a tree on one bank of a pond striking the water and being reflected to the eye of an observer, showing how the rays may cause the tree to appear inverted in the water.

8. Diagram light rays reflected to a focus by a parabolic mirror. See Black and Davis, or Carhart and Chute.

Objects appear to be located in the direction of the last straight-line-path of light approaching the eye. No matter how many times the direction of light rays from an object have been changed by reflection or refraction, the eye receives the light as if the object were located in the direction of the rays which finally enter the eye.

#### BOOKS FOR SPECIAL STUDY:

*General Science* — Barber.

*Physics* — Black and Davis.

### 28. THE LAW OF INTENSITY

To prove that if the distance of an object from a light source is doubled, the light which strikes a given area on the object is one-fourth as intense.

**MATERIALS.** Candle flame; card with hole one inch square; cardboard screen scored with sixteen one-inch squares; ringstands and clamps.

**Law of Intensity.** The intensity of illumination varies inversely as the square of the distance from the source of light. The area of the surface illuminated varies directly as the square of the distance.

Place the card with one-inch square hole one foot from the flame, and the screen one foot beyond the first card (two feet from the flame). The light from the candle will shine through the one-inch opening and illuminate the screen.

1. Measure the area of the space illuminated on the screen when the screen is twice as far from the source of light as the one-

inch hole. Note that the light which passes through the one-inch hole spreads to four times the area of the hole.

2. Move the screen three times as far away from the flame as the one-inch hole and demonstrate the law. State the result with regard to intensity for this distance. State the result with regard to the surface illuminated.

3. How does the intensity of illumination two feet from a source compare with the intensity eight feet from the same source?

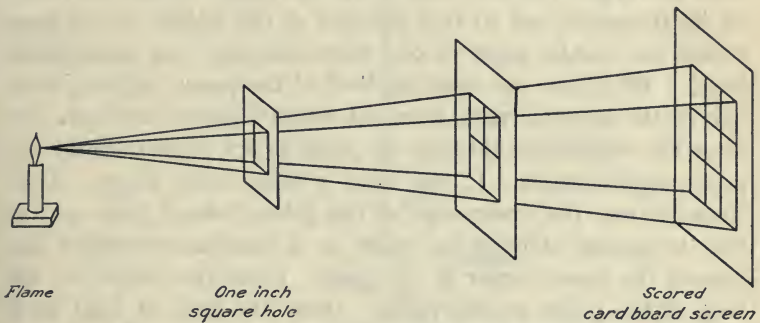

FIG. 28. — Diagram showing the areas covered by light which passes through a one-square-inch opening.

4. In a school room or home, how does the illumination which a book receives from a window at a distance of four feet, compare with the illumination which the book receives from the same window at a distance of twelve feet? The law applies here approximately the same as for a candle. If in this case the distances are as one to three, how do the intensities of illumination compare?

5. Make a diagram showing how light radiates from a point-source through a one-inch square opening, one foot from the source. Show the surface illuminated at two feet, at three feet, and at four feet.

#### BOOKS FOR SPECIAL STUDY:

*General Science* — Hodgdon.

*Modern Illumination* — Horstmann and Tousley.

## 29. THE PRISM AND THE LENS — REFRACTION

To demonstrate the refraction of light at the surfaces of a glass prism.

**MATERIALS.** Glass prism; rule; protractor; sheet of paper; double convex lens (reading glass lens).

From about the middle point on the upper edge of the paper, draw a straight line half way down the page. Stand the prism on its triangular end so that the line at the middle of the page strikes the middle point of one edge obliquely (not perpendicularly). With your eye near the level of the paper, sighting from one of the lower corners, turn the prism slightly until you observe the original line through the prism as if it came from the opposite upper corner. It will have a faint color fringe. Continue it from the lower edge of the prism toward your eye, so that it appears through the prism as a continuous straight line toward the lower corner of the page. Draw the outline of the base of the prism on the paper. Draw the path of light as it passes between the edges of the prism.

**Explanation:** Any visible object is seen by reason of light rays coming from it to the eye. When the eye sees the line through the prism, it is due to the fact that the light rays are coming from the line through the glass to the eye. If the line appears to be in some unexpected direction, it must be due to a change in direction of the light ray caused by its passing through the prism.

1. Extend the first line and with a protractor measure in degrees how much the prism refracts the light ray from its original course. Explain the cause of refraction. See Carhart and Chute. If convenient, hold the prism in the sunlight and see how the sun's rays, which strike it, are thrown out of their course. Note that the refracted rays are not white light, but the prismatic colors. When a light ray is refracted by a simple prism, or lens, it also undergoes dispersion into its component color rays.

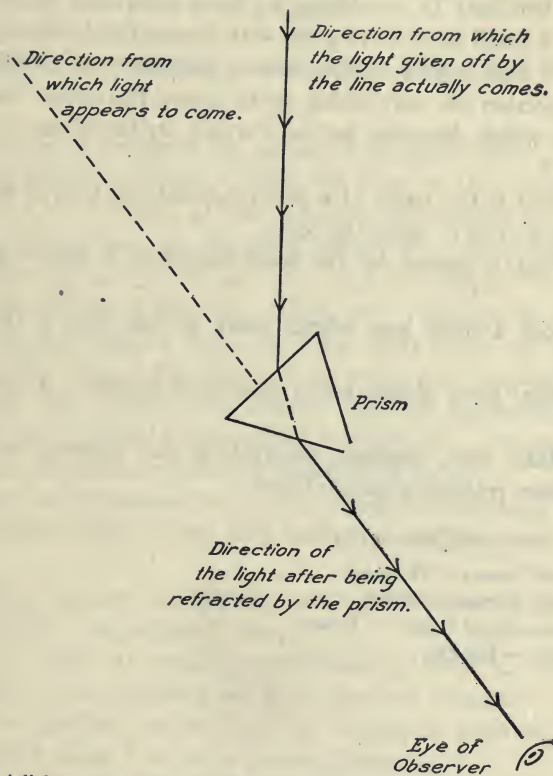

FIG. 29. — A light ray is refracted by a prism causing it to appear to the eye to come from a different direction.

2. What is meant by the term dispersion? See texts.
3. Is a light ray refracted toward the thicker part or toward the thinner part of the prism?
4. A lens may be considered as being composed of an infinite number of small sections of glass with non-parallel sides (prisms). When the lens is held in the path of parallel rays (sunlight), in which direction are rays which strike above the center refracted?
5. In which direction are rays which strike below the center refracted?
6. What is the name of a point beyond the lens at which all of the rays cross? Refer to texts.
7. What is meant by the focal length of a lens? Refer to texts.
8. Does a thick lens refract more or less than a thin lens? Explain.
9. What form of lens has a long focal length? A short focal length?
10. Make two diagrams illustrating the answers to No. 9. Show lenses refracting parallel rays.

BOOKS FOR SPECIAL STUDY:

*General Science* — Hodgdon.

*General Science* — Barber.

*Photography of To-day* — Jones.

*Physics* — Hoadley.

## 30. THE GLASS CUBE AND THE LENS — REFRACTION

## Refraction at the surface of a glass cube and at the surface of a lens.

**MATERIALS.** Glass cube; rule; paper; reading glass lens (double convex).

Beginning at the upper left corner of the paper, draw a diagonal half way across the paper. Place the cube on this line, at about the center of the page, so that its sides are parallel to the edges of the paper and the diagonal strikes the upper edge of the cube about a quarter of an inch from the upper left corner. Draw the outline of the cube. Now with your eye on the level of the paper, sighting from the lower right corner of the paper, observe the original line through the cube and continue it from the lower edge of the cube toward your eye so that it appears through the cube as a continuous straight line. Draw the path of light as it passes between the edges of the cube.

Repeat the experiment with the original line striking the cube at the middle point of one edge and perpendicular to it.

1. What happens to light rays when they enter the glass at an oblique angle (not perpendicular)?
2. If a light ray passes perpendicularly from air through a glass object with parallel sides, is its direction changed?
3. If a light ray passes from air through a glass object with non-parallel sides, how is its course affected?
4. Draw cross sections of a double convex lens and a plano-convex lens. See Hoadley.
5. Explain the fact that the light ray (wave) which strikes perpendicular at the center of a lens, passes through without being deviated from its original direction. See Black and Davis — Refraction.

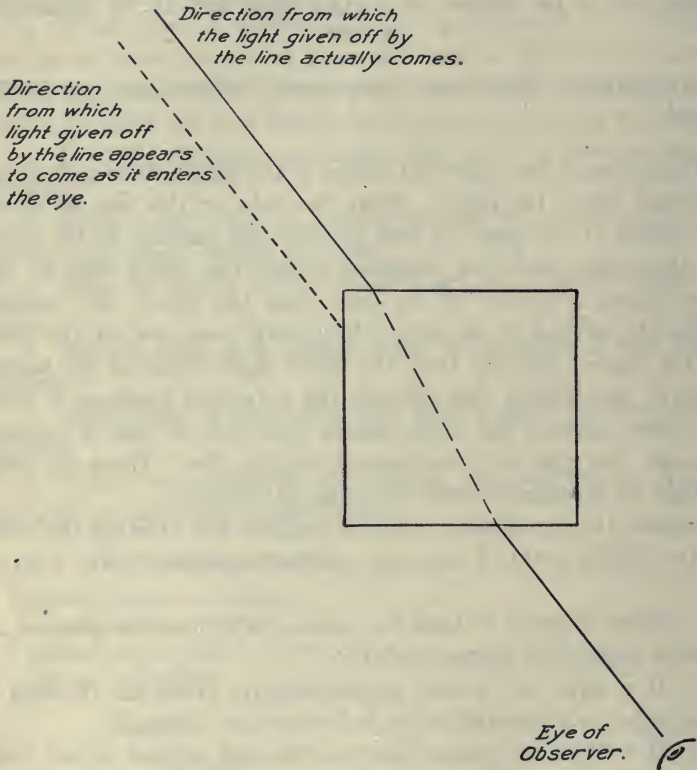

FIG. 30. — A light ray is refracted when it enters a glass cube at an oblique angle (not perpendicular). It is again refracted when it passes out at the opposite side.



6. What happens to a light ray (wave) which passes through any point other than the center? See Black and Davis.

7. In what region of a lens does the greatest refraction occur? Explain.

8. Draw a lens and show three rays of light striking it from some one point, illustrating any refraction that may take place. Show one ray passing through at the center and the others near two opposite edges.

9. Diagram a lens showing how the lens affects parallel rays as in the case of rays from the sun.

NOTE: In cases of refraction the bending of the light ray takes place at the surface, not inside the glass. Note, also, that refraction is greater if the approaching ray enters the glass more obliquely. Refraction occurs, in general, when a light ray passes obliquely from one medium to another of different optical density. Refraction occurs as the ray enters the glass and again on the opposite side as it leaves the glass. The eye, in seeing, assumes that an object is in the direction of the light ray which immediately enters the eye, regardless of any previous refractions of the ray.

BOOKS FOR SPECIAL STUDY:

*General Science* — Hodgdon.

*Physics* — Hoadley.

*Light, Visible and Invisible* — Thompson.

## 31. ILLUMINATION AND LIGHTING

**MATERIALS.** 5 small candles; ring stand; clamp; white cardboard screen; ruler; wood blocks for candles; dark room.

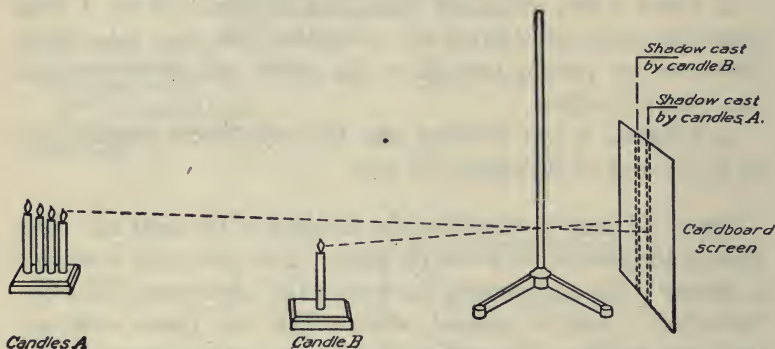

FIG. 31.—A Rumford photometer—a simple device for comparing the brightness of one light source with another.

#### A. Intensity of Light in Relation to Distance from its Source.

Set up the white cardboard screen vertically, and place the upright rod of the ring stand about three or four inches in front of it. Two feet from the screen place a block with four candles (*A*) arranged one behind the other with respect to the screen. See instructor's model. A shadow will be cast on the screen back of the ring stand rod. Place a single candle (*B*) in such a position that another shadow from the same rod will be cast close to the previous shadow. Note that candles (*A*) illuminate (shine upon) the shadow of candle (*B*), and that candle (*B*) illuminates the shadow cast by candles (*A*).

1. When the two sources of light are placed equidistant from the screen, if the shadow cast by the four candles (*A*) is illuminated less than that cast by the one candle (*B*), which source gives the more light to the screen?

2. How will the shadows compare in brightness when the screen

receives equal illumination from the two sources? This device is known as a Rumford Photometer.

3. When the shadows are equally illuminated, measure the distance from each source of light to the shadow which it illuminates, not the one which it makes.

4. If a source of light is moved twice as far away from an object, how much brighter must the light be made to illuminate the object to the same degree as before?

5. If *A* reads a book at a distance of three feet from a table-lamp and *B* reads a book at a distance of six feet from the same lamp, how do their illuminations compare?

6. State the Law of Inverse Squares with respect to intensity of illumination. See Mann and Twiss, Hoadley, or Black and Davis. The same law applies to the intensity of sound, the attraction of gravitation, and magnetism with respect to distance.

**B. Indirect Lighting.** When electric lamps or gas lamps are fitted with reflectors, placed underneath for throwing an intense illumination evenly over the white ceiling of a room, the effect is known as indirect lighting. In this case the light from the lamp is not visible directly, but by reflection from the ceiling. This lighting scheme supplies a soft and pleasing effect, but it requires a large amount of light and is, therefore, expensive.

**C. Semi-indirect lighting** results from the use of large ornamental glass diffusing shades, placed under a brilliant electric, or gas lamp. This system has met with great popularity in recent years in home lighting as well as for other special lighting purposes.

**D. Direct lighting** refers to the older method of obtaining illumination directly from the light source.

BOOKS FOR SPECIAL STUDY:

*Modern Illumination* — Horstmann and Tousley.

*Practical Physics* — Black and Davis.

*General Science* — Barber.

## 32. CANDLE POWER AND FOOT-CANDLES

To measure the candle power of a lamp.

**MATERIALS.** Candle; ring stand; white cardboard screen; ruler; block; small 3-volt incandescent lamp; two dry cells; dark room.

**A. Photometer.** Set up a Rumford photometer as described in experiment No. 31. See instructor's model. Substitute for the four candles a small incandescent lamp connected with a two-cell battery. Adjust until the one candle and the small incandescent light shine, as nearly as you can judge, with equal intensity upon the shadows. If the two light sources to be compared give lights of different colors, as in this case, the judging of equal intensity will be more difficult than when the lights are of the same color. Make three or more independent judgments and average the results,

1. Compute the candle power of the lamp. (Their candle powers will compare directly as the squares of their distances from the screen.)

2. A candle stands one foot from the screen and a large electric lamp stands ten feet from the screen. If the shadows produced by the two sources are equally illuminated, what is the candle power of the lamp?

**B. Light and Illumination.** The arrangement, the number, as well as the kind of lights, to be used in various rooms must be considered in the problem of room lighting. There are two general factors in any lighting scheme; the brightness of the lights themselves (candle power) which makes looking at them either painful, or tolerable to the eye; and the illumination given to a room, which is gauged by the clearness with which the objects in the room can be seen. A light source may be very bright (of great candle power) and yet it may not illuminate properly because

of misdirected rays, improper shades, the color of the walls, or other light-reflecting or light-absorbing agencies. The intensity of the light which falls upon an object is measured in foot-candles. A foot-candle is the intensity at a distance of one foot from a source of light of one candle power in value. At a distance of two feet, according to the law of inverse squares this same source would give an intensity of only  $\frac{1}{4}$  foot-candle, at three feet,  $\frac{1}{9}$  foot-candle and so on.

**C. Rules for Determining Candle Power and Foot-candles for Reading.** Three foot-candles of light are considered adequate intensity for ordinary reading purposes.

*To find the foot-candles which fall upon an object, divide the candle power of the source by the square of the distance in feet which the object is from it.*

*To determine the candle power of the lamp to be used for reading, square the distance from the lamp and multiply by three.*

*To determine how far to sit from a lamp for reading, divide the candle power of the lamp by three and extract the square root.*

3. What intensity in foot-candles would be supplied for reading by a 16 candle power lamp at a distance of 4 feet? Two feet?

4. If a 3 candle power lamp is adequate for reading at a distance of one foot from the lamp, what candle power should be provided for reading at a distance of five feet?

5. How far from a forty-eight candle power lamp should one sit for reading?

**BOOKS FOR SPECIAL STUDY:**

*Modern Illumination* — Horstmann and Tousley.

*General Science* — Barber.

*General Science* — Hodgdon.

*Practical Physics* — Black and Davis.

## 33. COLOR

To determine the composition of sunlight and study the spectrum colors.

**MATERIALS.** Glass prism; ring stand and clamp; reading glass lens; cardboard screen.



FIG. 32. — The prism refracts and disperses the light. The lens combines the color rays again, producing white light — analysis and synthesis of sunlight.

**A. Analyzing Sunlight. — The Prismatic Colors.** Set the prism horizontally in a ring stand clamp in the sunlight, so that one of the long edges points downward. Place paper or rubber tubing between the prism and the clamp to protect the glass. The white sunlight which strikes one face of the prism will be broken up into its component colors. These colors represent the different vibration rates which combine to make sunlight or white light. Hold a cardboard screen in the path of these colors, about six or eight feet from the prism. Darken the room as much as possible.

1. What three general color effects do you notice? These colors shade off into various other tints. What are the three primary colors? See Carhart and Chute, Millikan, Gale and Pyle, Mann and Twiss.

2. Name the seven colors of the rainbow as ordinarily listed. Hold a lens in front of the screen in the path of these color rays at the proper distance from the screen to bring them to a focus and reunite them on the screen.

3. What is the color of the image?
4. What conclusion do these facts suggest regarding the nature of sunlight? See Millikan, Gale and Pyle, Carhart and Chute, Black and Davis. When the colors are focused to white light on the screen, note that you have on the screen an image of the illuminated prism, rectangular in shape.
5. What is the distance in inches from the image to the lens?
6. When the screen is moved further back from the point of focus, what changes do you note in the order of colors? Explain.
7. Which color of light does the prism refract more, blue light or red light? Blue light represents a vibration rate about twice as rapid as red light. Light waves produced by the more rapid vibration rates are refracted more than those from slower vibration rates.

**B. Color.** Colors are produced by the effects of different vibration rates upon the optic nerve. The visible colors range from the violet at one end of the spectrum to the red at the other end. The vibration rates which produce these effects range from approximately four hundred million million per second for red light, to seven hundred million million per second for violet light. Other radiation such as heat is too slow to be seen, while ultra violet light and X-rays are too rapid to be seen by the eye.

Different light sources such as sunlight, gas light, lamp light, electric light, all represent different combinations of colors. Artificial lights in general have less blue than sunlight. The mercury vapor lamp, however, is an exception to this rule. It gives a greater percentage of blue than sunlight.

**BOOKS FOR SPECIAL STUDY:**

*Physics* — Mann and Twiss.

*General Science* — Hodgdon.

*Light, Visible and Invisible* — Thompson.

*Physics* — Hoadley.

## 34. ABSORPTION AND LIGHTING

To study absorption of colors.

**MATERIALS.** Glass prism; ring stand and clamp; cardboard and screen; transparent gelatine color-screens, red and blue; red cloth and blue cloth.

**A. Color Absorption.** Place a red transparent gelatine sheet in the path of the color rays from the prism as set up in the preceding experiment. If one gelatine sheet is too thin combine several sheets.

1. What color or colors are absorbed when white light passes through a red transparent medium?

2. When sunlight strikes a piece of red cloth, which of the prismatic colors are absorbed? Which is reflected?

3. Use pieces of blue gelatin and pieces of blue cloth and explain. In the same way try any other colors that are available, and explain the results.

4. What causes a blue object to look blue in sunlight? Which of the three prismatic colors, red, green and blue, does a red transparent sheet, or screen, placed in front of a blue piece of cloth absorb? If sunlight had no blue rays in it, how would a blue cloth appear?

5. What colors are absorbed by a piece of blue cloth?

6. If all other light is cut off from a blue cloth, except what comes through a red transparent screen (red light), why does the blue cloth tend to look black?

7. Place a piece of blue cloth or a blue gelatine sheet under a red gelatine sheet and observe its color. Explain.

8. What effect would blue walls, blue window glass, and blue lamp shades, have upon the color of a red dress?

9. What effect would red walls, red window glass, and red lamp shades have upon the color of a blue dress?

10. Incandescent electric, gas and oil lights are generally defi-



cient in blue rays. What effect has this upon the color of a blue dress?

11. When observed in ordinary artificial light, why do some colored articles of cloth appear different from their appearance in daylight?

12. If it were possible to get artificial light with the same color proportions in it as sunlight, what advantage would be obtained in observing colors? This effect is now obtained almost perfectly by combinations of colored lights with color absorption globes.

**B. Color Photography.** One successful method of producing color photographs involves taking three different exposures through different transparent color screens (red, yellow, blue). The three negatives thus obtained are used for making three color prints of the three colors — red, yellow, blue. When these three color prints are superimposed the result is a beautiful photograph in natural colors. The Lumière Autochrome Plates represent another method of color photography. The picture is produced directly on a plate which has been especially treated with an emulsion containing fine starch particles of red, green, and blue. The color photograph is developed directly on this plate and cannot be removed from it. It must be observed by holding it up toward the light or by hanging it against a window.

#### BOOKS FOR SPECIAL STUDY:

*General Science* — Hodgdon.

*Photography of Today* — Jones.

*Modern Illumination* — Horstmann and Tousley.

## 35. TUNING FORK AND VIBRATING AIR COLUMN

To determine the rate of vibration of a tuning fork (number of vibrations per second) by means of a vibrating air column.

MATERIALS. Hydrometer jar; lamp chimney; tuning fork; ring stand.

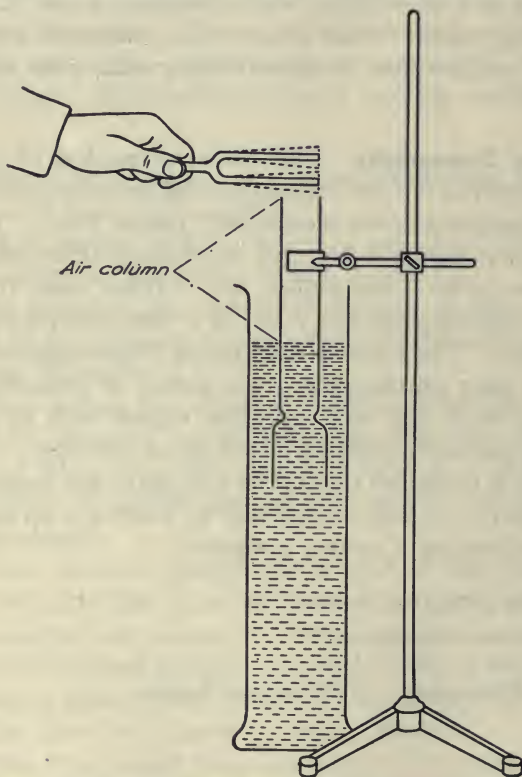

FIG. 33. — An air column of proper length vibrates in sympathy with a tuning fork.

A. Determining the Pitch of a Tuning Fork. Fill the jar nearly full of water. Support the lamp chimney on a ring stand

so that one end reaches into the water. This furnishes an air column closed at one end (by water). At the same time it is possible to increase or decrease the length of the air column by raising or lowering the chimney in the water.

When a tuning fork vibrates at the mouth of such an air column the tone of the fork may be loudly reinforced. This reinforcement occurs only when the proper length of air column is obtained. Move the chimney up and down till you find the exact length of air column which gives the loudest response to the tone of the fork. If the air column is comparatively narrow, this definite length furnishes a basis for determining how many vibrations the fork makes per second. Measure very carefully the distance between the top of the glass tube and the water level. Add one-third of the inside diameter of the tube as a correction for the width of the air column. Multiply this result by four, reduce to feet and divide into eleven hundred and thirty feet (the velocity of sound per second in air). This result is the vibration rate per second of the tuning fork. Make three separate determinations as a check to your work and average the results.

**B. Explanation.** The air column in a tube closed at one end acts like a coil spring fastened firmly at the bottom. If the air column is of just the proper length it can vibrate at the same rate as the fork and reinforce the fork. The air column vibrates in sympathy with the fork and makes the tone louder. A sound wave travels down the air column, strikes the water, rebounds, and returns to the top of the tube in the time of half a vibration of the fork. Sound, therefore, travels twice this distance down and back in the time of a complete vibration of the air column. This means that sound travels four times the length of the tube in each vibration of the air column and of the fork. In a second, then, there are as many vibrations as this distance is contained in eleven hundred and thirty feet.

1. What length of air column reinforces the fork which you used?
2. What is the vibration rate of the fork which you used according to your calculations?
3. How far does sound travel in the time of one vibration of this fork? Include correction for diameter.
4. What is meant by the wave length of a tuning fork? See Mann and Twiss, Carhart and Chute, or *Ontario Physics*.
5. Does a fork of high pitch require a long tube or a short tube for reinforcement? Explain.
6. Does striking a tuning fork harder change its pitch? How could you prove this?
7. If a tuning fork vibrates five hundred and twelve times per second what length of air column is required to reinforce it? Disregard width of air column.
8. Diagram the apparatus used in this experiment.

If a flat stream of air is directed properly across the end of this air column it will set the air in vibration similar to that of an organ pipe. As an organ pipe or whistle it will produce the same tone as the fork, provided the air column has the same length as that which reinforces the fork.

9. What kind of pitch would you expect to obtain from a very long pipe-organ pipe?

#### BOOKS FOR SPECIAL STUDY:

*General Science* — Hodgdon.

*Physics* — Hoadley.

*Sound and Music* — Blaserna.

## 36. THE VIBRATING STRING

To study musical tones produced by a vibrating string.

**MATERIALS.** 3-foot ring stand; No. 22 piano wire, length thirty-one inches, with one-inch rings attached at the ends; six screw clamp holders; yardstick.

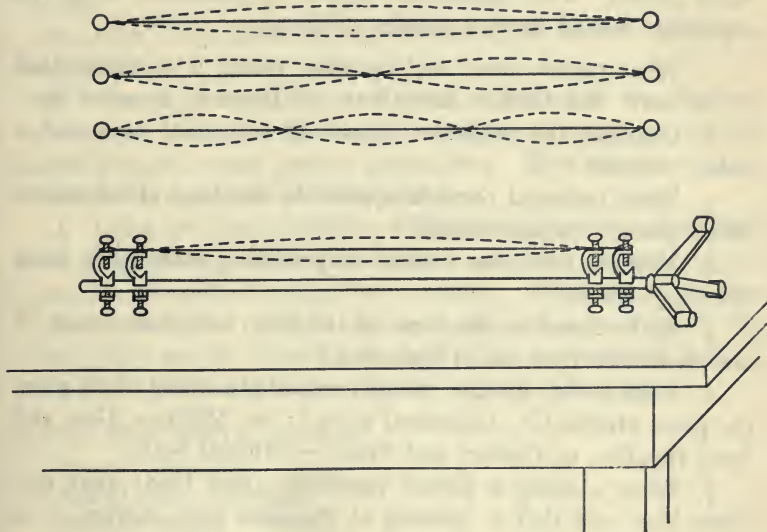

FIG. 34. — Apparatus for studying the vibrating string.

**A. Mounting the String.** Lay the ring stand down lengthwise on the table. Screw one clamp holder tight against the bottom of the stand rod. Put a second clamp holder on loose at the top of the stand rod. If the thumb-screw of the top clamp holder is loose enough it will lean toward the bottom when the ring is slipped over it and stretched tight. (*Caution. Keep your eyes at a safe distance from the string, as there is danger of injury in case the string should break.*) Tighten the upper clamp and as the

clamp holder straightens into position the string should become tight. If you have any difficulty in making the string tight, ask the instructor to help you. Place two other clamp holders near the first two so that the string is exactly thirty inches long between the last two clamp holders. Clamp them tight and turn them so that they press upon the string at two points exactly thirty inches apart. The string should then give a clear musical tone when picked. This experiment should be performed with the apparatus resting upon a wooden table top.

1. What causes sound and by what means is it transmitted to the ear? See Carhart and Chute, or Hoadley, or other text.

2. Compare the respective causes of a musical tone and a noise. Explain.

3. What technical name is applied to the kind of vibrations which produce musical tones?

4. Mention one other method of producing tones aside from vibrating strings.

5. With respect to the cause of the tone, how does a tone of low pitch differ from one of high pitch?

6. What is the vibration rate per second of a string which gives the pitch Middle C? (Standard pitch.) See Millikan, Gale and Pyle, Hoadley, or Carhart and Chute — Musical Scale.

7. When a string is picked vigorously (very loud) what evidence have you that it vibrates at the same rate as when it is picked lightly?

#### *B. Loudness.*

8. Explain the fact that a string picked harder produces a louder tone. What causes loudness?

9. Lift the apparatus from the table and pick the string. Do you notice a difference in loudness when the apparatus is held in your hand? Explain. See Carhart and Chute — Resonance.

10. What parts of the following instruments serve to intensify the tones — piano, guitar, Victrola?

### C. The Pitch of a String.

11. Place a clamp holder at the middle of the rod, dividing the string into two parts of fifteen inches each. Pick the string. The musician calls this tone an octave higher. What does the term octave mean with respect to vibration rate? State the law which applies to the length of a string? Name two instruments which illustrate this law. See Carhart and Chute — *Laws of Strings*.

12. How is the vibration rate affected by (a) tension, (b) thickness, (c) weight? Refer to texts.

13. Place a clamp holder at a point one-third of the distance between the two ends, dividing the string into two parts, one ten inches long, the other twenty inches long. How are these tones related with respect to vibration rate?

14. Using two clamp holders, divide the thirty-inch string into three parts, twelve inches, ten inches, and eight inches. Sound these three lengths of strings in succession. What are the names of these three notes? If you do not know, ask a musician in the class. How are the vibration rates of these tones related mathematically? See Carhart and Chute — *Laws of Strings*.

#### BOOKS FOR SPECIAL STUDY:

*Physics* — Hoadley.

*General Science* — Hodgdon.

*Household Physics* — Butler.

*Sound and Music* — Blaserna.

## GROUP II. EXPERIMENTS

## 37. BLOOD PRESSURE

To determine the pressure of the blood.

**MATERIALS.** Manometer tube with millimeter scale; two pieces of rubber tubing; small air pump; T-tube; screw clamp; pressure sleeve; mercury.

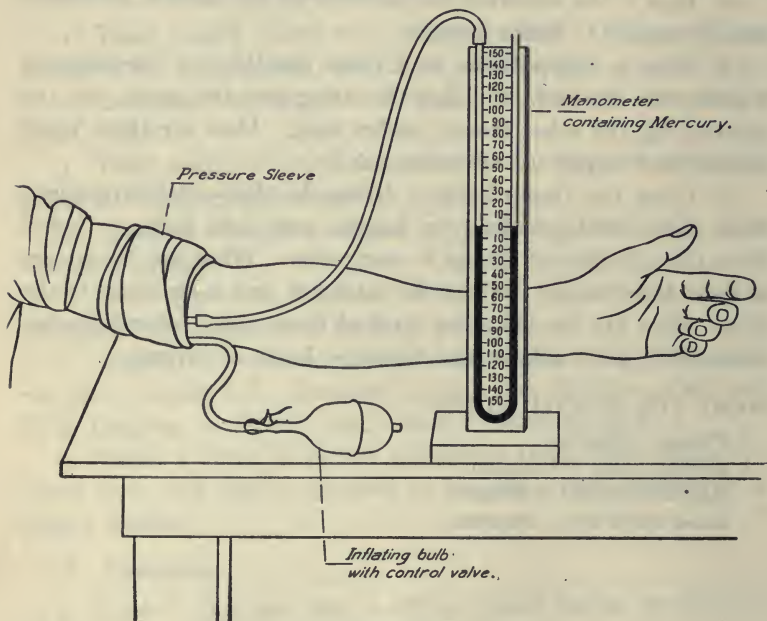

FIG. 35. — Measuring blood pressure.

**A. Setting Up the Apparatus.** The U-tube should be half full of mercury. Attach the T-tube to a clamp on a ring stand. Connect the arm of the U-tube to the T-tube by means of a rubber sleeve and to the third arm attach an air pressure pump. The



pressure bag consists of a rubber bag ten inches long and six inches wide covered with cloth.

NOTE: If the pressure sleeve is made similar to that shown in the illustration the T-tube should be omitted.

**B. Applying the Sleeve.** Sit completely relaxed in a chair. Place the part of the sleeve containing the rubber bag on the inside of the left arm above the elbow. (Ordinarily it is not necessary to bare the arm.) Wrap the remainder of the sleeve around like a bandage and tuck the end under the preceding fold. Pump enough air into the bag to cause the pulse to disappear. (About 200 millimeters of mercury.) The artery wall is compressed and the flow of blood is shut off. Quickly close the screw clamp and remove the pump. Allow the air to escape gradually from the bag by slowly opening the screw clamp. The reappearance of the pulse may be detected by observing the pulsation of the mercury column. It is very faint at first, and it increases to a maximum throb when the pressure in the bag is the same as the pressure in the artery. When this maximum throb is reached, measure the difference in levels in millimeters. This is the systolic pressure. Make three determinations and average the readings.

1. What is your systolic pressure in millimeters of mercury?
2. Make a careful diagram of the apparatus.
3. When the pulse first reappears, how does the pressure in the artery compare with the pressure in the rubber bag?
4. Would you expect the blood pressure at the feet to be greater or less than that at the head? Explain.
5. When a person faints or feels faint, why should the head be placed low?
6. If a man's blood pressure is one hundred and forty millimeters of mercury, to what height would his heart pump a column of water? (Mercury is thirteen and six-tenths times as heavy as water.)

7. How high is this in feet? (One foot equals three hundred and five millimeters.)

8. What pressure is this in pounds per square inch? (Two and three-tenths feet of water column press one pound per square inch.)

9. At each beat a man's heart forces eight cubic inches of blood into the arteries against a pressure of two and one-half pounds per square inch. How much work in foot-pounds is done by this man's heart at each beat? (Eight-twelfths of a foot times two and one-half pounds.)

10. At the rate of sixty beats per minute, how many foot-pounds of work is done by this man's heart in twenty-four hours?

11. How many feet vertically would the work of question 10 lift a man of one hundred and fifty pounds weight? A man could accomplish this work by two hours of steady mountain climbing. The heart does about one-fourth as much work as all other muscles combined.

NOTE: A common method of detecting the return of the pulse when the pressure is gradually released from the bag is by means of a stethoscope placed on the artery above the elbow. This requires a quiet room for accurate results. Another method is by noting the return of the pulse felt at the wrist in the usual way.

The technical name for the blood pressure apparatus is sphygmomanometer. In place of the U-tube and the mercury column a small dial-pressure-gauge is frequently used. In this type of instruments the changes in pressure produce changes upon a sensitive metal diaphragm which in turn operates the indicator on the dial.

## 38. THE CAMERA — A

**Preliminary work:** To study lens images as related to the operation of a camera.

**MATERIALS.**  $4 \times 5$  focusing camera with rapid rectilinear lens and plate-holder; pinhole camera; simple lens; cardboard screen; pinhole cardboard. (Part of the apparatus for this experiment must be obtained from the instructor.)

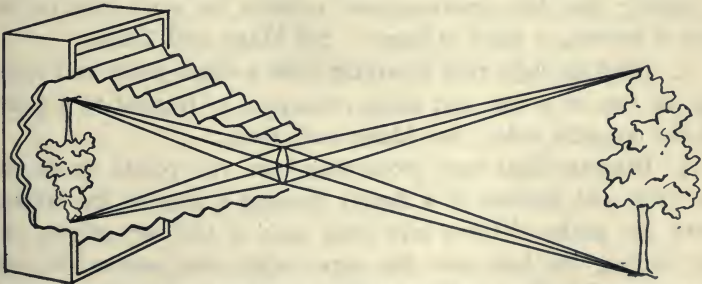
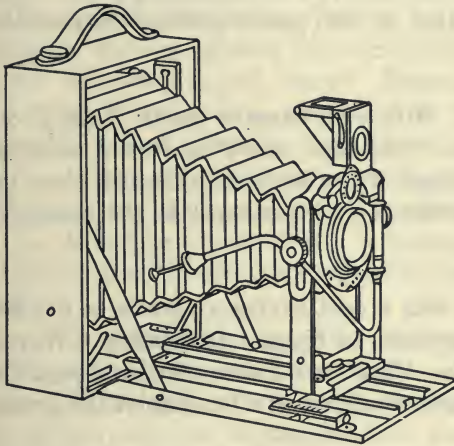

FIG. 36. — A focusing camera.

The camera, like the human eye, and the projection lantern, requires three essential conditions for its operation, — an illuminated object, a lens, and a screen. An illuminated object, for example, a flame or a house, consists of an infinite number of points, each of which is a source of light radiation. When a lens is placed between an illuminated object and a screen, an image of the object may be produced upon the screen. Each point on the object sends some of its light against the whole face of the lens. The lens converges (focuses) this light to a corresponding point on the screen. An infinite number of such points produce the complete image of the object.

**Simple Lens Images.** With a gas flame or candle flame as object, place a lens between the flame and a cardboard screen in such position that an image of the flame is projected upon the screen. The lens and screen may be fastened to the clamps of two ring stands.

1. Replace the lens with a card having a pinhole in it. Explain how a pinhole produces an image. Diagram it. Why is the image inverted? See Mann and Twiss. Look through the pinhole camera and observe the image of a building on the ground glass.

2. Diagram a lens focusing parallel light rays. Show how a reading glass lens (convex lens) refracts the sun's rays in the case of burning a piece of paper. See Mann and Twiss.

3. Diagram light rays diverging from a single point and striking the face of a lens and being converged or focused to a point on the opposite side. See Mann and Twiss.

4. Diagram light rays proceeding from two points on an object (top and bottom of a flame) through a lens to the screen. Draw the paths of three rays from each of the two points, one ray striking the lens near the upper edge, one passing through the center of the lens and one striking the lens near the lower edge.

5. Place the object (flame), lens, and screen in such positions that the image of the flame on the screen is equal in size to the object. When the object is the same in size as the image, how does the distance between the lens and object compare with the distance between the lens and image? Diagram the situation.

6. Can an image be made if only the central region of the lens is used? Place a card over the lens with a hole about a quarter of an inch in diameter. How does this affect the image?

7. Place the object, lens, and screen in such positions that the object appears three times as large as the image. In this case how does the distance between lens and object compare with the distance between lens and image? Diagram this situation.

8. If the object is moved closer to the lens, how must the screen be moved to make a sharp image?

9. If both object and screen are moved farther away from the lens, how may the lens be moved to obtain a sharp image?

10. In taking a picture with a focusing camera, which one of the three parts is ordinarily moved in focusing, — object, lens, or screen?

11. In taking a picture with a camera, what must be done to obtain a larger image on the screen?

12. In taking a picture with a focusing camera, if the object is moved closer to the camera, how should the lens be moved to make the focus sharp?

39. ELECTRIC MOTOR—A

**Preliminary work:** To study the construction and operation of an electric motor.

**MATERIALS.** St. Louis motor; two dry cells; No. 24 wire; thirty-five ampere battery ammeter.

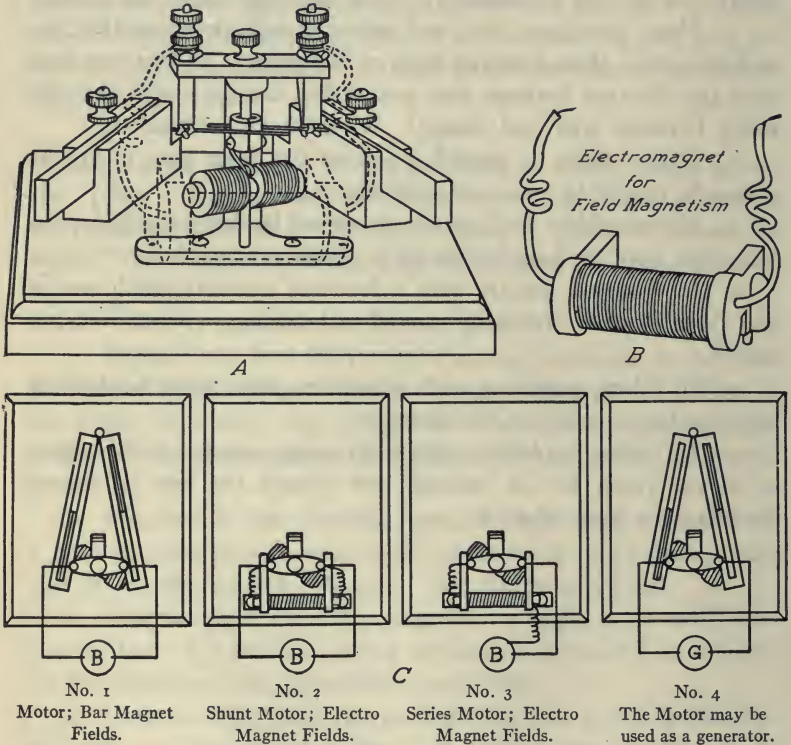

FIG. 37. — A simple electric motor.

One form of simple electric motor consists of two electromagnets — one stationary and the other so arranged that it revolves in

the magnetic field of the stationary coil. A device known as a commutator reverses the direction of flow through the revolving coil each half turn. The principal parts of a motor are: field magnet, field coil, armature (revolving coil), commutator, and brushes.

**A. Motor Operated with Permanent Field Magnet.** Remove the field coil attachment from the base board and lay it aside. Using the two permanent bar magnets for the field magnetism attach wires from one dry cell to the upper binding posts, causing the armature to rotate.

1. Name two of the essential parts of the motor through which the current passes before it reaches the armature coil.
2. What causes the armature coil to become magnetized?
3. When the current is reversed through an electromagnet what happens to its poles?
4. For what part of a revolution does the current flow in one direction through this armature coil?
5. How many times during each revolution are the poles of this armature reversed?
6. State the law which applies to the attraction and repulsion of magnetic poles.
7. What should happen with regard to the direction of current flow when the south pole of the armature comes nearest to the north pole of the field?
8. What effect upon the direction of rotation of this motor is caused by reversing the field poles?
9. Reverse the battery wires at the brush posts of the motor. What effect has this upon the direction of rotation?
10. What effect upon the speed of the armature is produced by turning the brush frame out of its normal position?
11. If the field poles are both north or both south (like poles), how does this affect the rotation of the armature?

**B. Motor Operated with Electromagnet for its Field.** Push the permanent bar magnets aside and place the electromagnet coil in position to furnish the field magnetism. Connect wires so that current from two dry cells passes first through the armature coil and then through the field coil and back to the dry cells. This represents a series wound motor.

12. Diagram a series wound motor. Observe the illustrations and refer to text on wiring of motors or generators.

13. Connect a battery ammeter and measure the current which the pressure of two dry cells sends through the motor.

14. Two dry cells in series have approximately three volts pressure. What is the resistance of this motor in ohms? While measuring the current for resistance do not let the armature rotate. Hold it. Apply Ohm's Law (Volts divided by ohms equal amperes).

15. This motor would be ruined if attached directly to the 110-volt lines. With its resistance known, calculate by Ohm's Law how many amperes would pass through it if it were attached to the 110-volt line.

16. Operate this motor with shunt wiring. Inquire of the instructor. Diagram a motor wired in shunt. See Black and Davis. Use diagram for shunt generator, omitting lamps.



## 40. THE FIRELESS COOKER: INSULATORS

To determine the quantity of heat that will escape in a given time from a fireless cooker, a thermos bottle, and an open vessel.

**MATERIALS.** Fireless cooker (commercial type); gas burner; 4-quart aluminum saucepan; thermos bottle; copper quart measure; 200 c.c. graduate; Fahrenheit thermometer; tin funnel.

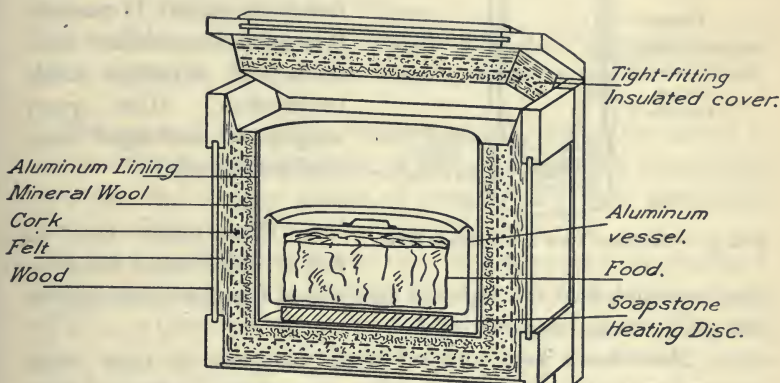
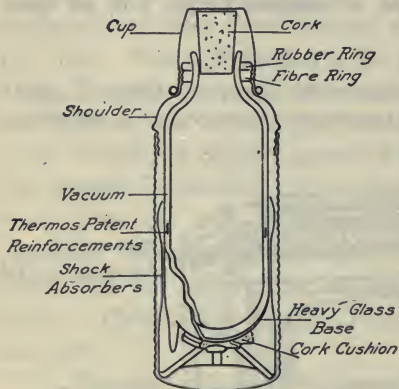

FIG. 38.— Sectional view of a fireless cooker.

**A. Fireless Cooker.** Measure carefully three quarts of water and heat it in the cooker vessel until the temperature reaches  $200^{\circ}$  F. Inclose this vessel in the fireless cooker, noting the time. Allow it to remain in the cooker for thirty minutes. Open and again note the temperature.

**B. Open Vessel.** Measure carefully three quarts of water and heat it in an open vessel (saucepan) until the temperature reaches  $200^{\circ}$  F. Remove the vessel from the stove and place it on an asbestos mat, noting the time. Allow it to cool for thirty minutes and again note the temperature.

C. **The Thermos Bottle.** Fill the thermos bottle with water heated to  $200^{\circ}$  F. Use a funnel. Insert the stopper and note the time. At the end of thirty minutes note the temperature and pour



the water from the thermos bottle into some other vessel and allow it to cool. Then pour it into a glass graduate in order to find its volume in cubic centimeters. Calculate its weight in pounds. (One pound equals four hundred and fifty-four cubic centimeters.) (One quart weighs two and eight hundredths pounds.)

FIG. 39. — Sectional view of a thermos bottle.

1. How much heat in B.T.U. above room temperature was added to the water of each vessel (pounds times degrees rise above room temperature)?

2. How much heat escaped from the water in each vessel during the thirty minutes of cooling (pounds times degrees drop from two hundred)?

3. In the case of each vessel what per cent of the heat added above room temperature was retained after thirty minutes of cooling?

4. Does a vessel filled with hot water lose heat at a more rapid rate than one filled with warm water? Explain.

5. When the water in a vessel cools explain how the cooling may involve conduction, convection, and radiation. Define each. Refer to texts.

6. If the room were very cold how would this affect the rate of cooling? Explain.

7. Make a sectional diagram showing the structure of the walls

of a fireless cooker. See texts by Butler or Lynde or Carhart and Chute.

8. Name some materials that might be used in the construction of the walls of a fireless cooker.

9. Suggest three advantages of the fireless cooker in the cooking of meats and vegetables. Has it any disadvantages?

10. In the thermos bottle, (a) what useful purpose does the vacuum serve? (b) What useful purpose does the mirrored surface serve? (c) Why does a thermos bottle have two mirrored surfaces? See Carhart and Chute.

11. With respect to heat transfer how does a refrigerator or ice box differ in its operation from a fireless cooker?

The common commercial forms of fireless cookers are simpler in construction than that shown in the accompanying illustration. As a rule the cheaper grades of cookers have very inexpensive packing of felt, paper or other insulating material.

A home-made fireless cooker may be constructed by placing a galvanized iron pail in a wooden box and packing around it, on all sides, a three-inch layer of excelsior, straw or paper. This will serve as a more efficient insulator of heat than the ordinary commercial forms of cookers.

## 41. THE GAS STOVE BURNER

## Heating Water — Cost and Efficiency.

To determine the cost of heating a quart of water from  $75^{\circ}$  F. to the boiling point,  $212^{\circ}$ , using, as fuel, illuminating gas.

MATERIALS. Gas burner; gas meter; screw clamp; clock; copper quart measure; four-quart saucepan; Fahrenheit thermometer.

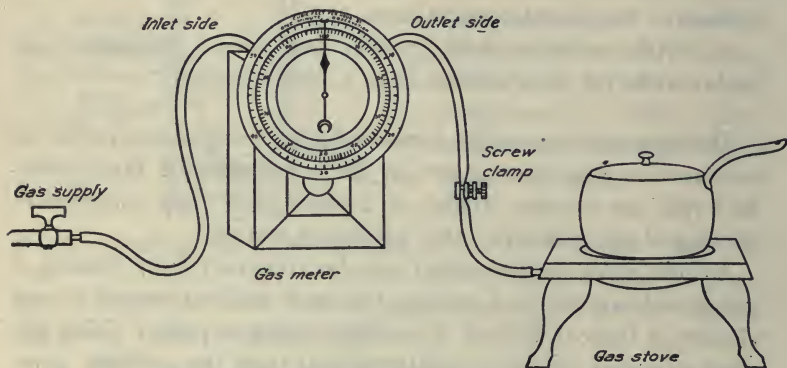

FIG. 40. — Connections for measuring the amount of gas required to heat water.

**A. Heating by Gas Burner.** Connect a piece of rubber tubing from the gas-cock to the side of the gas meter marked "inlet." Attach the burner to the other side of the meter. (*Caution. Allow a quarter of a cubic foot of gas to flow through this meter before lighting it.*) Place a screw clamp on the tube between the meter and the burner. Adjust the clamp by opening and closing so that exactly one cubic foot of gas flows through the meter in four minutes as indicated by the second hand of the clock.

Measure carefully one quart of water and heat it in a four-quart saucepan to  $75^{\circ}$  F. Stir to insure a uniform temperature. When the temperature of the water reaches  $75^{\circ}$  F., record the reading of the gas meter. Place a cover on the vessel and allow the heating

to continue till the water begins to boil as indicated by a rapid evolution of steam bubbles (not air bubbles) from the bottom of the vessel. Readjust the screw clamp each minute to keep the meter hand in proper step with the second hand of the clock. Take a careful record of the amount of gas consumed in the heating operation.

1. How many cubic feet of gas were consumed in the heating?
2. Calculate the cost at one dollar per thousand cubic feet.
3. How many B.T.U. did the water receive (pounds of water times degrees rise)? One quart weighs two and eight hundredths pounds.
4. How much heat was generated by the amount of gas consumed (one cubic foot gives out six hundred B.T.U.)?
5. What per cent of the total heat generated by the burning of the gas entered the water in the vessel? This result represents the heating efficiency of the operation.

**B. Repeat the test without a cover on the vessel.**

6. What is the cost of heating with cover removed?
7. What is the efficiency with cover removed?
8. Make a table including the results of *A* and *B* with columns showing gas consumed, cost, and efficiency.

**C. The Gas Burner.** This device is a form of Bunsen burner.

9. Hold your hand over the air inlet and cause the flame to become yellow. Explain.
10. If the air inlet is too large what happens to the flame? Some burners have an adjustable slide for controlling the mixture.
11. If the flame is turned too high under a vessel of cold water a poisonous gas is sometimes given off. Explain. See ~~Hodgdon~~.
12. Explain the fact that less gas is required to heat water if the vessel is covered.
13. List at least three ways in which gas is often burned unnecessarily in the kitchen.

## 42. GASOLINE ENGINE — A

To operate a gas engine and explain its action

**MATERIALS.** Gas engine; ignition-bottle; large glass jar; rubber tube; induction coil; four dry cells; telephone magneto with small lamp.

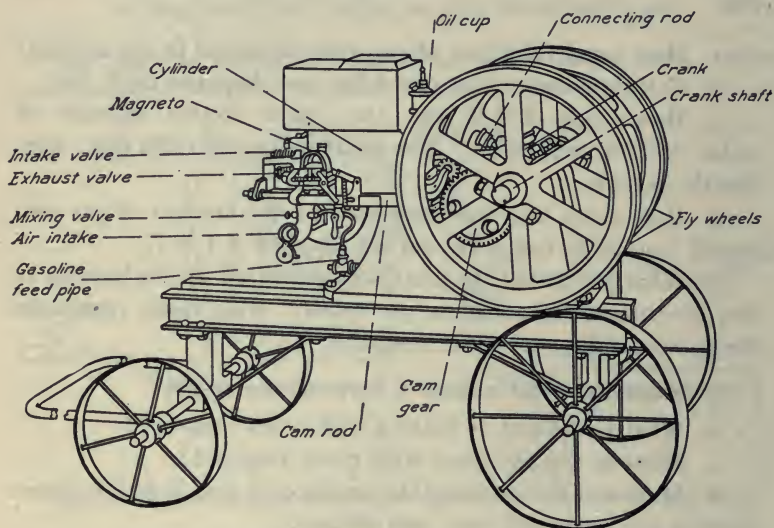

FIG. 41. — A gasoline or gas engine.

**A. The Explosive Mixture.** Fill the ignition-bottle with water and invert in the glass jar of water. Attach the rubber tube to a gas cock. Collect a half bottle of gas by displacement over water. Remove the bottle allowing air to enter forming a mixture of half gas and half air. Hold your hand over the end of the bottle and invert a few times to mix the air and gas. Remove your hand and bring a lighted match to the mouth of the bottle. Does the mixture burn?

1. Does a bottle of pure illuminating gas burn more or less readily than half air and half gas?

2. Vary the proportions of the mixture and determine from the report of the explosion approximately what proportions by volume of air and gas give the most effective explosion. Which gives the better explosive mixture, one-fourth gas or one-fifth gas?

3. What is meant by the statements that the mixture in an engine is "too rich" or "too lean"?

**B. Ignition.** The magneto and the induction coil. The explosion in gas engines is caused by a spark from a magneto (electric generator) or from an induction coil operated by dry cells. Operate a magneto generator, causing it to light a small lamp. (*Caution. An induction coil is dangerous. Do not touch the secondary terminals after attaching the battery to the primary.*) Attach a wire from one terminal of the secondary coil to within a quarter inch of the other. This will form the spark-gap. Connect one terminal of the battery of four dry cells to one terminal of the primary. Touch the other battery terminal to the primary terminal of the coil. The vibrator changes a continuous battery current to an intermittent current. An intermittent current in the primary causes a very high voltage current to be induced in the secondary. This high voltage current produces the spark for the ignition. (*Caution. To avoid the possibility of an accidental shock from the secondary terminals always disconnect the dry cells from an induction coil while working with the secondary circuit.*) Attach wires from the secondary terminals to a spark plug and operate it. Mount the spark plug in a ring-stand clamp.

4. Diagram the apparatus showing induction coil, four dry cells, and spark plug with proper wiring. See Experiment 91.

The type of induction coil used in operating a gas engine is commonly a simple spark coil. It consists of a simple coil of many turns of wire with a soft iron core at the center. This small type of coil gives a hot spark when the contact is broken. The igniter mechanism on the side of the cylinder operates the "make

and break" furnishing a hot spark inside at the proper time. This is called a "make and break" system of ignition. When a spark plug is used as in an automobile it is known as a "jump spark" system. The vibrator type of induction coil furnishes a jump spark. The electric current for ignition may be produced by a magneto generator which is operated by the engine. As a source of ignition current the magneto is preferable to dry cells since dry cells will soon run down and require replacing.

**C. The Engine.** Before starting fill the cylinder hopper with water. Oil the cylinder and bearings. This engine may be operated with illuminating gas instead of gasoline. The air and illuminating gas are mixed at the mixing valve. Ask the instructor to start the engine. Keep a safe distance from moving wheels. Observe its operation. Locate the following parts, — mixing-valve, cylinder, piston, intake valve, exhaust valve, crankshaft, cam, and cam rod.

5. Make four diagrams representing the four strokes (half revolutions of a four-stroke engine). See Millikan, Gale and Pyle or Black and Davis.

6. What causes the mixture to enter the cylinder?

7. What adjustment must be made at the mixing-valve to get effective working conditions?



## 43. HEATING A ROOM — COST — A

To determine the cost of heating an average room by (a) gas stove, (b) basement furnace, (c) electric heater.

On a cold day a room of average construction, exposure, and ventilation will require approximately five thousand B.T.U. per hour for each thousand cubic feet of room space. A room  $10 \times 15 \times 10$  feet high contains fifteen hundred cubic feet. It will therefore require seven thousand five hundred B.T.U. per hour.

Determine the cost of heating this room per hour by each of the following methods:

**A. Heating by Gas Stove (without flue).**

1. One cubic foot of gas supplies six hundred B.T.U. How many cubic feet of gas will be required to heat this room per hour?
2. What will be the cost per hour at one dollar per thousand cubic feet?

**B. Heating with a Basement Furnace (steam, hot-water, or hot-air).**

3. One pound of coal of average quality furnishes thirteen thousand B.T.U. when burned in a furnace or stove. How many pounds of coal will be required to heat this room per hour if only sixty per cent of the furnace heat reaches the radiators?

4. What becomes of the other forty per cent of the heat of the coal?

5. What will be the cost per hour at ten dollars per ton?

6. Calculate the amount of coal required to heat six rooms for one cold day of twenty-four hours if for eight hours during the night only one-third heat is required.

7. Calculate the amount of coal required for the heating period of two hundred days if the average heat for each of the two hundred days is three-sevenths of that required for a cold day.

**C. Heating with an Electric Heater.**

8. One kilowatt-hour generates three thousand four hundred B.T.U. How many kilowatt-hours of energy will be required to heat this room for one hour?

9. What will be the cost per hour at eight cents per kilowatt-hour?

10. Is any heat lost in the case of the electric current?

**D. Summary.** As a summary arrange the results of the three calculations in a table with columns showing the following data: (a) cost of heating a six-room house per hour; (b) cost of heating a six-room house per day, considering that for eight hours during the night only one-third as much heat is required as during the day; (c) cost of heating a six-room house for a year, considering that the average heat for two hundred days' heating is three-sevenths of that required for two hundred cold days.

**E. Reference Work: *General Science*, Barber.**

11. List the heat value per pound of the following: carbon, hydrogen, oak wood, pine wood, bituminous coal, anthracite coal, petroleum.

12. What was a Roman hypocaust?

13. Contrast advantages of steam and hot-water heating systems.

14. Diagram a ball and lever safety valve.

15. As the pressure rises in a steam boiler what is the effect upon the boiling point?

## 44. HEATING A ROOM — COST — B

To determine the cost of heating an average room by (a) coal stove, (b) wood stove, (c) open fireplace.

On a cold day a room of average construction, exposure, and ventilation will require approximately five thousand B.T.U. per hour for each thousand cubic feet of room space. A room  $10 \times 15 \times 10$  contains fifteen hundred cubic feet. It will therefore require seven thousand five hundred B.T.U. per hour.

Determine the cost of heating this room per hour by each of the following methods :

A. Heating with a Coal Stove.

1. One pound of coal of average quality furnishes thirteen thousand B.T.U. when burned in a stove. How many pounds of coal will be required to heat this room per hour if seventy per cent of the heat reaches the room?

2. What will be the cost of heating the room for one hour at ten dollars per ton?

Stoves provide one of the most economical means of heating because they are located in the room and usually not many rooms are supplied. Houses are often heated in this way and may require only three to five tons of coal for the entire winter, while an average house with a steam or hot-water furnace may require fifteen to twenty-five tons.

3. Explain why a stove in a room furnishes a higher percentage of the heat to the room than a furnace in the basement?

4. Calculate the amount of coal required to heat two rooms for one cold day of twenty-four hours if for eight hours during the night only one-third heat is required.

5. Calculate the amount of coal required to heat two rooms for the heating season of two hundred days if the average heat is three-sevenths of that required for cold days.

**B. Heating with a Wood Stove.**

6. A pound of dry wood generates eight thousand B.T.U. If a wood stove is seventy-five per cent efficient how many pounds of wood will be required to heat this room for one hour?

7. What will be the cost per hour at eight dollars per cord? A cord of wood weighs two tons.

8. At these rates how does heat from a wood stove compare in price with heat from a coal stove?

9. Mention advantages and disadvantages of wood stoves and coal stoves aside from cost of fuel.

**C. Heating by Open Fireplace.**

10. An open fireplace is about thirty per cent efficient. Using data under *B* how many pounds of wood would be required to heat the room for one hour?

11. What would be the cost per hour?

12. Which one of the three methods of heat transfer is involved chiefly in the operation of a fireplace? Refer to texts.

**D. Summary.** Make a summary of the results of the three calculations in the form of a table with columns showing the following data: (*a*) cost of heating a six-room house per hour; (*b*) cost of heating a six-room house per day, considering that for eight hours during the night only one-third as much heat is required as during the day; (*c*) cost of heating a six-room house for a year, considering that the average heat for two hundred days' heating is three-sevenths of that required for two hundred cold days.

## 45. HOUSE GAS SUPPLY — CITY GAS

To study the operation of household gas appliances.

**MATERIALS.** Gas meter; rubber tubing; laboratory Bunsen burner; gas stove burner; gas iron; open flame gas lamp.

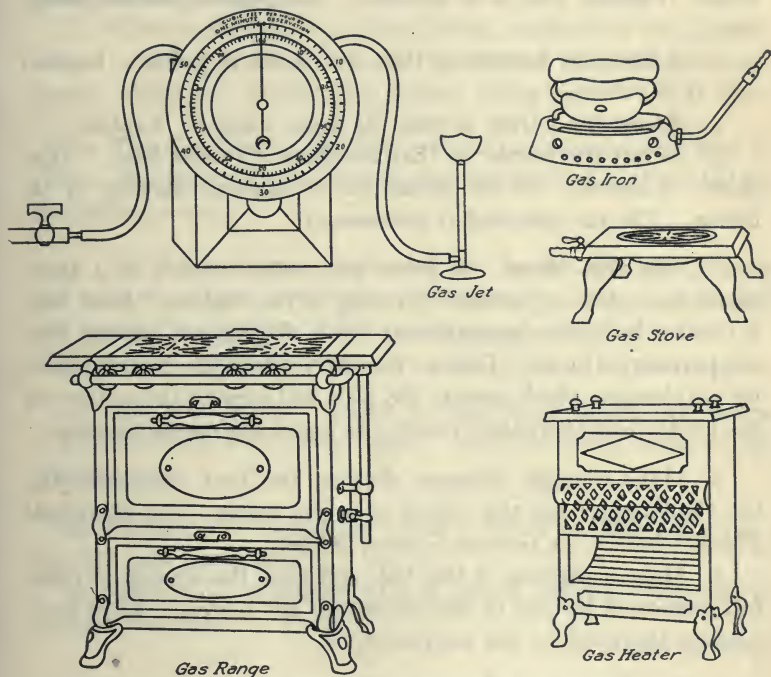

FIG. 42. — Typical gas appliances.

**A. Attaching a Gas Meter.** Connect a tube from a gas cock to the inlet side of the meter. To the outlet side of the meter attach a laboratory Bunsen burner. (*Caution.* Allow a quarter of a cubic foot of gas to flow through the meter before lighting it.) Note that the Bunsen burner is a device for permitting air to mix with

the gas before the gas reaches the flame. It is provided with adjustments which vary the proportion of gas and air.

1. Diagram a Bunsen burner and briefly explain its construction. See *General Science*, Hodgdon.

2. Adjust the burner so that it gives a colorless or bluish flame. Explain why it is colorless. See *General Science*, Hodgdon.

3. Adjust the burner so that the flame is yellow. Explain why it is yellow.

4. Adjust the burner so that the flame smokes. Explain.

5. Adjust the burner so that the flame "strikes back." Explain. (*Caution. Do not permit gas to continue burning at the bottom. The gas generated is poisonous.*)

**B. The Gas Meter.** A house gas meter consists of a sheet metal box with a partition dividing it into halves. Each half is divided into two compartments by a diaphragm, making four compartments in all. Gas, in flowing through the meter, moves the diaphragms which operate the dials and register the amount of gas used. Gas alternately enters and leaves the compartments.

6. Make a simple diagram showing the four compartments, the diaphragms; and the valves of a gas meter. See *Household Physics*, Butler; or *General Science*, Barber.

7. Make a diagram of the dials and state the reading in cubic feet registered by one of the laboratory gas meters. Have your reading approved by the instructor.

**C. Gas Stoves and Ranges.** The gas stove is a modification of the Bunsen burner. Stove burners are often equipped with an adjustable air vent.

8. Hold your hand over the air inlet of the stove burner. Explain the effect upon the flame.

9. Diagram a star-shaped range burner showing adjustable

air vent. What is the reason for this shape? See *Mechanics of the Household*, Keene.

10. What are the two common types of burners on gas stoves? See *General Science*, Hodgdon.

11. State the main points in adjusting a gas burner. See *General Science*, Hodgdon.

12. When a gas burner is opened wide, especially if the flame is cooled by a kettle of cold water, it sometimes gives off poisonous fumes. Explain. See *General Science*, Hodgdon.

**D. The Gas Iron.** Attach a gas iron to the meter and heat it. Adjust the flame till you consider that enough heat is generated for continuous ironing.

13. Let the gas flow at the ironing rate for ten minutes and note the amount of gas consumed. Calculate the cost of operating the iron per hour at one dollar per thousand cubic feet.

An electric iron costs about five cents per hour for current.

**E. The Gas Lamp.** Attach an open flame burner by means of a rubber tube with screw clamp. With the screw clamp adjust the burner.

14. Operate the open flame burner for ten minutes and calculate the cost per hour.

15. Explain the operation of a Welsbach mantle. See *General Science*, Hodgdon.

## 46. HOUSE WATER SUPPLY

To attach a supply pipe including stopcock, meter, and faucet to the water line and study their operation.

**MATERIALS.** Piping; stopcock; water meter; two feet of flexible hose; screw faucet; compression-faucet; faucet washers; hose washers; fixtures; gallon measure; wrench; screw driver.

**A. Testing the Meter.** (*Caution. Do not attach this meter to a hot-water faucet as one of the moving parts is made of hard rubber*

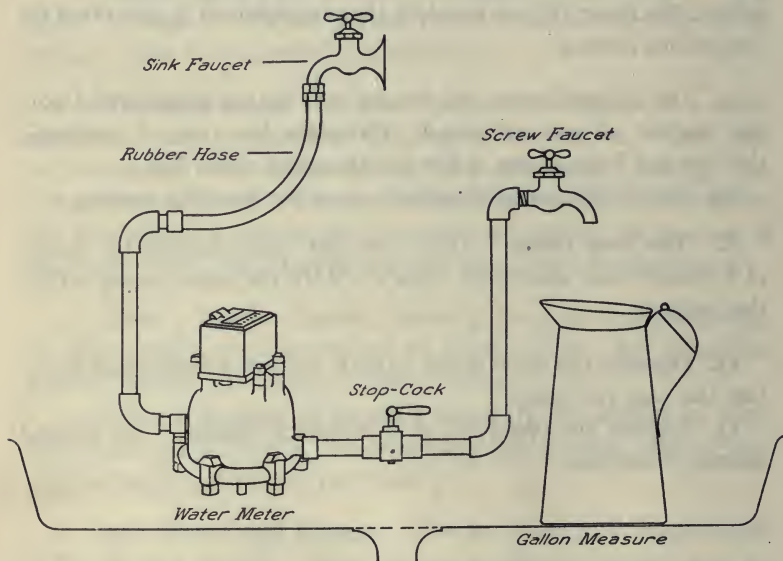

FIG. 43.—Apparatus for the study of house water supply.

*which would be injured by hot water.*) Attach the meter with piping, stopcock, and faucet to the laboratory faucet by means of the flexible rubber hose. Note.—Place hose washers in the ends of the flexible hose to prevent leakage. When attachments are all



made tight allow water to flow through noting that the indicator on meter dial registers the number of cubic feet of water used.

1. With the gallon and quart measures determine carefully how many quarts of water flow through while the meter registers one cubic foot. (Two hundred and thirty-one cubic inches equal one gallon.) How does the dial reading compare with your actual measurement?

2. What is the purpose of the stopcock on the house water supply line?

3. If for any reason the water pipes in the house burst, what would you do in the emergency to prevent a flood?

4. Why is it necessary to lay water pipes deeper in the ground than gas pipes?

5. Make a sketch of the dials of a water meter and state the reading. See *General Science*, Hodgdon. For sectional view of water meter see Hodgdon, and *General Science*, Barber.

**B. Faucets — Operation and Repair.** Shut the water off at the stop-cock. Open the faucet with a wrench by unscrewing the top. Remove the screw and note that there are two washers to prevent leakage, one at the top of the screw and one at the bottom.

6. Diagram a screw faucet. See Butler's *Household Physics*.

7. Diagram a compression faucet.

8. In the screw faucet when does the lower washer function? When does the upper one function?

9. If a screw faucet leaks when it is turned off how might this trouble be remedied?

10. If a screw faucet leaks at the handle when it is turned on, how might this trouble be remedied?

**C. Closet Tanks.** The closet tank serves as a reservoir for flushing the closet. The amount of water is controlled by an automatic float valve which rises when the tank gets full and shuts off the in-flowing water. It also provides for an outlet attachment

which remains open till the tank is completely emptied and then closes automatically.

11. Diagram the old form of closet tank. See Butler.
12. Diagram two common types of closet tanks in use at the present time. See *General Science*, Hodgdon.
13. Explain the action of the siphon type of tank.

#### 47. THE DEW POINT

**To determine the dew point (temperature) of the air in the laboratory at a particular time.**

**MATERIALS.** Polished nickel-plated beaker, capacity about five hundred c.c.; Fahrenheit thermometer; ice; pan for ice.

**A. Water Vapor in the Air.** Water from rivers, lakes, the ocean, etc., is continually evaporating into the air. When the air gets filled with moisture and is chilled by a cold wind in the upper atmosphere, fogs form into clouds and drops of water fall down as rain. Air takes up moisture in the same way that water dissolves certain salts. It is very important to note the fact that warm air can hold (dissolve) many times as much water as cold air. When saturated air is chilled it may result in a fog. If the earth cools at night and chills the air it may result in the formation of dew. If saturated air in the upper atmosphere is chilled by a cold air current it may result in clouds (fog), snow, or rain. The temperature at which any given air begins to give out moisture is called the dew point for that particular air. The dew point of the air in the laboratory may be found by placing water in a metal cup and gradually cooling it. The cold cup then chills the air surrounding it and dew begins to form on the outside of the cup.

**B. Determination of the Dew Point of the Air in the Room.** Place in the cup two hundred cubic centimeters of water at about the temperature of the room. Stand the thermometer in the water

and slowly cool it by dropping in pieces of ice about the size of a nickel. Cool the water carefully at the rate of four degrees per minute. Stir the ice and water constantly in order to get a correct result. Observe the polished surface of the cup for the first appearance of moisture as indicated by your finger leaving a path when rubbed over the cup. Do not breathe against the cold cup. When the first dew is noticed read the temperature of the thermometer in the water. (If the indoor air is very dry, as it often is in winter, it may be necessary to add salt to the ice.) This temperature should be the approximate dew point. It is too low because you really cooled the water a few degrees below the dew point before the dew was observed. Make at least three determinations and see if they agree. Correct your result by adding two degrees since you did not actually see the moisture till after it first appeared. Test the correctness of this result. If moisture continues to form raise the temperature two degrees above it by adding a little hot water and see if the moisture disappears. A preferable method is as follows: When the first dew is observed take the temperature. Then heat the water at the same rate as it was cooled, by adding small quantities of hot water, and note the temperature at which the dew disappears. The dew point should be the average of these two temperatures.

1. With respect to dew point explain what causes drops of water to form on a pitcher and frost to form on the window pane.
2. What makes one's breath visible on a cold day?
3. What is meant by a good drying day for laundry purposes?
4. How does the air in a refrigerator lose its moisture? See *General Science*, Barber.
5. Explain the formation of clouds and fogs. See *Weather*, Jameson, or *General Science*, Barber.
6. Explain the formation of rain and snow.

## 48. THE JACK-SCREW

MATERIALS. Jack-screw; two 50-lb. iron weights; yardstick; small spring balance.

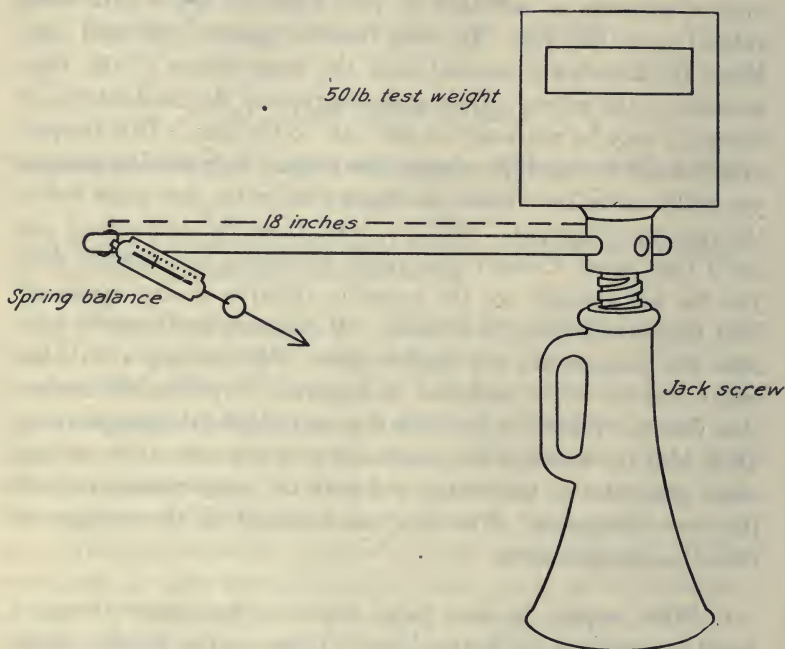

FIG. 44. — Lifting a fifty-pound weight by means of a jack-screw.

Jack-screws are often used in lifting a building from its foundation. A comparatively small force exerted through a long distance in turning the handle exerts an enormous upward force through a small distance. In one revolution of the jack-screw the screw is lifted the distance between two threads of the screw.

**A. Operating a Jack Screw.** Put a fifty-pound weight on the top of the jack-screw. Place the iron rod in the opening. At a

point eighteen inches from the center of the jack-screw pull the handle with a small spring balance.

1. How far in feet does a point on the handle eighteen inches from the center of the screw move in lifting the screw the distance between two threads (circumference of the circle)?

2. What is the amount of this force in pounds, in lifting fifty pounds?

3. What is the "work in" in foot pounds done per revolution (pounds times circumference)?

4. If the distance between two threads is five-sixteenths of an inch, what is the "work out" in foot pounds done per revolution?

5. What is the efficiency ("work out" divided by "work in")?

6. In the operation of the jack-screw what causes the "work out" to be so much less than the "work in"?

7. Suggest a means of increasing the efficiency of this device.

8. When work or energy seems to disappear as a result of friction into what is it usually transformed?

**B. Efficiency with Two Fifty-Pound Weights.** With the instructor's assistance place two fifty-pound weights on the jack-screw, one above the other. Place them in position very carefully so that they do not fall off. Handle cautiously to avoid injury and remove the weights as soon as the measurements are made.

9. Determine the efficiency in lifting one hundred pounds.

10. A screw is a modification of an inclined plane. See Hoadley. The slope of a hill is one thousand feet in length. If the hill is fifty feet in altitude (vertical distance between the levels of the top and bottom) how much work is done when a one-ton wagon is raised a vertical distance of fifty feet? If in doing this a horse pulls the wagon with a force of one hundred and twenty pounds along the slope (one thousand feet) what is the "work in"?

11. Calculate the efficiency in problem 10.

12. What are some of the causes tending to reduce the efficiency below one hundred per cent in problem 10?

## 49. THE KEROSENE STOVE

## Heating Water — Cost and Efficiency.

To determine the cost of heating a quart of water from  $75^{\circ}$  F. to the boiling point,  $212^{\circ}$ , using, as fuel, kerosene.

**MATERIALS.** Kerosene stove (single burner Perfection stove); can of kerosene; copper quart measure; 200 c.c. graduate for kerosene; tin funnel; tin pan, eight-inch diameter, for pouring kerosene from the stove; four-quart saucepan or kettle; Fahrenheit thermometer.

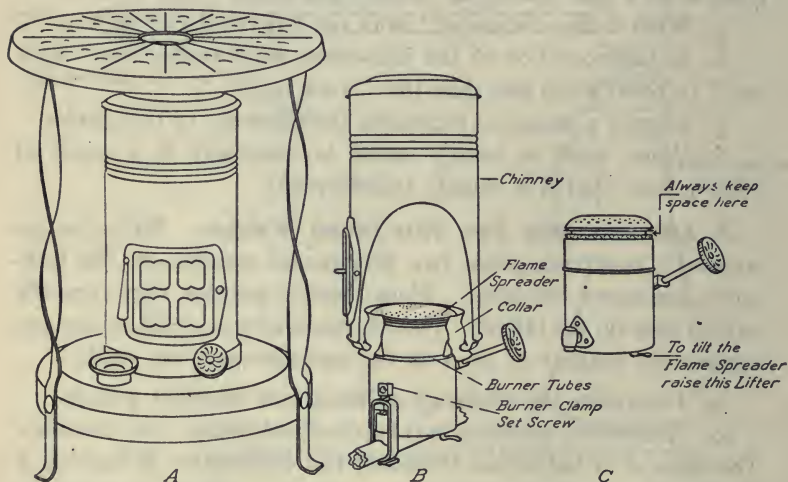

FIG. 45. — Kerosene stove, wick type, showing burner and chimney parts.

**A. Heating by Kerosene Stove.** Examine the stove tank carefully before you begin work to be sure that it is entirely empty. The instructor will give you directions in regard to emptying the tank. Using the funnel and 200 c.c. glass graduate, carefully place 300 c.c. of kerosene in the tank of the stove. (*Caution. Make measurements accurately and avoid spilling a single drop.*)

*Drain the graduate thoroughly when pouring into the stove. Also drain the stove thoroughly when pouring into the graduate.)* Before proceeding further with the experiment, test your ability to make these measurements by pouring the kerosene out again measuring it with the glass graduate and see if you can get out the same quantity of kerosene which you have put in. Have this procedure approved by the instructor. Again measure carefully and pour 300 c.c. of kerosene into the tank of the stove.

Measure carefully one quart of water and place it in the saucepan with cover and heat it on a gas burner to  $75^{\circ}$  F. Transfer the saucepan to the kerosene stove and light the burner. Have the stove inspected by the instructor at this point and he will advise you regarding the proper size of flame. It should be turned up so that the yellow tips of flame are visible above the blue flame. Heat the water to the boiling point ( $212^{\circ}$  F., or evolution of steam bubbles) and extinguish the flame. Carefully pour out all of the remaining kerosene and measure it in cubic centimeters. Subtract from original amount.

1. Record the number of cubic centimeters of kerosene consumed. Reduce to pounds. (Five hundred and sixty-seven c.c. of kerosene weigh one pound.)
2. Calculate the cost of the fuel consumed at fifteen cents per gallon. (One gallon equals three thousand seven hundred and eighty-five c.c.)
3. How many B.T.U. did the water receive? (Pounds of water times degrees rise. One quart of water weighs two and eight-hundredths pounds.)
4. How much heat was generated by the amount of kerosene consumed? (One pound of kerosene generates twenty thousand B.T.U.)
5. What per cent of the total heat generated by the burning of the kerosene entered the water in the vessel? This result represents the heating efficiency of the operation.

**B. The Kerosene Stove.** This stove is similar in operation to a kerosene lamp.

6. Explain how a large supply of oxygen reaches the flame.
7. What is the function of the tall chimney? Why would a shorter chimney not do as well?
8. How does making the tank of flat shape and placing the burner as low as possible, reduce smoking and odor in a wick stove?

## 50. LEVERS AND SCALES

To study levers and scales.

**MATERIALS.** Two fifty-pound iron test weights; five-foot iron crowbar (pinch point type); thirty-pound spring balance; three-sided file for fulcrum; laboratory beam balance; steelyard; platform scales; wooden box eight inches on each side.

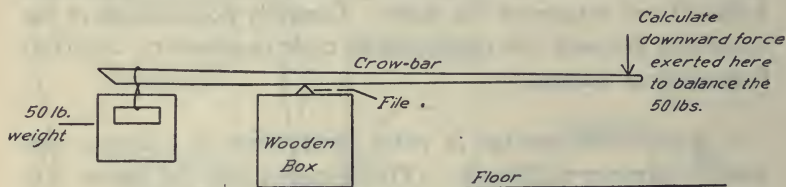

FIG. 46. — Lever with fulcrum located between the ends.

**A. The Crowbar.** Place the file on the box. With this file as a fulcrum balance the crowbar on it. Mark the point on which the bar balances with a pencil or a piece of chalk. Use this point on the bar for the fulcrum.

1. With a rope over the handle of one of the fifty-pound weights hang the weight on the bar at a point twenty inches from the fulcrum. Calculate the weight needed on the opposite end of the bar to balance the fifty-pound weight. Apply the lever law, weight times arm length on one side equals weight times arm length on the other side. (Power times power arm equals weight times weight arm.)



2. With the fifty-pound weight in the same position as before, push downward at a point on the opposite side thirty inches from the fulcrum. Calculate the force in pounds required to balance the fifty-pound weight in this case.

3. With the fifty-pound weight suspended from a point ten inches from the fulcrum, push downward on the opposite side at a point thirty inches from the fulcrum. Calculate the force required for a condition of balance in this case.

4. Make diagrams of the three types of levers. How would you characterize each? Give two examples of each type. Refer to texts.

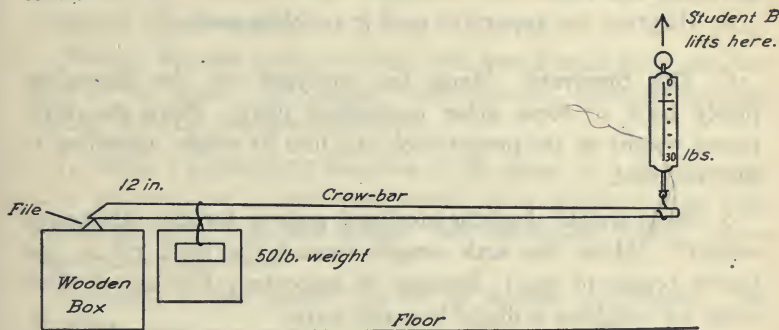

FIG. 47. — Lever with fulcrum at one end.

**B. Lever with Fulcrum at the End.** Place the sharp end of the bar on the file as a fulcrum. Let your associate hold the other end of the bar. Suspend the fifty-pound weight by means of its rope at a point twelve inches from the fulcrum.

5. Applying the lever law, calculate the lifting force required at the end of the bar to support the fifty-pound weight located twelve inches from the fulcrum. (NOTE. Measure both lever arms from the fulcrum.)

6. Hold the end of the bar with a thirty-pound spring balance. Note the reading of the balance with weight on. Then remove the weight and find how much of this downward force is caused

by the weight of the bar itself. Subtract this amount from the previous reading. How does this result compare with the calculated force in No. 5?

7. Place the file on the floor and place the sharp end of the bar on it. Let your associate stand on the bar at a point eight inches from the fulcrum. Raise the other end of the bar with the thirty-pound balance. Ask a third person to note accurately the reading on the spring balance. Deduct for the weight of the bar and calculate your associate's weight. (Place the center of the heel on the proper point of the bar when the reading is made to get a more accurate result.)

8. Diagram the apparatus used in problem seven.

**C. The Steelyard.** Hang the steelyard on the laboratory pulley hook or some other convenient place. Place the fifty-pound weight on the proper hook and find its weight according to the steelyard.

9. What weight does the steelyard register for the fifty-pound weight? (Move the scale weight toward the hook till it just barely begins to rise.) Because of inaccuracy the use of steelyards for weighing is illegal in many states.

10. Would you judge a steelyard to be more accurate on the light weight side, or on the heavy weight side? Explain. Weigh some object on the light weight side. (Change the hooks.)

**D. Balances.** Examine an equal arm balance (platform type). See Barber's *General Science*.

11. Explain the purpose of the lower mechanism of a laboratory equal arm balance of the platform type.

12. Remove the platform from the laboratory platform scales and examine the levers. Diagram the levers in a hay scales, marking all fulcrums with the letter F. See Millikan, Gale, and Pyle, or Hoadley.

## 51. THE MICROSCOPE — SIMPLE AND COMPOUND

To construct a compound microscope and study its optical principles.

**MATERIALS.** Ring stand; two adjustable clamps; small double convex lens of short focal length; reading glass lens; laboratory compound microscope. (Part of the apparatus for this experiment must be obtained from the instructor.)

**A. Lens Images.** The compound microscope and the astronomical telescope are similar in principle in that both consist essentially of two lenses. In both instruments, the object produces an image by means of the objective lens. The eye-piece then magnifies this image.

(NOTE. Handle lenses carefully and avoid scratching the surface of the glass. In making measurements, measure approximately from the center of the lens.)

1. Make a preliminary diagram of the image of a gas flame as it is produced on a cardboard screen by a simple convex lens, including object, lens, and image. See Mann and Twiss. Have this drawing approved.

2. Diagram the human eye as an optical instrument. See Hoadley.

3. Make a diagram showing how a convex lens magnifies an object. Include object, lens, eye and light rays. See Carhart and Chute, Black and Davis, Hoadley or Millikan, Gale, and Pyle.

4. Measure approximately the focal length of each lens by holding it in the path of parallel rays (rays from the sun). Focal length is the distance between the center of the lens and the point of sharp focus for parallel rays. Measure approximately from the outer edge of the lens. If you cannot get sunlight measure the distance from the lens of the image of a distant tree or pole.

**B. The Compound Microscope.** With the clamp and ring stand place the lens of short focal length one and three quarters

inches from a book on the table. The second lens should be located approximately ten inches above the first. Observe a small letter on this page through the lenses.

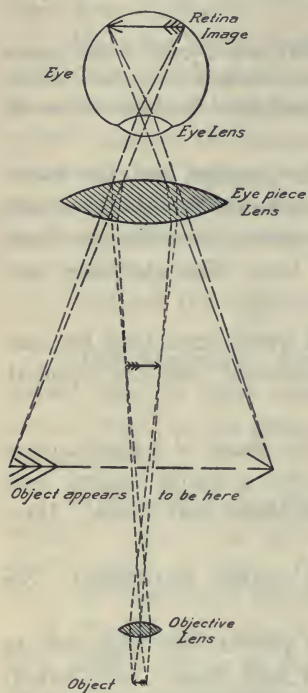

FIG. 48. — Two simple lenses used as a compound microscope.

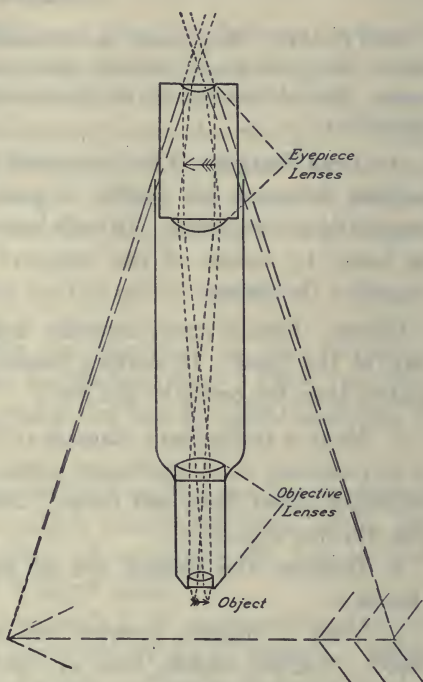

FIG. 49. — Lens arrangement in a high power microscope. See Fig. 50.

5. Is the image produced by a compound microscope erect or inverted?

6. Diagram light rays passing through the two lenses of a compound microscope, showing how the first lens produces an image and the second lens magnifies that image. Indicate by dotted lines the points from which the rays appear to come as they enter the eye.

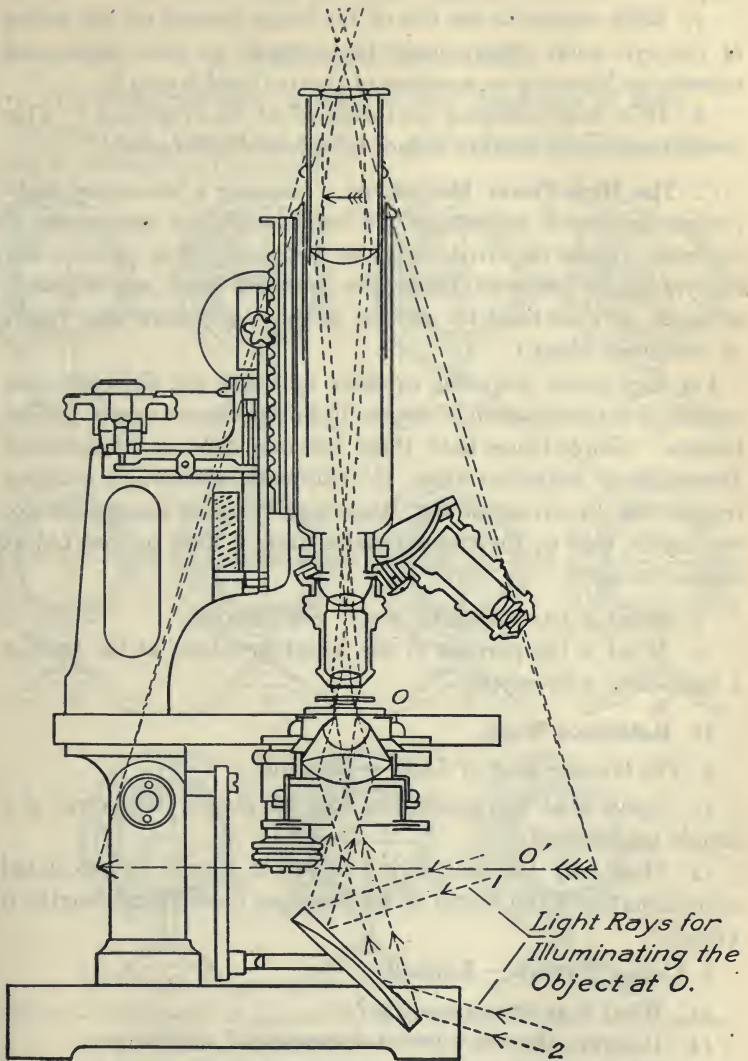

FIG. 50. — A compound microscope showing the system of lenses.

7. With respect to the size of the image formed on the retina of the eye, what effect should be produced in your improvised microscope by using an eyepiece of shorter focal length?

8. How does enlarging an image affect its brightness? This is one reason why objects cannot be enlarged indefinitely.

**C. The High-Power Microscope.** Examine a laboratory high-power compound microscope. (*Caution. Do not remove any of the lenses without the assistance of an instructor. The objective and the eyepiece are composed of expensive compound lenses, very delicately adjusted. Do not touch the surfaces of these lenses with your fingers or any other object.*)

For high-power work the eyepiece unit and the objective unit consist of a combination of lenses, to produce more nearly perfect images. Simple lenses have three common defects, (a) spherical aberration or imperfect focus, (b) chromatic aberration or color fringes due to refraction and dispersion, (c) their images are not rectilinear, that is, they do not make straight lines on the object appear straight.

9. What is an achromatic lens? See Hoadley.

10. What is the purpose of the reflecting mirror at the base of a compound microscope?

#### **D. Reference Work.**

a. *The Wonder Book of Light* — Houston.

11. Upon what two conditions does the magnifying power of a simple lens depend?

12. How may the magnifying power of a lens be calculated approximately if the length of its principal focus (focal length) is known?

b. *College Physics* — Kimball.

13. What is an immersion lens?

14. Diagram the objective of a compound microscope.

15. What focal length is common in a high-power objective?

## 52. THE OPTICAL DISK

To study reflection, refraction, and dispersion of light.

MATERIALS. Optical disk with set of attachments. (This apparatus must be obtained from the instructor.)

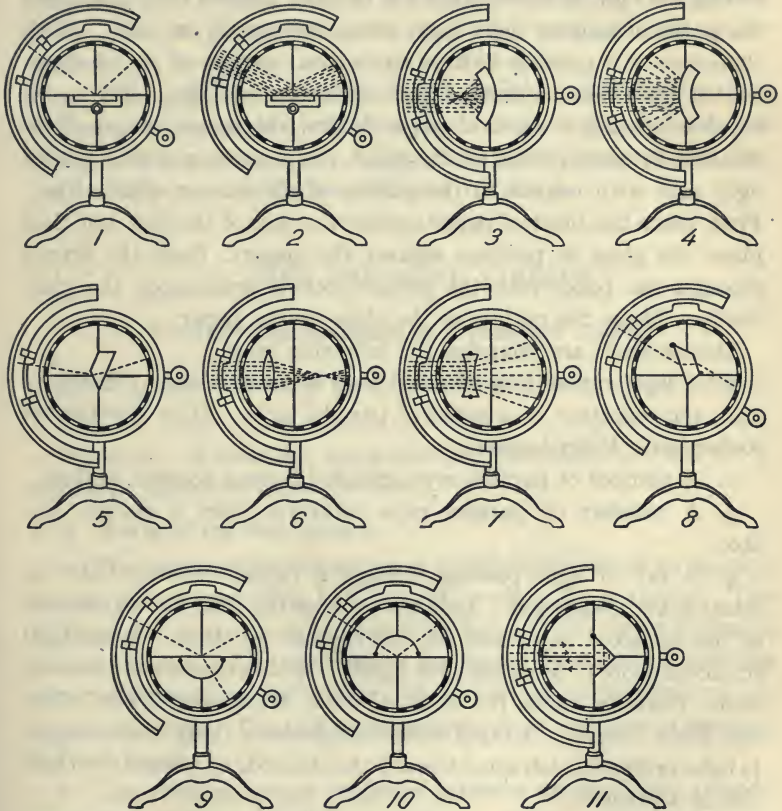

FIG. 51. — Arrangement of apparatus for demonstrating reflection, refraction, and dispersion of light.

This experiment requires sunlight. (*Caution.* Handle the glass parts of this apparatus with extreme care. The screws for

*fastening them to the disk should be provided with heavy leather or hard rubber washers. Fasten the glass parts firmly to prevent their falling off.)*

Place the optical disk in the path of the direct rays of the sun, letting the light shine through one or more narrow slots producing the paths of isolated light rays, across the face of the disk. With these rays it is possible to illustrate a great variety of the phenomena of reflection, refraction and dispersion of light. The work involves placing a sheet of paper behind the lenses, etc., and indicating by proper lines on the paper the position and direction of light rays with respect to the outline of the lens or other object. First, place the sheet of paper against the face of the disk and then place the glass in position against the paper. Push the screws through the paper into the proper sockets and fasten the glass firmly. Draw the outline of the glass on the paper.

Demonstrate and diagram the following cases:

1. A light ray as it is reflected from a plane mirror. Diagram, also, the reflection of a series of parallel rays. State the Law of Reflection. Refer to texts.

2. A number of parallel rays reflected from a concave surface.

3. A number of parallel rays reflected from a convex surface.

4. A ray of light passing through a prism, showing both refraction and dispersion. Indicate by lines the blue ray on one side of the refracted beam and the red ray on the other. Is red light refracted more or less than blue light? Which represents the more rapid vibration rates, red or blue? See Mann and Twiss, *Color and Wave Length*. A rapid vibration causes a short wave length. Is light ordinarily refracted toward the thin side or toward the thick side of a prism?

5. A series of parallel rays refracted in passing through a convex lens. Measure the focal distance of this lens. Name two conditions upon which the focal distance of a lens depends. Refer to texts.



6. A series of parallel rays refracted in passing through a concave lens.

7. A ray in passing through a thick piece of glass with parallel sides. Set the glass so that the ray strikes the surface of the glass obliquely.

8. A ray in passing through a thick piece of glass with parallel sides. Set the glass so that the ray strikes perpendicular to the surface. Is there any refraction in this case?

9. A ray striking the center of the flat side (center of curvature) of the semicircular glass with its center of curvature placed on the center of the optical disk. Adjust the angle of incidence so that part of this ray is reflected and part refracted.

### 53. THE PRESSURE COOKER

**To study the operation of a pressure cooker.**

**MATERIALS.** One-burner gas stove; pressure cooker, with thermometer attachment.

*(Caution. Handle this apparatus very carefully. Do not use a wrench to tighten or loosen the cover.)*

#### **A. Parts of the mechanism :**

a. The safety valve, consisting of a ball which covers an opening in the valve seat. This ball is held in place by a spring. The safety valve prevents the cooker from bursting in case of excessive steam pressure. The pressure of the spring is overcome and the steam escapes when the pressure rises to about twenty-five pounds per square inch. The ball must be kept clean and free to move in the valve seat.

b. The pressure gauge registers pressure up to thirty pounds per square inch.

c. This cooker has been equipped with a thermometer for observing changes in the boiling point due to increased pressure.

*d.* Note the sloping surfaces where the cover fits against the cooker. They have been carefully beveled to make an airtight joint when the cover is screwed on.

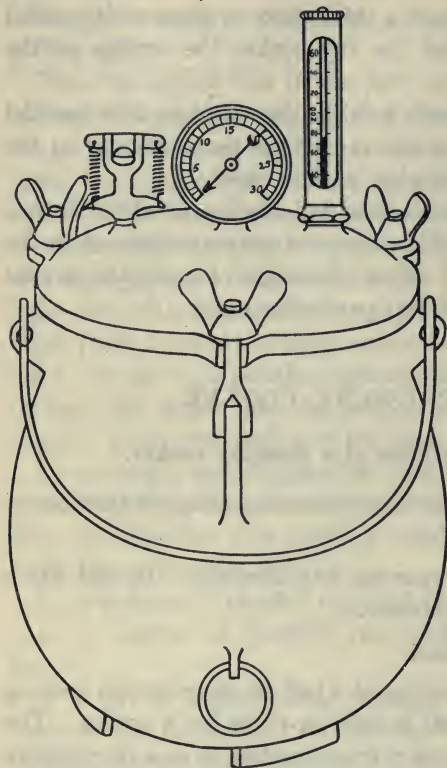

FIG. 52. — Pressure cooker with pressure gauge and thermometer attachments.

### *B. Use of the Cooker.*

It is used in the home (especially in high altitudes) for cooking all kinds of meats and vegetables, such as baked beans, which require a considerable length of time by the ordinary methods. The cooker is operated at about twenty pounds pressure and requires only about one-third as long to complete the cooking as in the open vessel and in this way saves both time and fuel. Pressure cookers are used in canning vegetables.

### *C. The Test.*

Remove the cover and examine the mechanism. (Handle with care.) Fill the cooker

one-third full of water. Place the cover on carefully and screw it down tight. Set the apparatus on the burner and heat till the thermometer passes the ordinary boiling point,  $212^{\circ}$  F. Now turn off the gas and with the point of a file lift the bar slightly from the safety-valve ball, letting steam exhaust till the pressure gauge indicator drops back to zero. (This operation will remove the air

from the cooker which would tend to make the thermometer reading low in comparison with the pressure.) Now light the stove again and record in a table the temperatures (boiling points) for each pound increase of pressure up to twenty pounds. For convenience in reading, avoid heating too rapidly. Then turn off the gas and allow the apparatus to cool.

1. Plot on a sheet of graph-paper the boiling point curve for the various pressures. Indicate pressures on the vertical line and temperatures on the horizontal line.

2. Pressure cookers are used extensively in Colorado. Explain.

3. Why is it difficult to cook potatoes or beans in an open vessel at high altitudes?

4. Is it possible to heat water above the boiling point in an open vessel? Explain.

5. Explain why the pressure cooker requires only one-third as long for the cooking process as an open vessel.

6. How is a pressure cooker apparatus used for making puffed wheat? See Butler's *Household Physics*.

7. Measure the diameter of the opening into which the lid fits. What upward pressure is exerted upon this lid when the gauge registers twenty pounds per square inch?

#### 54. PHONOGRAPH — A

To study the operation, theory, and mechanism of a phonograph.

**MATERIALS.** Phonograph; record; tuning fork; long and short needles; match; match box; piece of cardboard; cardboard box; thin wooden board (chalk box lid); lens; screw driver.

**A. Sound.** Sound is produced by a shock or disturbance in the air or other medium which causes waves comparable to water waves when a stone is thrown into a pond. When the air wave reaches the ear and affects the auditory nerve we hear sound. If the disturbances are produced very rapidly and in regular suc-

cession, the train of waves pounding against the ear-drum produces the effect of a musical tone.

1. Strike a tuning fork lightly and hold it close to your ear. What reasons have you for believing that the tuning fork is producing a train of waves?

2. How do the air waves differ when the fork is struck harder?

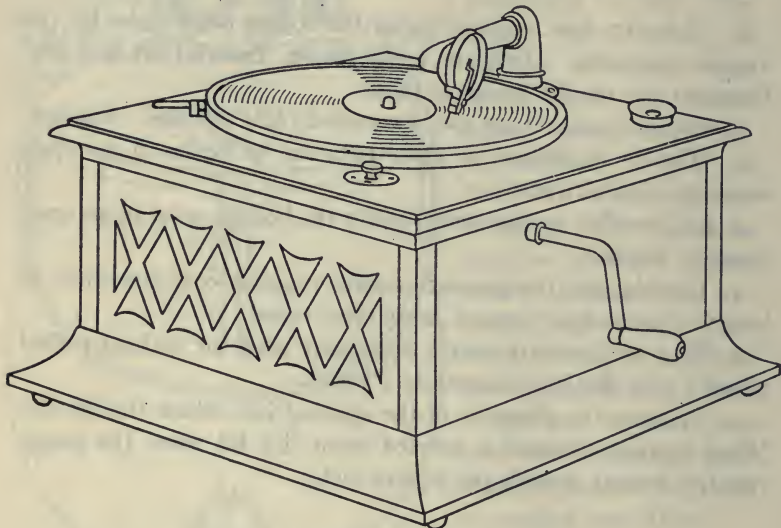

FIG. 53. — Phonograph with horn inclosed

3. What is meant by the statement that one fork has a "high pitch," and another fork "low pitch"?

4. Strike the fork and hold it against a table top, a cardboard box, or a thin wooden box. Explain the effect.

**B. How the Phonograph Sounds Are Produced.** Operate the instrument. Wind it carefully. Note the position of the starting lever. Place the record on the platform. In setting the needle on the record, place it gently. Do not scratch the record. If you are in doubt about any procedure inquire of the instructor. The sounds from a talking machine are produced by the vibrations

caused by microscopic waves in the groove of the disk. As the needle point follows these waving lines, it causes a thin mica diaphragm to vibrate by means of a lever to which the needle is attached. The vibration of the diaphragm produces the sound similar to the action of a telephone receiver diaphragm. This diaphragm is firmly held in a metal frame called the sound-box or reproducer. The lever which holds the needle is pivoted to the side of the sound-box and has its long arm fastened to the mica diaphragm of the sound-box. Any movement of the needle causes a corresponding movement of the diaphragm. In one type of record the needle moves "up and down," in another the needle follows a "side to side" movement. In the Victrola and the Columbia Graphophone the indentations run "side to side," in the Pathé and the Edison they run "up and down." Examine the record with a magnifying glass.

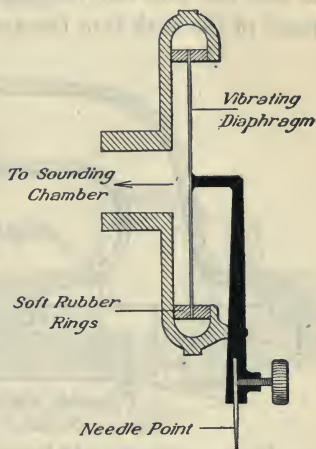

FIG. 54. — Sound box for "side to side" movement of needle.

5. What is the position of the diaphragm when the indentations run "side to side"?

6. Explain why the needle arm of the lever is shorter than the diaphragm arm.

7. If the indentations run "up and down," how must the diaphragm be set, — vertical or horizontal?

8. When a short needle is used it shortens the needle arm. What effect has this upon the movement of the diaphragm arm and consequently upon the tone?

**C. The Needle.** Needle points are commonly made of steel, wood, tungsten, or diamond. The two conditions which limit any

make of needle are the wearing away of the needle and the wearing away of the record. Either effect mars the music. Too dull a point will injure the sides of the grooves and too sharp a point will wear a track of its own.

Push the sound-box aside. Sharpen a match stick and hold it in the groove with your fingers. Cut two slots near the edge of a piece of cardboard five inches square and push the match stick in one slot and out the other to hold it firmly. Now place the point of the stick into the groove.

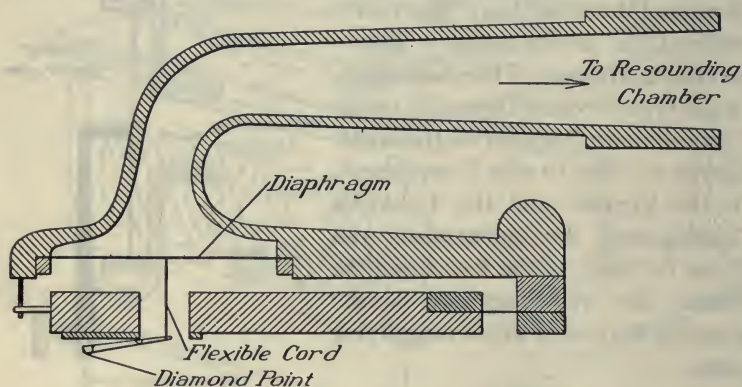

FIG. 55. — Sound box for "up and down" movement — Edison phonograph.

9. Explain how a thin board fastened to the needle makes the sound louder.

10. Drive one of the metal needles through a thin wooden board (chalk box cover). Explain why a metal needle produces a louder tone than a wooden needle.

11. What are some defects of wooden needles?

12. Why should some needles not be used more than once?

13. Play a record with a short, stubby needle, then try a long slender needle. Why is the former called full-tone and the latter half-tone?

14. Why are tungsten or diamond point needles desirable?

## 55. PROJECTION LANTERN — A

## Nitrogen Lamp Type.

To operate projection lanterns and study their optical and electrical principles.

**MATERIALS.** Transparent projector (nitrogen lamp type); screen; ammeter; opaque projector (nitrogen lamp type).

*110 volt electric current outlet.*

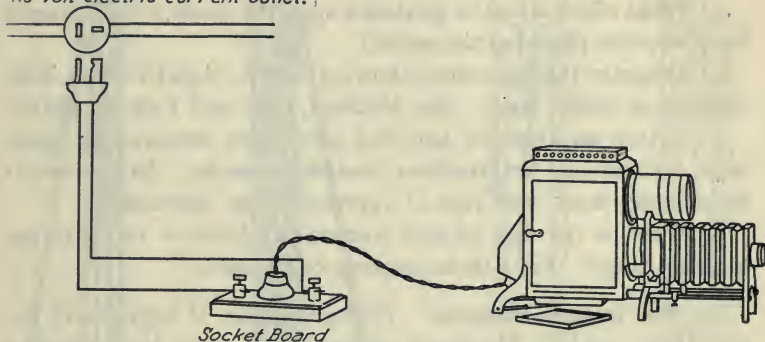

FIG. 56. — Wiring for a nitrogen lamp projection lantern.

**A. The Transparent Slide Projector — Stereopticon.** Connect the nitrogen lamp projector to a lamp socket on the 110-volt line. Note that the essential parts are — objective lens, object (slide), condensing lens, and source of illumination. Place a slide in position and adjust the objective lens to secure the sharpest image on the screen. Adjust the position of the nitrogen lamp to secure an even distribution of light on the screen and maximum illumination.

1. If the screen is moved nearer the apparatus, how must the objective lens be moved to produce a sharp focus?

2. In focusing a camera, if the object is moved closer, how should the camera lens be moved?

3. How does the human eye secure a sharp focus on the retina for both close and distant objects? Refer to texts.

4. Note the two condensing lenses situated between the nitrogen lamp and the slide. They may be considered two halves of a thick double convex lens. Their purpose is to concentrate the diverging rays from the lamp upon the slide (object). To cast a successful image upon the screen the object (slide) must be brilliantly illuminated. How would removing the condensing lenses affect the image?

5. What effect would be produced upon the image if the nitrogen lamp were not placed at the center?

6. Diagram the apparatus, showing screen, objective lens, slide condensing lenses, lamp. See Millikan, Gale and Pyle, or Butler.

7. Attach an ammeter and find how many amperes the lamp takes. (*Caution. Get directions from the instructor. Do not connect the ammeter until your plan is approved by an instructor.*)

8. What is the cost of this current per hour at 10 cents per kilowatt hour? Volts times amperes equal watts.

**B. The Opaque Projector.** Nitrogen lamps of high power are sometimes used to illuminate an opaque picture, for projecting its image on the screen. Small types of this apparatus are known as post-card projectors. Larger images are obtained with a brilliant carbon arc light and a very large objective lens. With this device pictures may be produced in colors.

9. Diagram one type of opaque projector and indicate parts—condensing lens, objective lens, and object. See Black and Davis or Hoadley.

10. Explain why a larger lens is necessary with the opaque projector than with the transparent projector. What effect has a larger lens upon the image?

11. What effect is produced upon the image by moving the source of illumination farther away from the object?



## 56. THE PULLEY

To study the operation of a pair of triple tackle blocks in lifting a one-hundred pound weight.

**MATERIALS.** Pair of triple tackle blocks; large spring balance, two fifty-pound iron weights; three-eighths inch rope (sash cord).

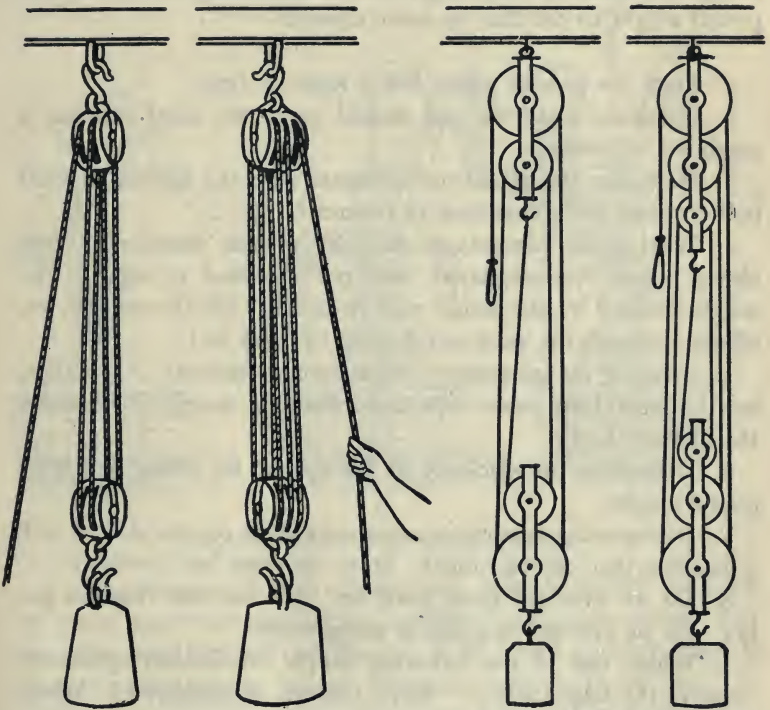

FIG. 57. — Pulleys with weights supported by four strands and by six strands. For simpler pulleys refer to textbooks.

**Operating a Set of Pulleys.** NOTE. In the use of a system of pulleys the ratio of weights required to establish a condition of balance depends upon the number of strands of rope supporting the movable block. In the practical application of this mechanism

for lifting heavy weights the ideal conditions never hold. The efficiency is very much reduced by friction in the pulley bearings and in the rope.

Suspend the two weights from the movable block of the system of pulleys. Attach the spring balance to the power side and pull downward till enough force is applied to cause the 100-pound weight to continue to move upward.

1. State the general pulley law. Refer to text.
2. Calculate what the pull should be in the ideal case for a condition of balance.
3. How does the actual pull compare with the calculated ideal pull required for a condition of balance?
4. What is the percentage efficiency of this machine? (Efficiency equals the calculated ideal pull required to support the weight divided by the actual pull required to lift the weight; or, efficiency equals the work out divided by work in.)
5. Allowing for inaccuracy on account of elasticity in the rope, how far should the power rope move when the weight lifted moves through one foot?
6. Determine the efficiency of the system for lifting one fifty-pound weight.
7. Disregarding friction, is more work done on one side of such a machine than on the other? State the work law involved.
8. Do we ever get more work out of a machine than we put in? Do we ever get as much in useful work?
9. Which one of the following simple mechanical appliances involves the least friction — lever, pulleys, or jackscrew? Which has the greatest friction?
10. Suggest two means of reducing friction in bearings. It is usually not considered advisable to use a block of more than three pulleys because of friction in the bearings.
11. Mention at least two practical situations in which pulleys might be used for lifting.

## 57. THE PUMP — KITCHEN LIFT PUMP

To study the action of a pump.

**MATERIALS.** Kitchen suction pump; wrench; two large jars or pails.  
**Parts** — cylinder; piston (plunger); piston-valve; foot-valve.

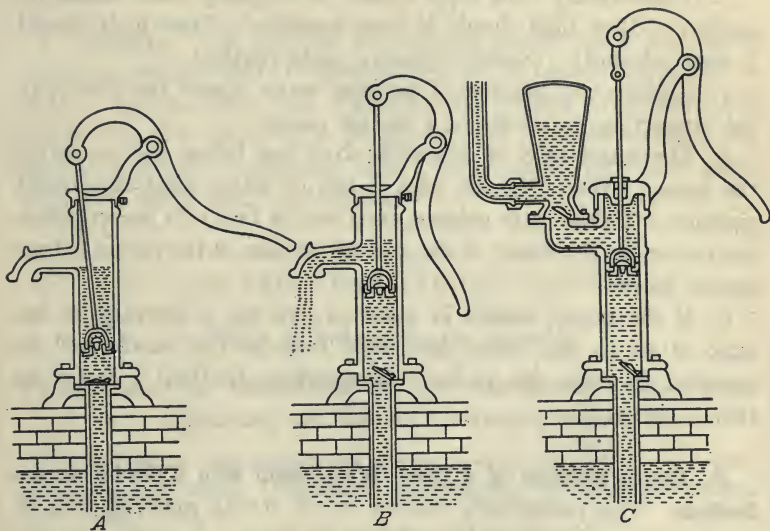

FIG. 58. — The lift pump and the force pump.

**A. The Parts and their Operation.** With a wrench take the lift-pump apart and examine the cylinder, piston, and valves. Put the parts together and operate it. A lift pump (suction type) is of practical value for lifts of not more than 20 to 25 feet. It is difficult to obtain a sufficient vacuum in the cylinder for higher lifts. For higher lifts it is necessary to place the cylinder near the surface of the water or under the water, with a rod reaching down through the lift-pipe to the cylinder at the bottom of the well. In such cases it is preferable to have the cylinder under water.

1. Make two diagrams, one showing the valves as the piston moves upward, the other as it moves downward. Explain the operation.
2. How does the action of a lift pump depend upon the pressure of the atmosphere?
3. Theoretically how high should a lift pump raise water by suction? How high should it raise mercury? How high should it raise alcohol? (Specific gravity, eight-tenths.)
4. Explain the practice of pouring water above the piston to aid in starting the action of a suction pump.
5. The water level in a well is sixty feet below the mouth of the pump. When the lift pipe is full of water what downward pressure will this water column exert on the face of a pump piston located under the water, if the area of the face of the piston is four square inches?
6. If the pump handle in question five has a leverage in the ratio of six to one, what downward force at the handle will be required to raise the piston (disregarding friction)? Refer to text — levers.

**B. Characteristics of a Deep Well Pump with Cylinder at the Bottom.** The pump-body should be of strong material and of good workmanship to withstand high pressure. A good pump for hand use should have a stroke of from six to ten inches with rocking fulcrum. The piston rod should move in perfect alignment. The handle leverage should be approximately six to one and the lift pipe not less than one and one-half to two inches diameter. A small pipe offers too much friction. It should be so constructed that the valves and piston are easy of access for repair. When the pump is exposed to freezing temperatures, it should have a small drain valve below the floor to allow the water to slowly drain out from above the frost line and prevent freezing. The lifting force required in such a pump will depend chiefly upon two conditions — the height to be lifted and the size of the cylinder.

The size of the cylinder and the length of stroke determine the amount of water lifted with each stroke. The cylinder of a good pump should be either of brass or brass-lined, because iron, in time, becomes rusted. This results in leakage around the piston.

7. Diagram a deep well pump. See *Mechanics of the Household* — Keene.

C. **Repairs.** The parts of an ordinary pump which need most attention are the leather valve parts and the leather lining of the piston. In the deep well, high pressure pumps these parts are metal. Leather parts of a pump may be renewed by any one having ordinary mechanical skill. The leather for these parts should be fairly thick and pliable.

## 58. SAUCEPAN CONDUCTION

Effect of differences in material.

**To determine the efficiencies of three saucepans, enamel ware, aluminum, and copper, for heating water.**

**MATERIALS.** Gas meter; gas burner; four-quart saucepans of enamel, aluminum, and copper; Fahrenheit thermometer; copper quart measure; screw clamp; clock.

**NOTE.** For diagram of apparatus refer to Experiment 41, Gas Stove Burner.

To what extent do differences in material affect the amount of heat conducted through the walls of a four-quart vessel? (The gas flow is kept constant at the rate of one cubic foot in four minutes.)

A. **Attaching the Meter and the Burner.** Connect a piece of rubber tubing from the gas cock to the side of the meter marked "inlet." Attach the burner to the other side of the meter. Place a screw clamp on the tube between the meter and the burner. (*Caution. Allow a quarter of a cubic foot of gas to flow through the meter before lighting.*) Adjust the clamp by opening and closing so

that exactly one cubic foot of gas flows through the meter in four minutes as indicated by the second-hand of the clock.

Measure carefully two quarts of water and heat it in a four-quart saucepan to  $75^{\circ}$  F. Stir to insure a uniform temperature. When the temperature of the water reaches  $75^{\circ}$  F., record the reading of the gas meter. Place a cover on the vessel and allow the heating to continue till one cubic foot of gas has been consumed. Readjust the screw clamp each minute to keep the meter hand in step with the second hand of the clock. Remove and stir, noting the final temperature.

1. How many B.T.U. passed through the walls of the vessel into the water? (Pounds times degrees rise.) (One quart of water weighs two and eight-hundredths pounds.)

2. What per cent of the total heat of the flame entered the water? (One cubic foot of gas gives out 600 B.T.U. — heat of combustion.) This result will represent the thermal efficiency of the saucepan.

3. What principle of heat is represented in the transfer of heat from the flame through the metal to the water in the vessel?

**B. Aluminum Vessel.** Repeat the experiment, using an aluminum vessel.

**C. Copper Vessel.** Repeat the experiment, using a copper vessel.

4. Arrange data in columns as follows: starting temperature, final temperature, cubic feet of gas consumed, B.T.U. generated by the gas, B.T.U. received by water, percentage efficiency.

## 59. SEWING MACHINE — A

To study the mechanical operation of a sewing machine.

MATERIALS. Singer machine No. 20.

Locate the following parts: balance wheel, the large needle bar lever, needle bar, the presser bar and presser foot, presser bar lifter, feed dog carrier and feed dog, looper, stitch regulator.

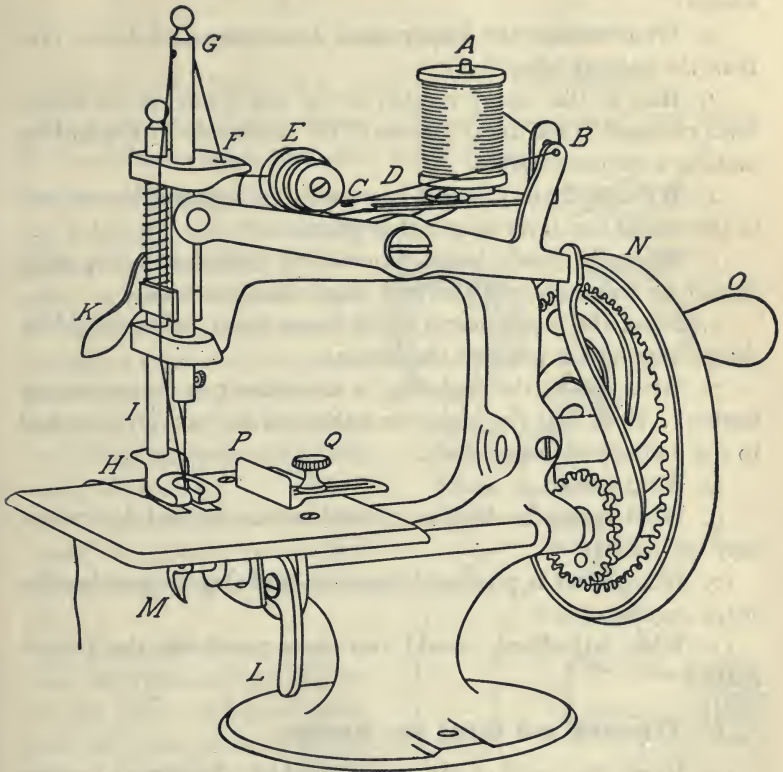

FIG. 59. — Singer sewing machine No. 20.

- |                               |                             |                        |
|-------------------------------|-----------------------------|------------------------|
| A—Spool Pin                   | F—Thread Hole in Arm        | L—Stitch Regulator     |
| B—Thread Pull-off             | G—Thread Hole in Needle Bar | M—Looper               |
| C—Thread Hole in Nipper Lever | H—Presser Foot              | N—Balance Wheel        |
| D—Nipper Lever                | I—Presser Bar               | O—Balance Wheel Handle |
| E—Tension                     | K—Presser Bar Lifter        | P—Guide                |
|                               |                             | Q—Guide Screw          |

1. Why do some mechanical devices have heavy balance wheels?
2. What causes the looper shaft to revolve at a faster rate than the balance wheel?
3. How is the rotary motion of the cog wheel on the looper shaft changed to the linear motion of the needle bar? Explain by making a simple diagram.
4. What mechanical result is obtained by making the one arm of the needle bar lever longer than the other?
5. When the needle bar is approaching its highest point, what should be the motion of the feed dog? Explain why.
6. When the needle bar is at its lowest point, what should be the position of the point of the looper?
7. What causes the feed dog to move away from the person sewing? Note that the looper and the feed dog cam are attached to the end of the looper shaft.
8. What pushes it back?
9. What varies the distance through which the feed dog carrier may be moved?
10. What effect is produced upon the feed dog by pushing the stitch regulator up?
11. What adjustment would you make to obtain the longest stitch?

### **C. Threading and Oiling the Machine.**

12. Name the parts of the machine which the thread touches in passing from the spool to the needle.
13. Locate and list the places on this machine which involve friction and on which oil might be put.
14. What are two important advantages obtained by the proper oiling of a sewing machine?



## 66. WATER MOTOR — A

To study water motors and water power.

MATERIALS. Water motor; gallon measure; quart measure.

A. **Calculated Horse Power.** Operate the motor and catch in the gallon measure the water which it uses.

1. With a clock and a gallon measure, find how many seconds are required for one gallon of water to pass through the motor. At this rate find how many cubic inches of water pass through the motor in a minute of time. (One gallon equals two hundred and thirty-one cubic inches.)

2. Note the pressure at this faucet in pounds per square inch while the motor is in operation.

3. Find the foot-pounds of work represented per minute by the cubic inches of water used and the pressure at the faucet. (Divide the number of cubic inches per minute by twelve to get feet of water with cross section of one square inch. Multiply by the pressure in pounds per square inch to get foot pounds of work represented per minute.)

4. Calculate the horse power represented by this amount of work per minute. (Foot pounds done per minute divided by

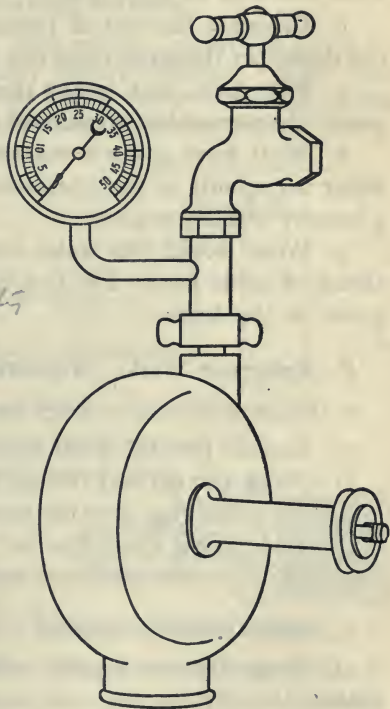

FIG. 60. — Water motor with pressure gauge attached.

33,000.) Waterwheels do not develop all the power represented by the water used. They are usually from seventy to ninety per cent efficient. The actual horse power delivered by a motor should be determined by a brake test. Efficiency equals work out divided by work in, or power got out divided by power put in.

5. If this motor had an efficiency of seventy-five per cent, what would be its horse power?

6. Calculate the cost of running the motor for ten hours at one dollar per thousand cubic feet of water.

7. How much work in foot pounds is represented by a dollar's worth of water at the pressure of the faucet? *cup*

8. What horse power is represented by a flow of six gallons of water per minute at sixty pounds pressure? This would operate a laundry washing machine.

9. What would this water cost per hour at one dollar per thousand cubic feet? List two or more possible uses for a water motor in the home.

### B. Reference Work. Waterwheels and Water Power.

*a. Practical Physics* — Black and Davis.

10. Explain how the water motor works.

11. Name two old and two modern types of waterwheels.

12. To which type does the ~~faucet~~ <sup>supply</sup> water motor correspond?

13. Under what conditions are Pelton wheels most commonly used and under what conditions are turbines most commonly used?

*b. General Science* — Barber.

14. Name the two biggest water power plants in the United States.

15. What horse power is developed at Niagara?

16. About how far from these great hydro-electric plants is it profitable to transmit this power by electricity?

17. To what city and how far is most of the power generated at Keokuk sent?

## GROUP III. EXPERIMENTS

## 61. ALTERNATING CURRENTS

NOTE. This experiment should be preceded by the experiments on the electric motor and the electric generator.

## To study alternating currents.

MATERIALS. Pocket compass; large steel file, one in. wide by ten in. long, magnetized; telephone magneto; battery voltmeter; electric bell; dry cell. Motor-generator set used in Electric Motor B with alternating current armature. (Part of this apparatus must be obtained from the instructor.)

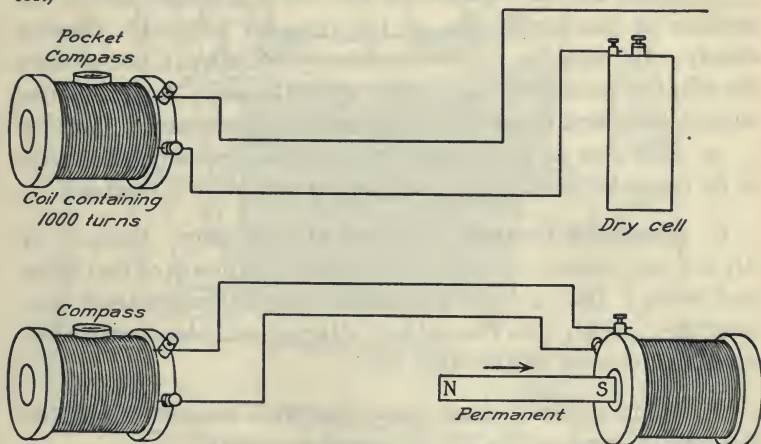

FIG. 61. — Apparatus and wiring for the study of alternating currents.

A. Introductory Experiments. Take the two large coils off the motor-generator apparatus and place them on the table. Connect two insulated wires each three feet in length to the terminals of one of these coils. Place the coil on the table in position so that it lies with opening horizontal. Set the pocket compass on the top of the coil. Move the coil in such position that its opening stands east and west.

1. Touch the free ends of the two wires to the two terminals of a dry cell. Does the needle on the coil remain parallel to the wires of the coil? What position does it take while the dry cell current is flowing through the coil?

2. What effect is produced upon a coil by a current passing through it?

3. What causes the compass needle to change its position when a current passes through the coil?

4. How can you reverse the direction of current flow through the coil?

5. What effect has this upon the polarity of the coil?

6. When the current through the coil is reversed, how is the position of the north pole of the compass affected? Observe closely. By reversing the flow of this dry cell current, you produce the effect of an alternating current upon the coil. An alternating current flows first in one direction, then in the opposite direction.

7. How does an alternating current differ from a direct current in its magnetic effect upon a coil through which it is flowing?

**B. Alternating Currents Produced Mechanically.** Remove the dry cell and connect the two coils together by means of two three-foot wires. Pass a large permanent magnet (magnetized large steel file) quickly into the coil just attached and observe the effect upon the compass on the other coil.

8. What evidence have you that this magnetism cutting through the turns of the coil generated a current?

9. Quickly pull the permanent magnet out of the coil. What effect did this produce upon the other coil?

10. When a magnet approaches the opening of a coil the current flows in one direction and when it recedes from the coil the current flows in the opposite direction. How can you prove this? If the coil of wire moves instead of the magnet, the same effect is produced. This illustrates the fundamental operation of all mechanically generated currents in dynamos and magnetos.

### C. The Telephone Magneto.

11. Explain how this device produces an alternating current. Connect a small lamp to it and see if it gives current

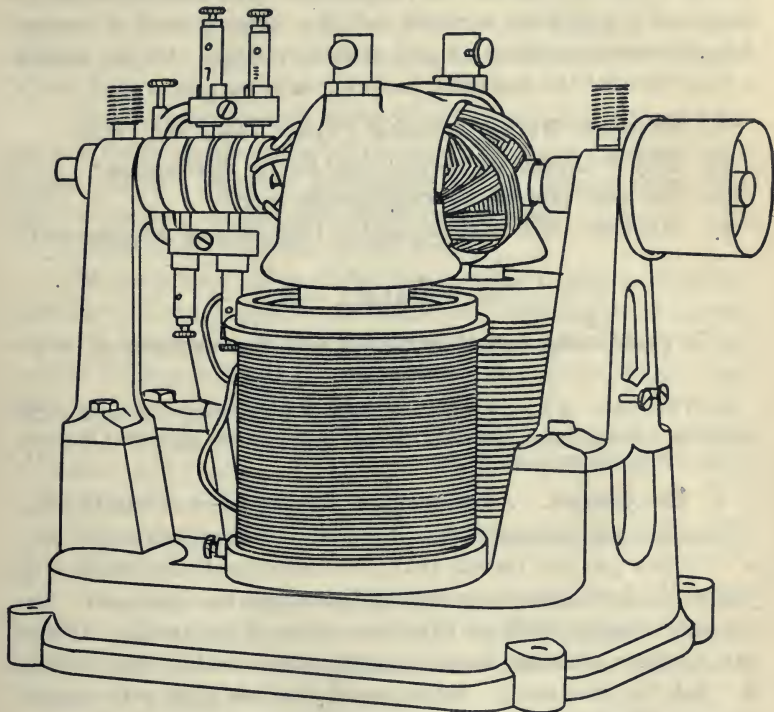

FIG. 62. — Generator with alternating current armature.

enough to light the lamp. Magnetos are used for ignition purposes on gas engines, and for ringing some types of telephone bells.

12. Connect the telephone magneto to a battery voltmeter and operate it. What evidence have you that the current it produces flows in pulses or alternates?

**D. The Alternating Current Generator.** Put the coils back on the motor generator apparatus and set the alternating current armature in position. Send the current of two dry cells through the field coils to produce the magnetism. Run the armature by means of a belt from a motor or some other source of power. Ask the instructor for a lamp of suitable voltage. Do not attach a lamp without the instructor's advice, as it may be ruined.

**E. Reference Work** — *Practical Physics*, Black and Davis.

13. Why is alternating current used in city distribution?
14. For what purpose are transformers used?
15. What are some voltages used in long distance transmission?

## 62. CAMERA — B

To study some optical principles and the operation of a camera.

**MATERIALS.**  $4 \times 5$  focusing camera with plate-holder and rapid rectilinear lens; simple lens; foot rule; screen. (Part of this apparatus must be obtained from the instructor.)

**A. The Camera.** A camera is a delicate piece of mechanism. Handle it with extreme care. Do not try to manipulate any part of it unless you feel certain that you understand what to do. If you are in doubt about any manipulation, ask the instructor. Do not take chances with an expensive piece of apparatus. If any part of the mechanism does not seem to work readily, do not force it. Ask the instructor. Never touch the lens with your fingers or other object not especially intended for cleaning it.

Open the camera by pressing the button which holds the door shut. The instructor will then show you how to draw the lens out until the indicator reaches the focusing scale. In some cameras a small wheel at the side of the focusing scale enables you to move the lens in focusing, toward the ground glass (screen) or away from it, depending upon the distance from the lens of the object to be photographed. This distance is given in meters and in feet.

## B. Lenses.

1. Measure the focal length of one of the reading glass lenses by focusing the sun's rays to the smallest possible spot on a sheet of paper. Measure the distance in inches from the center of the lens to the point of focus. If the sun is not shining, get the focus of some distant object on the screen and measure the distance between the screen and the center of the lens.

2. Find the focal length of the camera lens. Set it toward the sun and focus on the center of the ground glass or focus on some distant object. Measure approximately the distance from the center of the lens combination to the ground glass.

3. What is the diameter of the lens?

4. What is the  $f$ -value of this lens? (The  $f$ -value is found by dividing the focal length by the diameter.) The highly corrected, expensive, anastigmat lenses are of large aperture, having a low  $f$ -value. These lenses make very bright images and take snapshots as rapid as one-thousandth of a second.

5. What is an achromatic lens? See Millikan, Gale and Pyle, or Carhart and Chute.

6. Diagram a two-piece achromatic lens.

7. What two kinds of glass are used in making an achromatic lens? Refer to texts.

8. The larger cameras and projection lanterns usually have double combination lenses known as "rapid rectilinear" lenses. Diagram and describe a rapid rectilinear lens. See Black and Davis or *How to Make Good Pictures*.

9. What is an anastigmat lens? Some of these lenses cost as much as fifty to a hundred dollars. They sometimes are composed of six or eight different lens parts. What are some of the advantages of an anastigmat lens? See *How to Make Good Pictures*.

10. Name three defects or aberrations of simple lenses made of a single piece of glass. See *The Wonder Book of Light* — Aberrations of Lenses.

11. Examine the shutter dial. How many different adjustments for timing of the exposure are available on this camera? Name them.

12. Examine the stop scale. Should the stop be set high or low for a very rapid exposure? Why?

13. If the stop is more nearly shut the picture is sharper than when it is wide open. What disadvantage is involved in closing the stop? When should the stop be opened? When closed?

C. **Focusing.** Focus the camera on some near-by object six or eight feet away. In focusing move the lens forward and back until the point of sharpest image is produced upon the ground glass. Focus sharp on an object at six or eight feet distance. Without changing the distance between lens and ground glass, observe the image of a building or other object at a distance of several hundred feet.

14. To make the focus sharp at the greater distance should the lens be moved toward the ground glass or away from it?

15. Make a simple diagram to illustrate these differences in focus. See *How to Make Good Pictures*.

## 63. CAMERA—C

### Exposing, Developing, and Making a Print.

#### To make a print from a negative.

**MATERIALS.** Negative; printing frame; Aristo Gold Paper (Eastman Kodak Co.); hypo; sodium carbonate; table salt; teaspoon; glass graduate (in ounces); one glass tray; two enamel trays. (Part of this apparatus must be obtained from the instructor.)

**NOTE.** Exposing, developing, and fixing the negative require too much technique and time to be done during the regular laboratory hour. This procedure will be described in brief below. If groups of six students can arrange to meet with the instructor at a convenient time outside of the regular class period the making of a negative may be demonstrated. As a reference book use *How to Make Good Pictures*, Eastman Kodak Co.



**A. Exposing, Developing, Fixing, and Washing the Negative.**  
(NOTE. This work is to be omitted except by special arrangement with the instructor at some special time.)

**Exposing.** For general outdoor work it is a good practice to keep the stop at some fixed point, as No. 8 stop, and become familiar with the shutter time required for changes in light intensities such as exposures in shade, in medium light, or in sunlight. For indoor work and for pictures taken in the evening, it is often necessary to open the stop wider and to increase considerably the time of exposure. Indoor exposures require about one hundred times as long as outdoor exposures if the stop opening is the same in both cases.

**Developing and Fixing.** The developing solution is made by taking eight ounces of water in a graduate with the contents of one developing tube. Stir with a clean glass rod until completely dissolved. Do not pour developer into the developing tray until the plate is in it. If developer is kept from one day to the next, keep it corked up in a bottle. (*Caution. Never put developer into a fixing tray or fixer into a developing tray. After putting your fingers in the fixing bath never put them into the developing solution without first washing them and drying with a towel. If a drop of the fixing solution gets into the developer it will be injured or ruined. Proceed slowly; be sure you know what to do; think before you act.*) The time for developing is ten to fifteen minutes. The developing solution (reducing agent) changes the white silver salt to black metallic silver. The white silver salt is changed to black silver metal only if it has been exposed to light. Those parts of the plate which have had no light are not blackened by the developer. The dark parts of a negative or print are silver metal. It is advisable to move the tray slightly while developing. The developing process must be observed with a ruby lamp. When the negative (picture) is completely developed, it is dipped in water and transferred to the fixing bath. The fixing solution is a solution of hypo (sodium thiosulfate) dissolved in water — one

ounce of salt to four ounces of water. Before beginning the developing, fill the fixing tray one-quarter full of fixing solution and set it aside for use when the plate is developed. The purpose of the fixing solution is to dissolve out of the emulsion all silver bromide which has not been changed to silver metal by the action of light and the developer. The fixing requires about fifteen minutes. The fixing is complete when all white has disappeared from the negative.

**Washing.** When fixing is completed, remove and place the plate in running water for one-half hour. Plates will discolor if not completely fixed or properly washed. After washing, stand the plate up to dry. When the emulsion is dry, prints may be made.

**B. Making a Print from a Negative.** Place the plate in the printing frame. Place a piece of Aristo Gold printing out paper (Eastman Kodak Co.) in the printing frame so that the emulsion sides of the paper and of the plate meet. Stand the printing frame facing the sun. The time of printing will depend upon the density of the negative and upon the brightness of the light. The progress of the printing may be observed by carefully releasing one side of the printing frame and raising the paper. This should be done in the shade. The print should be made considerably darker than is desired in the finished picture since it bleaches out in the fixing bath. The chemical principle is essentially the same as in the making of a negative.

**NOTE.** The more rapid developing papers require a dark room for developing, a developing solution and some practice in manipulation.

**C. Toning the Print.** Prepare the salt bath, the soda bath, and the fixing bath described below before beginning the work. (*Caution. Always use the glass tray for the fixing bath in order to keep hypo away from the developing and toning trays.*) "Printing out" papers, like Aristo Gold, usually require a toning bath, while "developing out" papers, like Velox, require a developing

bath similar to that of a negative. Aristo Gold requires a very simple toning procedure. (Always wash trays before and after using.) Place prints face downward in a solution of one-quarter ounce of table salt (level teaspoon) in sixteen ounces of water. Keep prints in motion until they turn to a purple tint (about ten minutes). Rinse in water containing enough sodium carbonate (sal soda) to make it feel smooth (level teaspoonful). Prints should remain in the soda bath about three minutes, then be removed to the fixing bath. This process gives a purple tone. If a carbon sepia tone is desired omit salt and soda baths. Wash prints directly in six changes of water and place them in the fixing bath.

**D. The Fixing Bath.** (*Caution. Prepare the fixing solution always in the same tray. Use the glass tray for fixing bath. Never make up a fixing bath in any other tray.*) Dissolve one ounce (four teaspoonfuls) of hypo (sodium thiosulfate) in eight ounces of water. Move prints about in fixing bath fifteen or twenty minutes, wash in ten changes of water. Dry between blotters.

**E. Reference Work.** *How to Make Good Pictures.*

1. What is meant by the term "orthochromatic plate"?
2. Why does a small stop opening on a common lens give a sharper focus than a large stop?
3. What type of lenses give sharpest pictures for large stops?
4. Under what conditions should a small stop be used?
5. State the speed and the uses of the fastest shutters.
6. Which gives greater depth of focus (focus for objects that are near and far), a large stop or a small stop?
7. Why should the sun not shine toward the face of the lens?
8. Give normal temperatures for developing and fixing baths.
9. If a plate were exposed to the light after it is developed and before it is fixed, explain why it would be ruined.
10. Why does a white dress appear black on a negative?
11. How does black on a negative produce white on the print?
12. State four directions preliminary to making a snapshot.

## 64. THE ELECTRIC DISK STOVE

## Heating Water — Cost and Efficiency.

To determine the cost of heating a quart of water from  $75^{\circ}$  F. to the boiling point,  $212^{\circ}$ , when heat is obtained from an electric disk stove.

MATERIALS. Disk stove; Fahrenheit thermometer; copper quart measure; 4-quart saucepan; socket; wires; gas-burner; clock.

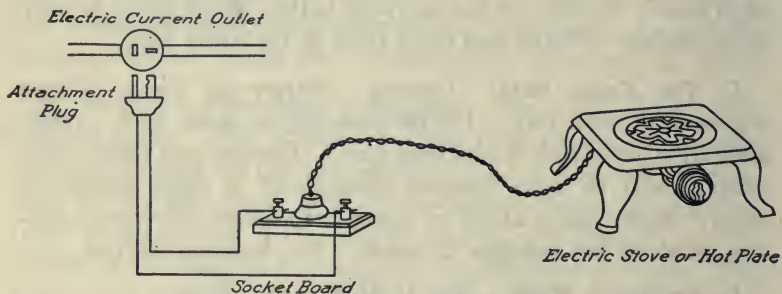

FIG. 63. — Wiring for the electric stove.

Assume that the amperage and voltage ratings on the label of the heating device are correct unless otherwise stated by the instructor. Complete wiring connections from the socket to the line terminals before attaching the stove. Current should be turned on and off from a heating element which uses three or more amperes by an attachment plug, not by screwing into a socket or by turning an ordinary button. The reason for this precaution is that a large current (amperage) produces a very hot spark and will melt the metal of the socket if it is not disconnected quickly and completely.

**A. Heating by Electric Disk Stove.** Measure carefully a quart of water into the saucepan. Heat this water to the starting temperature,  $75^{\circ}$  F., on a gas-burner. Stir to get a uniform temperature reading. When the temperature reaches  $75^{\circ}$  attach

the plug, sending current into the disk stove. (*Caution. Do not heat a disk stove for more than a few minutes without some vessel on it, as it may become overheated and ruined.*) Note the starting time on the clock and place the vessel of water with cover on the stove. Allow the heating to continue till the water reaches the boiling point as indicated by the evolution of steam bubbles (not air bubbles) from the bottom of the vessel. Note the stopping time and disconnect the heating utensil from the electric lines by pulling the attachment plug from its socket.

1. How many amperes of current does this device use?
2. What is the voltage of the line? Read the line voltmeter.
3. How many kilowatt-hours of electric energy were used? (Volts times amperes divided by one thousand and that result multiplied by the number of hours in operation.)
4. What was the cost of this heating at <sup>three</sup> ten cents per kilowatt-hour?
5. How many B.T.U. did the water receive? (Pounds of water times degrees rise.) (One pound equals four hundred and fifty-four c.c.)
6. How much heat was generated by the electric energy which you used? (One kilowatt-hour gives out thirty-four hundred B.T.U.)
7. What per cent of the total heat of the electric energy used entered the water? This result represents the heating efficiency of the operation.

### B. Electric Heating Elements.

8. <sup>make a</sup> Diagram the heating wires in an electric disk stove, a flat-iron, or an electric toaster. See Keene, Butler, or Hoadley.
9. What result would you expect if this device were attached to a current of half the voltage rated for its use?
10. Describe how the heating wires are insulated from the metal of an electric iron or toaster. See Keene.

## 65. THE ELECTRIC GENERATOR (DYNAMO)

To study the construction and operation of an electric generator.

NOTE. It is preferable to take the experiment dealing with the "Electric Motor" preliminary to this experiment. Handle apparatus carefully.

MATERIALS. Small generator, operated by hand power (L. E. Knott hand power dissectible dynamo and motor); small lamp; battery ammeter; battery voltmeter; electric bell; small motor; telephone magneto generator. (Part of this apparatus must be obtained from the instructor.)

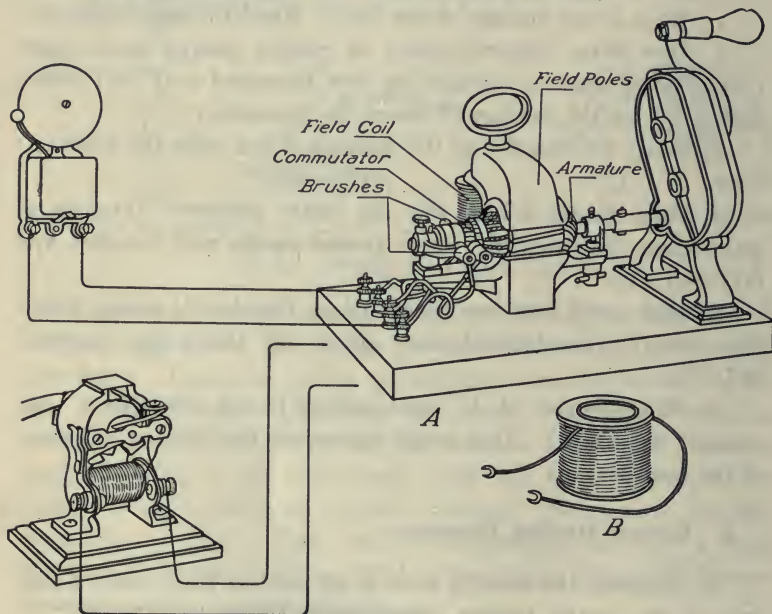

FIG. 64. — Electric generator.

**A. Explanation and Operation.** In construction the simple generator is the same as the simple motor. The simple generator is a device for revolving a coil of wire between the poles of a strong

electromagnet. When a magnet moves into a coil or away from it, a current is generated in the coil. Or if a coil revolves in the presence of a magnet, a current is generated in the coil. The coil cuts the lines of force produced by the magnet. (The wires leading from the coil must be connected to complete a circuit.)

Operate the small hand-power generator. Connect wires to it, causing it to ring a bell, light a small lamp, and run a small motor.

1. Attach a battery voltmeter to the terminals and measure its voltage at your maximum speed.

2. Attach a battery ammeter in series with a small motor, and measure the amperage which passes through it at your maximum speed.

3. How does varying the speed affect the voltage? As the voltage increases the amperage also increases through a given resistance.

4. Make two simple diagrams of generators showing series winding and shunt winding. See Black and Davis.

5. If a generator armature contains a commutator, will the current be direct or alternating?

6. What is the function of the field coils of an electric generator?

7. Of what material are the brushes in this small generator made? in large generators and motors?

8. How does a generator get its field magnetism? Refer to texts. At the beginning a very small amount of residual magnetism remains in the magnets from the last running to start the voltage in the armature, which in turn starts a small current.

**B. Telephone Magneto Generator.** Operate this generator and attach a small lamp. This device is sometimes used on telephone instruments for the purpose of ringing up the party at the other end of the line.

9. How does its field magnet differ from that of the regular generator?

10. If the armature shaft contains rings in place of a commutator, what kind of current does it deliver?

**C. Demonstration Generator.** The same apparatus used for the experiment with the motor should be used as a large generator. It may be operated by another motor or it may be connected by belt to a one and one-half horse power gas engine as a source of power.

11. With a suitable voltmeter measure its voltage. Ask instructor for the voltmeter.

12. Wire it as a shunt generator.

13. Attach a motor of proper size and measure the amperes of current which it consumes.

14. Name five essential parts of a generator. (Same as in a motor.)

15. Diagram a compound wound generator.

## 66. THE ELECTRIC IMMERSION HEATER

### Heating Water — Cost and Efficiency.

To determine the cost of heating a quart of water from  $75^{\circ}$  F. to the boiling point,  $212^{\circ}$ , when heat is obtained from an electric immersion heater.

**MATERIALS.** Immersion heater; Fahrenheit thermometer; copper quart measure; 2-quart vessel; socket; wires; gas-burner; clock. (Part of this apparatus must be obtained from the instructor.)

Assume that the amperage and voltage ratings on the label of the heating utensil are correct, unless otherwise stated by the instructor. Complete wiring connections from the socket to the line terminals before attaching the utensil. Current should be turned on and off from a heating element which uses three or more amperes by an attachment plug, not by screwing into a socket, or by turning a button. The reason for this precaution is that a large current (amperage) produces a very hot spark and will melt the metal of the socket if it is not disconnected quickly and completely.



A. **Heating by Immersion Heater.** Carefully measure one quart of water into the vessel. The water in the vessel should completely cover the heating element of the immersion heater. Heat this water to the starting temperature,  $75^{\circ}$  F., on a gas-burner. Stir to get a uniform temperature reading. When the temperature reaches  $75^{\circ}$  attach the plug, sending current into the immersion heater. (*Caution. Do not heat an immersion heater out-*

*110 volt electric current outlet*

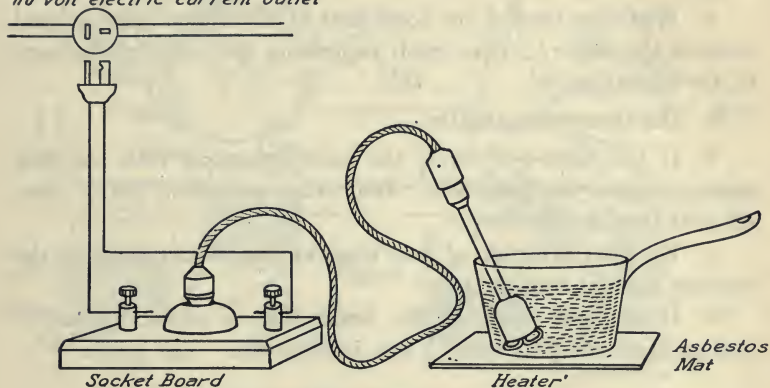

FIG. 65. — Wiring for the electric immersion heater.

*side of the water, as it may become overheated and ruined.*) Note the starting time on the clock and allow the heating to continue till the water reaches the boiling point, as indicated by the evolution of steam bubbles (not air bubbles) from the bottom of the vessel. Note the stopping time, and disconnect the heating utensil from the electric lines by pulling the attachment plug from its socket.

1. How many amperes of current does this device use?
2. What is the voltage of the line? See laboratory line voltmeter.
3. How many kilowatt-hours of electric energy were used? (Volts times amperes, divided by one thousand, and that result multiplied by the number of hours in operation.)

4. What was the cost of this heating at ten cents per kilowatt-hour?

5. How many B.T.U. did the water receive? (Pounds of water times degrees rise.) (One pound equals four hundred and fifty-four c.c.)

6. How much heat was generated by the electric energy which you used? (One kilowatt-hour gives out thirty-four hundred B.T.U.)

7. What per cent of the total heat of the electric energy used entered the water? This result represents the heating efficiency of the operation.

#### **B. The Immersion Heater.**

8. If you have performed the same operation with the disk stove, compare the two costs. Why is an immersion heater more efficient than a disk stove?

9. By what principle of heat transfer does heat pass from the heating element into the pan?

10. How might screwing this device from a socket instead of pulling apart the plug cause a fuse to blow out? See Butler.

## 67. ELECTRIC MOTOR — B

### Direct Current.

To study the construction and operation of electric motors. This experiment should be preceded by Electric Motor — A.

**MATERIALS.** Four dry cells; battery ammeter; wires; commercial types of motors; motor generator set; compass; screw driver; wrench.

**A. Construction of the Motor.** With a screw driver and wrench, disassemble the apparatus, removing the armature shaft, brushes, and field coils.

1. How many commutator segments has this motor?

2. How are the brushes held against the commutator when the motor is operating?

3. Of what material are the brushes made?

Reassemble the motor for operating. Wire it in series. Connect four dry cells in series with a battery ammeter and measure the amount of current the motor lets through with the voltage of four dry cells.

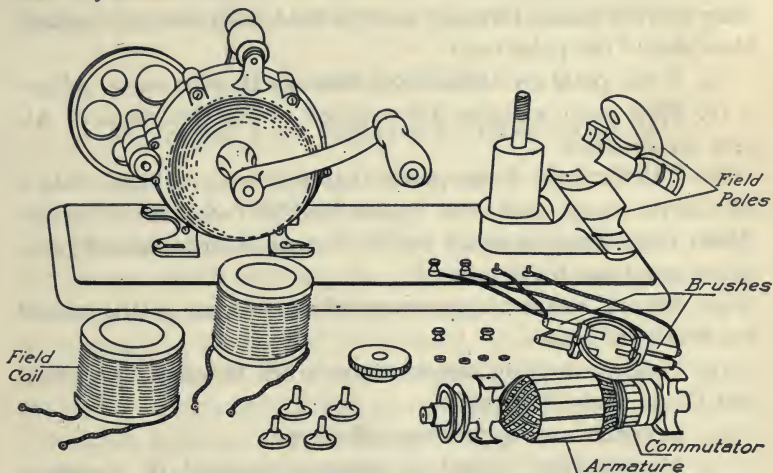

FIG. 66. — An electric motor or generator with parts disassembled.

4. What is the voltage of four dry cells?
5. What amperage passes through the motor at this voltage?
6. What is the resistance of the motor in series? Apply Ohm's law (volts divided by ohms equal amperes).

### B. Operation.

7. Do not attach this motor to the 110-volt line without having the wiring approved by an instructor. Calculate the amperage which would pass through this motor if it were attached to the 110-volt line without resistance. This amount of current would pass through it if the armature were not permitted to revolve. Note that a motor takes more current through it if the armature is not allowed to revolve, or if it is made to do work. Apply Ohm's

law. A motor should not get hot in operation. If a rheostat is needed, the instructor will give directions for attaching it.

8. What is meant by counter electromotive force, or counter voltage produced by a motor armature when it begins to revolve? See *Elements of Electricity* — Timbie. If the motor does not run when current passes through, test the field poles with a compass. How should the poles test?

9. If the poles are of like sign, how can they be made unlike?

10. How many amperes are required to run this motor? Attach an ammeter.

11. Calculate the horse power that this motor should have if all electric energy used were transformed into mechanical energy. (Volts times amperes equal watts. Seven hundred and forty-six watts equal one horse power.)

12. What is meant by percentage efficiency of an electric motor? See Black and Davis.

13. Diagram a shunt wound motor. See Hoadley, or Carhart and Chute under Dynamo.

14. Diagram a compound wound motor.

15. Measure the current in amperes required to operate a motor for some specific purpose, such as a fan motor, a vacuum cleaner motor, etc., and calculate its cost per hour. Ask the instructor for a suitable motor.

### C. Characteristics of Motor Winding — Shunt, Series, and Compound.

a. Shunt. This is the most common type of motor. It usually has a starting resistance through which the armature current must flow. The chief advantage of the shunt motor is that it has fairly constant speed with load or no load. It does not race except when the current through the field is excessively reduced, thus reducing counter voltage.

b. Series. Speed depends entirely upon the load. It should never run disconnected from its load, as it may increase in speed

till the armature bursts. Its common uses are in street railway cars, in fans, automobile starters, etc., where it is always attached. It furnishes a strong starting torque.

c. Compound. Motors are wound compound where load is subject to variations, and nearly constant speed is desired, as in operating shop machinery which are periodically thrown on and off.

## 68. GASOLINE ENGINE — B

### To operate a gas engine and explain its action.

MATERIALS.  $1\frac{1}{2}$  horse power gasoline engine on truck. See illustration of Gasoline Engine A, Experiment 42.

A. **Starting the Engine.** Fill the cylinder hopper with water and oil the cylinder and bearings. Use illuminating gas or gasoline. Before attempting to start the engine throw on the spark-coil lever, close the air-damper (to increase the suction if gasoline is used), and turn the fly wheels over compression. Open the air damper when the engine begins to explode. If the engine is properly timed, explosion should take place at or near maximum compression. If you are in doubt about the procedure have an instructor start the engine. (*Caution. Keep a safe distance from moving wheels and shafts.*) The engine will start more readily if the mixing valve is opened about two turns to let in a richer mixture at the start. When the engine begins to run the mixing valve should be screwed farther shut, otherwise the mixture may be too rich and cause smoking at the exhaust. If the mixture is too lean the engine will misfire, run slow, or "gasp for breath."

### B. The Mechanism and Operation.

1. Can a four-stroke engine explode every revolution? Explain.
2. In the four-stroke engine, what is the ratio of the cog teeth on the two wheels which operate the cam?
3. What is the function of the cam?
4. Name two parts that are operated by the cam rod.

5. Examine the governor. What runs it? What does it do to the cam rod when the speed becomes too great? Pull the balls apart and note how this stops the explosion when the engine is running. Set the speed lever in high, medium, and low.

6. What pushes the cam rod toward the crank shaft? What pushes it back again?

7. When the engine is running, note that the cam rod operates a valve by means of a lever at the end of the cylinder. Is this the intake valve or the exhaust valve? Why?

8. What is the purpose of the other valve? What causes it to open? What causes it to close?

9. What is the purpose of the water jacket around the cylinder? The water should be withdrawn from it in cold weather when the engine is idle. Why?

10. When the engine speeds up to maximum, what stops the sparking mechanism?

11. When the engine speeds up to maximum, what keeps the exhaust valve open?

12. When the exhaust valve is kept open, does the piston draw in mixture through the intake valve? Explain.

13. Why do gas engines need such heavy flywheels?

14. List some uses in the home or on the farm for gasoline engines.

(NOTE. After stopping the engine, throw out the switch at the spark coil in order to avoid wasting the battery current.)

## 69. HORSE POWER — A. ELECTRIC MOTOR

To determine the horse power of an electric motor.

MATERIALS. Small 110-volt motor attached to a ring stand; two spring balances; belt brake; speed indicator. (Part of this apparatus must be obtained from the instructor.)

A. Horse Power. The horse power output of an electric motor, an engine, a water wheel, etc., refers to how much work

the source of power is able to do per second or per minute. The unit of work is the foot pound or the lifting of one pound vertically through one foot distance. In general, work done equals pounds lifted times the vertical distance lifted in feet. If a motor or an

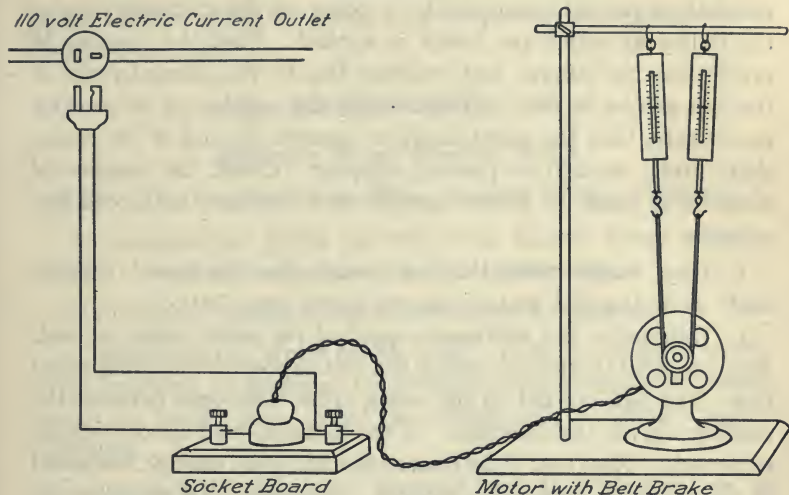

FIG. 67. — Wiring and apparatus for determining the brake horse power of an electric motor.

engine is able to lift 33,000 pounds through a vertical distance of one foot in one minute, it is able to do work at the rate of one horse power. A one horse power motor or engine can do 33,000 foot pounds of work per minute. It can lift one pound 33,000 feet in one minute, or 33,000 pounds through one foot, etc. To determine the horse power of an engine or motor, find how many foot pounds of work it can do in one minute, and divide this result by 33,000.

1. How much work is done by lifting one hundred pounds vertically through eight hundred feet?

2. What horse power is required to lift three thousand pounds one thousand feet in five minutes? Find how much work is done in one minute and divide by 33,000.

**B. Horse Power Measured with a Belt Brake.** The belt brake attachment makes it possible to determine how many pounds the motor can pull in operation. The distance in feet through which this pull is exerted may be found by determining the number of revolutions per minute made by a point on the circumference of the pulley at which the brake is applied. Find the number of revolutions per minute, and multiply this by the circumference of the belt groove in feet. To determine the number of revolutions per minute, hold the speed indicator against the end of the motor shaft firmly enough to prevent slipping. Count the number of revolutions made in fifteen seconds and calculate the speed per minute.

3. How many revolutions are made by the speed counter shaft while the dial makes one revolution (gear ratio)?

4. Determine the maximum speed of the motor with no load. Apply a slight tension by raising the belt support on the ring stand rod. The pull exerted on the motor is the difference between the readings on the two balances. If the balances read ounces, reduce to pounds. Note that if the tension is made great enough, the speed of the motor is very much reduced. (*Caution. Do not allow the motor to run longer than fifteen seconds at one time with tension on the pulley as the friction on the pulley produces heat, and the motor may be injured by overheating.*)

5. Make at least five measurements of the pounds pull and the speed per minute (number of revolutions in fifteen seconds  $\times$  four), beginning with a very slight pull and increasing with each measurement so that the last measurement is made with enough tension to cause the motor to run at a comparatively slow speed. Multiply the pull in each case by the corresponding speed per minute. One of the products should represent the maximum. If the last product is greatest, you have not made the tension great enough and more readings should be taken. In a series of five products, the third or fourth should be greatest. Make a table showing the data for these five measurements.



6. From the pounds pull and the revolutions per minute of the maximum, calculate the work done per minute. (Pounds times circumference of pulley in feet, times speed per minute.)

7. From the result in question 6, what is the maximum horse power of this motor? (Work in foot pounds done per minute, divided by 33,000.)

## 70. HORSE POWER — B

### Efficiency of an Electric Motor.

NOTE. This experiment should be preceded by Horse Power — A.

To compare the power got out of an electric motor with the electric power put in — efficiency.

MATERIALS. Apparatus used in Horse Power A; ammeter.

**A. Attaching the Motor to the Line.** With the help of an instructor attach an ammeter for measuring the amperes of current which the motor uses. Read the voltage on the laboratory line-voltmeter.

1. Does a motor use more amperes when it is running free, or when a brake is applied and it is required to do work?

**B. Calculating the Efficiency.** Refer to your data in Horse Power A. Find the tension on the balances representing the maximum product of pull and speed per second. Set the balances so that the motor operates under this same pull. Turn on the current and note the amperage consumed at this tension of the balances. (*Caution. Do not operate the motor longer than necessary to make the reading. Avoid overheating on account of friction of the belt.*)

2. How many watts of power does this motor consume? (Volts times amperes equal watts.)

3. What horse power is represented by this current? (One horse power equals 746 watts.) This represents the power put in.

4. What horse power was got out according to the determination in Horse Power A? Refer to data.

5. How does the power got out compare with the power put in? Efficiency equals power got out divided by the power put in, or work out divided by work in.

### C. Problems and References.

6. A vacuum cleaner motor requires about one and a half amperes and one hundred and ten volts. What is its horse power output if its efficiency is eighty per cent?

7. A motor for operating a laundry washing machine requires one and two-tenths amperes and one hundred and ten volts. If its efficiency is ninety per cent, what is its output in horse power?

8. A trolley car motor uses fifty amperes at five hundred volts. If its efficiency is eighty per cent, what horse power does it apply to the car?

9. One horse power equals how many watts?

10. What is the horse power of the following, — a railroad locomotive, a steamboat engine, an average horse, an average man? See Millikan, Gale and Pyle.

## 71. HUMIDITY — A

### Relative Humidity Determined from the Dew Point.

To find the relative humidity of the air in the room at a particular time.

NOTE. This experiment should be preceded by the experiment, Dew Point.

MATERIALS. Data of Dew Point experiment.

A. **Relative Humidity** refers to the degree to which the air is saturated with moisture at any particular time. Fifty per cent humidity means that the air has fifty per cent as much moisture as it can hold at the given temperature. Just before and during a rain the air may be between eighty and a hundred per cent saturated. Such common expressions as "muggy air," "damp air," "depressing air," "dry air," refer to the amounts of mois-

ture which the air contains at particular times. We have examples of high humidity in summer before a thunderstorm. In winter, when cold air is heated by hot-air furnaces, steam or hot-water radiators, the humidity in living rooms sometimes falls as low as ten or fifteen per cent. When cold air is heated its relative humidity decreases because it can then hold so much more moisture.

It is commonly considered that a relative humidity of approximately fifty per cent or between forty and sixty per cent is most conducive to health and comfort. Living rooms and schoolrooms on cold winter days often show relative humidities of ten per cent. This humidity is lower than that of the driest desert regions of the earth. This extremely dry air is said to contribute to nasal, throat, and lung diseases by drying the delicate membranes so that disease germs find lodgment. The woodwork and furniture of homes dry out and cracks appear. These close up again with the moist air of summer.

*B. Maximum amounts of water vapor in pounds which one thousand cubic feet of air can hold at different temperatures. (This means the amount of water in the air when it is completely saturated, or one hundred per cent humid, or at the dew point.)*

TEMPERATURE DEGREES F.	POUNDS OF WATER	TEMPERATURE DEGREES F.	POUNDS OF WATER
0	.08	64	.93
5	.10	68	1.06
15	.15	72	1.21
20	.18	76	1.32
25	.23	80	1.55
30	.27	84	1.75
35	.34	88	1.98
40	.41	92	2.23
44	.47	96	2.51
48	.54	100	2.82
52	.62	152	10.60
56	.71	200	28.85
60	.82		

**C. Calculation of the Relative Humidity from the Above Table.** Refer to the data of the experiment on "Dew Point" and note the dew point temperature of the air in the room according to your determination. Find how many pounds of water one thousand cubic feet of air can hold at the dew point temperature. This is the amount of water actually in the air at the time. Now refer to the table again and see how much water a thousand cubic feet of air can hold at the room temperature. The relative humidity is the amount of moisture in the air divided by the amount which the air can hold at that temperature.

1. What was the relative humidity of the air in the room by the dew point method?

**D. Reference Work.** *General Science.* Barber.

2. How can the necessary amount of water be evaporated to properly humidify a room that is heated by a stove?

3. Diagram a hot-air furnace with a humidifying device. Explain it briefly.

4. How much water per hour may be necessary to properly humidify a typical schoolroom?

5. Would you expect a pan of water on a radiator to properly humidify a room? Explain.

## 72. HUMIDITY — B

### Relative Humidity Determined by Means of a Wet and Dry Bulb Hygrometer.

To find the relative humidity of the air in the room at a particular time.

**MATERIALS.** Wet and dry bulb hygrometer; Humidity Tables. See *General Science*, Barber, or United States Weather Bureau Bulletin No. 235, Psychometric Tables.

**A. The Wet and Dry Bulb Hygrometer.** This type of hygrometer consists of two thermometers. The bulb of one thermometer is kept moist by means of a wick which stands in water. The

water should be at the temperature of the room. Evaporation from the wet bulb reduces the wet bulb thermometer reading below that of the dry bulb.

If the air is dry (low humidity), the evaporation will be more rapid and the wet bulb thermometer will read low. If the air contains a high percentage of moisture, the evaporation will be less and the difference in reading between the two will be less. This difference between the reading of the dry bulb and the wet bulb may be used for determining humidity. Fan the wet bulb for about a minute, then read its temperature. With the dry bulb reading and the difference between the two bulbs refer to a relative humidity table and find the percentage humidity. See Barber's *General Science*.

1. What was the relative humidity by the Wet and Dry Bulb hygrometer method?

2. Why should the water in the reservoir be at room temperature?

3. Give a reason for fanning the wet bulb.

4. Under what kind of weather conditions will the difference between the readings of the two thermometers be greatest? least?

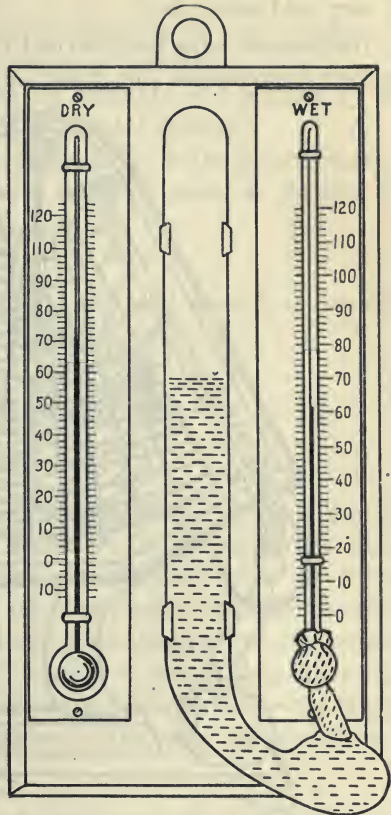

FIG. 68. — A wet and dry bulb hygrometer.

5. How would you expect the thermometer readings to compare if the instrument were placed in an ordinary living room on a very cold winter day?

Instruments have been devised to read humidity directly, such as hair hygrometers and those containing a compound expansion

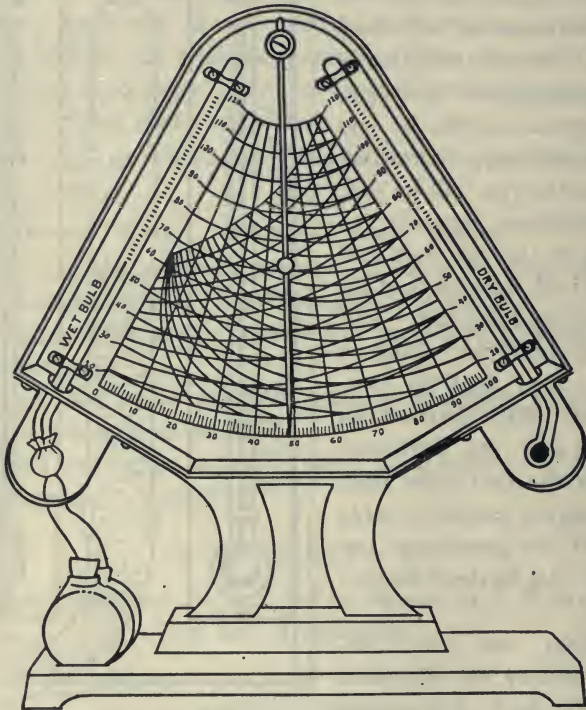

FIG. 69. — The hygrodeik, — a hygrometer containing a dial for indicating the percentage humidity.

element. Many organic materials expand and contract as a result of changes in humidity. They are not considered as reliable as the wet and dry bulb hygrometers, and they require occasional adjustment for accurate results.

**B. Reference Work.***a. General Science* — Barber.

6. What is the average relative humidity of your locality in the months of June, July, and August? See map.

7. What is the average relative humidity of your locality in the months of December, January, and February?

8. Where is the region of lowest humidity in the United States?

9. How does moisture in the air affect personal comfort in winter and in summer?

*b. Weather* — Jameson.

10. How is humidity related to the feeling of warmth of a room?

11. What is a hygrodiek? Explain briefly.

## 73. PHONOGRAPH — B

MATERIALS. Phonograph; screw driver.

**A. The Tone Arm, the Horn, and the Box.** The tone arm is the pipe which leads from the sound box to the horn. The more recent types of phonographs and graphophones have the horns concealed in the box. Some of the older models had large external horns for amplifying and controlling the direction of the sound. The quality of tones produced depends to some extent upon the size, shape, and material of the resonating wooden box, — the larger cabinet types giving greater richness to the more delicate musical tones.

1. How many motions must the tone arm have? Explain them. The length of the arm must be such that it describes as nearly as possible a straight line across the grooves or threads of the record.

2. How is the volume of tone controlled on this machine?

3. Can you look into the box and see the horn? Of what material is it made?

**B. The Motor.** Ask the instructor to remove the platform and the screws which hold the motor in place. First unscrew the winding crank. Handle the motor with extreme care. The large rotating drum contains the tightly wound steel spring similar to the spring of a clock. This spring furnishes the motive power for driving the mechanism. Set the motor upside down in a convenient position to observe its operation. Turn the starting lever and let it run.

4. How many revolutions are made by the shaft which holds the disk platform while the spring shaft makes one revolution? Count them.

5. How many cog wheels produce this effect?

6. What is the purpose of the ratchet at the side of the drum which operates when the spring is being wound?

7. Observe the governor mechanism (two revolving metal weights). How do these weights prevent the mechanism from running too fast?

8. What is the principle which controls this type of governor?

9. Explain the operation of the friction pads. What part of the mechanism is operated by the worm-gear?

10. What are the important mechanical results which the governor mechanism accomplished?

11. Diagram a reproducer. See Millikan, Gale and Pyle or Household Physics — Butler or Black and Davis.

### C. Reference Work.

*a. General Science* — Hodgdon.

12. Explain briefly how records are made.

13. Of what is the Edison record made?

14. What names are given to the two types of records?

15. Why are large needles objectionable?

A single spoken word may contain from one to two thousand vibrations. Each vibration is faithfully represented by a minute indentation in the record groove.



## 74. PROJECTION LANTERN — B

To study the operation of a carbon-arc projection lantern.

**MATERIALS.** Carbon-arc projection lantern; large rods for ten-ampere arc; ten-ampere rheostat; battery ammeter; lamp socket-board.

*Outlet for 110 volt electric current*

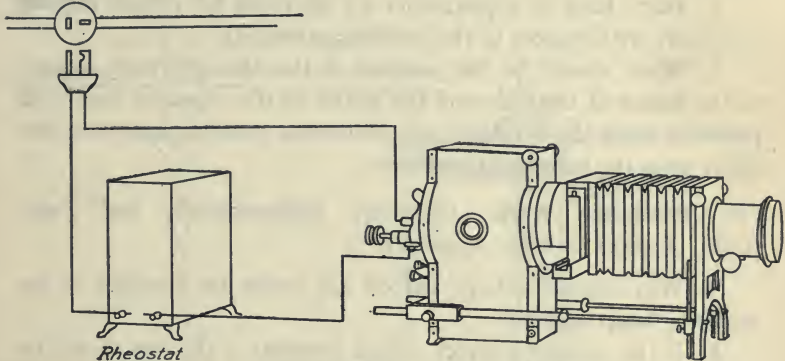

FIG. 70. — Wiring for a carbon-arc projection lantern.

**A. Large Carbon Arc.** Clamp two large projection lantern carbons to two ring stands and use the large ten-ampere rheostat in series as a resistance. Connect one wire from the line terminal plug to one post of the rheostat. From the other post of the rheostat connect a wire to one of the carbon rods on the ring stand. Connect a wire from the other carbon rod to the second line terminal. Before making the attachment to the line ask the instructor to approve your wiring plan.

1. Operate the large carbon arc. Does more current flow when the carbons are touching or when the arc is burning? Explain.

2. If a rheostat lets ten amperes flow on the 110-volt line, what is its resistance in ohms? Apply Ohm's Law: Volts divided by ohms equal amperes.

**B. The Projection Lantern.** Wire the terminals of a projection lantern in series with the ten-ampere rheostat and operate it.

3. With respect to the center of the condensing lenses, how should the arc be placed?

4. Why are projection lantern carbons usually placed at right angles?

5. What kind of adjustments are provided for proper placing of the arc with respect to the condensing lenses?

6. What should be the position of the arc light with respect to the center of the slide and the center of the objective lens? If possible, move the arc light out of correct position and note the effect upon the image on the screen.

**C. Reference Work.** *Electricity Experimentally and Practically Applied* — Ashe, Appendix.

7. Why should a large carbon arc never be attached to an ordinary lamp socket?

8. If the current is direct, which terminal of the line should be attached to the upper carbon? Why?

9. Diagram a feed mechanism and rheostat with knife switch.

10. How far apart should the carbons stand in operation?

11. If the current is direct, which carbon burns faster?

12. What would you expect to happen if no rheostat were used in the circuit?

## 75. RHEOSTAT AND ELECTRICAL RESISTANCE

To make a two-ampere resistance coil for the 110-volt line.

**MATERIALS.** No. 30 nichrome or nickel chromium resistance wire; iron or wooden rod of one-quarter inch diameter for winding coil; projection lantern; large spool; wood frame; rheostat (10 amperes on 110 volts); ammeter.

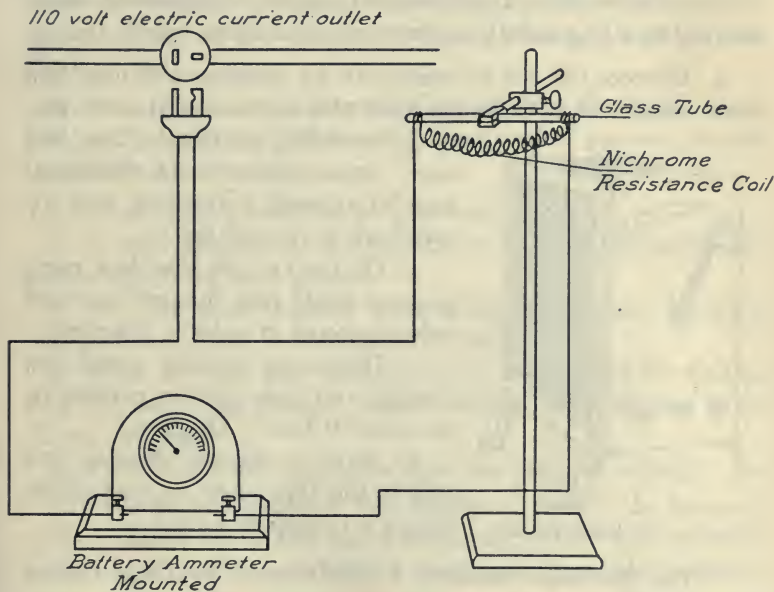

FIG. 71. — A coil of resistance wire with an ammeter in series.

**A. Resistance Wire.** No. 30 nichrome wire has a rated resistance of six and two-tenths ohms per foot. By Ohm's Law (volts divided by ohms equal amperes) determine the number of ohms required to let two amperes flow through on the 110-volt line.

1. What length of No. 30 wire gives this amount of resistance? Have your determination of length approved by the instructor.

**B. The Construction.** Measure off this length and rewind it on an empty spool. (*Caution. Keep this wire stretched when off the spool, as it is likely to become badly tangled.*) Fasten the wire firmly at one end of the winding rod. Let your associate hold the spool while you wind the wire carefully on the rod. Each turn of the wire on the rod should be wound tight against the preceding turn and during the winding the wire should be stretched tight. When the winding is completed allow the coil to release and remove. Suspend this resistance coil on a ring stand from the two ends of a glass rod for testing.

2. Connect the coil in series with an ammeter and note how many amperes it lets through when attached to the 110-volt line.

3. According to Ohm's Law, how many amperes flow would this resistance let through if attached to a 55-volt line? a 220-volt line?

4. On the 110-volt line, how many amperes would pass through two such coils connected in series? Diagram.

5. How many amperes would flow through two such coils in parallel on the 110-volt line? Diagram.

6. Make a diagram showing how coils of this type might be used for obtaining a 10-ampere current.

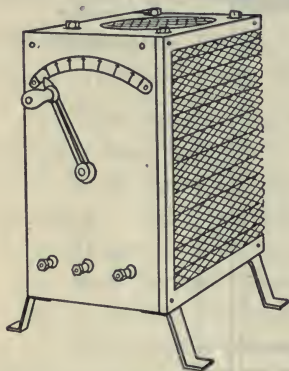

FIG. 72. — A variable rheostat.

**C. The Rheostat.** Examine a large rheostat for the projection lantern. Some rheostats are made variable, for example, 10 to 25 amperes.

7. Indicate by diagram how the coils are arranged.

8. Name two electrical instruments which use a rheostat.

9. What would happen if one of these instruments were attached to the line current without the rheostat? Explain.

10. Name four household utensils which employ resistance wires for generating heat. See Butler's *Household Physics*.

## 76. SEWING MACHINE — B

To study the mechanical operation of a sewing machine.

**MATERIALS.** One or more large sewing machines of the lock-stitch type; screw driver; oil can.

**References**—*General Science*, Barber; *General Science*, Hodgdon; *Singer Manuals*; *Mechanics of the Sewing Machine*; Chart—*Four Distinct Types of the Singer Sewing Machines*, Singer Sewing Machine Co.

**A. The Mechanism.** Remove the belt from the band wheel. Tilt back the machine head on its hinges so that you can observe the mechanism beneath.

1. What make of machine are you studying?

2. Is this machine a chain-stitch or a lock-stitch machine?

Give a reason for your answer.

3. Was the small machine used in Sewing Machine A, Singer No. 20, a lock-stitch or a chain-stitch machine?

4. What are the four common types of machines for making lock stitches? See *General Science*, Barber, or *Mechanics of the Sewing Machine*.

5. To which of the four types does this machine belong?

Remove the face-plate on this machine. Locate the following parts: balance wheel, arm shaft, needle bar, thread take-up lever, presser bar, feed dog, stitch or feed regulator, bobbin holder, shaft or connecting rod which operates the bobbin, feed rock shaft. See *General Science*, Hodgdon.

6. Name four essential moving parts of the machine.

7. Name a single shaft by means of which all of these movements are controlled.

8. The operation of a feed dog must consist of a combination of two motions, horizontal and vertical. How are these motions obtained?

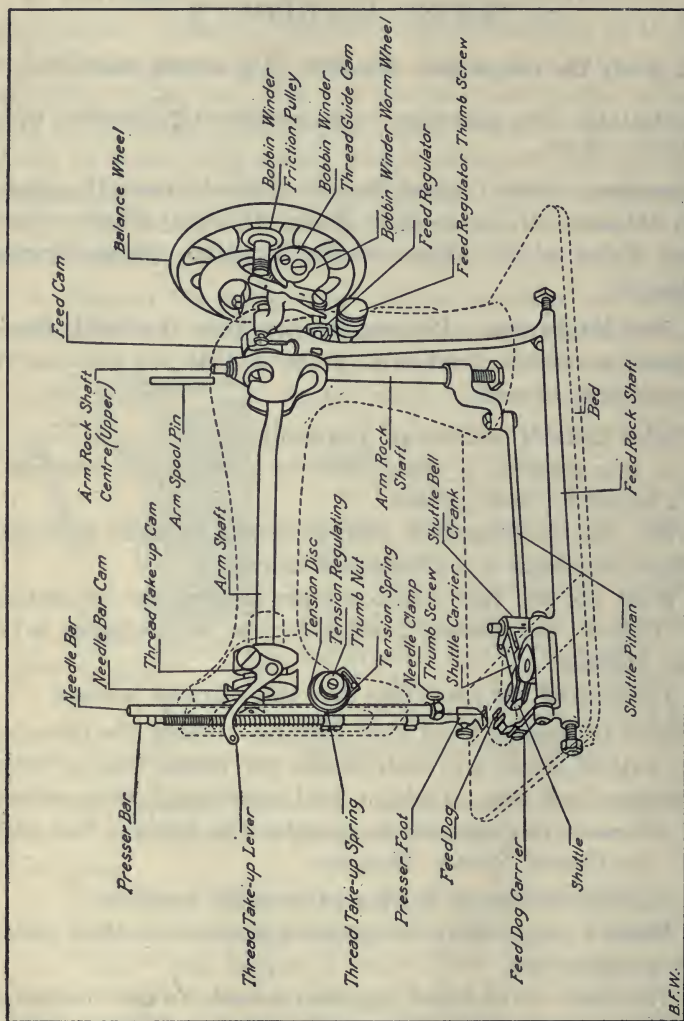

FIG. 73. — The mechanism of a sewing machine — oscillating shuttle type

9. Which of the two motions of the feed dog does the stitch regulator vary?

10. How is the motion of the needle bar accomplished?

11. How is the thread take-up operated?

12. Explain how the arm shaft operates the bobbin holder.

### **B. Types of Stitches.**

13. Diagram a series of stitches made by a chain-stitch machine. See *General Science*, Barber.

14. Diagram a series of stitches made by a lock-stitch machine. For ordinary stitching, the upper and under threads of a lock-stitch seam should be locked midway between the upper and lower surfaces of the material. If the tension on the upper thread is too tight, or if that on the under thread is too loose, the threads will lock on the upper surface.

15. Under what conditions of tension would the thread lock on the under surface of the material?

16. How may the tension of the upper thread be adjusted? of the lower thread?

**C. Oiling.** The importance of frequently oiling machines which involve considerable friction cannot be overestimated. The life of a sewing machine may be doubled by proper attention to this detail. Parts that move most need more frequent oiling.

17. How many holes are provided for oiling the arm shaft?

18. How would you oil the needle-bar mechanism?

19. How many bearings should be oiled underneath the head?

## 77. THE STEAM ENGINE

To operate a steam engine and study its action.

MATERIALS. Boiler; engine; tubing, small demonstration model.

NOTE. The pressure cooker may be fitted with an outlet and stop-cock and used as a substitute for a boiler. To avoid ruining the pressure cooker by boiling it dry, place three quarts of water in it and record the starting time. Do not heat longer than twenty minutes without refilling it.

**A. Filling and Heating the Boiler.** Examine the tubes of the boiler before heating it. (*Caution. Never build a fire under a boiler unless you have water in it, otherwise the boiler may be ruined. In operating, never allow the water-level to drop as low as the bottom of the water gauge. In this experiment do not let the pressure gauge rise above thirty pounds per square inch.*) The principal parts of the boiler are: boiler tubes, firebox, ash pit, grates, water gauge, steam gauge, and safety valve.

Fill the boiler three-fourths full and heat by means of the gas-burner in the firebox. Turn gas on full. Before starting the engine, oil all bearings.

1. What automatic protection have boilers against accumulating an excessively high pressure?

2. When the pressure gauge of a boiler registers 100 lbs. per square inch, how hot is the water in the boiler? Refer to a table of pressures and temperatures. See Barber's *General Science*.

3. At what temperature does water boil under 75 lbs. per square inch gauge pressure?

In the boiler of a locomotive the pressure is about 200 lbs. per square inch, and the boiling point is about  $390^{\circ}$  F. On the top of Mt. Blanc, three and one-half miles above sea level, the pressure is about  $7\frac{1}{2}$  lbs. lower than the pressure at sea level, and the boiling point is  $185^{\circ}$  F.

4. Draw a section of an upright (fire tube) boiler. See Barber's *General Science*.



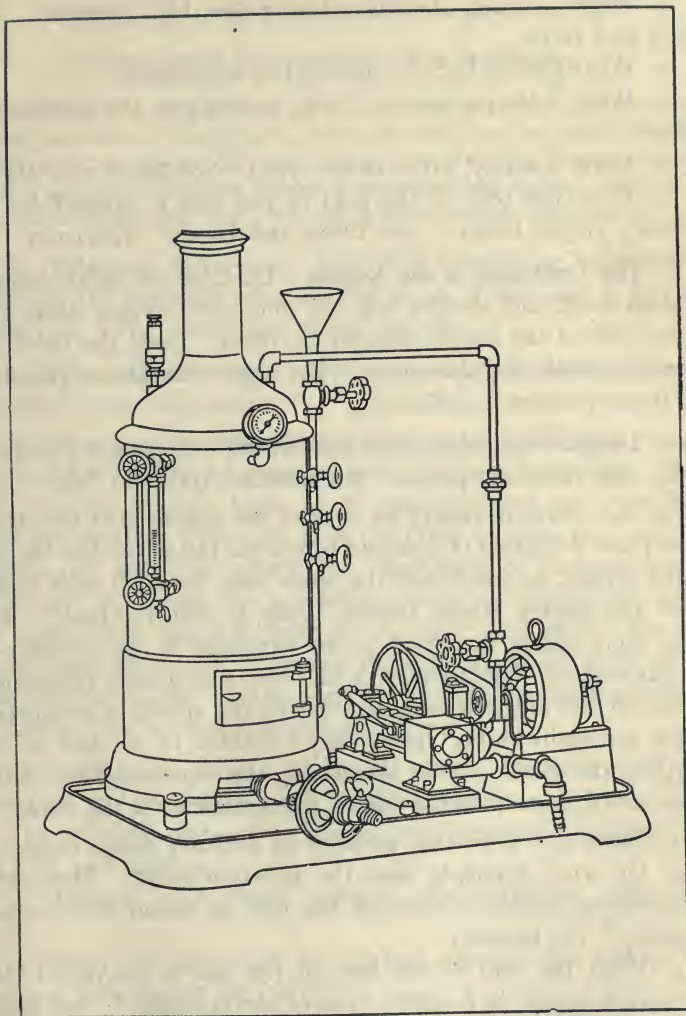

FIG. 74. — A boiler and steam engine.

5. Draw a section of a water tube boiler (high pressure). See Black and Davis.

6. What kind of boiler is used in this experiment?

7. What is the purpose of a thick covering on the outside of a boiler?

8. Draw a safety valve (lever type). See Black and Davis.

9. What per cent of the heat of the coal is utilized by an ordinary engine boiler? See Black and Davis — Efficiency.

**B. The Operation of the Engine.** Examine the small demonstration model and observe how the slide valve directs steam first to one side of the piston, then to the other. Open the valve between the boiler and the engine. The engine should run, provided the steam pressure is sufficient.

10. Diagram the steam-chest and cylinder, showing the position of the slide valve and piston. See Millikan, Gale and Pyle.

The slide valve is usually set so that the admission of the steam takes place a fraction of a second before the piston reaches the end of the stroke, in order that the space may be filled with steam when the return stroke begins. This is called "lead." The same thing occurs in regard to the explosion in the cylinder of the gas engine. Furthermore, it has been found more economical to cut off the entrance of steam before the stroke is completed. Steam ordinarily enters during only one-third to one-half of the length of the stroke. After the cut-off, the expansive force of the steam exerts some pressure during the remainder of the stroke.

11. Name five important parts of an ordinary steam engine.

12. On what principle does the governor work? How does the governor gradually shut off the flow of steam as its speed increases? See Hoadley.

13. What per cent of the heat of the coal is converted into mechanical energy in a simple type of steam engine? See Black and Davis — Efficiency.

14. Outline a brief history of the steam engine. See Barber.

## 78. TELEPHONE — A

## To study the operation of a telephone.

**MATERIALS.** Three telephone receivers, one to be opened; two microphone transmitters; two dry cells; wires extending from one room to another; clock; two thin copper plates about an inch and a half in diameter; bottle of carbon granules, made from a crushed projection lamp carbon. (Part of the apparatus for this experiment must be obtained from the instructor.)

**A. Telephone Receivers.** Test each receiver by touching the wires to the terminals of a dry cell to see if they are in working condition. The diaphragm should sound.

1. What happens to the diaphragm when the battery current passes through the receiver?

Attach one of the receiving instruments to the binding posts at each end of the line by means of wires (without batteries). Make all wire connections tight. Let your associate say "Hello!" into one receiver while you hold the other to your ear, and vice versa. By speaking against the diaphragm of one instrument, causing it to vibrate, you generated minute electrical pulses which in turn pulled the diaphragm at the other end of the line and reproduced the sound. Unscrew the cover from the large end of the receiver labeled "To be opened," and observe the mechanism. (*Caution. Do not break the delicate wires.*)

2. Diagram a simple telephone system consisting of two receivers and two wires. See Millikan, Gale and Pyle.

The principal parts of a receiver are: permanent magnet, coil of wire, and diaphragm.

3. Diagram a typical receiver. See Millikan, Gale and Pyle.

4. When the diaphragm is touched against the end of the magnet, why does it not fall off?

5. When the diaphragm is in position it should not quite touch the end of the magnet. What happens to this diaphragm

when you speak against it? When the instrument is used in this way it is a generator of minute electric current pulses.

6. Why is it incorrect to say that the sound passes over the wires? What does pass over the wires?

7. Explain what happens at the other receiver if you tap the diaphragm slightly with the point of a pencil.

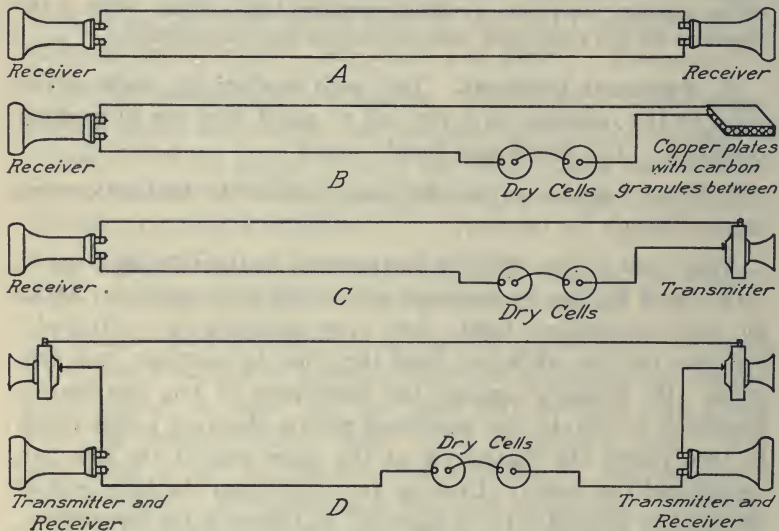

FIG. 75. — Wiring for the study of telephone transmitters and receivers.

**B. The Microphone Transmitter.** The first telephones used two receivers as above, with batteries, but they were not satisfactory for very great distances because the current pulses are so small. The microphone has aided in making longer distance telephoning possible because it causes pulses of greater magnitude. The use of the induction coil will be studied in Telephone — B.

Make a microphone transmitter as follows: Attach one terminal of the dry cells to a copper plate and the other terminal to the line. Attach the other copper plate to the second terminal of the line. Place a half dozen small granules of carbon on the one plate

and carefully lay the other copper plate on the carbon granules so that the granules completely separate the two plates. Attach a receiver at the other end of the line.

8. Touch the upper plate with the end of a strip of paper. This touch should be audible in the receiver at the other end of the line. Explain.

9. Place an alarm clock in a horizontal position, face up, under the plates, so that the plates with carbon granules rest upon the clock. You should hear the clock tick in the receiver at the other end of the line. Explain.

10. Attach the microphone transmitter and two dry cells at one end and a receiver at the other. Stand the microphone transmitter on a clock, or speak into it. Can you use the microphone transmitter as a receiver? Explain.

11. Connect a transmitter and a receiver in series at one end, and a transmitter, a receiver, and two dry cells in series at the other end. Speak through this system. Diagram it.

## 79. TELEPHONE — B

### To study the operation of a two-party telephone.

**MATERIALS.** Two telephone outfits; magneto generator; screw driver. (Part of the apparatus for this experiment must be obtained from the instructor.)

**A. Attaching the Telephones.** Two telephone outfits will be found in the cabinet. Attach them to the hooks at the terminals of the laboratory telephone lines. The two terminals at the top of each telephone are to be connected by wires to the terminals of the line. The two terminals at the bottom of each instrument should be connected to a set of two dry cells. Make all wires tight to insure contact.

1. Diagram a simple local battery telephone system with primary and secondary circuits, including receivers, transmitters, batteries, and induction coils. See Millikan, Gale and Pyle.

**B. The Induction Coil.** For longer distances it is necessary to use, in addition to the microphone transmitter, an induction coil. This is a small iron bar surrounded by two separate coils, one of few turns and one of several hundred turns. It is a small transformer. The transmitter current pulses go through the coil of few turns and back to the dry cells and transmitter. The coil of

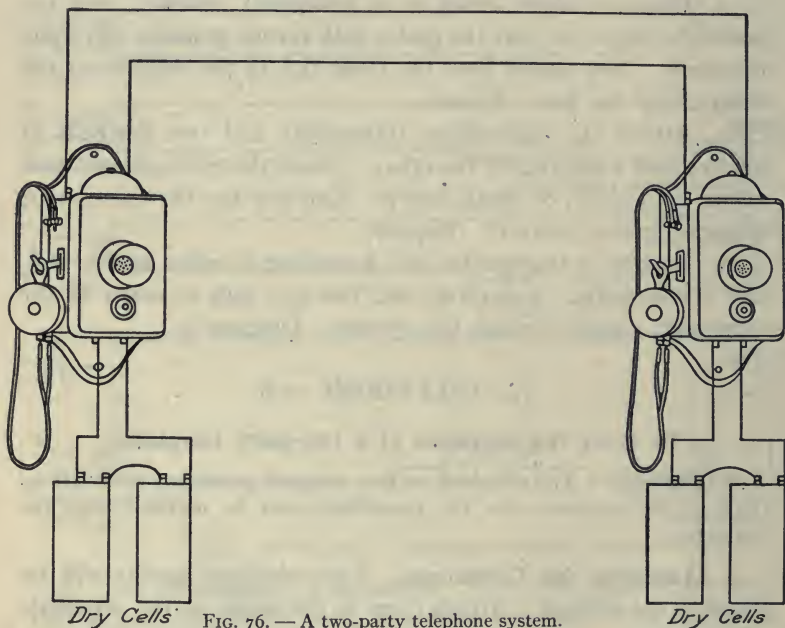

FIG. 76. — A two-party telephone system.

many turns changes the three-volt current of the transmitter circuit to a higher voltage current for long distance.

**C. The Magneto Generator.** Attach a magneto generator and use it to ring up the other party.

**D. Study of the Wiring Circuits.**

2. Make a careful diagram of the wiring of the telephone as shown in the illustration. Note that a dotted line and a full line

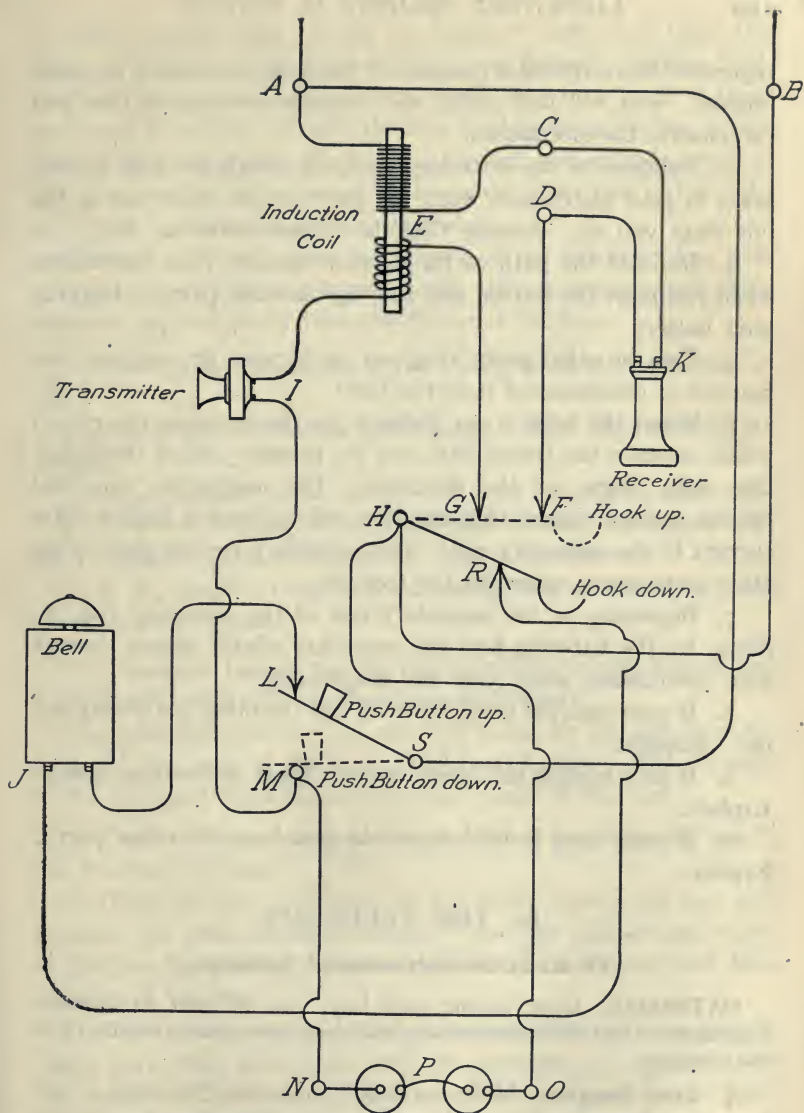

FIG. 77. — Wiring diagram for a two-party telephone instrument.

represent the two possible positions of the hook, and also of the push button. You will find one of the instruments open so that you can observe the mechanism.

3. Indicate by the lettering, the path which the bell current takes in your instrument when the party at the other end of the line rings you up. Assume that the current enters at *B*.

4. Indicate the path of the current through your instrument when you push the button and ring up the other party. Begin at your battery.

5. Can the other party ring you up if your dry cells are exhausted or disconnected from the line?

6. When the hook is up, indicate by the lettering the circuit which operates the transmitter and the primary coil of the induction coil. Begin at the dry cells. The magnetism produced by the current pulses through this coil induces a high voltage current in the secondary coil. This secondary current goes to the other instrument, operating the receiver.

7. Beginning at the secondary coil of the induction coil, indicate by the lettering how the secondary circuit passes through your instrument when you are telephoning.

8. If your receiver is off the hook can the other party ring you up? Explain.

9. If your hook is held down can you speak to the other party? Explain.

10. If your hook is held down can you hear the other party? Explain.

## 80. THE TELESCOPE

### To study the astronomical telescope.

**MATERIALS.** Large reading glass lens; lens of short focal length; ring stands. (Part of the apparatus for this experiment must be obtained from the instructor.)

**A. Lens Images.** Make a careful preliminary drawing of the image of a gas flame as it is produced on a cardboard screen by



a simple convex lens. Trace the paths of light rays from two different points on the flame as they pass through the lens to illuminate the screen. Follow three light rays from each of these points on the object through the lens to their focus on the screen. One of each three rays should pass through the optical center of the lens, and the other two should pass on either side of the optical center. Have this drawing approved.

(*Caution. Do not touch the surface of an expensive lens with your fingers, or with any other object.*) In making measurements measure approximately from the center of the lens.

1. Under what conditions is the image equal to the object in size?
2. Under what conditions is the image smaller than the object? Larger?
3. As an image is made larger, how is its brightness affected?
4. How do the sizes of the object and the image compare with their distances from the optical center of the lens?
5. If the image is twice as far from the lens as the object, how do their sizes compare?

**B. Telescope Lenses** may be represented by a large lens of long focal length and a small lens of short focal length.

The principal focus is the point of focus for parallel rays, for example, the rays of the sun. The focal length is the distance of the principal focus from the optical center of the lens.

6. Find the focal length of the two telescope lenses by one of the following methods:

*a.* Hold the lens in the path of the direct rays of the sun, and measure the focal distance directly. Use only the central region of the lens by holding a piece of cardboard with a one-inch hole in front of the lens.

*b.* Focus the lens on a distant object (500 feet or more away). Light rays from this object will be approximately parallel and the image of the distant object may be considered at the prin-

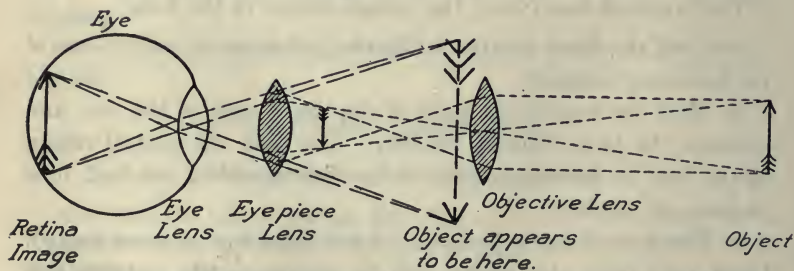
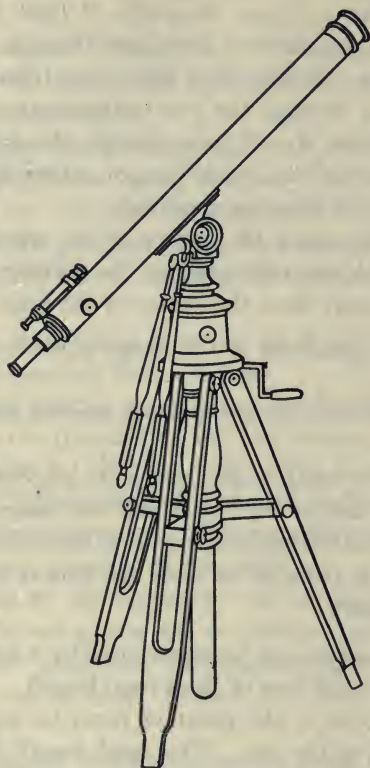

FIG. 78. — A telescope with diagram showing how the light rays are refracted, producing an enlarged image on the retina.

principal focus. When the object is in sharpest focus, measure the distance from the optical center.

**C. The Astronomical Telescope.** In the astronomical telescope the degree of enlargement depends upon the power of the eyepiece and the focal length of the objective. An objective with a long focal length gives a larger image than one with a short focal length. The size of a lens image is proportional to its focal length. An objective of large diameter is preferable to a small one because it collects more light from the object, and thereby makes a more brilliant image. The more brilliant the image, the higher it may be magnified by the eyepiece.

Set the large objective lens in position at one end of the laboratory, and, with a cardboard screen behind it, get the image of a window located at the other end of the room.

7. What is the distance of this image from the center of the lens?

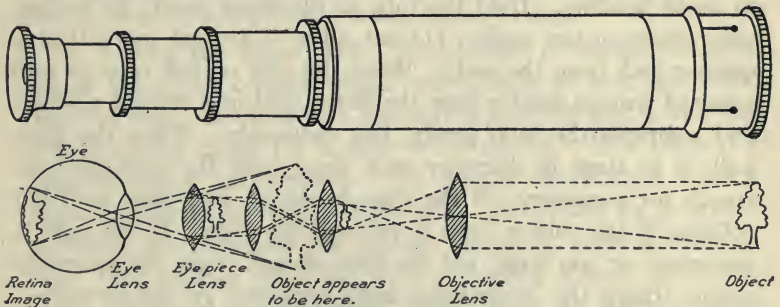

FIG. 79. — A terrestrial telescope. The two lenses between the objective and the eyepiece cause the object to appear upright.

Now remove the card and bring the eyepiece lens into position near the point of focus. Look into the eyepiece and you should be able to see the image enlarged.

8. Should the eyepiece be nearer the objective lens than the image in question 7, or farther away?

9. Make a careful diagram of the path of light rays from the object through both lenses of the telescope.

## 81. THE THERMOMETER

## To make a thermometer.

**MATERIALS.** Thermometer tubing — one millimeter bore; atomizer bulb; kerosene in small bottle; two Bunsen burners giving sufficient heat to readily melt glass tube; beaker and stand for boiling water; glass funnel and rubber connection.

**A. Making Thermometer Bulbs.** Adjust the Bunsen burner so that it gives the maximum heat (colorless or blue flame). The Bunsen burner should be of large size. Have the Bunsen flame inspected by the instructor before proceeding further. As a preliminary exercise attach an atomizer bulb to one end of a piece of ordinary laboratory glass tubing (large bore of three or four millimeters diameter), and heat the other end in the flame till it softens and seals. (NOTE. Keep revolving the tube in the flame to avoid bending. Hold the tube in the flame steady by resting your elbow on the table. Do not allow it to seal more than a quarter inch from the end.) When the end of the tube is well softened remove quickly from the flame, hold in a vertical position and compress the bulb firmly, but cautiously. When the glass bulb is as large in diameter as a dime, hold the atomizer bulb steady for a moment till the glass hardens. The glass bulb will collapse if the rubber bulb is released too soon. If the bulb is imperfect, or too large, cut the tube off and begin the operation again. Have the preliminary bulb approved by the instructor. He will then give you a piece of thermometer tubing.

**B.** Attach the atomizer bulb to the piece of small bore thermometer tubing. Make connections air tight by wrapping with heavy thread. Proceed as before and make a bulb as large in diameter as a dime. (*Caution. Heat gently at first to avoid cracking the thick wall tubing.*)

**C. Filling the Thermometer with Expansion Liquid.** First remove the rubber bulb and attach a funnel by means of a short,

rubber-tube connection. Pour into the neck of the funnel just enough kerosene to fill the thermometer. With liquid in the funnel hold the empty bulb near a flame (not in the flame) till it becomes warm. Allow it to cool and as the heated air in the bulb contracts, liquid will pass into the bulb, filling it perhaps one-fourth full. Now heat this liquid in the bulb cautiously till it begins to boil. This boiling drives out the remaining air and on cooling it will fill completely. When it is completely filled, place the thermometer with funnel attached in a beaker of boiling water. When the liquid in the thermometer reaches the temperature of boiling water, the funnel may be removed. (*Caution. Pour excess kerosene carefully into an evaporating dish.*) A bubble may be removed from the bulb by tapping with the finger so that it rises to the top in small bubbles, or by shaking up and down very forcefully.

NOTE. The kerosene may be dyed red with an oil soluble dye. This involves danger of soiling clothing in case the bulb breaks.

**D. Sealing the Upper End.** In a beaker of boiling water the top of the liquid column should stand about an inch and a half from the end. If the liquid rises to the extreme top, hold it cautiously over a flame till a drop is forced out. Now place it in water at faucet temperature. The column should then stand at about one-third the height of the tube. If cracked ice or snow is available, observe where the column stands at freezing temperature. For sealing, place the bulb in boiling water. In boiling water the liquid column should stand about an inch and a half from the top. Holding a Bunsen burner in your hand, heat the end of the thermometer (heat gently at first) till it seals. Turn it while sealing to prevent bending. If bubbles reappear in the bulb when it contracts, they may be removed as suggested above. This thermometer should be mounted on a board, or card, on which a scale has been marked by comparison with a correct thermometer. In this form it may be used as a room thermometer. Mark the boiling point with a file when the bulb is

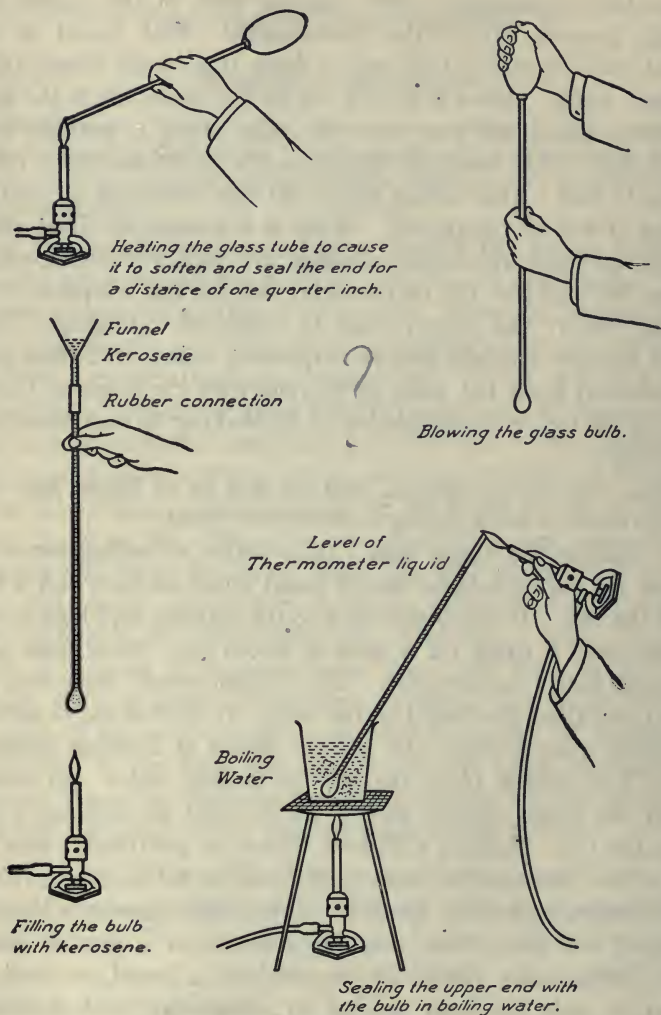

FIG. 80. — Making a thermometer.

held in a beaker of boiling water. Mark the freezing point when the bulb stands in melting ice or snow.

1. Why should a thermometer be sealed when the liquid is at the top?

2. Glass expands at a slower rate than kerosene. If they expanded at the same rate, what would be the result?

3. Why are thermometers made with cylindrical bulbs instead of spherical ones? Which form of bulb has the greater surface?

4. How is expansion utilized in the filling of the thermometer?

5. How is vaporization utilized in the filling of the thermometer?

6. How is atmospheric pressure utilized in the filling of the thermometer?

7. Why does a bubble of air in the column become larger when the upper end is sealed and the thermometer cools?

*E. A Mercury Thermometer* may be made in a similar manner. Mercury is the best liquid for registering high temperatures because it has a high boiling point,  $357^{\circ}$  C. or  $675^{\circ}$  F. The freezing point of mercury is  $-39^{\circ}$  C. Alcohol is best for low temperatures because it freezes at  $-130^{\circ}$  C. Mercury affords the largest range on both sides of the ordinary temperatures.

#### *F. References.*

*a. General Science* — Hodgdon.

8. Diagram the three types of thermometer scales indicating the temperatures of melting ice and of boiling water.

9. What are the temperatures of the following in Fahrenheit and Centigrade: the sun, an arc lamp, melting tungsten, melting cast iron, melting aluminum, liquid air, lowest temperature reached?

10. What are the temperatures of the following: baking bread, pasteurizing milk, high fever, normal body, incubator, room temperature, household refrigerator, danger of frost?

*b. Weather* — Jameson.

11. Explain briefly what is meant by maximum thermometer, minimum thermometer, clinical thermometer.

## 82. THE VACUUM CLEANER

## Centrifugal Fan Type.

To study the construction of a vacuum cleaner and measure its suction, fan speed, and current consumption.

**MATERIALS.** Vacuum cleaner; rubber stoppers; tubing; U-tube; water gauge; speed indicator; rule; ammeter; rug; 30-lb. spring balance; screw driver. (Part of the apparatus for this experiment must be obtained from the instructor.)

**A. Construction.** This vacuum cleaner operates by means of a centrifugal fan attached to a high-speed electric motor. Observe the following parts: cleaning tool, fan housing, motor housing, fan outlet, and bag. With a screw driver open the fan housing. (*Caution. Handle the apparatus very carefully, especially in taking apart. Screws and threads may be easily ruined. Do not lose the parts.*)

1. What is the diameter of the fan?
2. How many vanes has the fan?
3. What is the width of the vanes?
4. Are the vanes straight or curved?
5. Measure the length and width of the cleaning tool opening in inches.
6. Measure the inside diameter of the outlet from the fan at the point where it attaches to the bag.
7. How many places for oiling has this apparatus? The life of a high-speed motor may be reduced one-half by failure to properly oil the bearings. Unless the bearings are provided with special oil cups, they should be oiled each time the machine is used.
8. Is the motor shaft in vertical or horizontal position? Horizontal is preferable because the weight then rests on two bearings instead of one.



9. Of what material are the fan and motor housing made? What are some advantages of aluminum?

10. What does the entire machine weigh in pounds? What are some disadvantages of large, heavy machines?

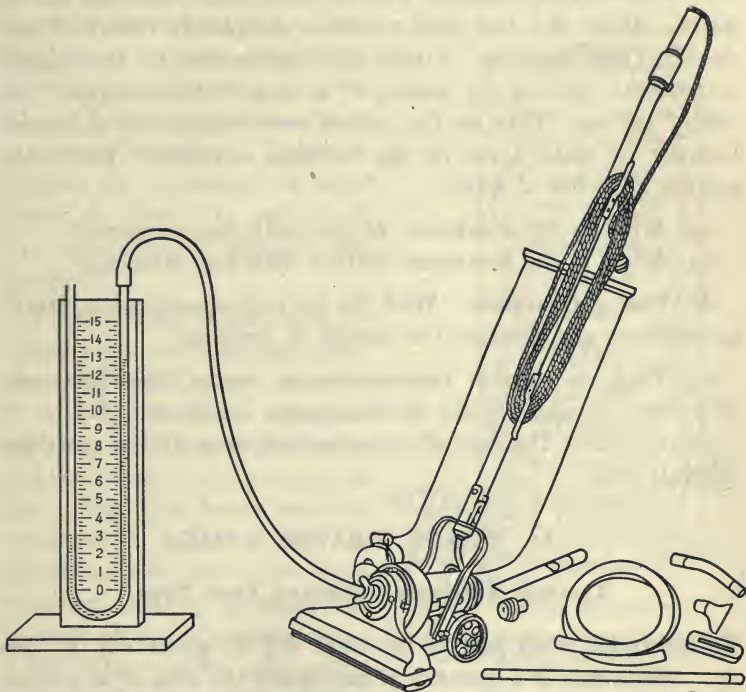

FIG. 81. — A vacuum cleaner with manometer attached for measuring its suction in inches of water column.

**B. Speed of the Fan.** (Do not make this determination without the assistance of the instructor.) The machine should be placed on the rug in actual working condition. The speed indicator is held firmly against the end of the motor shaft. Count the number of revolutions of the dial in fifteen seconds and calculate the rate per minute.

11. How many revolutions does the motor make while the dial of the speed indicator makes one revolution (gear ratio)?

12. Record the speed of the fan per minute.

**C. Test of Fan Suction.** Fill the manometer tube half full of water. Make this test with all inlets completely closed. Close cleaning tool opening. Attach the manometer to the special attachment opening by means of a large rubber stopper and rubber tubing. Turn on the current and measure the difference between the water levels on the two sides in inches. This is the suction in inches of water.

13. What is the maximum suction with bag removed?

14. What is the maximum suction with bag attached?

**D. Cost of Operation.** With the instructor's assistance, attach an ammeter and measure the current in amperes.

15. Find the current consumption in watts. See line voltmeter for voltage. (Volts times amperes equal watts.)

16. Calculate the cost of operation per hour at ten cents per kilowatt hour.

### 83. WATER HEATER — GAS

#### Thermal Efficiency. Kitchen Tank Type.

To determine what part of the total B.T.U. given out by the combustion of a quantity of gas enters the coils of a kitchen tank water heater in heating water from faucet temperature to  $110^{\circ}$  Fahrenheit.

**MATERIALS.** Gas meter; water heater; two two-hole rubber stoppers to fit water inlet and outlet of the water heater; two Fahrenheit thermometers, one in each of the two stoppers; rubber tubing; short glass tubes for connections at stoppers; screw clamps; faucet stopper; gallon measure.

**A. Attaching the Water Heater.** Connect a tube from the gas cock to the inlet side of the gas meter. Connect a tube contain-

ing a screw clamp from the outlet side of the meter to the water heater. (*Caution. Allow a quarter of a cubic foot of gas to flow through the meter before lighting.*) Attach the water tube to the faucet by means of the rubber tube attachment and send the water through the heater coil—from the bottom upward. Record the entering temperature. (*Caution. Do not heat the coil when no water is flowing through it. Before beginning the experiment the water should be allowed to run till its temperature becomes approximately constant.*)

**B. The Test.** When the faucet temperature becomes nearly constant, light the burner and turn it on full. (*Caution. Avoid an explosion by holding a lighted match over the burner before turning on the gas.*) Adjust the flow of water by means of the faucet so that the temperature of the outlet thermometer remains as nearly as possible at  $110^{\circ}$  (temperature of a hot bath). When this condition of adjustment is reached, place a gallon measure under the outlet pipe, at the same time beginning the meter readings. When one gallon of water has passed through the heater, note on the gas meter how many cubic feet of gas were consumed. Record thermometer readings on both sides of the heater each minute of the experiment. Average the readings for each thermometer. The B.T.U. taken up by the water in passing through the coils is found by multiplying the amount of water in pounds heated by the difference in temperature on the two thermometers. One

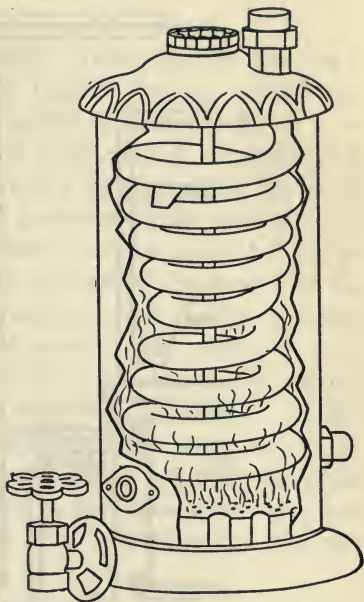

FIG. 82.—A sectional view of a gas water-heater showing the heating coil.

gallon measure under the outlet pipe, at the same time beginning the meter readings. When one gallon of water has passed through the heater, note on the gas meter how many cubic feet of gas were consumed. Record thermometer readings on both sides of the heater each minute of the experiment. Average the readings for each thermometer. The B.T.U. taken up by the water in passing through the coils is found by multiplying the amount of water in pounds heated by the difference in temperature on the two thermometers. One

gallon of water weighs eight and three-tenths pounds. Make at least two tests and see if they agree.

1. How much heat in B.T.U. did the water receive?
2. How much gas in cubic feet was consumed?

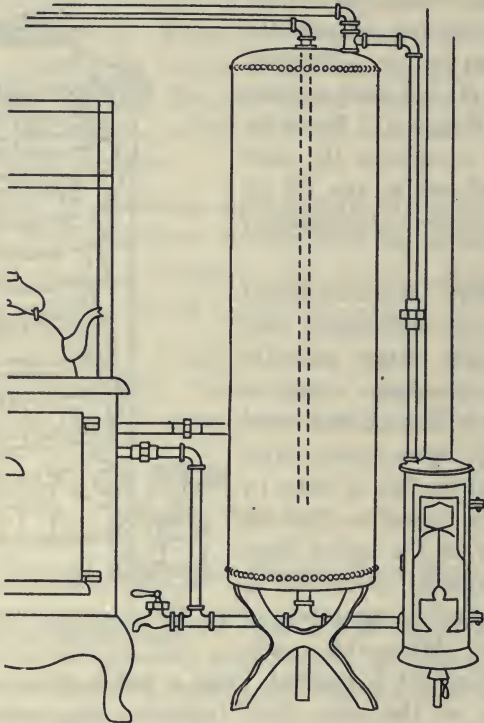

FIG. 83. — A gas water heater attached to a kitchen hot water tank. The kitchen range is also attached to the same tank.

3. How much heat in B.T.U. did this amount of gas represent? (One cubic foot gives out six hundred B.T.U.)
4. What percentage of the total heat produced by the gas did the water receive? Thermal efficiency equals heat received by the water divided by heat of combustion of the gas. (Question 3.)

5. Diagram a gas water heater connected to a kitchen tank. See Butler's *Household Physics*.

6. Diagram a kitchen tank attached to a range. See *Mechanics of the Household* — Keene.

7. What is a waterback?

**Instantaneous Gas Water Heater.** These heaters are made very large for supplying hot water faucets directly without the use of a storage tank. The gas is turned on automatically as a result of opening the faucet. This is accomplished by means of a special mechanism which is operated by the water pressure. When the faucet is closed the gas is automatically shut off. In these heaters a small pilot light burns continuously for the purpose of lighting the burners. On account of its large size an instantaneous automatic heater is expensive but it is at the same time a very convenient and efficient source of hot water.

A hot water tank may be connected to two sources of hot water supply—for example a kitchen range and a gas heater. In this arrangement the gas heater is used when the range is not in operation. It is a common practice to install hot water tanks in the basement and to connect them to the furnace and to a gas heater. The furnace supplies the heat in winter and the gas heater in summer.

## 84. WATER MOTOR — B

### Brake Horse Power and Efficiency.

To determine the horse power of a faucet water motor.

**MATERIALS.** Water motor with Bourdon pressure gauge attached; two spring balances with heavy cord; speed indicator; ring stand for holding balances.

**A. Operating the Motor.** Attach the motor to the faucet, and turn on the water. These motors are made to operate with a comparatively small flow of water under high pressure. For effi-

cient work the pressure should not be less than thirty pounds per square inch. Remove the motor from the faucets and look into the water outlet and observe the wheel. Note the vanes or paddles

which are pushed around by the impact of the stream of water.

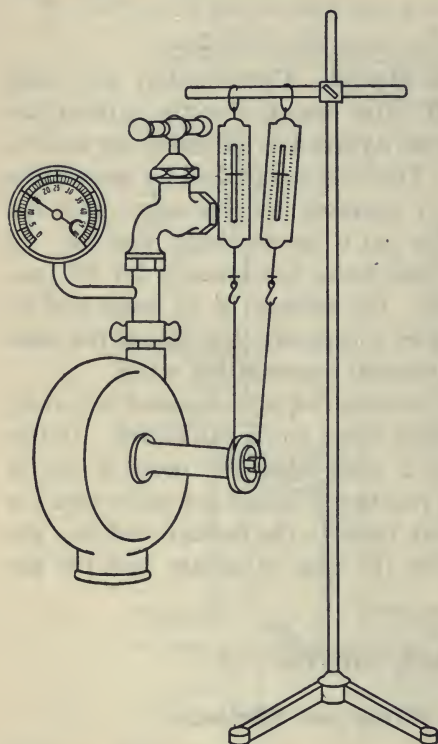

FIG. 84. — Apparatus for measuring the horse power of a water motor.

of the motor-shaft. Hold the indicator firmly enough to prevent slipping, but not so firmly as to reduce the speed.

3. With the second hand of a clock, count the number of revolutions per minute when the motor is running without load.

Suspend two spring-balances from a ring stand as shown in the

1. Attach the motor to the faucet and measure the water pressure, when the motor is running.

2. What height of water column in feet is required to produce this pressure per square inch? (A water column two and three-tenths feet high exerts a pressure of one pound per square inch.)

**B. The Power of the Water Motor.** Operate the water motor, and with a speed indicator held against the end of the motor-shaft, measure the number of revolutions per minute. One revolution of the indicator dial equals one hundred revolutions

diagram, with heavy cord passing around the water-motor pulley. Note that the speed of the motor decreases as the tension of the balances is increased, producing greater friction on the motor pulley. If the tension is increased enough, the motor will be completely stalled. Note that as friction is applied by increasing the tension on the balances as the motor runs, one balance will be pulled more than the other. The pull exerted by the motor is the difference between the readings on the two balances.

4. Make at least five measurements of the pounds pull and the speed per minute, beginning with a very slight pull and increasing with each measurement so that the last measurement is made with enough tension to cause the motor to run at a comparatively slow speed. Multiply the pull in each case by the corresponding speed per minute. One of the products should represent the maximum. If the last product is the greatest, you have not made the tension great enough, and more readings should be taken. In a series of five products the third or fourth should be greatest. Make a table showing the data for these five or more measurements.

5. From the pounds pull and the revolutions per minute of the maximum, calculate the work done per minute. (Pounds times circumference of pulley in feet times speed per minute.)

6. From the result in question 5, what is the maximum horse power of this motor? (Foot pounds per minute divided by 33,000.)

7. Refer to Water Motor—A, and calculate the efficiency of this motor. (Efficiency equals horse power output divided by calculated horse power input, or work out divided by work in.)

## 85. WIRELESS — A

## (Simple Outfit)

To construct and operate a simple wireless sending and receiving system.

**MATERIALS.** *The Sending Apparatus.* Copper sending aerial wire reaching from one side of the room to the other; induction coil; four dry cells; telegraph transmitter; connecting wires. (Part of the apparatus for this experiment must be obtained from the instructor.)

*The Receiving Apparatus.* Copper receiving aerial wire of same length as the sending aerial; simple crystal detector; 1000 ohm telephone receiver.

**NOTE.** You will find a sending aerial wire suspended across one end of the laboratory. The receiving aerial is similarly located at the opposite end of the room. Connect the receiving apparatus at one end and the sending apparatus at the other.

**A. Sending Instrument, — Induction Coil.** (*Caution. Keep away from the secondary terminals of an induction coil when it is connected to a battery, as the secondary current is dangerous.*) First set up the induction coil at the sending end. Before attaching the dry cells connect a short wire to one of the secondary terminals of the induction coil and bend it into position so that it stands about one-quarter inch from the other secondary terminal. Connect four dry cells to the primary circuit, including in the circuit a telegraph key for making and breaking the flow of current into the induction coil. Now operate the induction coil by means of the telegraph key and note the high voltage discharge across the quarter-inch spark-gap. A single spark consists of many oscillations vibrating at the rate of about a million per second back and forth across this quarter-inch gap. Now connect a wire between one end of the aerial and one of the secondary posts of the induction coil. From the other secondary post of the induction coil, lead a wire to the ground by attaching it to a gas pipe or water pipe. This completes a simple sending instrument.



1. Diagram a simple sending instrument. See Black and Davis.

2. Diagram an induction coil. See Millikan, Gale and Pyle or Carhart and Chute.

3. Of what material is the core made?

4. What causes the vibrator or interrupter to move toward the core?

5. What causes it to come back?

6. What effect has the vibrator upon the current which passes through the primary coil of the induction coil?

7. Of what material is a condenser made?

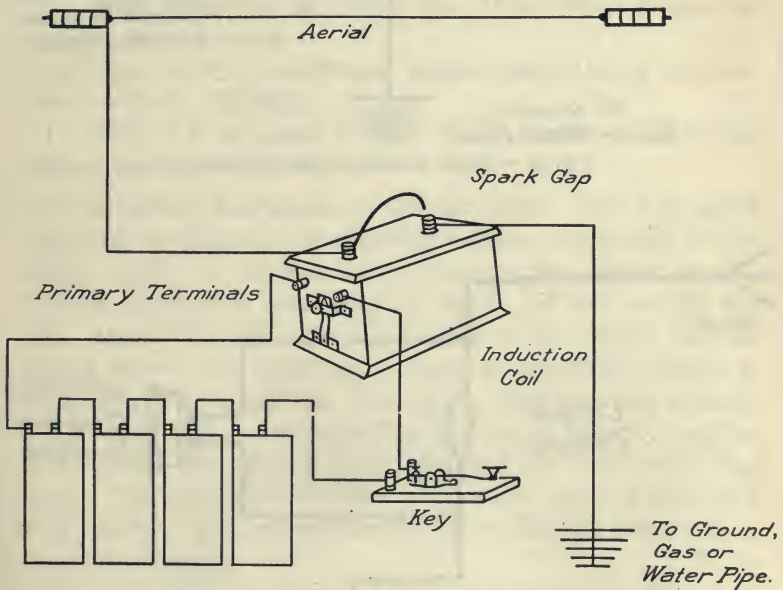

FIG. 85. — Simple wireless sending apparatus.

8. How does the condenser affect the sparking at the vibrator? Otherwise the magnetism of the core would not break quickly and the voltage in the secondary would be much less.

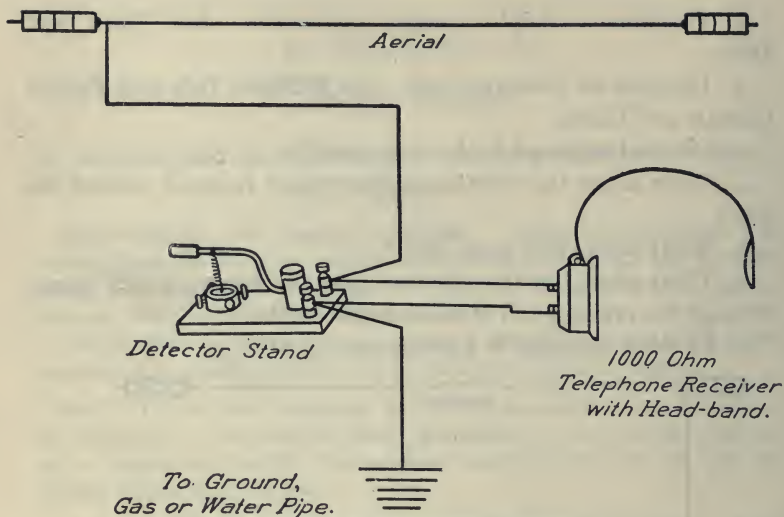

FIG. 86. — Simple wireless receiving apparatus.

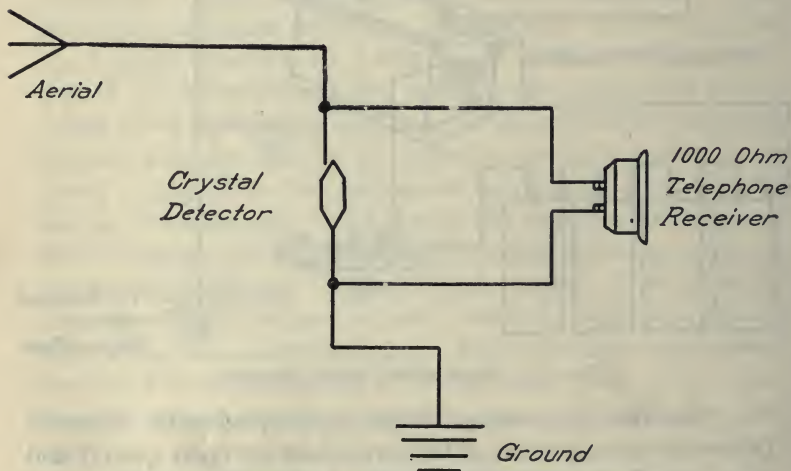

FIG. 87. — Diagram of the detector type of receiving apparatus.

**B. Receiving Instrument, — Crystal Detector Type.** Connect one wire from the aërial to one post of the detector. Connect a second wire from the second post of the detector to the ground, gas pipe or water pipe. Attach the telephone receiver to the same two detector posts. A wireless wave sets up an oscillation between the aërial and the ground, which affects the telephone receiver. Contact at the crystal should be as light as possible. A faint click should be heard in the receiver when a spark sets up an oscillation on the sending wire. The oscillation on the receiving wire is a miniature of the sending oscillation (about a million alternations per second).

9. What effect has the crystal upon these rapidly alternating surges? Refer to texts.

10. Does all of the oscillating current pass through the telephone receiver? Explain.

11. Why is it necessary to have direct current pulses in the telephone receiver?

**C. Receiving Instrument, — Coherer Type.** The instrument first used by Marconi for detecting wireless waves was of the coherer type. See Carhart and Chute, or *The Ontario Physics*. Connect a coherer in series with an electric bell and a single dry cell. Attach the aërial wire to one side of the coherer and the ground wire to the other side. Compress the filings slightly in the coherer, till the bell rings, then tap the glass tube with a pencil, and when the filings are shaken the bell should just stop ringing. Now operate the sending instrument and the bell should ring again. This experiment requires a bell which operates with very little current. The coherer must be set so that the bell is just at the point of ringing.

12. Explain the operation of the coherer in ringing the bell.

**D. Wireless Waves.** The wireless waves are usually from 400 to 9000 feet long. They travel at the speed of light, 186,000 miles per second.

**E. The Detector.** The oscillating surges caused in a receiving aërial by the wireless waves cannot be used to operate a telephone receiver without some means of changing it to a direct current. Certain minerals and crystals permit current to flow through them in one direction more readily than in the other. This gives the effect of a direct current, since the flow in the opposing direction is reduced. Among the materials best suited for this purpose are silicon, galena, and iron pyrites. The crystal is so placed that the aërial current must pass through it on its way to the ground. The telephone receiver is shunted across the detector. Thus the crystal serves as a form of resistance for oscillations in one direction. This tends to send these oscillations across by way of the receiver. By using a tuner and a condenser in connection with the simple detector, it is not difficult to receive messages from distant points. A simple coherer as described in *A* cannot be used for signaling a much greater distance than a mile.

**F. The Aërial Wires.** For a small outfit the aërials ordinarily are from 50 to 150 feet long. They should be suspended as far as possible from any tall objects. Care should be taken to insulate them from other objects.

In order to avoid confusion of signals, laws have been enacted governing the size of sending apparatus for amateurs.

## 86. WIRELESS — B

### To wire and operate sending and receiving apparatus with tuning coils and condensers.

**MATERIALS.** *Sending apparatus:* Aërial; induction coil; sending transformer (helix); condenser, 4 dry cells; key.

*Receiving apparatus:* Aërial; slide tuner; detector; 1000 ohm telephone receiver; fixed condenser; variable condenser; receiving transformer. (Part of the apparatus for this experiment must be obtained from the instructor.)

**A. Wiring Diagrams.** Make careful copies of the wiring diagrams for sending and receiving instruments as found below. Note

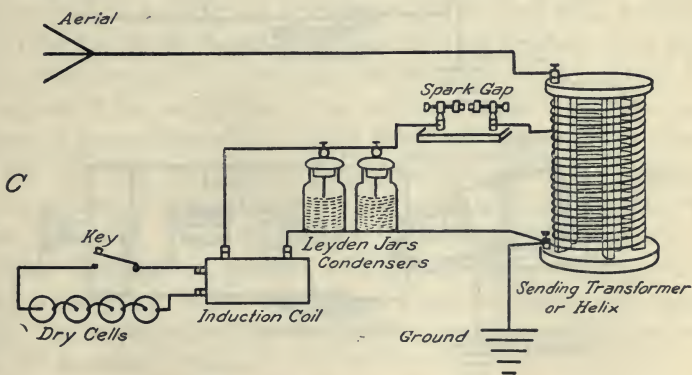
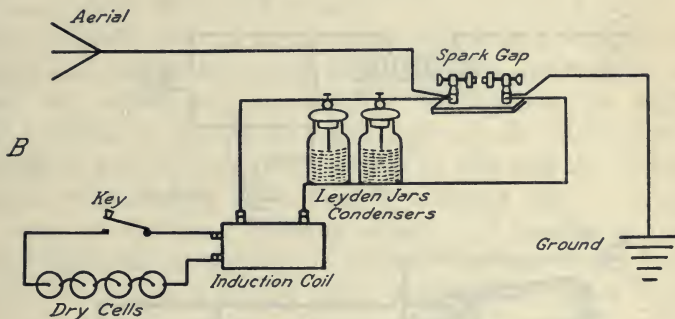
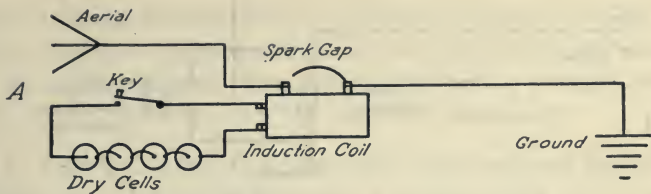

FIG. 88. — Wiring for wireless sending apparatus.

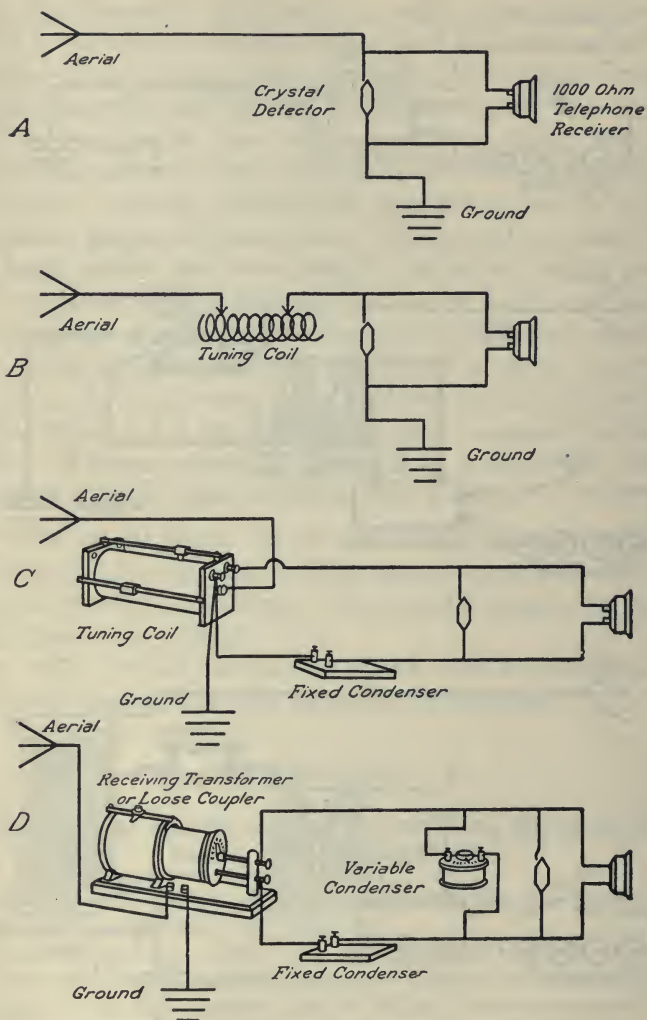

FIG. 89. — Wiring for wireless receiving apparatus.

that the diagrams begin with the simplest wiring and proceed to the more complicated apparatus for selective tuning and greater distance.

Set up the necessary instruments and operate a simple wireless with a crystal detector for the receiving instrument.

**B. Tuning.** If two pianos are in the same room and the dampers raised, when one string is struck a similar string in the second piano will be set in vibration (sympathetic vibration) by the air waves, because this second string is in tune with the first. In the simple wireless outfit, if the receiving aërial is of exactly the same length and size as the sending aërial, they are said to be in tune and they will operate successfully. If, however, the sending aërial should be two hundred feet long, and the receiving aërial should be fifty feet long, they are not in tune and the operation will not be as efficient. In this case by adding a coil of wire called a tuner, to the short receiving aërial, it is possible to make these wires operate similarly to wires of the same actual length. The tuner contains a slide by means of which the number of turns in the coil may be varied. Tuning coils and condensers are used to change the inductance and capacity of oscillating circuits for the purpose of making one circuit oscillate in tune with another. The receiving aërial should be in tune with the sending aërial and the circuit through the telephone receiver and detector should be in tune with the oscillation on the receiving aërial. When a condenser of proper size is used in the secondary circuit of the tuner of the receiving instrument, the oscillations which are induced in the secondary will be made stronger, thus affecting the receiver more intensely. A very common arrangement is to place a variable condenser in parallel with the secondary winding and a fixed condenser in series. In general these condensers are small. Their size is determined by the inductance and capacity required for the secondary circuit.

1. What is the wave length of one of these aërials when used as a simple instrument? (The wave length of a simple aërial is

approximately four times the distance from the spark gap to the end of the wire.)

Make the sending aërial longer by adding the coil of the helix between the spark and the wire leading to the aërial. Make the receiving aërial short by connecting the receiving instrument to its midpoint. Use a simple tuner on the receiving aërial and move the slide into the position which gives the best sound in the telephone receiver. Set up apparatus to correspond with as many of the wiring diagrams as you have time for. If you are in doubt about the wiring ask the instructor.

2. Connect an adjustable condenser or a Leyden jar of proper size in parallel with the spark of the induction coil. What effect does it have upon the loudness of the spark discharge?

3. What effect does the condenser have upon the color of the induction coil spark?

4. What effect upon the operation of the receiving instrument is produced by using a condenser (Leyden jars) on the sending spark?

The sending transformer and the adjustable condenser make it possible to vary the wave length of the sending instrument.

5. What advantage is obtained by changing the sending wave length? See *Wireless Telegraphy* — Morgan.

### C. Reference Work. Carhart and Chute.

6. Make a diagram corresponding to the rapid vibrations of an induction-coil spark. See *Oscillatory Discharge*.

7. Who discovered electric waves? By what other name are they known?

8. Who is recognized as the inventor of wireless telegraphy? Give date.

9. What is the audion detector? Diagram it and state what it does.

10. How much time is required for the passage of a wireless wave between Paris and Washington?



**D. General Information. Laws.** Amateurs are restricted in sending to short wave lengths, and they are limited to comparatively low-power sending apparatus. See Wireless Laws. There is no law regarding the receiving of any messages. It is, however, illegal to divulge information of a private nature.

**Distance.** Buildings, mountains, trees, and especially steel structures, interfere with receiving. Wireless waves travel twice as far over water as over land, and twice as far after sundown as during the day.

There are a number of stations in America having wave-lengths of from twenty-five hundred meters to seven thousand meters. It is now possible to send wireless messages completely around the globe.

By using a simple crystal detector receiving set with a sixty-foot aërial, including tuner and loading coil, it is possible to pick up messages from high power stations more than a thousand miles distant. A simple receiving set is commonly used by amateurs to get the time from the Arlington government station, which has a 2500 meter wave length.

There are over two thousand high-power wireless stations in this country capable of transmitting messages over one thousand miles distance. Many commercial sending instruments operate on wave lengths of from three to six hundred meters.

APPROXIMATE TRANSMITTING DISTANCES OF SPARK COILS FOR SIMPLE  
SENDING AND RECEIVING INSTRUMENTS

$\frac{1}{8}$ inch coil . . .	2 miles	2 inch coil . . . .	16 miles
$\frac{1}{2}$ inch coil . . .	3 miles	3 inch coil . . . .	24 miles
1 inch coil . . .	8 miles	4 inch coil . . . .	32 miles
$1\frac{1}{2}$ inch coil . . .	12 miles		

TABLE OF APPROXIMATE SPARKING DISTANCES

5,000 volts . . .	.22 inch	40,000 volts . . .	2.45 inches
10,000 volts . . .	.47 inch	50,000 volts . . .	3.55 inches
20,000 volts . . .	1.00 inch	100,000 volts . . .	9.60 inches
30,000 volts . . .	1.62 inches	150,000 volts . . .	15.00 inches

## 87. CARBURETOR — A

To study the construction and operation of a carburetor.

**MATERIALS.** Bunsen burner; ignition bottle; large glass jar; one or more sectional carburetors.

**A. Preliminary Work.** The purpose of a carburetor is to mix air and gasoline vapor in the proper proportion to obtain efficient combustion.

Note that a Bunsen burner has two adjustments; one for controlling the gas flow and one for controlling the air flow. The purpose of these adjustments is to mix air and gas in proper proportion before they reach the flame. A Bunsen burner is a carburetor.

1. Close the air inlet completely, and light the burner. The flame is now operating with a "rich mixture,"—insufficient supply of air. Describe the flame under these conditions.

2. Gradually open the air inlet of the burner until sufficient air is admitted to cause the flame to "strike back" to the bottom of the burner tube. Do not permit it to burn for more than a moment at the bottom. Describe the flame when the air inlet is open.

3. Fill the ignition bottle with water and invert it in the jar of water. Allow illuminating gas from a rubber tube to bubble into the bottle, displacing the water. When the bottle is filled with gas, remove it and ignite the gas in the bottle with a match. In the same way remove the bottle when it is half full of gas, allowing air to mix with the gas so that you have a mixture of half gas and half air. Try one-fourth gas and one-fifth gas. Which burns most vigorously or forcefully?

**B. Carburetor Mechanism and Function.** Examine a carburetor in section. The common types of carburetors consist of two main compartments,—the float chamber and the mixing chamber. The purpose of the float chamber is to hold a supply of gasoline from the tank ready for use in the mixing chamber. It must keep this supply at a constant level. The purpose of the

mixing chamber is to provide for mixing a fine spray of gasoline with the air as it is drawn through the carburetor by the suction of the engine. In answering questions refer to *Motor Vehicles — Frazer and Jones — Chapter on Elements of Carburetion.*

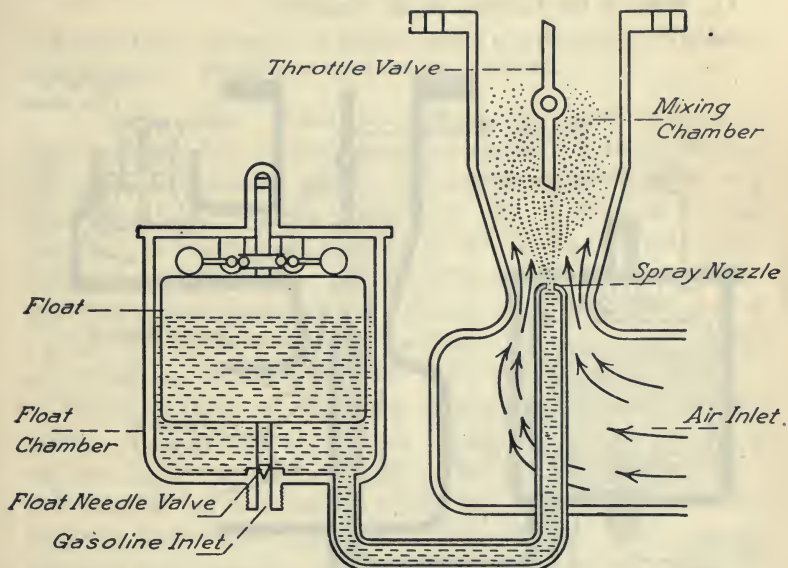

FIG. 90. — Sectional view of a simple form of carburetor, showing float chamber and mixing chamber.

4. What is the purpose of the float?
5. What is the function of the float needle?
6. Of what material is the float made?
7. Explain the sequence of operations which cause gasoline to enter from the tank into the float chamber.
8. Explain what causes gasoline to stop flowing from the tank.
9. What might cause a carburetor to flood (overflow)?
10. What is the function of a spray needle? See fig. 91.
11. If the spray needle is more nearly closed, how is the mixture affected and vice versa?

12. Where is the choker or choke valve located, and what is its function?
13. How is it possible to obtain a richer mixture by means of the choker?
14. What is the function of the throttle?

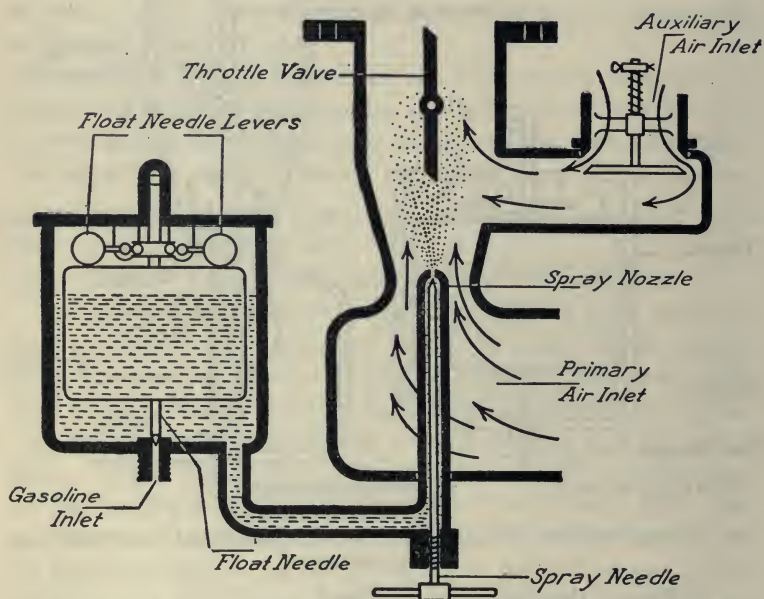

FIG. 91. — Carburetor, showing spray needle and auxiliary air inlet.

15. Why does the mixture tend to become very lean when the throttle is nearly shut?
16. For what purpose is wire gauze used at the entrance to the float needle valve?
17. What is the purpose of the drain-cock at the bottom of the carburetor?
18. What is a Venturi tube?

## 88. CARBURETOR — B

**To study the construction, operation, and adjustments of carburetors.**

**MATERIALS.** A number of different makes of carburetors, — if possible, some in section. Second-hand carburetors may be used.

**A. Carburetion.** When automobiles were first introduced, high-grade gasoline (volatile gasoline) was very cheap. Because the gasoline vaporized readily, carburetors were made in very elementary form — surface carburetors. As the demand for fuel increased, and with it the necessity of including in the fuel some of the heavier distillates, the problem of carburetor design and construction became more complex. Besides changes in the nature of the fuel, the demand arose for carburetors which would provide a more efficient mixture for wider variations in engine speed.

All simple forms of carburetors produce rich mixtures at high speed. If the mixing valve is set for high speed, the mixture is too lean for low speed. A simple carburetor that will produce a well-balanced mixture for all speeds has not yet been devised. Properly proportioned mixtures for the different speeds can be obtained approximately with complicated carburetors containing properly designed and adjusted auxiliary air valves. These carburetors are accordingly more expensive.

**B. Reference Work.** Use *Motor Vehicles* or other text.

1. What is meant by carburetion?
2. What determines the efficiency of combustion?
3. Are surface or spray carburetors more commonly used to-day?
4. Name four valves common to carburetors.
5. Diagram a carburetor containing an auxiliary air port. Name the parts.

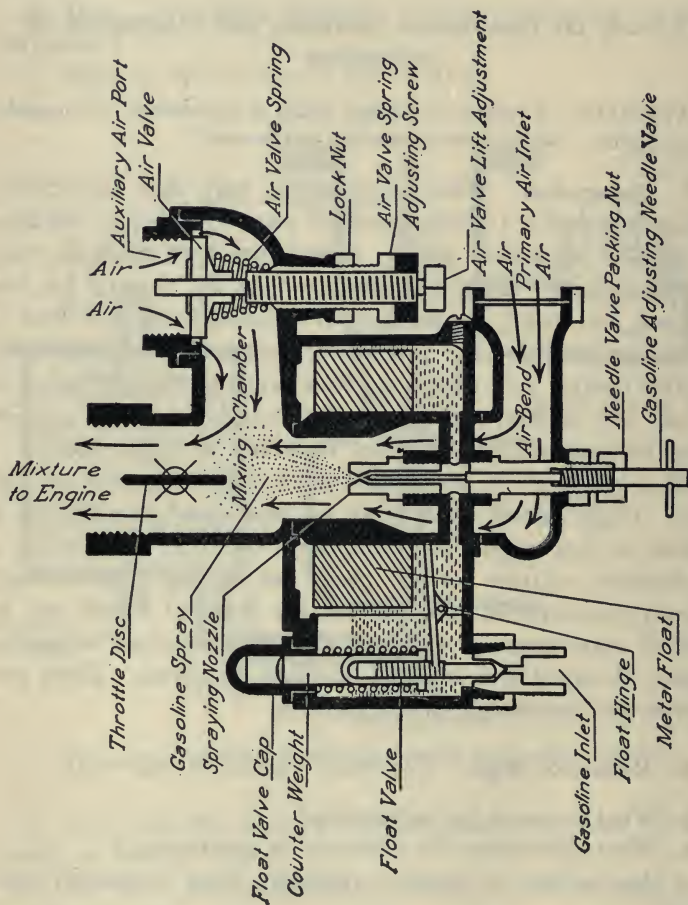

FIG. 92.— A carburetor with concentric float chamber.

### C. Troubles and Adjustment.

6. What is the purpose of a secondary or auxiliary air inlet on a carburetor?

7. What is meant by "adjusting a carburetor"?

8. If the float should leak, what effect might be produced upon the carburetor?

9. A very lean mixture burns slowly. Explain how this may result in an explosion in the carburetor (popping back) when the engine runs slowly.

10. If the ignition current is shut off in going down a hill and the engine is allowed to run, a loud explosion sometimes occurs in the muffler at the bottom of the hill when the current is again turned on. Explain.

11. How can a "rich mixture" be detected?

12. What are some causes of a "lean mixture"?

13. If a piece of dirt should become clogged in the float needle socket, what might be the result?

14. By what change of adjustment could you make the mixture richer in case the engine missed fire, or developed insufficient power on account of the mixture being too lean?

15. State some important steps in the adjustment of a carburetor. See Frazer and Jones.

## 89. FORD ENGINE — A

To study the construction and operation of the Ford engine.

NOTE. This experiment should be preceded by experiments, — Gasoline Engine — A and Gasoline Engine — B.

MATERIALS. Ford chassis, second-hand (radiator, cylinder head, and one piston removed); reference books, *The Model T Ford Car*, Page, and *The Ford Manual*.

The most expensive and the largest single unit of the automobile mechanism is the engine. Upon its design, material, and workmanship, the efficiency of the operation depends. An engine that is defective in design or adjustment may be very wasteful of gasoline. If the parts of the engine include cheap material and cheap workmanship, its life may be only half as long as it should be. The modern gasoline engine has required years of experimentation and the combined labors of many expert engineers. To appreciate it properly, as a contribution to human comfort and to modern commercial life, it is necessary to know its principal parts and to learn how each part is related to the general operation. The Ford engine has become famous because it is powerful for its size, it is efficient in the use of gasoline, and it stands up well under hard service.

**A. General Characteristics and Operation.** This is an L-type motor. (Intake and exhaust valves are on the same side. The T-type engine has intake on one side and exhaust on the opposite side.) Remove the cylinder head. Take out bolts with a wrench. In answering questions refer to *Ford Manual* and to *The Model T Ford Car* — Page.

1. Are these cylinders cast as a single unit (en bloc), or in parts?

2. What important part of the ignition system is attached to the cylinder head?



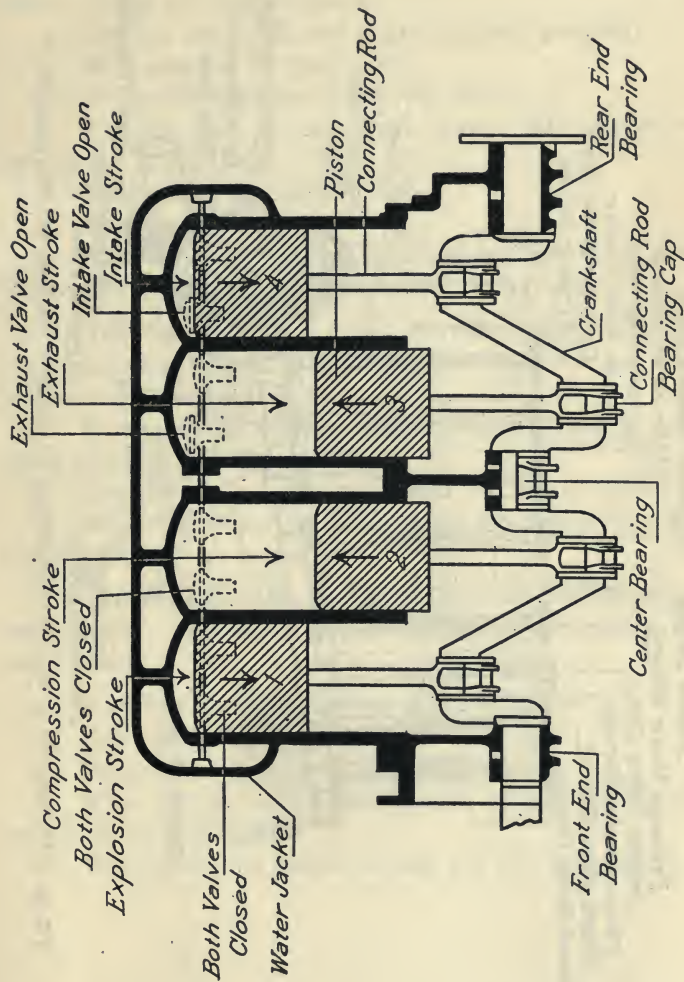

FIG. 93. — Sectional view of a four cylinder automobile engine.

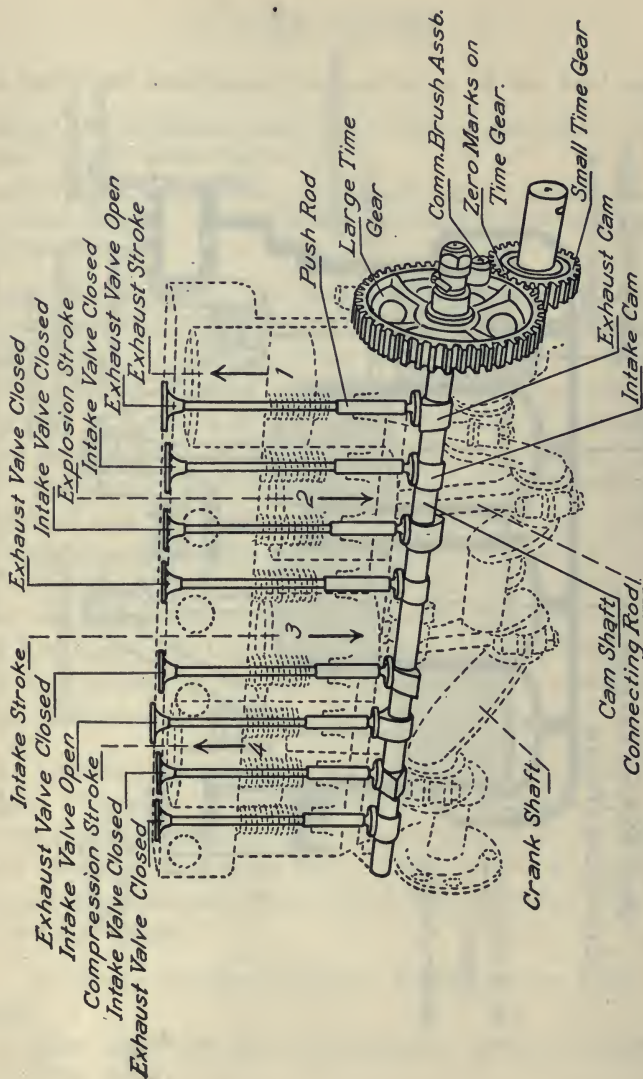

FIG. 94. — Phantom view of the Ford engine showing the time gears, cam shaft, and valve mechanism.

3. How many shafts are inclosed in the crank case? Name them. What are their purposes?
4. How are the intake and exhaust valves operated?
5. What operates the cam shaft?
6. How many cams are on the cam shaft?
7. How fast does the cam shaft revolve with respect to the rate of the crank shaft?
8. What pushes the valves open?
9. What closes the valves?
10. What is the direction of motion of any piston, (a) when its intake valve opens, (b) when its exhaust valve opens?

**B. The Crank Shaft.** Look into the open cylinder and observe the crank shaft. Have some one crank the car and you will note that the crank shaft revolves.

11. At what angle do the cranks stand with respect to each other in a four cylinder engine?
12. How are the crank bearings and the pistons oiled?
13. Name four important parts of the mechanism between the crank shaft and the rear wheels.

**C. The Pistons.** One of the pistons has been removed for examination. The connecting rod attaches the piston to the crank shaft.

14. How does a well-oiled piston aid compression?
15. How many rings has the Ford piston?
16. What is the purpose of piston rings?
17. What kind of combustible mixture tends to deposit carbon on the piston and valves?
18. What causes old pistons to leak and lose compression?

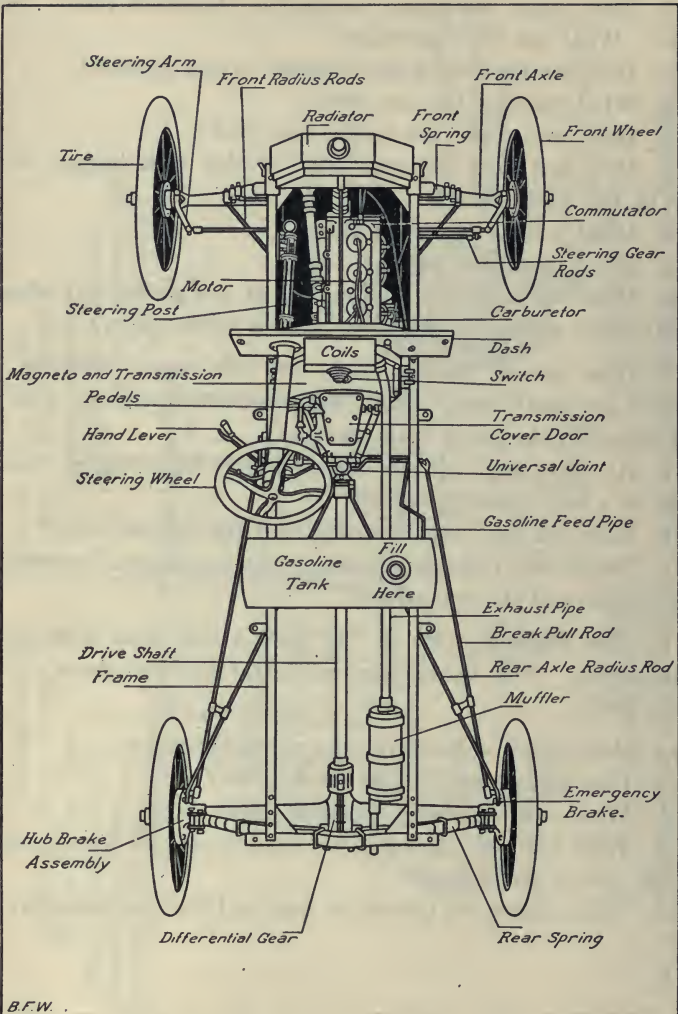

FIG. 95. — The Ford chassis, showing location of important parts of the mechanism.

90. FORD ENGINE — B

MATERIALS. Same as in Ford Engine — A. Reference Book, *The Model T Ford Car*, Page.

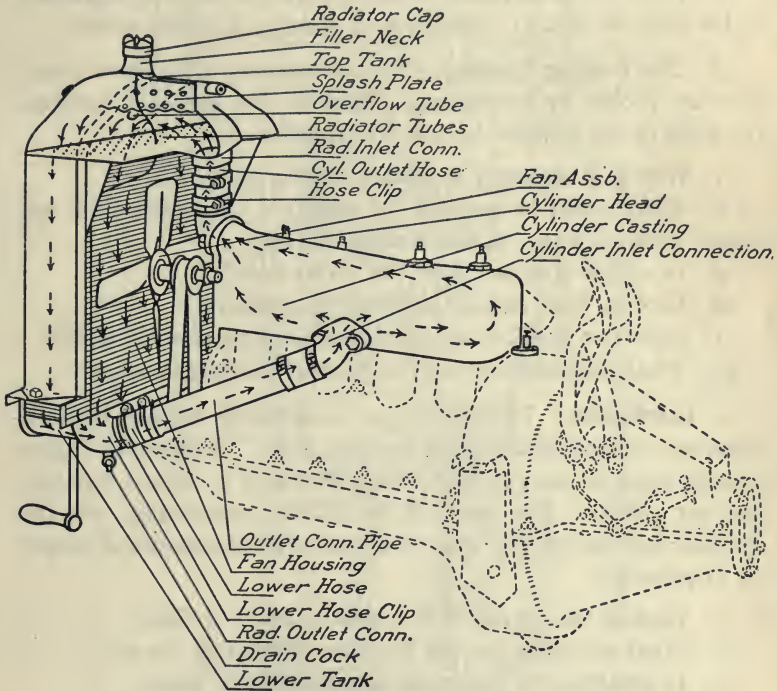

FIG. 96. — The Ford cooling system — a convection circuit.

A. **The Ford Timer.** Remove the timer cap. The purpose of the timer is to determine the time at which current is sent to each induction coil and consequently to each spark-plug.

1. To which shaft is the timer attached?
2. How many contact points does the timer have?
3. What touches these points, sending currents to the induction coils and spark plugs?

4. How many sparks are produced in this four cylinder engine for each turn of the crank-shaft?

5. Where is the electric generator located in the Ford?

6. What is the sequence of firing in the cylinders, beginning at the front as No. 1? Sequence of opening of intake valves.

**B. The Cooling System.** (Thermo-Siphon.) The Ford cylinders are cooled by convection. Examine the openings between the walls of the cylinder for water circulation.

7. Why is it necessary to have a cooling system?

8. What would be some of the results if the engine were operated without water in the cooling system?

9. In which direction does the water flow?

10. Explain what causes the water to circulate.

11. State two possible causes of trouble in the cooling circuit.

12. What chemicals are used to prevent freezing in winter?

**C. Lubrication.** The life of an automobile engine depends upon proper lubrication of the working parts. Automobile engine pistons move at rates as high as one thousand to fifteen hundred feet per minute. The metal of the pistons, piston rings, and the cylinder wall will rapidly wear away unless an abundance of proper oil is provided.

13. Explain the operation of a splash system of oiling.

14. What provision has the Ford for circulating the oil?

15. In what part of the crank case does the oil stand?

16. If the engine should become overheated, how would this affect the engine oil?

17. What parts of a crank shaft need oil?

18. What parts of a piston connecting rod need oil?

**D. The Manifolds.** Note the position of the intake manifold which leads the combustible mixture from the carburetor to the intake valves. The exhaust manifold leads the burnt gases from the exhaust valves to the muffler.

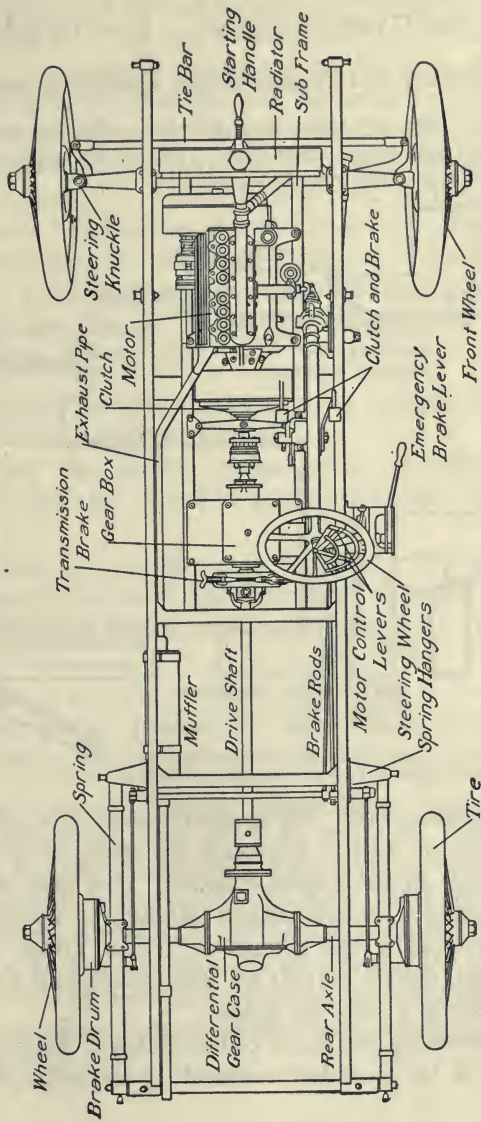

FIG. 97. — Chassis of an automobile, showing the location of parts.

## 91. IGNITION SYSTEMS — A — SIMPLE

To construct and operate simple ignition systems.

**MATERIALS.** Four dry cells; insulated wires; vibrating induction coil; metal ring stand; automobile spark plug. (Part of the apparatus for this experiment must be obtained from the instructor.)

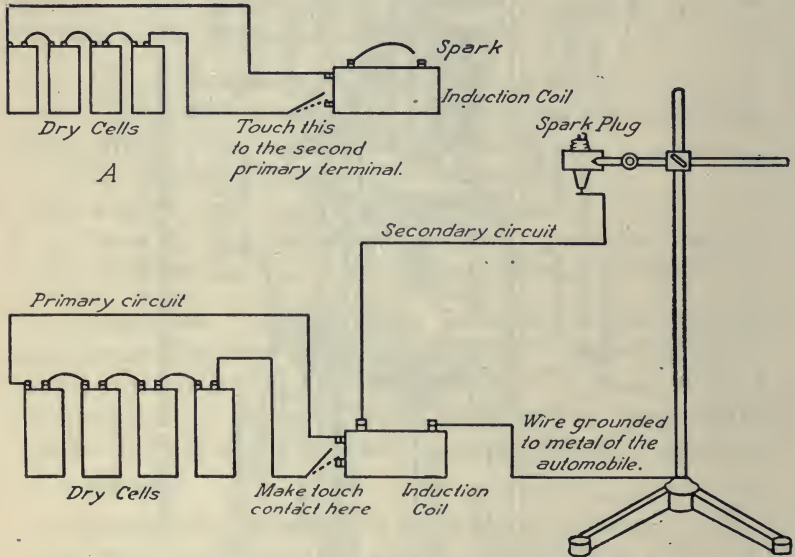

FIG. 98. — Simple ignition system containing primary and secondary circuits.

**A. The Induction Coil.** An ignition system in a gas engine, or an automobile, is used to produce a hot spark for igniting the explosive mixture in the engine cylinder. This may be accomplished by sending a six-volt current through an induction coil, and thereby increasing the voltage to ten or fifteen thousand volts. This high voltage current will pass through air for a short distance, producing a very hot spark.

Operate a vibrating induction coil as follows: Attach a short wire from one of the secondary terminals of the induction coil to



within a quarter of an inch of the other secondary terminal, but not touching it. This quarter-inch opening will form the spark gap. An induction coil should not be operated with the spark gap too wide, as this may puncture the insulation of the secondary coil and ruin it. Connect four dry cells in series. (*Caution. The current from the secondary terminals of an induction-coil is dangerous. Keep away from it.*) Attach one wire from the dry cells to one of the primary terminals of the induction-coil. Touch the other wire from the dry cells to the other primary terminal of the induction coil. A spark should jump across the spark gap of the secondary terminals. Do not handle the induction coil without first disconnecting the dry cells.

1. Diagram an induction coil. See Carhart and Chute or Millikan, Gale and Pyle.

2. Should the current which passes through the primary winding of this type of coil be a continuous flow, or an intermittent flow?

3. Explain the purpose of the vibrator. If the vibrator does not operate, it may need some adjustment. Consult the instructor.

4. What pulls the vibrator toward the coil? What draws it back?

5. What is a condenser made of? What is its function? In automobile ignition systems, the timer usually serves the purpose of the vibrator and the induction coil does not contain a vibrator.

**B. The Secondary Circuit — Spark Plug.** Disconnect the batteries, temporarily, from the induction coil. Remove the wire from the secondary terminals. Fasten an automobile spark plug to the clamp of the ring stand. Connect a well-insulated wire from one secondary terminal of the induction coil to the spark plug. Connect a second wire from the other secondary terminal to any metal part of the ring stand. Operate the induction coil as before and the secondary current should jump across the spark gap of the spark plug.

6. Diagram a sectional view of a spark plug and tell of what materials it is made. See *Motor Vehicles* — Frazer and Jones.

7. The secondary circuit is grounded through the ring stand. What is meant by the term "grounded circuit"?

C. Reference Work. *Automobiles* — Zerbe.

8. What is meant by the expressions "high-tension current," and "low-tension current"?

9. What should be the width of the spark gap on a spark-plug?

10. What three common methods are employed for producing current for ignition purposes?

11. What are the two common types of magnetos?

12. How can the spark plug of an automobile be tested to insure that it sparks?

13. State three possible causes of trouble in the electric circuits.

## 92. IGNITION SYSTEMS — B

To study the operation of automobile and gas engine ignition systems.

**MATERIALS.** Four dry cells; vibrating induction coil; four metal ring stands; four spark plugs; wooden block with four binding posts; non-vibrating induction coil (make and break coil). (Part of the apparatus for this experiment must be obtained from the instructor.)

**A. Automobile Ignition System.** Attach four spark plugs to four ring stands. Connect the four stands by means of a wire, and extend this wire to one terminal of the induction coil. From the four spark plugs lead four well-insulated wires to four binding-posts placed near the corners of a square, wooden block. Attach a well-insulated wire to the second terminal of the vibrating induction coil. Insulate this wire by pulling a piece of rubber tubing over it. (*Caution. The secondary current is dangerous.*)

*Keep away from the secondary wires when the batteries are attached.)* When this wire is placed in contact with any one of the posts on the wooden block, you should get a spark at the spark plug which that post controls. This block with the four posts represents the “distributor” of a four-cylinder automobile ignition system.

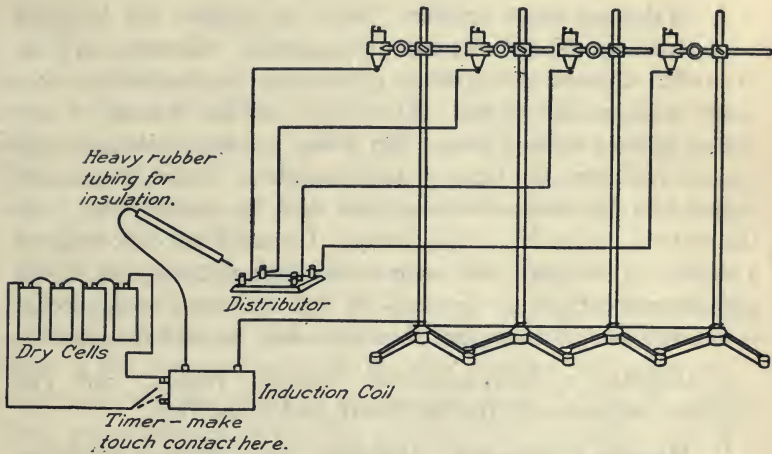

FIG. 99. — Ignition system, illustrating the operation of the timer and the distributor on an automobile.

The closing of the battery circuit (primary circuit) by touching one wire to one of the primary terminals of the induction coil, represents the “timer” of an automobile ignition system.

Automobiles as a rule do not have vibrating coils. The timer makes and breaks the primary current, serving the purposes of the vibrator. The Ford ignition system is an exception. The Ford car is provided with four vibrating coils, — one for each cylinder.

In many of the common types of cars, the low voltage current supply for operating the induction coil is taken from the storage battery.

1. Diagram the apparatus used above, showing dry cells, induction coil, spark plugs, and distributor,

2. State one sequence of firing for a four-cylinder engine. See Page.

3. What is the purpose of the ignition switch on the instrument board of an automobile?

4. What is the purpose of the distributor?

**B. Make-and-break Ignition.** Some gas engines are operated by a "make-and-break" spark (wipe spark). Connect up four dry cells. Connect a wire from one terminal of the battery to a simple make-and-break coil. This device consists of a coil of wire wound around an iron core. Slip a heavy rubber tube over the second wire from the battery, for insulation. Touch the second terminal of the make-and-break coil with the second wire from the battery, and pull it quickly away. Use one hand only to avoid a shock. A hot spark will occur at the time of break, due to the self-induced current in the coil. If this make-and-break occurs in the cylinder of an engine, the spark may be used for ignition.

5. Diagram a make-and-break ignition system. See *The Gasoline Automobile* — Hobbs, Elliott, and Consoliver.

**C. Magneto Generators.** Magnetos are sometimes employed as sources of current for ignition. These generators take the place of the battery. They are either of the high-tension or the low-tension types. The low-tension magneto requires a separate induction-coil. The high-tension magneto contains the induction coil in the magneto.

**D. Reference Work.** *The Gasoline Automobile* — Hobbs, Elliott, and Consoliver.

6. Make a diagram showing the main parts of a typical ignition-system, including induction coil and distributor.

7. State at least five possible causes of failure of an ignition system to produce a spark.

## 93. IGNITION SYSTEMS -- C, FORD IGNITION

To study and operate the Ford ignition system.

Reference. *The Model T Ford Car* — Page.

MATERIALS. Ford engine. Five dry cells.

**A. The Sequence of Firing.** If you examine the positions of the pistons of the engine, you will note that when No. 1 and No. 4 are on top center (all the way up), No. 2 and No. 3 are on the bottom center (the lowest point they reach in the cylinder), and vice versa. This is the case with all typical four-cylinder, four-cycle, gasoline engines. The cranks, therefore, are set one-half a revolution or  $180^\circ$  apart.

In a four-cycle, four-cylinder engine, the complete operation consists of four strokes, or half revolutions — intake, compression, explosion, and exhaust. The explosion occurs on or near the top center of the compression stroke in each cylinder, the other top center being the top center of the exhaust stroke. However, the valves and cranks are so set that at every half revolution one of the cylinders is ready to fire. Suppose that No. 1 and No. 4 are on top dead center. One is on top center of the compression stroke, and the other is on top center of the exhaust stroke.

A four-cylinder engine may fire in the sequence one, three, four, two, or one, two, four, three.

1. Locate the four intake valves by their connection with the intake manifold. Number them in the series of eight valves, beginning at the front.

2. Determine the firing sequence of the cylinders by noting the sequence of the opening of the intake valves. The firing sequence is the same as the valves sequence.

**B. The Induction Coil.** An induction coil is a device for increasing the voltage of a few dry cells in order to obtain a hot spark. Four dry cells deliver about six volts. At this pressure

(voltage) the spark is insignificant and could not be used for ignition. However, if this current is sent through an induction-coil, the pressure from the secondary terminals of the coil is changed to ten or fifteen thousand volts. This high-voltage current will easily jump across the terminals of a spark plug and make a hot spark. (*Caution. The high-voltage current from the secondary of an induction-coil is very disagreeable and sometimes dangerous. Be careful. Do not attach the batteries to the primary terminals until all other connections are made. Keep hands away from the secondary circuit when the primary is operating.*) Connect one of the secondary terminals of a separate induction coil (use one of the laboratory coils) to one of the spark plugs in the cylinder head by means of an insulated wire. Connect the other terminal to the frame of the car. Attach four dry cells to the primary terminals of the coil in series with a telegraph key as a make-and-break. Operate the spark across the spark plug by pushing the key.

3. How does the secondary current flow from the one terminal attached to the spark plug back to the other terminal of the coil?

**C. The Wiring, Timer, Coils, Spark Plugs.** The charge is exploded in each cylinder by an electric spark which jumps across the points of the spark plug. Each spark plug receives its current from the induction coil to which it is attached. The Ford has a separate vibrating coil for each spark-plug. The time at which the spark occurs is regulated by the timer which is inclosed in the round, aluminum casting with four terminals situated to the left of the crank-handle of the engine. It is held in place by a steel clamp. Push the clamp aside, take off the timer cap and examine it. Now crank the engine over and see what happens to the little roller which the cap covers. Refer to *The Model T Ford Car* or *The Ford Manual*.

4. What is the function of this roller?

5. At what rate does the timer revolve with respect to the speed of the engine?

6. To the end of what shaft is the timer attached?
7. What causes this shaft to revolve?
8. What other office does this shaft perform?
9. The timer cap is attached to the spark lever on the steering wheel by means of a rod. How does moving the spark lever advance or retard the time of the spark in the cylinders?

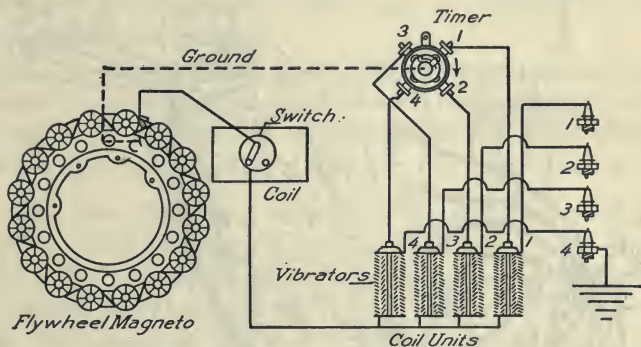

FIG. 100. — The Ford ignition system.

10. When the engine is running fast, should the spark be advanced or retarded to get best power?

11. With respect to the explosion in the cylinder, what is meant by advancing or retarding the spark? See Zerbe, Page, or Hobbs, Elliott, and Consoliver.

Replace the timer cap, reset the clamp and connect four well-insulated wires from the four terminals of the timer cap, to the four upper terminals of the coil box. At the timer cap these wires should touch only the binding posts, not the cap or engine metal. Connect the four lower terminals on the coil box with the spark plugs by means of well-insulated wires. Make a dry cell battery by connecting five or six cells in series, and connect one terminal of the battery to the lower left-hand terminal on the coil box. Ground the other terminal of the battery by connecting a wire from it to some metal part of the engine. Now

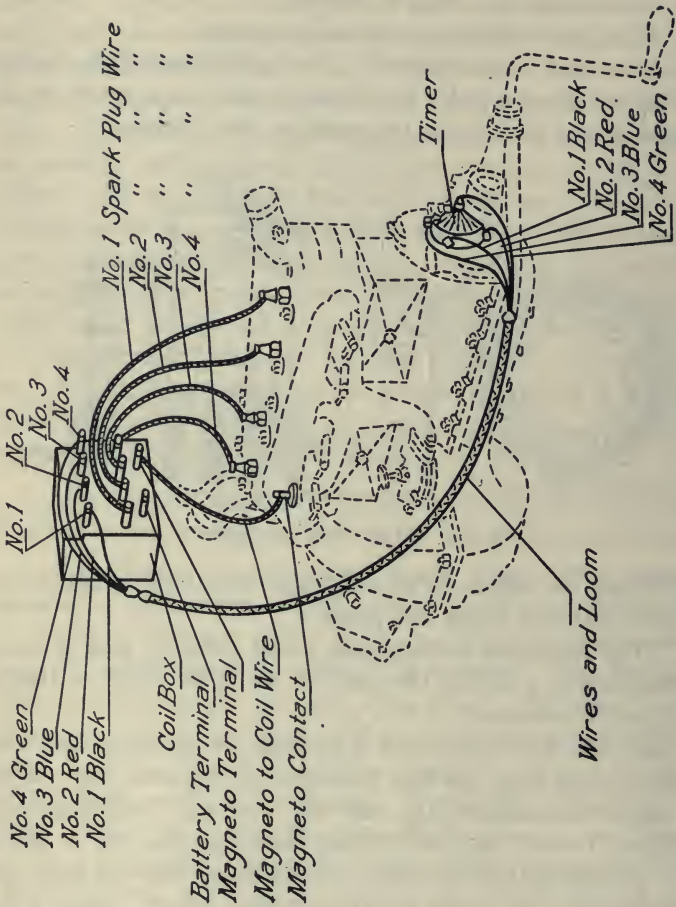

FIG. 101. — Ford ignition system.



push the switch on the front of the coil box over to the left, and crank over the engine. Notice the sequence of firing and if it is not the proper sequence as determined in *A*, change the wires leading from the timer to the coil, or from the coil to the spark plugs, until the sequence is correct.

12. Remove one of the wires leading to the terminals of the timer cap. Touch the engine metal with it. Explain the result. What is a grounded circuit?

13. If the ignition switch on the coil box is set to take current from the dry cells, and the car stops with timer roller in contact with one of the wires leading to an induction coil, what would be the effect upon the dry cells? How can the driver prevent this?

**D. The Ford Generator.** The Ford should be started on the dry cells. When the engine is running, the switch on the coil box can be turned, connecting the coils with the generator in place of the dry cells and thus save the dry cell current.

The Ford generator is a special type of low tension, magneto generator attached to the flywheel. A number of large bar magnets are attached to the flywheel. These magnets move in the presence of a series of coils of wire attached to a stationary frame. These magnets induce an alternating current in the coils. This current is used for operating the induction coils.

14. Attach a wire from the top of the coil frame on the generator to the lower right-hand post on the coil box. Turn the coil switch, connecting up the magneto. If the engine is now cranked rapidly, the magneto will operate the induction coils and spark plugs.

## 94. STORAGE BATTERY — A

To study the construction and operation of a lead storage cell.

**MATERIALS.** Simple storage cell; dilute solution of common salt; battery voltmeter; ammeter; electric bell; 2-volt lamp; small 2-volt motor; lamp board and one-ampere lamp; 110-volt or lower voltage direct current.

*Caution.* Sulfuric acid will destroy clothing and cause burns. Handle with extreme care.

Outlet for 110 volt direct current

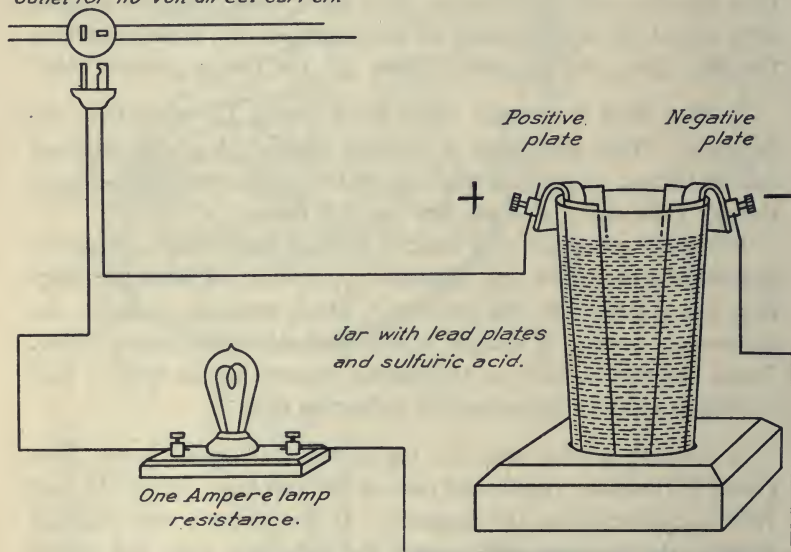

FIG. 102. — Wiring scheme for charging a simple storage battery.

A. Make a simple storage cell by filling a battery jar three-fourths full of a twenty per cent solution of sulfuric acid. Suspend in it two plates of ordinary sheet lead, by folding the lead plates over the edges of the jar. With a one-ampere lamp as rheostat, prepare to send a 110-volt direct current through the cell, or to send a direct current from a small generator. (*Caution.*

*Do not connect the cell directly to the line-wires without resistance, as this would blow out the fuse.)* Test the charging current with a salt solution (a quarter teaspoonful in a tumblerful of water) to

*Outlet for 110 volt direct current*

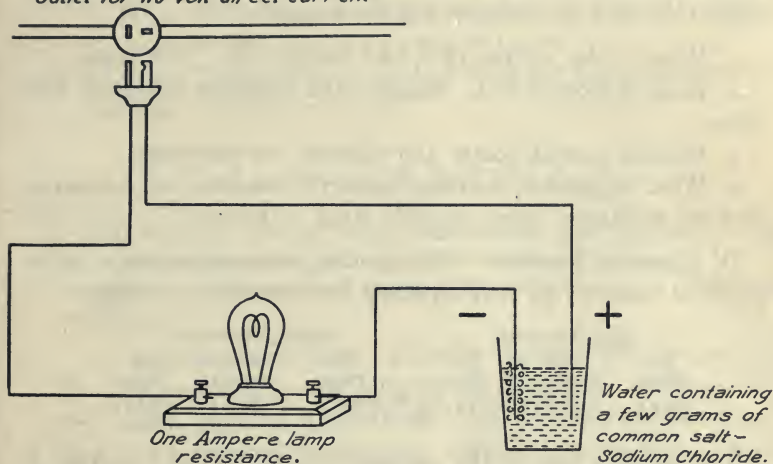

FIG. 103. — Wiring for testing a direct current for positive and negative terminals.

find which terminal is negative. In making this test attach the lamp in series with one wire to insure against a short circuit if the wires should accidentally touch in the salt solution. The negative terminal gives off more bubbles. Connect the brown-coated plate (positive) to the positive terminal of the line current. In charging, connect positive to positive and negative to negative.

The charging current should pass through the cell from positive to negative. Hydrogen is set free at the negative plate and oxygen at the positive (electrolysis). The oxygen, instead of escaping into the air, attacks the lead, forming a brown coat of  $\text{PbO}_2$ , lead peroxide. When the cell is charged, the positive plate coated with lead peroxide and the negative plate of pure lead act similar to the positive and negative plates of any simple liquid cell.

Allow the current to pass through this cell for fifteen minutes.

(Read Black and Davis on the storage battery.) Disconnect from the charging lines and test the pressure with a voltmeter. (*Caution. Do not connect an ammeter to a storage battery without some resistance as a motor or a lamp in series with the meter, as this might ruin both the ammeter and the battery.*)

1. What is the voltage of a lead storage cell? See texts.
2. Ring an electric bell. Measure the amperage which the bell takes.
3. Operate a small motor and measure the amperage.
4. What happens to a storage battery if the wires are connected without resistance (some suitable lamp or motor)?

**B. Chemical Reaction.** Disregarding intermediate steps in the chemical reaction, we may represent the operation as follows:

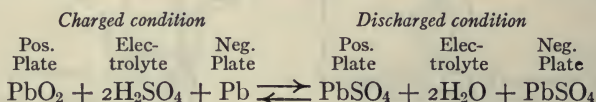

The reaction goes in the opposite direction when a current is reversed through the cell in the operation of charging it. The cell does not store up electricity. The energy of the charging current is used in the formation of lead peroxide on the positive plate. When the charging current stops, the two plates, on account of their different chemical nature, act like a simple liquid cell, which, on account of the chemical difference between the two plates, is capable of producing a reaction with the electrolyte and generating a current. The hydrogen ions of the sulfuric acid unite with the oxygen of the lead peroxide, forming water, and  $\text{SO}_4$  ions go to produce lead sulfate on both plates. Thus on full charge the sulfuric acid is concentrated and on discharge it is dilute. The specific gravity is, therefore, a fairly good test of the charged or discharged condition of the cell. The electrolyte, however, must be kept full by the addition of distilled water, since evaporation reduces it.

**Reference Work.** Black and Davis, *Practical Physics*.

5. When a storage battery is discharged what chemical compound covers the plates?
6. What are some disadvantages of a lead storage battery?
7. What efficiency is obtained from a battery in good condition?
8. Mention three uses for storage batteries.
9. In the Edison storage battery what are the plates composed of and what electrolyte is used?

## 95. STORAGE BATTERY — B

**MATERIALS.** Storage Battery (commercial type preferably in glass jar); battery hydrometer; battery ammeter, rheostat.

*Caution.* Sulfuric acid will destroy clothing and cause burns. Handle with extreme care.

**A. Operation and Care.** Examine the large storage batteries. Test by means of a salt solution as in Storage Battery—A to find which terminal is negative. Test the line current also to find which terminal is negative. With a three-ampere rheostat in series, prepare to force a current through the battery in reverse direction (positive connected to positive, and negative to negative). (*Caution.* Have your scheme of wiring inspected by an instructor before turning on the current, to avoid a possibility of ruining the batteries.) If necessary, distilled water should be added so that the electrolyte stands one quarter inch above the plates. The time required for complete charge from condition of discharge is usually fifteen to twenty hours.

1. Do not attach an ammeter without resistance. Why?
2. Note the specific gravity at the beginning of charge.
3. Charge for fifteen minutes. This brief time will not make a noticeable change on the specific gravity. Does the acid become more or less concentrated on charging? Refer to texts. See Black and Davis.
4. What is the combined voltage of two cells in series?

5. Attach a suitable motor in series with a battery ammeter and operate it. How much current does the motor take?

Storage batteries are commonly rated as having a certain output in ampere-hours. An ampere-hour means a flow of one ampere for one hour. A twenty-ampere-hour battery means that the

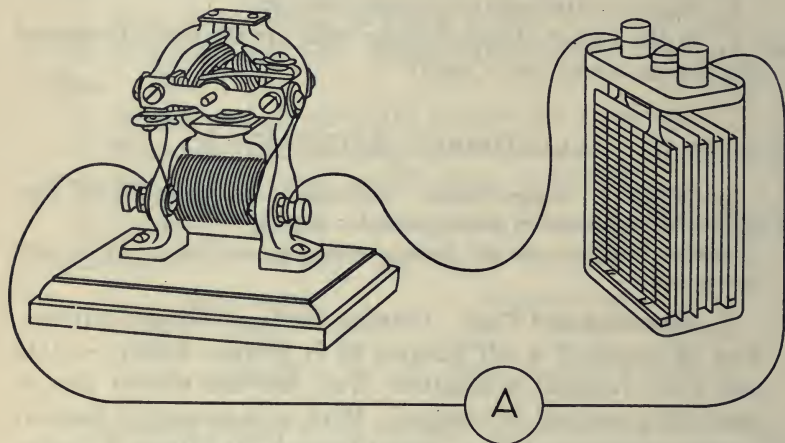

FIG. 104. — A storage battery operating a motor with an ammeter in the circuit.

battery can supply a current of one ampere for twenty hours, after which it should be recharged. If larger amperages are taken, the time will be reduced.

**B. Care of Lead Battery.** (a) Use only pure water and pure acid for electrolyte. (b) Avoid overcharging and overdischarging. (c) Do not allow the battery to stand discharged, as it will become sulfated and sometimes permanently injured.

In the self-starting systems of automobiles, storage batteries are required to deliver fifty to two hundred amperes at about six volts for a few moments in starting the engine. This large amperage would soon exhaust a storage battery. The starting motor should be operated for very short periods only. Lead storage batteries are well suited for this work, because they can deliver

an enormous current for a short time, due to their very low internal resistance. Automobile storage batteries have a specific gravity at complete charge 1.3, and at complete discharge 1.15.

*C. Reference Work. Electricity Experimentally and Practically Applied* — Ashe.

6. When was the storage battery invented and by whom?
7. What two forms of lead are used in the making of plates?
8. How does the formation of lead sulfate reduce the efficiency of the cell?
9. What is meant by the expression, — 10-ampere, eight-hour cell?
10. If cells are discharged too rapidly, what tends to reduce their efficiency?





## APPENDIX

### LABORATORY REFERENCE SHELF

#### A. PHYSICS TEXTS.

- Practical Physics* — Black and Davis . . . . . 3 copies  
The Macmillan Co., N. Y.
- Practical Physics* — Millikan, Gale and Pyle . . . . . 3 copies  
Ginn & Co., N. Y.
- Physics With Applications* — Carhart and Chute . . . . . 3 copies  
Allyn & Bacon, Boston.
- Physics* — Mann and Twiss . . . . . 3 copies  
Scott Forsman & Co., Chicago.
- Essentials of Physics* — Hoadley . . . . . 3 copies  
American Book Co., N. Y.
- The Ontario Physics* — Merchant and Chant . . . . . 3 copies  
The Copp, Clark Co., Ltd., Toronto, Canada.
- Household Physics* — Butler . . . . . 2 copies  
Whitcomb & Barrows, Boston.
- Household Physics* — Lynde . . . . . 2 copies  
The Macmillan Co., N. Y.
- College Physics* — Kimball . . . . . 1 copy  
Henry Holt & Co., N. Y.

#### B. GENERAL SCIENCE TEXTS.

- General Science* — Barber . . . . . 2 copies  
Henry Holt & Co., N. Y.
- General Science* — Hodgdon . . . . . 2 copies  
Hyndes, Hayden & Eldredge, N. Y.

#### C. BOOKS ON SPECIAL SUBJECTS.

- Mechanics of the Household* — Keene . . . . . 2 copies  
McGraw-Hill Book Co., N. Y.
- The Wonder-book of Light* — Houston . . . . . 1 copy  
Frederick A. Stokes & Co., N. Y.
- How to Make Good Pictures* . . . . . 1 copy  
Eastman Kodak Co., Rochester.
- Electricity Experimentally and Practically Applied* — Ashe . . . 1 copy  
D. Van Nostrand Co., N. Y.

<i>Elements of Electricity</i> — Timbie . . . . .	1 copy
John Wiley & Sons, N. Y.	
<i>Weather</i> — Jameson . . . . .	1 copy
Taylor Instrument Companies, Rochester.	
<i>Mechanics of the Sewing Machine</i> — N. E. A. Bulletin . . . . .	5 copies
Singer Sewing Machine Co., N. Y.	
<i>Smithsonian Physical Tables</i> . . . . .	1 copy
Smithsonian Institution, Washington, D. C.	
<i>Motor Vehicles</i> — Frazer and Jones . . . . .	1 copy
D. Van Nostrand Co., N. Y.	
<i>The Gasoline Automobile</i> — Hobbs, Elliott and Consoliver . . . . .	1 copy
McGraw-Hill Book Company, N. Y.	
<i>The Model T Ford Car</i> — Page . . . . .	1 copy
Norman W. Henley Pub. Co., N. Y.	
<i>Wireless Telegraphy and Telephony</i> — Morgan . . . . .	1 copy
Norman W. Henley Pub. Co., N. Y.	

## BOOKS FOR REFERENCE AND READING

NOTE. A briefer list includes those marked with a star.

### GENERAL READING

- \* *The Wonders of Science in Modern Life* (10 small volumes) — Williams  
Funk & Wagnalls Co., N. Y.
- Romance Series — Historical, Informational, Interesting. Volumes on :
 

* <i>Aeronautics.</i>	<i>Engineering.</i>
* <i>Submarine Engineering.</i>	<i>Locomotion.</i>
<i>Modern Electricity.</i>	<i>Mining.</i>
<i>Astronomy.</i>	* <i>Photography.</i>
- Seeley Service & Co., London, also  
J. B. Lippincott & Co., Philadelphia.
- \* *Inventors at Work* — Iles.  
Doubleday, Page & Co., N. Y.
- \* *Leading American Inventors* — Iles.  
Doubleday, Page & Co., N. Y.
- Stories of Useful Inventions* — Forman.  
Century Co., N. Y.
- \* *A Century of Electricity* — Mendenhall.  
Houghton, Mifflin & Co., Boston.
- All About Inventions and Discoveries* — Talbot.  
Funk and Wagnalls Co., N. Y.

- Boys' Book of Inventions* — Baker.  
Doubleday, Page & Co., N. Y.
- \* *The Boys' Life of Edison* — Meadowcroft.  
Harper & Bros., N. Y.
- Galileo — His Life and Work* — Fahie.  
James Pott & Co., N. Y.
- Heroes of Science* — Physicists (out of print).  
E. and J. B. Young & Co., N. Y.
- Famous Men of Science* — Boulton.  
Thomas Y. Crowell & Co., N. Y.
- Children's Stories of the Great Scientists* — Wright.  
Chas. Scribner's, N. Y.

## GENERAL BOOKS OF REFERENCE

- \* *Ganot's Physics* — Atkinson.  
Wm. Wood & Co., N. Y.
- A Text Book of Physics* — Watson.  
Longmans, Green & Co., N. Y.
- General Physics* — Crew.  
The Macmillan Co., N. Y.
- \* *Architects and Builders Pocket Book*.  
John Wiley & Sons, N. Y.
- Bulletins of U. S. Bureau of Standards and Department of Agriculture.  
Washington, D. C.
- \* *Smithsonian Physical Tables*.  
Smithsonian Institution, Washington, D. C.
- Physics of Agriculture* — King.  
Mrs. F. W. King, Madison, Wis.
- \* *Agricultural Engineering* — Davidson.  
Webb Pub. Co., St. Paul, Minn.

## SPECIAL DIVISIONS OF PHYSICS

## A. Mechanics and Heat.

- \* *A New Astronomy* — Todd.  
American Book Co., N. Y.
- Astronomy Series* — Ball.  
J. B. Lippincott & Co., Phila.
- \* *Astronomy for All* — Burgel.  
Cassell & Co., London.

- Mechanical Movements, Powers and Devices* — Hiscox.  
Norman W. Henley Pub. Co., N. Y.
- \* *All About Engineering* — Knox.  
Funk & Wagnalls Co., N. Y.
- The Earth's Atmosphere* — Phixson.  
Chas. Griffin & Co., London.
- \* *Sounding the Ocean of Air*.  
E. S. Gorham, N. Y.
- All About Air Craft* — Simmonds.  
Funk & Wagnalls Co., N. Y.
- Kite Craft and Kite Movements*.  
The Manual Arts Press, Peoria, Ill.
- \* *All About Engines* — Cressy.  
Funk & Wagnalls, N. Y.
- Practical Steam and Hot Water Heating and Ventilation* — King.  
Norman W. Henley Pub. Co., N. Y.
- \* *Home Water Works* — Lynde.  
The Macmillan Co., N. Y.
- \* *Heat* — Ogden.  
Popular Mechanics Co., Chicago.
- \* *Liquid Air* — Sloane.  
Norman W. Henley Pub. Co., N. Y.
- Heat a Mode of Motion* (Old Classic) — Tyndall.  
D. Appleton & Co., N. Y.
- Story of a Tinder Box* — Tidy.  
E. S. Gorham, Pub. N. Y.
- Motor Vehicles* — Frazer and Jones.  
D. Van Nostrand Co., N. Y.
- Mechanical Refrigeration, Elevators, and Steam Turbines*.  
Joseph G. Branch Co., Chicago.

## B. Light and Sound.

- Waves and Ripples in Water, Air, and Ether* — Fleming.  
Edwin S. Gorham, Pub. N. Y.
- \* *Light Visible and Invisible* — Thompson.  
The Macmillan Co., N. Y.
- \* *Moving Pictures* — Talbot.  
William Heineman, London.
- \* *The Wonder Book of Light* — Houston.  
Frederick A. Stokes Co., N. Y.

- Light-ships and Light-houses* — Talbot.  
William Heineman, London.
- Color and Its Applications* — Luckiesh.  
D. Van Nostrand Co., N. Y.
- \* *Modern Illumination* — Horstmann and Tousley.  
Frederick J. Drake Co., Chicago.
- \* *How to Make Good Pictures.*  
Eastman Kodak Co., Rochester, N. Y.
- \* *Photography of Today* — Jones.  
Seeley Service & Co., London.
- \* *Theory of Sound in Relation to Music* — Blaserna.  
D. Appleton & Co., N. Y.
- Sound and Music.*— Zahm (out of print).  
A. C. McClurg Co., Chicago.
- Sound in its Relation to Music* — Hamilton.  
Chas. H. Ditson & Co., N. Y.
- The Hand Craft Series* — Hasluck.  
Violins.  
Pianos, etc.  
David McKay, Pub., Phila.

### C. Electricity.

- \* *Harper's Electricity Book for Boys* — Adams.  
Harper & Bros., N. Y.
- \* *The Boy Electrician* — Morgan.  
Lothrop, Lee & Shepard, Boston.
- \* *Harper's How to Understand Electrical Work* — Onken.  
Harper & Bros., N. Y.
- \* *All About Electricity* — Knox.  
Funk & Wagnalls Co., N. Y.
- \* *Electricity and its Everyday Uses* — Woodhull.  
Doubleday, Page & Co., N. Y.
- The Elements of Electricity* — Timbie.  
John Wiley & Sons, N. Y.
- \* *Alternating Currents Simplified* — Burns.  
Joseph G. Branch Co., Chicago.
- Electricity Experimentally & Practically Applied* — Ashe.  
D. Van Nostrand Co., N. Y.
- Electricity at High Pressures and Frequencies* — Transtrom,  
Joseph G. Branch Co., Chicago.

*Essentials of Electricity* — Timbie.

John Wiley & Sons, N. Y.

\* *Electricity for the Farm* — Anderson.

The Macmillan Co., N. Y.

*Wireless Telegraphy & Telephony* — Morgan.

Norman W. Henley Pub. Co., N. Y.

*Electric Cooking, Heating and Cleaning* — Lancaster.

D. Van Nostrand Co., N. Y.

*Matter and Electricity* — Comstock & Troland.

(Electron theory in simple language.)

D. Van Nostrand Co., N. Y.

*Electric Wiring* — Branch.

Joseph G. Branch Co., Chicago.

#### D. Books on Special Subjects.

*Hand Craft Series* — Hasluck (50¢ each).

*Electric Bells.*

*Sewing Machines.*

*Photography.*

*Telescope Making.*

*Electroplating.*

*Microscopes.*

*Violins, etc.*

*Dynamos and Motors.*

*Photographic Chemistry.*

*Photographic Cameras, etc.*

*Pianos, etc.*

David McKay, Publisher, Philadelphia.

*Weather and Weather Instruments* — Jameson.

Taylor Instrument Companies, Rochester, N. Y.

\* *Flame, Electricity and the Camera* — Iles.

Doubleday, Page & Co., N. Y.

*Aeroplanes and Dirigibles of War* — Talbot.

J. B. Lippincott Co., Philadelphia.

*All About Railways* — Hartnell.

Funk & Wagnalls, N. Y.

\* *The Modern Clock* — Goodrich.

Hazlitt & Walker, Chicago.

*Time Telling through the Ages* — Brearley.

Doubleday, Page & Co., N. Y.

*All About Ships* — Darling.

Funk & Wagnalls.

\* *Submarines* — Talbot.

William Heineman, London.

*Laboratory Arts* — Wollatt.

Longmans, Green & Co., N. Y.

- The Panama Canal* — Haskins.  
Doubleday, Page & Co.
- The Catskill Water Supply of New York* — White.  
John Wiley & Co., N. Y.
- Physics of Agriculture* — King.  
Mrs. F. W. King, Madison, Wis.
- \* *Agricultural Engineering* — Davidson.  
Webb Pub. Co., St. Paul, Minn.
- \* *Practical Talks on Farm Engineering* — Clarkson.  
Doubleday, Page & Co., N. Y.
- The Autobiography of an Electron* — Gibson.  
J. B. Lippincott & Co., Philadelphia.

## APPARATUS LIST

NOTE. The prices assigned to the items in this list cannot be relied upon in ordering material. Current prices for material should be obtained from dealers before orders are sent. Dealers other than those listed below should guarantee to the customer that the material which they supply is strictly in accordance with the specifications and quality of material referred to in the list. Success in the use of these experiments will depend upon strict adherence to this rule. One complete set of apparatus for all experiments in Group I should cost between fifty and seventy-five dollars. Abbreviations used below are:

- EA = Eimer & Amend, 205 Third Ave., N. Y.  
 SS = Standard Scientific Co., 147 Waverly Place, N. Y.  
 WT = Whitall Tatum Co., 46 Barclay St., N. Y.  
 LK = L. E. Knott Apparatus Co., Boston, Mass.  
 CS = Central Scientific Co., Chicago, Ill.  
 SR = Sears, Roebuck & Co., Chicago, Ill.  
 CW = Charles Williams Stores, New York City.  
 SP = Stanley & Patterson, 23 Murray St., N. Y.

## GROUP I EXPERIMENTS

## A. Material Used in More Than One Experiment.

A1	Bells, electric; SS or CW or SP. 631 Acme, size of gong $2\frac{1}{2}$ in. . . . .	.60
A2	Bottles 12 oz. heavy glass $1\frac{1}{4}$ in. mouth; EA 910-12 oz. . . . .	.10
A3	Bunsen burner, Terrill's; EA 1462 . . . . .	1.00
A4	Candles; SS or SR, per doz. 20¢, Christmas . . . . .	.10
A5	Carbon rods, obtained from worn out dry cells . . . . .	
A6	Carpet tacks, per box . . . . .	.10

A7	Cotter-pins, brass, for holding stopper in place on brass piston rod, size $\frac{3}{8}$ in. diameter $\times$ $\frac{1}{2}$ in. long; W. & J. Tiebout, 118 Chambers St., N. Y., 56¢ per 100 . . . . .	.02
A8	Dry cells, purchase from any electrical store. Red Seal or Columbia are reliable . . . . .	.35
A9	Electric Lamp Pendant Sockets, Miniature (2); SS or SR or SP, Bryant Socket 322 . . . . .	.36
A10	Electric Lamps, Mazda Miniature base, 3 volts (2) at 20¢; SS or SR or SP . . . . .	.40
A11	Funnels; EA 3214, diam. $2\frac{1}{2}$ in., short stem . . . . .	.10
A12	Glass beakers with lip, size 8 oz.; SS 721, at 20¢ . . . . .	.40
A13	Glass flasks (2) flat bottom, capacity 500 c.c., heavy glass, width of mouth 1 in.; in doz. lots, Macbeth Evans Glass Co., Pittsburgh, Pa., 1872, or WT, 2016 at 20¢ . . . . .	.40
A14	Glass L-tubes, 3-in. arms. These tubes can be made by bending 6-in. tubes in a fish-tail Bunsen flame. 4 L-tubes at 8¢; SS . . . . .	.32
A15	Glass L-tube, one arm 8-in. long, one arm 3-in.; SS . . . . .	.10
A16	Brass T-tubes, outside diameter $\frac{1}{4}$ in., 2-in. arms, 4 T-tubes; EA 7100, $\frac{1}{4}$ in. at 38¢ . . . . .	1.42
A17	Glass nozzle-tube (draw 6-in. tube in flame) . . . . .	.06
A18	Glass pressure tube, length 24 in., outside diam. 18–20 mm., wall 2–2 $\frac{1}{2}$ mm. closed at one end; SS . . . . .	.40
A19	Glass tubing, outside diam. 7 mm. thickness of wall $1\frac{1}{4}$ – $1\frac{1}{2}$ mm. at 50¢ per lb., per ft. 3¢; A19a to A19d—SS or CS or LK.	
A19a	2 pieces 24 in. long at .06 . . . . .	.12
A19b	2 pieces 12 in. long at .03 . . . . .	.06
A19c	4 pieces 6 in. long at .01 $\frac{1}{2}$ . . . . .	.06
A19d	3 pieces 4 in. long at .01 . . . . .	.03
A20	Hydrometer jar, heavy glass with pour out; WT 2700, height 12 in., diam., outside, $2\frac{1}{2}$ in. . . . .	.60
A21	Laboratory balance; SS, B600 or CS or LK . . . . .	6.00
A22	Lamp Chimney, Macbeth Students Chimney #50; SS, or in lot of half gross at \$ 6.00, Macbeth Evans Glass Co., Pittsburgh, Pa. . . . .	.15
A23	Leather sheeting for pump valves (purchase scrap shoe uppers from any shoemaker).	
A24	Manometer tube, U-tube, 12-in. arms, outside diam. 10 mm., thickness of wall 2 mm.; SS . . . . .	2.50
A25	Half meter stick for manometer tube, inches and millimeters; SS, B70 . . . . .	.30



A26 Meter sticks, inches on one side and millimeters on other; EA 4298 or SS or LK or CS . . . . .	.50
A27 Metric weights, 1 g. to 500 g.; SS, B840 . . . . .	3.00
A28 Nitric acid, technical grade; EA or SS or any chemical dealer	.10
A29 Piston rods, solid brass, for pumps and hydraulic elevator, diam. $\frac{1}{4}$ in., length 12 in., with three $\frac{1}{8}$ in. holes, two at one end $1\frac{1}{4}$ in. apart and one at other end; SS, D330 . . . . .	.25
A30 Pocket Ammeter, Eveready Type, 0-35 amp.; SS or SR or CW	.80
A31 Pocket Ammeters and Voltmeters mounted in wood stand with binding posts at \$2.50; SS. These ammeters may be used on 110-volt alternating current for approximate amper- age. On alternating currents the meter registers 75%. To correct the reading divide by .75 . . . . .	2.50
A31a Ammeter—Eveready dashboard type, mounted, 0-center, 0 to 15 amperes; SS . . . . .	5.00
A32 Pocket voltmeter, Eveready Type 0-10 volt; SS or SR or CW	1.00
A33 Push-button, oak; SS, N620 . . . . .	.10
A34 Reading glass lens, $2\frac{1}{2}$ -in. diameter; SS K200 or SR . . . . .	1.15
A35 Ring stands, tripod type, height 36 in., rod diam. $\frac{3}{8}$ in.; EA 6542 at 75¢ (2) . . . . .	1.50
A36 Ring stand clamps, Bunsen's (without fastener); EA 2016, small, at 50¢ (4) . . . . .	2.00
A37 Ring stand clamp fastener; EA 2042 at 20¢ (4) . . . . .	.80
A38 Ring stand ring, 2 in. diam.; EA 6010, diam. 2 in. at 10¢ (2) .	.20
A39 Ring stand ring, 3 in. diam.; EA 6010, diam. 3 in. at 12¢ (3) .	.36
A40 Rubber stoppers, \$1.80 per lb.; EA or SS or CS.	
A40a # 0 one hole with hole $\frac{3}{8}$ in diam. . . . .	.02
A40b # 1 one hole with hole $\frac{3}{8}$ in diam. . . . .	.04
A40c # 2 one hole with hole $\frac{3}{8}$ in diam. . . . .	.04
A40d # 5 one hole with hole $\frac{3}{8}$ in diam. . . . .	.06
A40e # 6 two holes with hole $\frac{3}{8}$ in diam. . . . .	.10
A40f # 6 one hole . . . . .	.10
A40g # 6 two holes (one hole at center) . . . . .	.10
A40h # 7 three holes at 15¢ (2) . . . . .	.30
A40i # 7 two holes (one hole at center) . . . . .	.15
A40j # 7 two holes at 12¢ (2) . . . . .	.24
A40k #10 one hole . . . . .	.36
A41 Rubber tubing, heavy wall, black; EA 6054, SS 12700b, specify inside diameter $\frac{3}{8}$ in.	
A41a 2 pieces 12 in. at 20¢ . . . . .	.40
A41b 2 pieces 6 in. at 10¢ . . . . .	.20

A41c	3 pieces 4 in. . . . .	.20
A41d	6 pieces 2 in. . . . .	.20
A42	Rubber tubing for Bunsen burner attachments, 2 ft.; EA #6048 heavy wall, white or red, inside diam. $\frac{1}{4}$ in., thickness of wall $\frac{1}{8}$ in. at 12¢ per ft. . . . .	.24
A42a	Rubber tubing, special for measuring faucet water pressure, inside diam. $\frac{3}{8}$ in., test 75 to 100 lbs. per sq. in.; SS, per foot . . . . .	.20
A43	Thermometers, Centigrade; SS or EA or CS . . . . .	1.00
A44	Wire, copper, double cotton covered No. 24; SS, double cotton covered magnet wire at \$2.60 per one pound spool . . . . .	.05
A44a	Lamp cord insulated copper wire for 110 volt line; SS N 8000 lamp cord wire No. 18.	

### B. Material Used in One Experiment Only.

B45	The Clock — Tick Tack Clock; SS or LK or CS . . . . .	1.80
B46	Measuring Fluid Pressures — Mercury; SS . . . . .	.20
B47	Floating Bodies — Lead Sinkers, wt. 4 oz., diam. 1 in., SS or LK . . . . .	.13
B47a	Aluminum pan, quart size — Wearever # 168 Pudding Pan, Aluminum Cooking Utensil Co., N. Y. or SS . . . . .	.50
B48	Liquid Cell and Dry Cell.	
B48a	Base-block 5 in. $\times$ 5 in. $\times$ 2 in. with round hole for round tumbler battery jar, 5 $\frac{1}{2}$ in. high $\times$ 2 $\frac{1}{2}$ in. bottom diam.; SS . . . . .	.50
B48b	Battery Jar as described above; SS or L. Straus & Sons, 44 Warren St., N. Y. In dozen lots, per doz. \$2.45 . . . . .	.21
B48c	Ammonium chloride salt (sal ammoniac), technical grade; SS or EA in ten pound lots at 20¢ . . . . .	.20
B48d	Battery zinc rods (pencil); SS or SP 021234 . . . . .	.10
B49	Electromagnets and Permanent Magnets.	
B49a	Nails, 12 penny . . . . .	.10
B49b	Nails, $\frac{1}{4}$ lb, half inch flat head, any hardware store . . . . .	.10
B49c	Steel knitting needles; SR . . . . .	.10
B50	Electroplating.	
B50a	Copper sheet, 7 in. long $\times$ 1 $\frac{1}{2}$ in. wide; SS . . . . .	.10
B50b	Copper sulfate powder or granules technical, any chemical supply house in 10 pound lots at 25¢; Merck & Co., N. Y. . . . .	.10
B50c	110-volt lamp resistance board with keyless sockets; SS or CS . . . . .	1.50
B51	Electric Light and Power.	
	Small electric motor (Little Hustler), 3 volt; CS or LK or SS . . . . .	1.50
B52	Law of Reflection.	
	Mirrors, nickel plated (special); SS . . . . .	.25

B53 Law of Intensity.	
Cardboards with holes and with one inch squares for screen;	
SS . . . . .	.10
B54 Prism and Lens.	
B54a Prism, equilateral, width of face 28 mm., length 75 mm.;	
CS F6511 . . . . .	.60
B54b Protractor, brass; LK 13-90 . . . . .	.12
B55 Lens and Glass Cube.	
Glass Cube; LK 74-62, 50 mm. edge . . . . .	.80
B56 Absorption and Light.	
Gelatine Color Films, sheets 8×10 set of red, green, blue;	
SS J640, at 20¢ . . . . .	.60
B57 Tuning Fork and Vibrating Column.	
Tuning Fork, 512 vibrations per sec.; SS H150 . . . . .	1.50
B58 Vibrating String.	
Piano wire, diam. .025 in. (music gauge #10) (B&S #22)	
SS 15385; per meter . . . . .	.05
B59 Pressure Tank Water System Pump, brass hand pump; SS or	
A. B. Sands & Son, 20 Vesey St., N. Y. . . . .	2.50

## GROUP II-III EXPERIMENTS

37 Blood Pressure.	
37A U-tube (use manometer tube Group I.); SS . . . . .	2.50
37B Arm sleeve, rubber bag, and rubber bulb (pump); Taylor Instru-	
ment Companies, Rochester, N. Y. . . . .	5.00
38 Camera A.	
38A Premo #8 for plate holder or film pack adapter, with planato-	
graph lens, size 4×5; Eastman Kodak Co., Rochester, N. Y.	15.00
38B Pin-hole camera; LK, CS, SS, J860 . . . . .	.65
39 Electric Motor A.	
39A St. Louis Motor with electromagnet attachments; CS or SS. . . . .	4.00
39B 35-ampere battery ammeter (Eveready mounted); SS . . . . .	2.50
39C 2 dry cells — 40 cents each . . . . .	.80
40 Fireless Cooker.	
40A Duplex Fireless Cooker; CW or see SR . . . . .	11.25
40B Gas burner (stove); I. Block & Son, N. Y., #1 with star burner . . . . .	1.70
40C Thermos bottle; pint size, SS or CS . . . . .	1.75
40D Copper quart measure; CS #8394 . . . . .	1.60
40E Chemical thermometer, 0° to 212° F; SS or CS . . . . .	1.25
40F Aluminum saucepan, 4 quart; CW . . . . .	1.21
40G 200-c.c. glass graduate; SS 4705 or CS . . . . .	.65

**41 Gas Stove Burner.**

41A Gas burner; I. Block & Son, N. Y., #1 with star burner . . . . .	1.70
41B Gas meter — Large Dial Demonstration Dry Meter, 5 light; American Meter Co., N. Y. . . . .	18.00
41C Screw clamp, pinch cock, Hoffmans; SS medium . . . . .	.25
41D Alarm clock, without bell; SR . . . . .	1.00
41E Copper quart measure; CS #8394 . . . . .	1.60
41F Enamel-ware kettle, 4 quarts; SR . . . . .	.55
41G Chemical thermometer, 0° to 212° F; SS or CS . . . . .	1.25

**42 Gasoline Engine A.**

42A 1½ Horse power gasoline engine on truck. The feed pipe from tank may be disconnected and the engine operated by illumi- nating gas by means of rubber tube connection; SR . . . . .	52.10
42B Large glass battery jar, 6×8 in.; SS or CS . . . . .	.40
42C Induction Coil; SR, 6A9234 . . . . .	4.85
42D 4 dry cells; SP, 40¢ each . . . . .	1.60
42E Ignition bottle; SS or use tall narrow bottle 1½ in. diam. (olive bottle).	
42F Magneto generator with small lamp; CS, F3715 . . . . .	5.00

**45 House Gas Supply.**

45A Gas meter — Large Dial Demonstration Dry Meter; American Meter Co., N.Y. . . . .	18.00
45B Gas stove burner; I. Block & Son, N. Y., #1 with star burner . . . . .	1.70
45C Laboratory Bunsen burner; EA 1462 . . . . .	1.00
45D Gas iron (flatiron); SR or CW . . . . .	2.10
45E Open flame gas lamp; LK, 70-90 . . . . .	.80

**46 House Water Supply.**

46A Water Meter for half in. pipe connections; National Meter Co., 299 Broadway, N. Y. . . . .	16.50
46B Lever handle stop cock, ½ in. pipe; SR . . . . .	.70
46C 2-ft. piece flexible garden hose with ½-in. hose coupling; SR . . . . .	.70
46D Screw faucet; SR, Compression Hose Bibb ½-in. . . . .	.78
46E Compression faucet; SR, Fuller Pattern Plain Bibb, ½-in., ½-in. pipe, 2 six-in. pieces, 1 twelve-in. piece, 4 L's, SR, or from pipe fitter . . . . .	.70
46F Gallon measure, tinned iron; CS 8396 . . . . .	.40
46G Quart measure, tin; SR . . . . .	.38
46H Wrench, Auto type, length approximately 9-in; SR . . . . .	.46
46I Screw driver, 4-in. blade; SR . . . . .	.30

**47 Dew Point.**

47A Nickel plated beaker; SS 750 . . . . .	1.25
47B Chemical thermometer, 0° to 212° F; SS or CS . . . . .	1.25
47C Pan for ice; SR. . . . .	.15

**48 Jackscrew**

48A Jackscrew, 10-in. stand; SR or CW . . . . .	3.20
48B 50 lb. weight; SR, Atlas test weight (2), \$5.75 each . . . . .	11.50
48C Spring balance, 64 oz.; SS, B510 . . . . .	.50

For lever use a piece of iron pipe.

**49 Kerosene Stove.**

49A Stove, Single Burner Perfection Wick Stove; Cleveland Foundry Co., Cleveland, Ohio. Remove tin shield from inside of filler, plug opening to aid in pouring kerosene from the tank . . . . .	5.00
49B 200-c.c. graduate; SS, 4705 or CS . . . . .	.65
49C Tin or aluminum funnel and tin pan, 3 pints . . . . .	.20
49D Four-quart kettle, enamel ware; SR. . . . .	.55
49E Chemical thermometer, 0° to 212° F; SS or CS . . . . .	1.25
49F Copper quart measure; CS 8394 . . . . .	1.60

**50 Lever and Scales.**

50A Test weights used in jackscrew experiment.	
50B Crowbar, 16 lb., pinch-point; SR . . . . .	1.75
50C Spring balance, 30 lb.; SS B530 . . . . .	1.60
50D Beam balance used in Group I experiments.	
50E Steelyard, 100 lb.; CW . . . . .	1.75
50F Wooden Box; SS . . . . .	.75

**51 Microscope.**

51A Reading glass lens; SS K200, SR 2½-in. size . . . . .	1.15
51B Short focus double convex lens; Bausch & Lomb Optical Co., Rochester, N. Y., #144 Watchmakers' glass 1½-in. focus . . . . .	1.00
51C Microscope; SR 20 R3399 . . . . .	4.95

**52 Optical Disk.**

52A Optical Disk Apparatus; SS or CS or LK . . . . .	16.50
--	-------

**53 Pressure Cooker.**

53A Pressure Cooker, 10 qt. size, with pressure thermometer; SS. . . . .	20.00
53B Gas burner; I. Block & Son, N. Y., #1 with star burner . . . . .	1.70

**54 Phonograph A.**

54A Phonograph; SR, 20 R4500 Junior Silvertone . . . . .	11.90
54B Record . . . . .	.75
54C Tuning Fork, 512 vibrations; SS, #H150 . . . . .	1.50
54D Lens 2 in. diam.; SS or SR . . . . .	1.20
54E Screw driver from laboratory tool drawer.	

**55 Projection Lantern A.**

55A Projection Lantern, Nitrogen Lamp Type; Bausch & Lomb, Rochester, N. Y. Home Balopticon for both opaque pictures and lantern slides . . . . .	45.00
55B Screen; CS F7545, 6×6 feet . . . . .	7.00
55C Ammeter, battery (Eveready) mounted; SS . . . . .	2.50

**56 Pulley.**

56A Pair of Triple Tackle Blocks, one with becket; SR or CW . . . . .	3.43
56B Same weights as used in jackscrew.	
56C Same spring balance used in jackscrew.	

**57 Pump — Kitchen Lift Pump.**

57A Pitcher spout iron pump with 2½-in. brass lined cylinder; SR 42R5200¼, CW. Mount on a table using two buckets . . . . .	3.60
--	------

**58 Saucepan Conduction.**

58A Gas burner; I. Block & Son, N. Y., #1 with star burner . . . . .	1.70
58B Gas meter, Large Dial Demonstration Meter; American Meter Co., N. Y. . . . .	18.00
58C Screw clamp, pinchcock; Hoffmans, SS medium . . . . .	.25
58D Copper quart measure; CS #8394 . . . . .	1.60
58E Clock without bell; SR . . . . .	1.00
58F Four-quart saucepan, enamel ware; SR . . . . .	.55
58G Chemical thermometer, 0° to 200° F; SS or CS . . . . .	1.25
58H Saucepan, 4 quarts, aluminum; SR 9R2223, 4 quarts . . . . .	1.45
58I Saucepan, 4 quarts, copper; Bramhall Dean Co., 261 W. 36th St., N. Y. . . . .	3.50

**59 Sewing Machine A.**

59A Small hand Singer machine; Singer Sewing Machine Co., #20, at \$3.50. . . . .	3.50
--	------

**60 Water Motor A.**

60A Water Motor with Bourdon pressure gauge 0 to 100 lb.; SS . . . . .	12.00
60B Gallon measure, tinned iron; CS 8396 . . . . .	.40
60C Copper quart measure; CS 8394 . . . . .	1.60

**61 Alternating Currents.**

61A Coils used in Electric Generator.	
61B Pocket compass; SS N405 . . . . .	.25
61C Large Permanent Magnet SS. Get an old steel file, size 1 in. X 10 in. or SR.	
61D Telephone magneto generator; CS F3715 . . . . .	5.00
61E Battery voltmeter, Eveready type 0-10 volts mounted; SS . . . . .	2.50
61F Electric bell; SS or SR, size gong 2½ in. . . . .	.60
61G Dry cell — any electrical store . . . . .	.40

**63 Camera C.**

63A Negative, plate negative.	
63B Printing Frame, 4X5; SR 20R1410 . . . . .	.20
63C Aristo Gold Paper, 4X5; Eastman Kodak Co., Rochester, N. Y., per doz. sheets . . . . .	.20
63D Hypo, or Acid Fixing Powder; CW, per lb. . . . .	.25
63E Sal soda (sodium carbonate); SS, per lb. . . . .	.25
63F Glass graduate in oz., measuring glass 8 oz.; SR . . . . .	.15
63G Glass tray, 4X5; CW . . . . .	.15
63H White enamel trays (2); CW, at 55 cents, 4X5 in. . . . .	1.10

**64 Electrical Disk Stove.**

64A Electric stove or hot plate; SR 6P8027¼, 110 volts . . . . .	7.95
64B Chemical thermometer, 0°-212° F; SS or CS . . . . .	1.25
64C Copper quart measure; CS #8394 . . . . .	1.60
64D 4 qt. saucepan, enamel ware; SR . . . . .	.55
64E Gas burner, use burner for Saucepan experiment.	
64F Clock, use one of laboratory alarm clocks.	

**65 Electric Generator.**

65A Generator operated by hand power; LK 97-148, Dissectible Hand Power Dynamo and Motor . . . . .	40.00
65C Battery ammeter, Eveready type, 0-35 amperes mounted; SS . . . . .	2.50
65D Battery voltmeter, Eveready type, 0-10 volts, mounted; SS . . . . .	2.50
65E Small motor, Little Hustler; CS or LK or SS . . . . .	1.50
65F Telephone magneto generator, use same generator as in Alternating Currents experiment.	
65G Motor-generator — same as used in Electric Motor B, or use Large Evans Motor Generator; CS.	

**66 Electric Immersion Heater.**

- 66A Electric immersion heater; SR, Majestic, 6P8079, or SS N6020,  
600 watts . . . . . 4.35  
(This apparatus may be kept with the apparatus for Electric  
Disk Stove experiment.)

**67 Electric Motor B.**

- 67A 4 dry cells, any electrical dealer, each 40 cents . . . . . 1.60  
67B Battery ammeter, Eveready, mounted; SS . . . . . 2.50  
67C Generator-Motor, hand power; LK 97-150 Dissectible, use same  
apparatus as in Experiment 65, Electric Generator. Evans  
Motor-generator set, CS, E70, 110 volt, A. C. or D. C.  
Motor with two armatures for the generator.  
67D Rheostat — use rheostat suitable for the motor when attaching  
110-volt line; CS or SS.  
67E Compass; SS . . . . . .25

**68 Gasoline Engine B.**

Use the engine of Gasoline Engine A.

**69 Horse Power A.**

- 69A Universal Electric Motor for either AC or DC, 110 volts; SS  
N1384, mounted on ring stand for brake test . . . . . 10.00  
69B Right angle clamp; SS A1280, size (b) . . . . . .75  
69C Iron Rod 8 in. long, diameter 8mm.; SS . . . . . .15  
69D Spring balances (2) 64 oz., SS B510, each 50 cents . . . . . 1.00  
69E Speed counter; SS B150 . . . . . . 1.00

**70 Horse Power B**

Same apparatus used in Horse Power A.

- 70A Ammeter for DC current use; SS N1850, 15 ampere (Weston  
Meter # 167). This meter should be mounted on wood stand . . . . . 12.50

**72 Humidity B.**

- 72A Wet and dry bulb hygrometer; Taylor Instrument Co., Roches-  
ter, N. Y. . . . . . 2.50

**73 Phonograph B**

- 73A Same instrument used in Phonograph A.  
73B Screw driver; SR or CW. . . . . .15

**74 Projection Lantern B.**

- 74A Carbon arc projection lantern; Bausch & Lomb Opt. Co., Roches-  
ter, N. Y., #5000 . . . . . 45.00



74B Small carbon rods; Bausch & Lomb Opt. Co., 4473, per 10 . . .	.38
74C Large carbon rods; Bausch & Lomb Opt. Co., 4470, per 10 . . .	.40
74D Five-ampere rheostat, 110 volts; Bausch & Lomb Opt. Co., 4452 . . . . .	5.00
74E Ammeter same as used in Horse Power B.	
74F Single lamp board and one ampere lamp; SS . . . . .	2.00
74G 15-ampere rheostat; Bausch & Lomb Opt. Co., 4450 . . . . .	7.00

**75 The Rheostat.**

75A #30 Nickel chromium alloy; SS, Nichrome resistance wire, one pound spool, Hoskins Mfg. Co., Detroit, Mich., per pound	3.75
75B Rheostat used in Projection Lantern B.	
75C Ammeter, mounted battery type; SS . . . . .	2.50

**76 Sewing Machine B**

76A Buy a used machine or purchase one from SR or CW . . . . .	35.00
--	-------

**77 The Steam Engine.**

77A Small outfit engine and boiler; LK 69-85 . . . . .	.80
77B Large outfit engine and boiler; LK 69-120 . . . . .	74.50
77C Demonstration model; LK 69-30 . . . . .	3.25

**78 Telephone A.**

78A Telephone receivers (3); SR 6R8165, or SS, each \$1.40 . . . . .	4.20
78B Telephone transmitters (2); SR 6R8159, each \$1.90 . . . . .	3.80
78C Wire #18 annunciator; SR 6R9902, one pound . . . . .	.64
78D Binding posts with wood screw for ends of wires (4); SS N570, each 25 cents . . . . .	1.00
Extend wires from one room to another if convenient.	
78E Two dry cells, each 40 cents. Use No. 24 insulated wire for making attachments; SS.	
78F Clock without alarm; SR . . . . .	1.00
78G Copper plates (thin) two each one inch square. Punch small hole for wire; SS.	
78H Carbon granules. Break up old projection-lantern carbon and keep in a bottle.	

**79 Telephone B**

79A Short line battery telephone, 2 instruments; Manhattan Elec- trical Supply Co., N. Y., 1561, each \$5.00 . . . . .	10.00
The back should be removable from these phones to show the wiring.	
79B Magneto generator, three magnets; CS F3715 . . . . .	5.00

**80 Telescope**

80A Double convex lens in mount—reading glass, lens 3 in. diameter; SR . . . . .	2.65
80B Short focus, double convex lens; Bausch & Lomb Optical Co., Rochester, N. Y. #144. Watchmaker's glass 1½ in. focus . . . . .	1.00

**81 Thermometer.**

81A Thermometer or barometer tubing, diameter five mm., bore one mm.; SS, CS . . . . .	.50
---	-----

**82 Vacuum Cleaner**

82A Vacuum cleaner—centrifugal fan type . . . . .	40.00
82B Manometer tube; SS . . . . .	2.50
82C Rubber stopper, #7, one-hole; SS . . . . .	.15
82D Speed indicator same as used in Horse Power A.	
82E Rule, any foot rule.	
82F Ammeter, same as used in Horse Power B.	
82G Rug, one and one half feet by three feet . . . . .	3.00
82H Spring Balance, 30 lb.; SS B530 . . . . .	1.60
82I Screw driver; SR . . . . .	.15

**83 Water Heater.**

83A Gas meter. Use meter from House Gas Supply Exp. (41).	
83B Screw clamp, pinch cock, Hoffmans; SS, medium . . . . .	.25
83C Gas water heater; SR 42R1080½ or SS . . . . .	5.80

The water tube ends may be fitted with a reducer to three eighths and with brass hose ends for connecting with water faucet by means of rubber tubing. A brass hose end should also be connected to the gas inlet for convenience in attaching to gascock.

Get two galvanized reducers changing from three quarters to three eighths size . . . . .

.30

83D Brass hose ends—male (3); E. P. Gleason, 37 Murray St., N. Y., at .13 . . . . .	.39
83E Rubber tubing; EA 6048, heavy wall, white, inside diam. ¼ in., 10 feet at 12 cents . . . . .	1.20
83F Faucet stopper (rubber) . . . . .	.10
83G Gallon measure; CS 8396, 40¢, or SS, copper plated, 75¢ . . . . .	.40

**84 Water Motor B.**

84A Water motor. Use apparatus of Water Motor A.	
84B Two spring balances; SS B500, at 80¢ . . . . .	1.60
84C Speed counter same as used in Horse Power A.	

**85 Wireless A**

85A Two copper aerial wires, each 20 feet of #14 gauge; SR 6A9989 $\frac{1}{4}$	.40
85B Spark coil (induction coil); SR 6A9234 . . . . .	4.85
85C Five dry cells at .40 . . . . .	2.00
85D Wireless key; SR 6A9242 . . . . .	1.29
85E Aerial insulators (4); SR 6A9338, at 27 cents . . . . .	1.08
85F Detector stand; SR 6A9207 . . . . .	1.95
85G 1000-ohm receivers; SR 6A9440 (meteor) . . . . .	3.90

**86 Wireless B.**

Aerials same as Wireless A.

Induction coil same as Wireless A.

86A Sending transformer; SR 6A9244, Standard Helix . . . . .	2.75
86B Leyden jar for sending aerial; SR 6A9202 . . . . .	2.30
86C Use dry cells and key of Wireless A.	
86D Slide tuner; SR 6A9256, Acme Double Slide Tuner . . . . .	3.10
86E Fixed condenser; SR 6A9264, Standard Fixed Cond. . . . .	.60
86F Variable condenser; SR 6A9231 . . . . .	3.50
86G 1000-ohm receiver. Use apparatus of Wireless A.	
86H Receiving transformer; SR 6A9216, Precision Receiving Transformer . . . . .	7.75

**87 Carburetor A**

87A Bunsen burner. Use laboratory burner.

87B Ignition bottle. Use a heavy glass cylinder (olive bottle) or hydrometer jar 1 $\frac{1}{2}$  in. inside diameter; SS.

87C Large glass battery jar; SS or SC . . . . . .40

87D Sectional carburetor. Get second-hand carburetors from automobile dealers and have one or more of them cut open by a machinist, or purchase sectional carburetor from manufacturer 10.00

**88 Carburetor B.**

Same apparatus as for Carburetor A.

**89 Ford Engine A.**

89A Get second-hand Ford car. Remove body and radiator, cylinder head, bottom plate from crank case and one piston from crank shaft. Have a blacksmith extend an iron from the chassis frame to hold the steering apparatus in place . . . . 100.00

**90 Ford Engine B.**

Same as Ford Engine A.

**91 Ignition Systems A.**

91A Four dry cells at 40 cents . . . . .	1.60
91B 10 feet of flexible lamp cord wire; SS N8000 lamp cord wire No. 18 . . . . .	.65
91C Induction coil, use coil of Gas Engine A, Experiment 42.	
91D Automobile spark plugs. Champion; SR. . . . .	.70

**92 Ignition Systems B.**

92A Induction coil. Use apparatus in Ignition Systems A.	
92B Four spark plugs. Champion; SR . . . . .	2.80
92C Four ring stands. Use regular laboratory stands and clamps.	
92D Wooden block with four binding posts. Mount four binding posts on a block 4 inches square. Binding posts (4); SS N570, at 25 cents . . . . .	1.00
92E Make-and-break coil; SR 6R9509 . . . . .	.90

**93 Ignition Systems C — Ford Ignition.**

93A Ford engine and chassis.

The Ford induction coil box should be mounted on the chassis frame at the left of the engine.

93B 10 feet of flexible lamp cord wire; SS N8000 lamp cord wire No. 18 . . . . .	.65
93C 6 dry cells . . . . .	2.40

**94 Storage Battery A.**

94A Round battery jar $5\frac{1}{2}$ in. high by $2\frac{1}{2}$ in. bottom diameter in wooden base block; SS . . . . .	.60
94B Battery voltmeter, 10 volts (mounted); SS . . . . .	2.50
94C Battery ammeter, 35-ampere (mounted); SS . . . . .	2.50
94D Electric bell; SS . . . . .	.60
94E 2-volt lamp. Use with lamp socket; SS . . . . .	.20
94F Small motor, "Little Hustler," CS; SS N1362 . . . . .	1.50
94G Lamp board with one ampere, 110-volt lamp; SS N1475 with keyless socket . . . . .	1.00

**95 Storage Battery B.**

95A Lead storage cell in glass jar; CS 1042 No. B . . . . .	4.40
95B Battery hydrometer. Floating hydrometer for open type batteries; Willard Storage Battery Co., Cleveland, O. . . . .	.75
95C Battery ammeter, mounted; SS . . . . .	2.50

**Cabinets for Apparatus**

Cabinet of drawers for storing Group I Materials. For convenience these cabinets should not be higher than five feet;

Leonard Peterson & Co., Chicago. Get a quotation on upper half of Seed Cabinet, No. 1365.  
Cabinets for Group II Materials; Kewaunee Mfg. Co., Kewaunee, Wis., Nos. 1429, 1430, Leonard Peterson & Co., Chicago, Nos. 1386, 1387, 1388.

Valuable pieces of apparatus are stored in a special locker in the instructor's office. Students are required to sign a slip of paper with the name of the apparatus desired and the date. This slip is kept by the instructor and delivered to the student as a receipt for the apparatus when it is returned.

A centrally located drawer is assigned for general tools such as screw drivers, hammers, wrenches, files, etc.

#### **Electric Wiring for the Laboratory.**

Provision for electrical experiments with 110 volts current is made by extending a conduit along a table at the side of the room. This conduit should have outlets for attachment plugs three feet apart. For a class of twenty students ten outlets should be provided. The laboratory conduit should not be attached permanently to the supply lines. It should be connected by means of a knife-switch placed in a distribution box.

The first part of the book is devoted to a general history of the United States from its discovery by Columbus in 1492 to the present time. It covers the early years of settlement, the struggle for independence, the formation of the Constitution, and the growth of the nation to its present position. The author discusses the various factors that have shaped the country, including geography, climate, and the influence of different groups of immigrants.

The second part of the book is a detailed account of the American Revolution. It begins with the first steps towards independence, such as the Declaration of Independence in 1776, and continues through the major battles and the final victory at Yorktown in 1781. The author also discusses the impact of the Revolution on the young nation and the challenges it faced in the years following the war.

The third part of the book deals with the early years of the United States, from the end of the Revolution to the beginning of the 19th century. It covers the period of the Articles of Confederation and the early years of the Constitution. The author discusses the growth of the nation, the expansion of territory, and the development of a strong federal government.

The fourth part of the book is a history of the United States from the beginning of the 19th century to the present time. It covers the period of the Jacksonian era, the Civil War, the Reconstruction period, and the rise of the industrial revolution. The author discusses the major events and figures of this period, as well as the challenges and achievements of the nation.



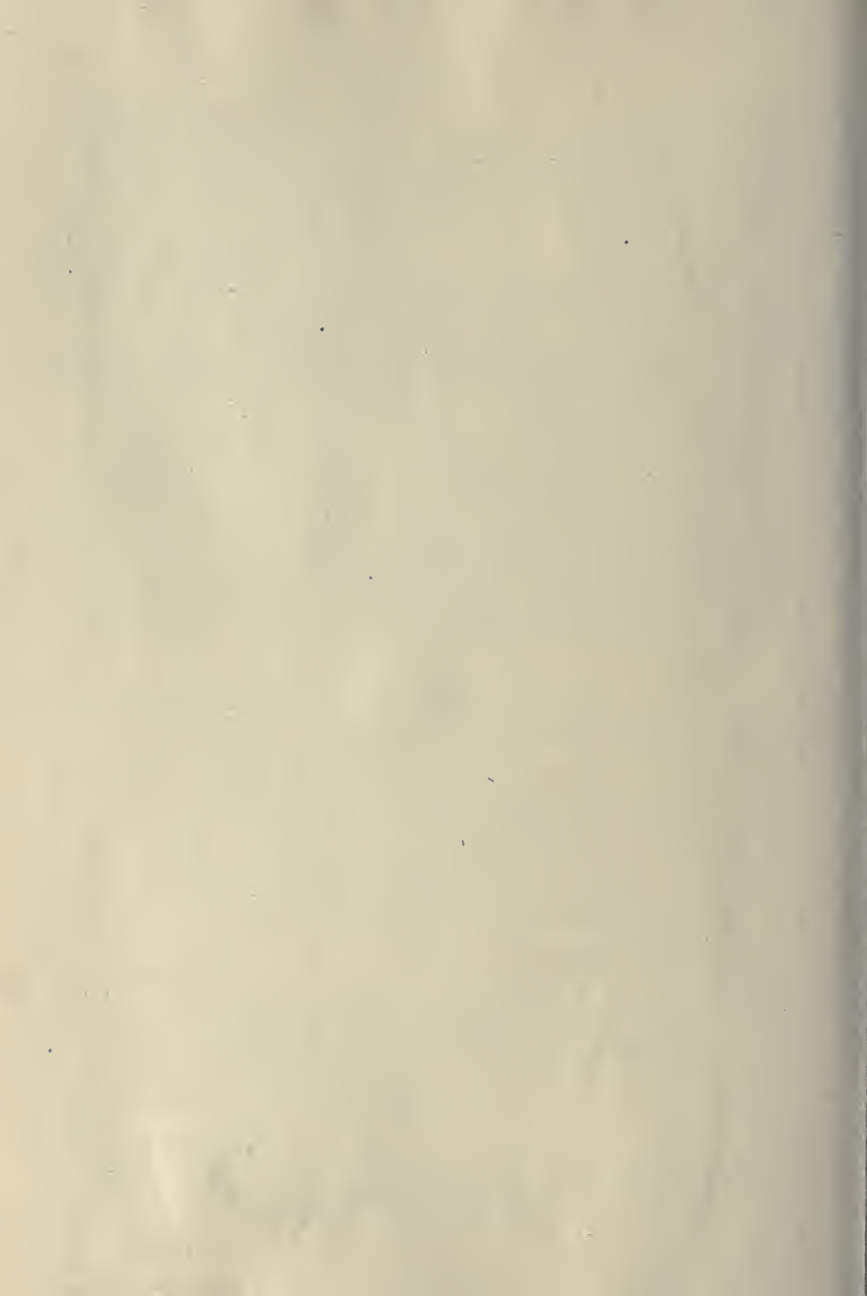





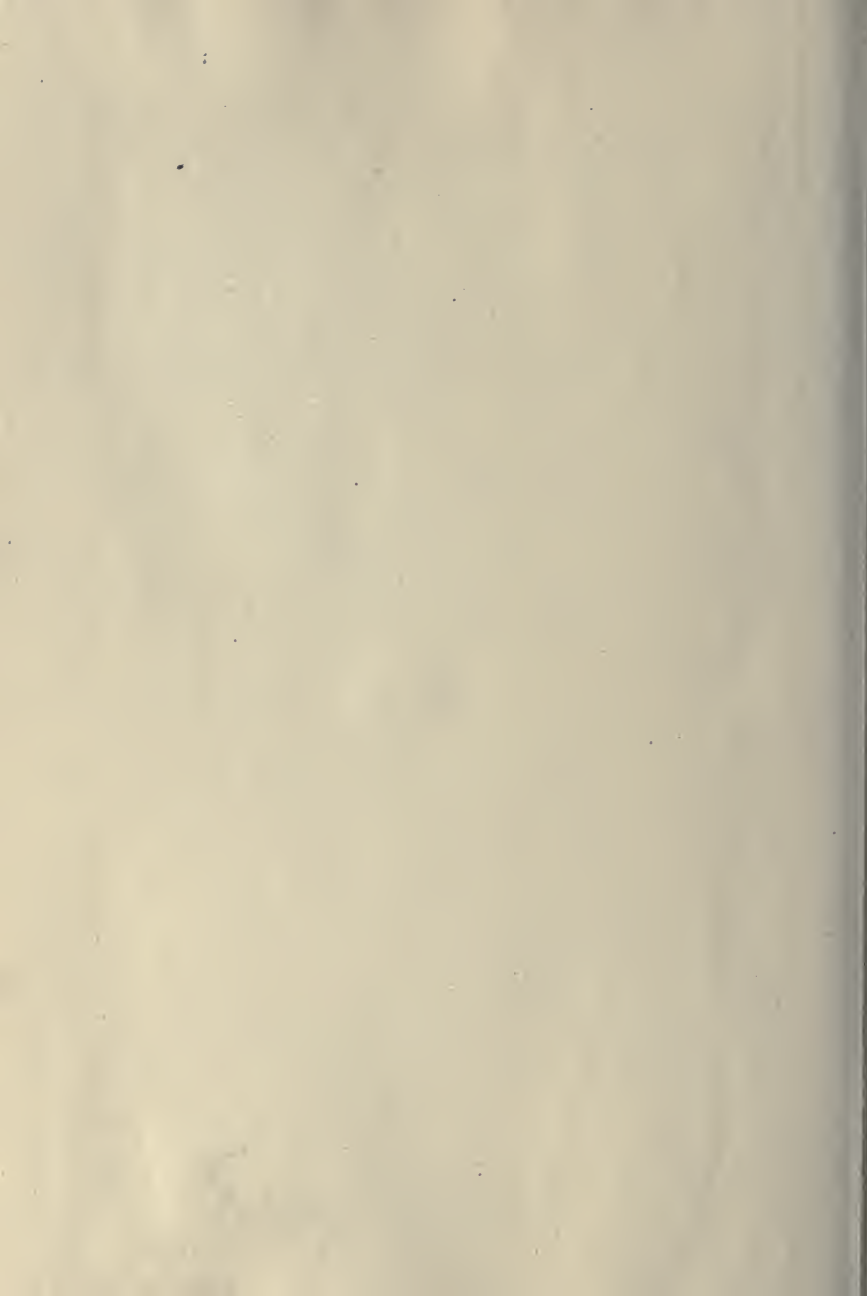

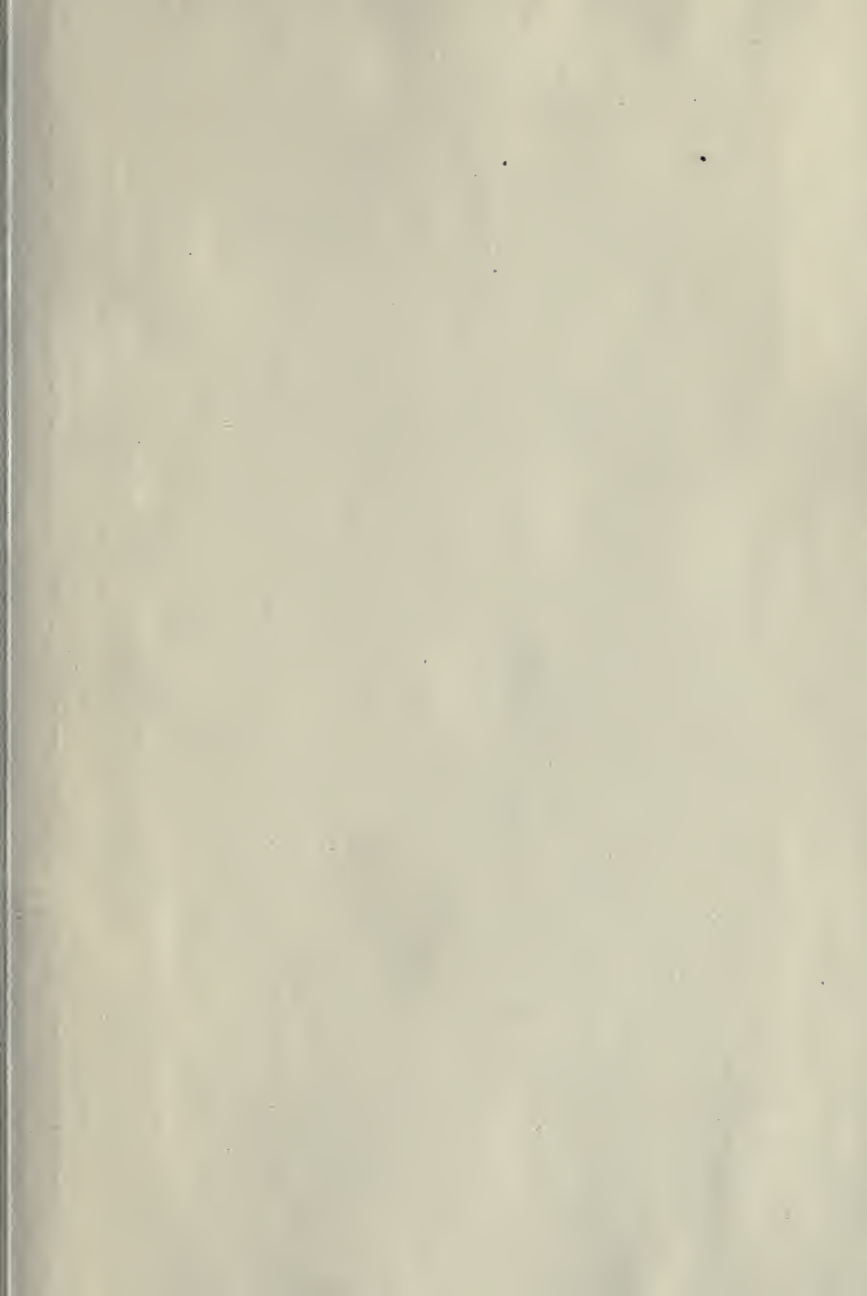

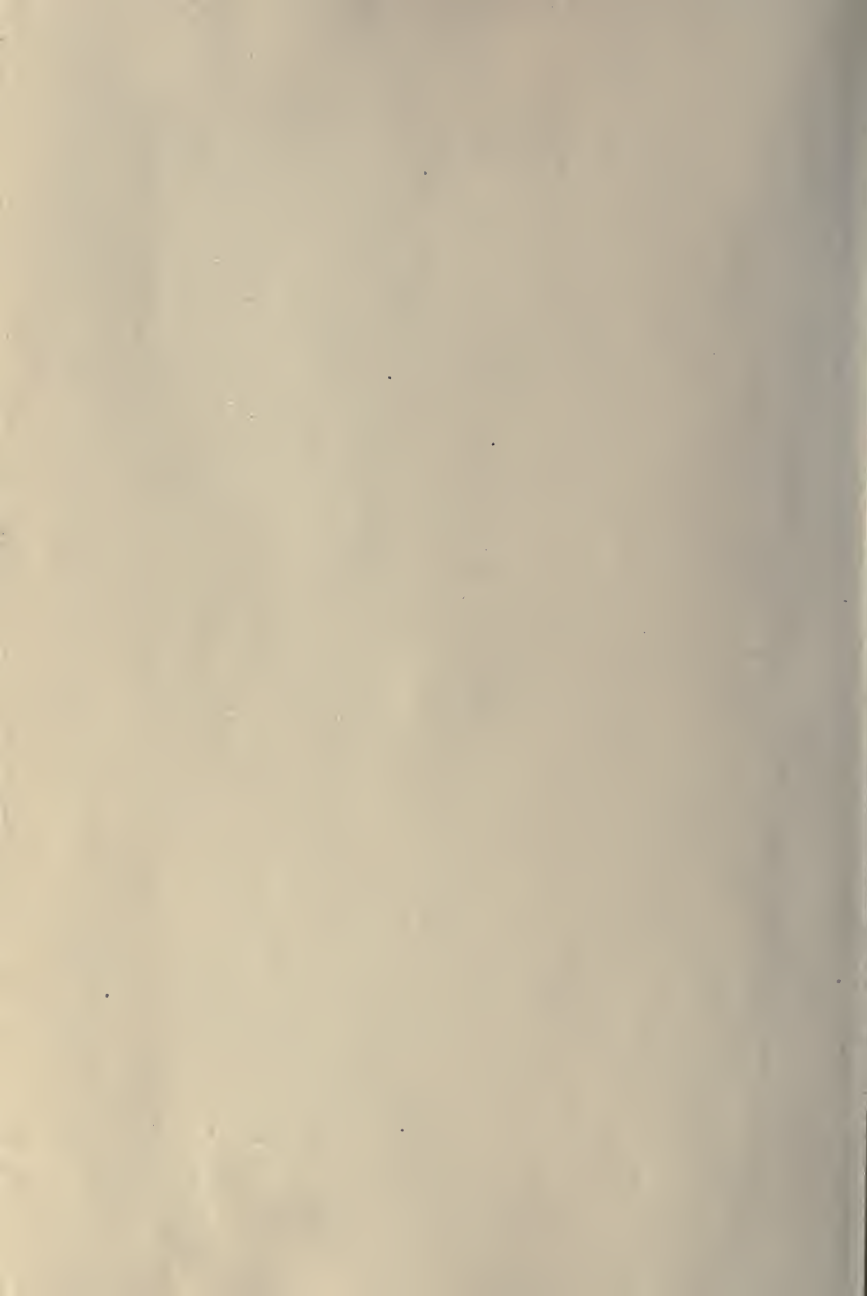

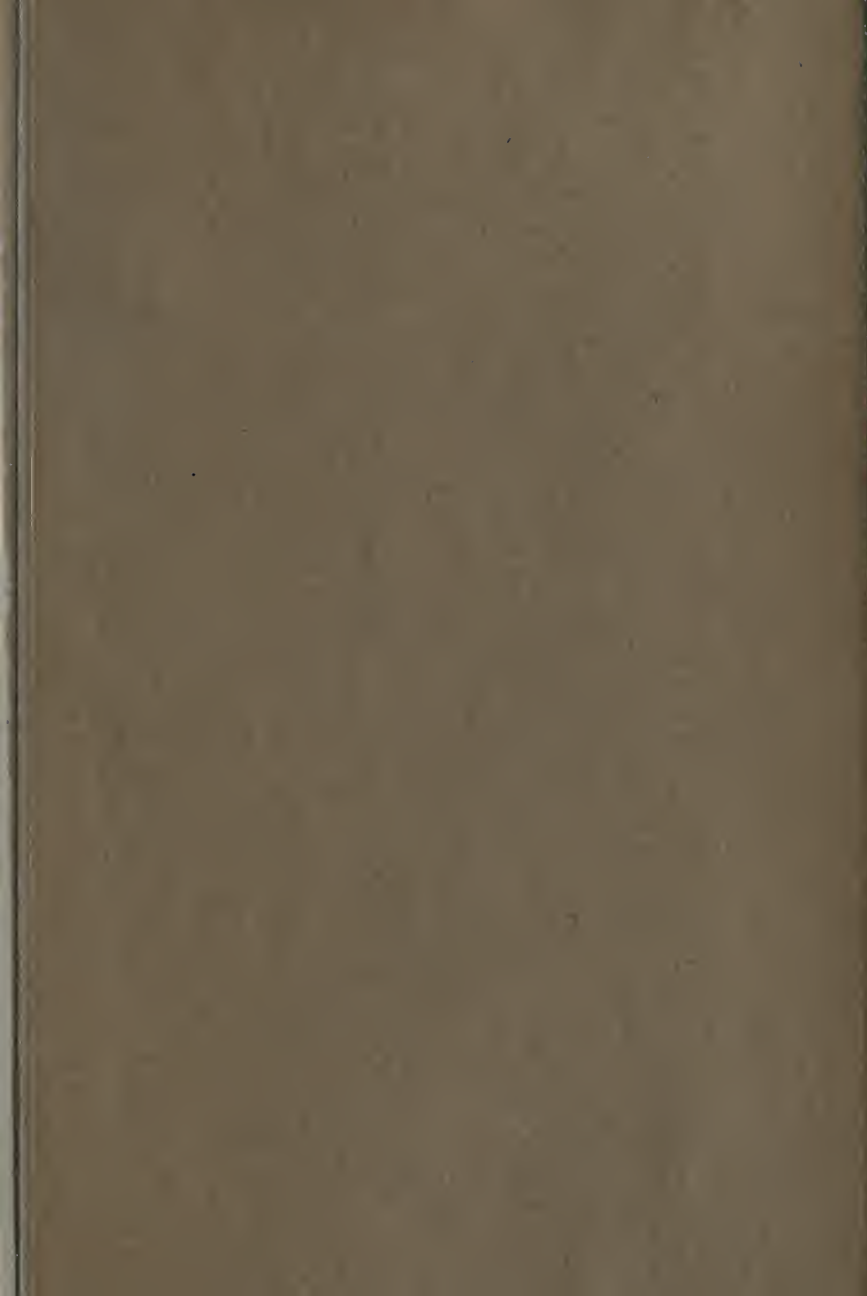



174257

Physics  
G.

Author ..... Good, Frederick Foreman

Title ..... Laboratory projects in physics.

DATE.

Nov 4 / 22

NAME OF BORROWER.

Satterley

University of Toronto  
Library

DO NOT  
REMOVE  
THE  
CARD  
FROM  
THIS  
POCKET

Acme Library Card Pocket  
Under Pat. "Ref. Index File"  
Made by LIBRARY BUREAU

